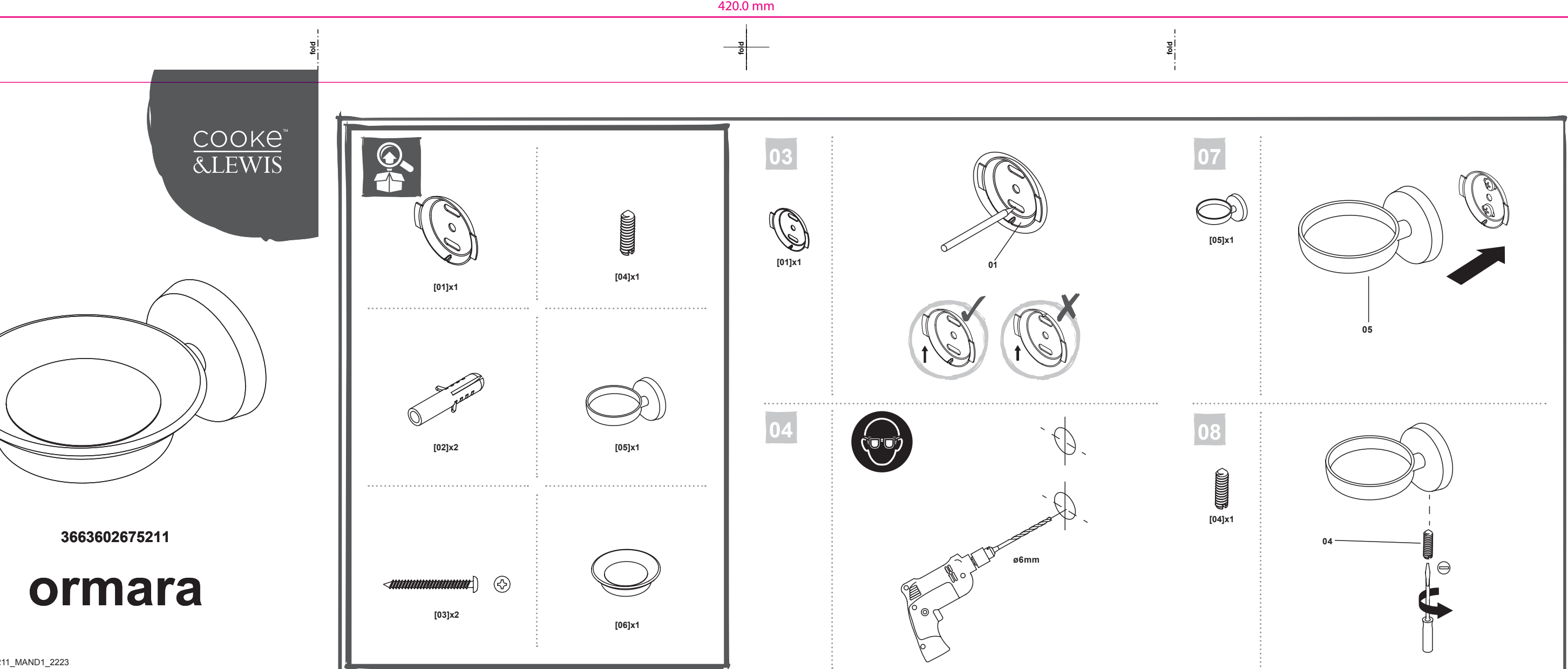
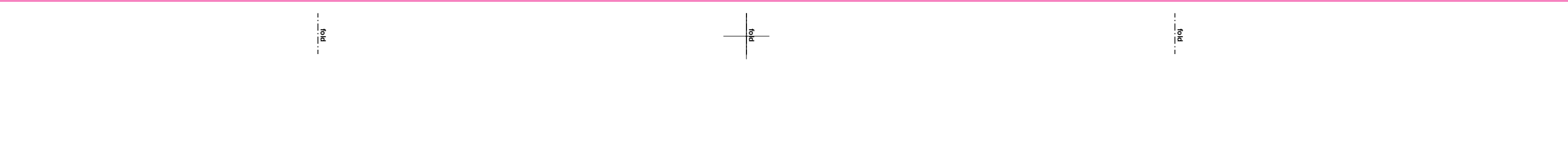
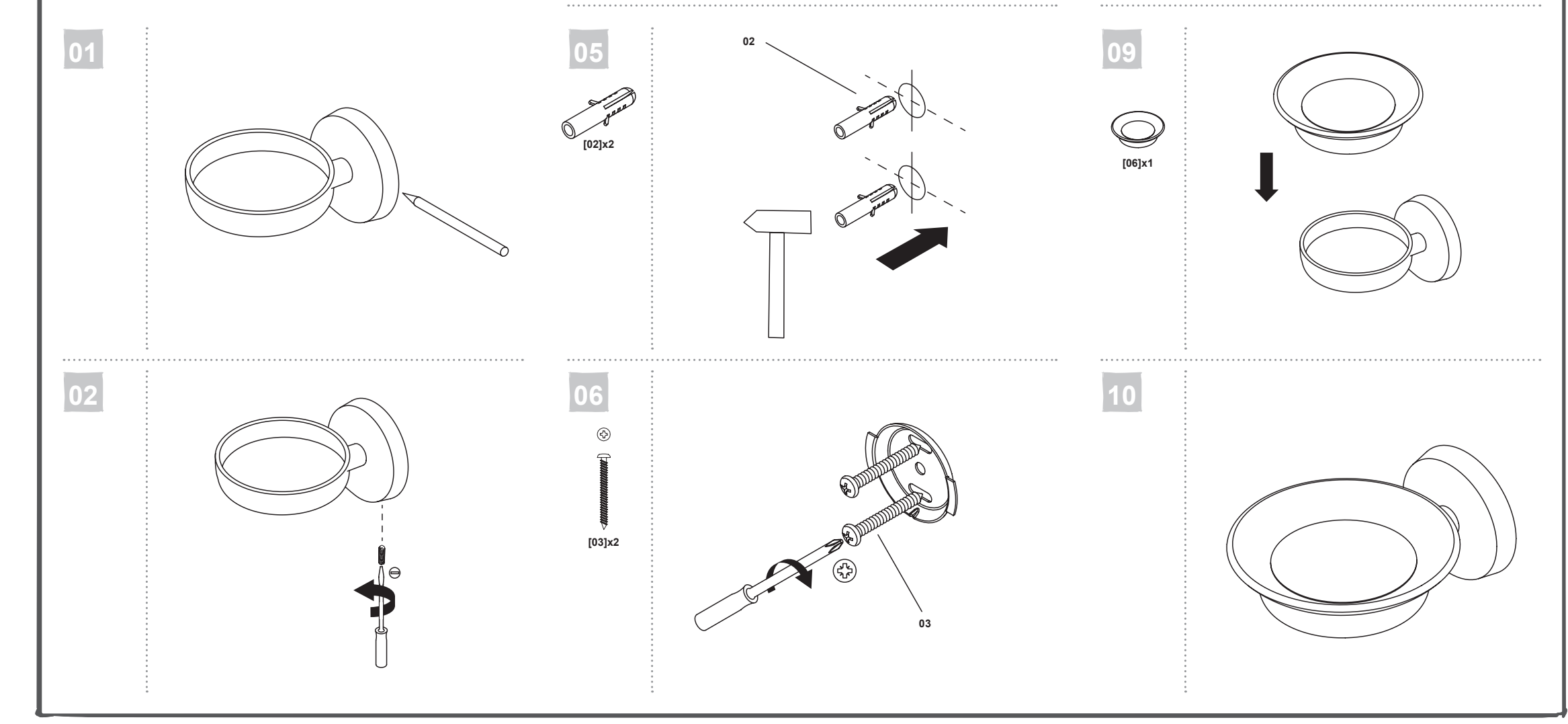

Table with 3 columns: SEPARATIONS, JOB INFO, VERSION #. Contains product details like Agency job #, Product Description, Brand, and Version information.



Important safety and installation instructions in multiple languages (EN, FR, PL, DE, etc.), including a 'Safety' section with icons and a 'Warranty Period and Conditions' section.



Multi-language instruction manual for 'ormara' in EN, FR, PL, DE, RU, RO, ES, PT, and TR. Each section includes 'Getting started...', 'Safety', 'Warranty Period and Conditions', and 'Disposal' information.

Table with 3 columns: SEPARATIONS, JOB INFO, VERSION #. Contains product details like Agency job #, Product Description, Brand, and Version information.

Multi-language instruction manual for 'ormara' in EN, FR, PL, DE, RU, RO, ES, PT, and TR. Each section includes 'Getting started...', 'Safety', 'Warranty Period and Conditions', and 'Disposal' information.