



EAN: 3663602713500 / 5059340844350

EN 34 mm Timber Shed with a 10 m²
Double Pent Roof

PL Domek narzędziowy drewniany 34 mm
z dachem dwuspadowym 10 m²

FR Abri de jardin en bois ép. 34 mm avec toit
à 2 pentes de 10 m²

RO Căsuță de grădină din lemn de 34 mm
cu acoperiș în două ape de 10 m²

Safety

- ✓ Take care when handling tools used for building the shed.
- ✓ Keep children and animals away from the assembly site.
- ✓ Some parts of the shed have sharp edges and can cause damage. Be sure to wear personal protective equipment: work gloves, long sleeves and goggles.
- ✓ Wear safety goggles for eye protection when using machine tools. Make sure power tools are well sealed to avoid any risk of electric shock.
- ✓ When using a ladder, make sure it is stable on the ground. Never put all your weight on the roof or any other part of the shed.
- ✓ Do not try to assemble the shed in high winds, as the work site may become hazardous.
- ✓ Be careful when working on the roof, and use appropriate safety equipment.
- ✓ Make sure you do not put anything onto shed parts so they maintain their original condition.
- ✓ Fuels and corrosive agents must be stored in sealed containers.
- ✓ Protect the shed from strong winds by fixing it properly to the foundation.

Foundations

- ✓ Check local planning regulations before installing your shed.
- ✓ Choose a suitable location and allow enough working space around the shed.
- ✓ Make sure you have a good base foundation before beginning shed assembly.
- ✓ The shed must be built on a solid, flat foundation. For a suitable base, we recommend that you use reinforced concrete or large concrete slabs.
- ✓ For a reinforced concrete foundation, prepare an initial layer of stones/pebbles. The foundation must be at least 10 cm thick. Leave your cement to dry for at least 48 hours.
- ✓ Make sure that the foundation is levelled and allows water drainage to avoid freezing.
- ✓ If the ground is at risk of freezing, the foundations must be below the frost line; otherwise, you need to install an insulation slab to stop frost from affecting the structure.
- ✓ Check each shed dimension to make sure it sits perfectly on the foundation.
- ✓ In order to avoid moisture rising through the walls, please always isolate the first plank from the slab using a level band (not supplied with garden shelters).
- ✓ Carefully laid foundations are crucial to successful construction. Foundations must be perfectly level. The foundations and structure must remain horizontal. Even after construction, the wooden structure must be able to expand and contract naturally.
- ✓ **WARNING:** If the shed is not constructed in one go, we advise you to store it inside or in a protected location. If this is the case, do not unpack the product. It must not be laid directly on the ground to prevent any contact with moisture. It is important that the storage location is flat, or your wooden baulks may buckle.

Warranty Period and Conditions

Special attention is paid when selecting high-quality materials, and use manufacturing techniques that enable us to create and design durable product ranges.

That is why we offer a 5 year warranty (excluding roofing materials), 1 year for all hardware and 2 years for joinery against product manufacturing defects.

This product is under warranty for 5 years as from the date of purchase, for normal, non-professional household use. The warranty shall only apply upon presentation of the till receipt or the invoice. Keep your proof of purchase in a safe place.

The warranty covers product breakdowns and malfunctions under the condition that the product is used in accordance with its intended use and subject to installation and maintenance in accordance with good practice and the information contained in the user's manual.

This product must be installed so that it may be later removed without damaging it.

This contractual warranty does not cover defects and damage caused by the natural wear of parts, bad weather, flooding, heat releases, freezing, damage caused by water quality (hardness, aggressiveness, corrosion, etc.), by the presence of foreign bodies transported by water or otherwise (sand, filings, etc.) or the lack of room ventilation, and damages that could be the consequence of improper use, misuse, negligence, accident or maintenance that is defective or does not comply with good practice or the information in the user's manual.

The following are also excluded from the warranty: harmful consequences due to the use of accessories and / or non-original equipment manufacturer or improper replacement parts, disassembly or product modification.

The warranty is limited to those parts recognised as defective. Under no circumstances shall it cover fringe expenses (travel, labour) and direct and consequential damage. Guarantee related queries should be addressed to a store affiliated with the distributor you purchased the product from.

This guarantee is in addition to and does not affect your statutory rights.

Manufacturer:

UK Manufacturer:

Kingfisher International Products Limited,
1 Paddington Square, London, W2 1GG,
United Kingdom

EU Manufacturer:

Kingfisher International Products B.V.,
Rapenburgerstraat 175E,
1011 VM Amsterdam,
The Netherlands

EN www.diy.com / www.screwfix.com / www.screwfix.ie

To view instruction manuals online,
visit www.kingfisher.com/products

IMPORTANT, RETAIN FOR FUTURE REFERENCE: READ CAREFULLY.

Sécurité

- ☑ Soyez prudent avec les outils utilisés pour le montage de l'abri.
- ☑ Eloignez vos enfants et vos animaux du site d'assemblage.
- ☑ Quelques éléments de l'abri contiennent des bords tranchants et peuvent causer des dommages. Veillez à porter l'équipement nécessaire à votre sécurité : des gants de travail, de longues manches et des lunettes de protection.
- ☑ Portez des lunettes de protection lors de l'usage de machines-outils. Assurez-vous de la bonne étanchéité de vos outils électriques pour éviter tout risque d'électrocution.
- ☑ Lorsque l'usage d'une échelle est nécessaire, assurez-vous de sa bonne stabilité au sol. Ne jamais s'appuyer de tout son poids sur le toit ou toute autre partie de l'abri.
- ☑ N'essayez pas d'assembler l'abri par plein vent au risque de rendre le chantier difficile et dangereux.
- ☑ Soyez prudent lorsque vous travaillez sur le toit et utilisez l'équipement antichute de sécurité approprié.
- ☑ Veillez à ne rien poser sur les pièces détachées de l'abri pour maintenir leur état d'origine.
- ☑ Les combustibles et le corrosif doivent être stockés dans des récipients étanches.
- ☑ Protégez l'abri des vents violents en le fixant bien aux fondations. Fixer le toit de l'abri avec soin.
- ☑ A monter soi-même.

Fondations

- ☑ Vérifiez vos codes d'urbanisme avant toute pose de votre abri.
- ☑ Choisissez un emplacement adapté pour pouvoir travailler autour de l'abri.
- ☑ Assurez-vous d'avoir de bonnes fondations avant de commencer l'assemblage de l'abri.
- ☑ L'abri doit être construit sur une fondation solide, et plane. Pour une base appropriée du plancher, nous vous recommandons d'utiliser une fondation en béton armé ou des dalles de béton de grande taille.
- ☑ Pour une fondation en béton armé, préparez une première couche de pierres / cailloux. La fondation doit faire à minima 10 cm d'épaisseur. Laissez sécher votre ciment pendant au moins 48 heures.
- ☑ Assurez-vous que la fondation soit nivelée, et qu'elle permette le drainage des eaux afin d'éviter le gel. Si le sol risque de geler, les fondations doivent se trouver au-dessous du niveau du gel, sinon il faut réaliser une base d'isolation pour empêcher le gel d'atteindre la structure.
- ☑ Vérifiez chacune des dimensions de l'abri pour vous assurer un parfait dimensionnement de la fondation.
- ☑ Afin d'éviter les remontées d'humidité dans vos murs, veillez à toujours isoler le premier madrier sur votre dalle à l'aide d'une bande d'arase (non livré avec l'abri de jardin).
- ☑ Des fondations effectuées avec soin sont un facteur déterminant pour un montage réussi. Les fondations doivent être parfaitement à niveau. Les fondations et la structure doivent rester horizontales. Même après le montage, la construction doit pouvoir travailler pleinement.

- ☑ ATTENTION: Si l'abri n'est pas monté rapidement, nous vous conseillons de le stocker à l'intérieur ou dans un endroit protégé. Dans ce cas, ne déballez pas le produit. Celui-ci ne doit pas être posé directement sur le sol afin d'éviter tout contact avec l'humidité. Il est important que l'endroit de stockage soit plat, au risque de déformer vos madriers

Durée et conditions de garantie

Nous accordons une attention particulière à la sélection de matériaux de haute qualité et à l'utilisation de techniques de fabrication qui nous permettent de créer et de concevoir des gammes de produits durables.

C'est la raison pour laquelle nous offrons une garantie 5 ans (hors matériaux de toiture), 1 an pour toute la quincaillerie et 2 ans pour la menuiserie contre les défauts de fabrication de nos produits.

Ce produit est sous garantie pendant une période de 5 ans à compter de la date d'achat, pour un usage normal, domestique et non professionnel. La garantie ne peut s'appliquer que sur présentation du ticket de caisse ou de la facture d'achat. Conservez votre preuve d'achat dans un endroit sûr.

La garantie couvre les pannes et dysfonctionnements du produit sous réserve d'une utilisation conforme à la destination du produit et sous réserve d'une installation et d'un entretien conformes aux règles de l'art et aux informations du manuel d'utilisation.

Ce produit devra avoir été installé de telle sorte qu'il puisse être retiré ultérieurement sans détérioration.

Cette garantie contractuelle ne couvre pas les défauts et détériorations provoqués par l'usure naturelle des pièces, les intempéries, les inondations, les dégagements de chaleur, le gel, les dommages causés par la qualité de l'eau (calcaire, agressivité, corrosion, ...), par la présence de corps étrangers véhiculés ou non par l'eau (sable, limailles, ...) ou le manque d'aération de la pièce et les dommages qui pourraient être la conséquence d'un usage inapproprié, d'une utilisation abusive, d'une négligence, d'un accident ou d'un entretien defectueux ou non conforme aux règles de l'art ou aux informations du manuel d'utilisation.

Sont également exclues de la garantie les conséquences néfastes dues à l'emploi d'accessoires et/ou de pièces de rechange non d'origine, ou non adaptées, au démontage ou à la modification du produit.

La garantie est limitée aux pièces reconnues défectueuses. Elle ne couvre, en aucun cas, les frais annexes (déplacement, main d'oeuvre) et les dommages directs et indirects.

Le bien est conforme au contrat :

- 1° S'il est propre à l'usage habituellement attendu d'un bien semblable et, le cas échéant :
 - s'il correspond à la description donnée par le vendeur et possède les qualités que celui-ci a présentées à l'acheteur sous forme d'échantillon ou de modèle ;
 - s'il présente les qualités qu'un acheteur peut légitimement attendre eu égard aux déclarations publiques faites par le vendeur, par le producteur ou par son représentant, notamment dans la publicité ou l'étiquetage ;

2° Ou s'il présente les caractéristiques définies d'un commun accord par les parties ou est propre à tout usage spécial recherché par l'acheteur, porté à la connaissance du vendeur et que ce dernier a accepté.

Article L217-12 du code de la consommation :

L'action résultant du défaut de conformité se prescrit par deux ans à compter de la délivrance du bien.

Article L217-16 du code de la consommation :

Cette période court à compter de la demande d'intervention de l'acheteur ou de la mise à disposition pour réparation du bien en cause, si cette mise à disposition est postérieure à la demande d'intervention.

Article 1641 du code civil :

Le vendeur est tenu de la garantie à raison des défauts cachés de la chose vendue qui la rendent impropre à l'usage auquel on la destine, ou qui diminuent tellement cet usage que l'acheteur ne l'aurait pas acquise, ou n'en aurait donné qu'un moindre prix, s'il les avait connus.

Fabricant :

EU Manufacturer:

Kingfisher International Products B.V.,
Rapenburgerstraat 175E,
1011 VM Amsterdam,
The Netherlands

FR www.castorama.fr / www.bricodepot.fr / www.screwfix.fr

Pour consulter les manuels d'instructions en ligne, rendez-vous sur le site

www.kingfisher.com/products



IMPORTANT - A CONSERVER POUR CONSULTATION ULTERIEURE : A LIRE ATTENTIVEMENT.

Bezpieczeństwo

- ☑ Zachować ostrożność podczas korzystania z narzędzi używanych do budowy domku ogrodowego. Nie dopuszczać dzieci i zwierząt do strefy montażu.
- ☑ Niektóre części domku ogrodowego mają ostre krawędzie i mogą spowodować uszkodzenia. Podczas pracy należy nosić środki ochrony indywidualnej: rękawice ochronne, odzież z długim rękawem i okulary ochronne.
- ☑ Podczas korzystania z narzędzi maszynowych należy nosić okulary ochronne, aby chronić wzrok. Upewnij się, że narzędzia elektryczne są odpowiednio uszczelnione w celu uniknięcia porażenia prądem.
- ☑ W przypadku korzystania z drabiny należy upewnić się, że stoi ona na stabilnym podłożu. Nigdy nie opierać się o dach ani inną część domku.
- ☑ Nie próbować montować domku ogrodowego podczas silnego wiatru, ponieważ miejsce pracy może stać się niebezpieczne.
- ☑ Zachować szczególną ostrożność podczas pracy na dachu i użyć odpowiedniego sprzętu zabezpieczającego.
- ☑ Nie kłaść żadnych przedmiotów na elementach domku ogrodowego, aby zachować ich oryginalny stan.
- ☑ Paliwa i środki powodujące korozję należy przechowywać w uszczelnionych zbiornikach.
- ☑ Należy zapewnić domkowi ogrodowemu ochronę przed silnym wiatrem, odpowiednio mocując go do fundamentów.

Fundamenty

- ☑ Przed rozpoczęciem montażu domku ogrodowego należy zapoznać się z lokalnymi przepisami dotyczącymi zagospodarowania i planowania.
- ☑ Wybrać odpowiednie miejsce, w którym można pracować wokół domku ogrodowego.
- ☑ Przed rozpoczęciem montażu domku ogrodowego należy upewnić się, że zapewniono odpowiednie fundamenty.
- ☑ Domek ogrodowy należy postawić na solidnej, płaskiej powierzchni. Aby zapewnić odpowiednie fundamenty, zalecamy skorzystanie ze zbrojonego betonu lub dużych płyt.
- ☑ W przypadku fundamentów ze zbrojonego betonu przygotować podłoże poprzez przykrycie go warstwą kamieni/kamyczków. Grubość fundamentów musi wynosić co najmniej 10 cm. Odczekać 48 godzin, aż do momentu wyschnięcia betonu.

- ☑ Upewnij się, że fundamenty są wypoziomowane i umożliwiają odpływ wody, aby uniknąć jej zamarzania.
- ☑ Jeśli podłoże jest narażone na zamarzanie, fundamenty muszą znajdować się poniżej granicy zamarzania; w przeciwnym razie konieczne jest zamontowanie płyty izolacyjnej, aby mróz nie wywierał negatywnego wpływu na konstrukcję.
- ☑ Sprawdzić każdy wymiar domku ogrodowego, aby upewnić się, że pasuje on do fundamentów.
- ☑ Aby zapobiec przedostawaniu się wilgoci do ścian, należy odizolować pierwszą deskę od płyty betonowej za pomocą taśmy fundamentowej (brak w zestawie).
- ☑ Dokładne położenie fundamentów jest kluczem do pomyślnego montażu. Fundamenty muszą być idealnie poziome. Fundamenty i konstrukcja muszą pozostać poziome. Nawet po zakończeniu budowy konstrukcja drewniana musi mieć możliwość naturalnego rozciągania się i kurczenia.
- ☑ **OSTRZEŻENIE:** Jeśli domek nie zostanie złożony w jednym podejściu, zalecamy przechowywanie go w pomieszczeniu lub w odpowiednio zabezpieczonym miejscu. W takim przypadku nie rozpakowywać produktu. Produktu nie należy kłaść na ziemi, aby uniknąć kontaktu z wilgocią. Niezwykle ważne jest, aby miejsce przechowywania było płaskie, ponieważ drewniane belki mogą ulec odkształceniu

Długość i warunki gwarancji

Przywiązujemy szczególną uwagę do selekcji materiałów wysokiej jakości oraz stosujemy techniki produkcyjne, które pozwalają nam na tworzenie i projektowanie trwałych rozwiązań.

Dlatego też oferujemy 5 lat (z wyłączeniem materiałów dachowych), 1 rok na wszystkie elementy montażowe i 2 lata na stolarkę obejmującą wady produkcyjne produktu.

Niniejszy produkt jest objęty 5-letnią gwarancją od daty zakupu w przypadku normalnego, nieprofesjonalnego użytkowania domowego. Gwarancja będzie rozpatrywana wyłącznie po przedstawieniu paragonu lub faktury. Dowód zakupu należy przechowywać w bezpiecznym miejscu.

Gwarancja obejmuje awarie i usterki, pod warunkiem że produkt jest używany zgodnie z jego przeznaczeniem oraz został zamontowany i konserwowany w prawidłowy sposób — zgodnie z informacjami zawartymi w instrukcji obsługi.

Produkt powinien być zamontowany w taki sposób, aby można go było w przyszłości zdemontować, nie powodując przy tym jego uszkodzenia.

Niniejszą gwarancją nie są objęte wady i uszkodzenia powstałe wskutek normalnego zużycia części, złych warunków atmosferycznych, zalania, wydzielania ciepła, działania niskich temperatur, złej jakości wody (twardość, agresywność, korozja itp.), obecności ciał obcych przenoszonych przez wodę (piasek, opiłki itp.) lub braku wentylacji pomieszczenia, a także z powodu niewłaściwego użycia, nadużycia, zaniedbania, wypadku lub konserwacji przeprowadzonej w nieodpowiedni sposób lub bez przestrzegania zaleceń zawartych w instrukcji obsługi.

Dodatkowo gwarancją nie są objęte: uszkodzenia powstałe wskutek używania nieoryginalnych akcesoriów i/lub sprzętu lub nieodpowiednich części zamiennych, a także demontaż lub modyfikacja produktu.

Gwarancja obejmuje tylko wadliwe części. W żadnym wypadku nie obejmuje ona kosztów dodatkowych (transport, robocizna) oraz szkód bezpośrednich lub następnych.

W ramach gwarancji Kupujący może uzyskać zwrot zapłaconej kwoty albo wymianę produktu lub jego naprawę lub inne usługi, których skutkiem będzie usunięcie wad produkcyjnych. Kupujący jest zobowiązany do współdziałania z Gwarantem przy realizacji swoich uprawnień wynikających z niniejszej gwarancji. Kupujący, który korzysta z uprawnień wynikających z niniejszej gwarancji powinien dostarczyć produkt na podany niżej adres Gwaranta lub do sklepu, w którym nabył produkt.

Gwarant zobowiązuje się do wykonania swoich obowiązków niezwłocznie, ale nie później niż w terminie 21 dni.

Udzielenie przez Gwaranta gwarancji nie wyłącza, nie ogranicza ani nie zawiesza uprawnień Kupującego wynikających z przepisów o rękojmi za wady rzeczy sprzedanej.

Producent:

UK Manufacturer:

Kingfisher International Products Limited,
1 Paddington Square, London, W2 1GG,
United Kingdom

EU Manufacturer:

Kingfisher International Products B.V.,
Rapenburgerstraat 175E,
1011 VM Amsterdam,
The Netherlands

PL www.castorama.pl

Aby zapoznać się z instrukcją obsługi online, odwiedź stronę www.kingfisher.com/products

WAŻNE - NALEŻY DOKŁADNIE PRZECZYTAĆ NINIEJSZE INFORMACJE I ZACHOWAĆ.

Siguranța

- ☑ Manevrați cu atenție uneltele folosite pentru construirea magaziei.
- ☑ Nu permiteți accesul copiilor și al animalelor în zona de asamblare.
- ☑ Anumite componente ale magaziei au margini ascuțite și pot cauza vătămări corporale. Purtați echipament de protecție personală: mănuși de lucru, îmbrăcăminte cu mâneci lungi și ochelari de protecție.
- ☑ Când utilizați uneltele electrice, purtați ochelari de protecție pentru a vă proteja ochii. Pentru a evita riscul de electrocutare, asigurați-vă că uneltele electrice sunt bine izolate.
- ☑ Când utilizați o scară, asigurați-vă că aceasta este stabilă pe sol. Nu vă sprijiniți niciodată cu toată greutatea pe acoperiș sau pe alte componente ale magaziei.
- ☑ Nu încercați să asamblați magazia în condiții de vânt puternic, deoarece zona de lucru poate deveni periculoasă.
- ☑ Când lucrați pe acoperiș, procedați cu atenție și utilizați echipament de siguranță adecvat.
- ☑ Asigurați-vă că nu așezați niciun obiect pe componentele magaziei, pentru a le menține în starea originală.
- ☑ Depozitați combustibilii și agenții corozivi în recipiente etanșate.
- ☑ Protejați magazia împotriva vânturilor puternice, prin fixare adecvată pe fundație.

Fundații

- ☑ Înainte de a instala magazia, consultați reglementările de planificare locale.
- ☑ Alegeți o locație adecvată și lăsați suficient spațiu de lucru în jurul magaziei.
- ☑ Înainte de a începe asamblarea magaziei, asigurați-vă că aveți o fundație bună.
- ☑ Magazia trebuie construită pe o fundație solidă, orizontală. Pentru o bază adecvată, vă recomandăm să utilizați beton armat sau dale de beton de dimensiuni mari.
- ☑ În cazul unei fundații din beton armat, pregătiți un strat inițial de pietre/pietriș. Fundația trebuie să aibă o grosime minimă de 10 cm. Lăsați cimentul să se usuce minimum 48 de ore.

- ☑ Asigurați-vă că fundația este nivelată și că permite scurgerea apei pentru a evita înghețul.
- ☑ Dacă pământul riscă să înghețe, fundațiile trebuie să se afle sub linia de îngheț, în caz contrar este necesară instalarea unei dale de izolare pentru a nu permite înghețului să afecteze structura.
- ☑ Verificați fiecare dimensiune a magaziei pentru a vă asigura că acestea se fixează perfect pe fundație.
- ☑ Pentru a evita ridicarea umezelii prin pereți, izolați întotdeauna prima scândură dinspre dală cu ajutorul unei benzi de nivel (nefumizată cu adăposturile de grădină).
- ☑ Fundațiile realizate cu atenție sunt esențiale pentru o construcție reușită. Fundațiile trebuie să fie perfect nivelate. Fundațiile și structura trebuie să rămână orizontale. Chiar și după construcție, structura din lemn trebuie să se poată dilata și contracta în mod natural.
- ☑ AVERTISMENT: Dacă nu construiți magazia într-o singură sesiune, vă recomandăm să o depozitați în interior sau într-un loc protejat. În acest caz, nu dezamblați produsul. Pentru a preveni contactul cu umezeala, nu așezați produsul direct pe pământ. Este important ca locația de depozitare să fie orizontală, în caz contrar existând riscul de curbare a grinzilor longitudinale din lemn.

Durata și condițiile de garanție

Acordăm o atenție specială selectării unor materiale de înaltă calitate și folosim tehnici de fabricație care ne permit să creăm game de produse elegante și durabile.

Din acest motiv, oferim o 5 ani garanție (excluzând materialele acoperișului), 1 an pentru toate elementele de asamblare și montare și 2 ani pentru tâmplărie pentru defectele de manoperă ale produsului.

Acest produs dispune de o garanție de 5 ani de la data achiziției în cazul utilizării casnice obișnuite, în condiții neprofesionale. Garanția se va aplica doar la prezentarea chitanței sau a facturii. Păstrați dovada achiziției într-un loc sigur.

Garanția acoperă avariile și defecțiunile produsului cu condiția ca acesta să fie utilizat conform destinației sale și să fie instalat și întreținut în conformitate cu bunele practici și cu informațiile conținute în manualul de utilizare.

Acest produs trebuie instalat astfel încât să poată fi demontat ulterior fără a fi deteriorat.

Această garanție contractuală nu acoperă defectele și deteriorările cauzate de uzura normală a pieselor, condiții meteorologice nefavorabile, inundații, eliberări de căldură, îngheț, deteriorările cauzate de calitatea apei (duritate, agresivitate, coroziune etc.), de prezența unor corpuri străine transportate de apă sau în alt mod (nisip, pilitură etc.) sau de lipsa ventilației spațiului sau deteriorările care pot fi consecința utilizării necorespunzătoare, a întrebuințării greșite, a neglijenței, a accidentelor sau a operațiilor de întreținere defectuoase sau care nu se conformează bunelor practici sau informațiilor din manualul de utilizare.

Următoarele sunt, de asemenea, excluse de garanție: consecințele negative ale utilizării de accesorii și/sau de echipamente neoriginale sau de piese de schimb necorespunzătoare, ale demontării sau ale modificării produsului.

Garanția se limitează la acele părți care se constată a fi defecte. În niciun caz nu va acoperi cheltuielile secundare (deplasare, manoperă) și daunele directe și pe cale de consecință.

Acest lucru nu afectează drepturile dumneavoastră statutare. Această garanție nu acoperă kitul de evacuare.

Vă rugăm să rețineți că un certificat de garanție suplimentar va fi dat în magazinul din care veți achiziționa produsul.

Producător:

UK Manufacturer:

Kingfisher International Products Limited,
1 Paddington Square, London, W2 1GG,
United Kingdom

EU Manufacturer:

Kingfisher International Products B.V.,
Rapenburgerstraat 175E,
1011 VM Amsterdam,
The Netherlands

RO www.bricodepot.ro

Pentru a consulta manualele de instrucțiuni online,
vizitați www.kingfisher.com/products

IMPORTANT – PĂSTRAȚI ACESTE INFORMAȚII PENTRU REFERINȚE VIITOARE: CITIȚI CU ATENȚIE.



EAN: 3663602713500 / 5059340844350

- EN** 34 mm Timber Shed with a 10 m² Double Pent Roof
- PL** Domek narzędziowy drewniany 34 mm z dachem dwuspadowym 10 m²

- FR** Abri de jardin en bois ép. 34 mm avec toit à 2 pentes de 10 m²
- RO** Căsuță de grădină din lemn de 34 mm cu acoperiș în două ape de 10 m²



EN IMPORTANT - Please read carefully the separate safety guide before use.

FR IMPORTANT - Lire attentivement le guide de sécurité séparé avant utilisation.

PL WAŻNE - Przed użyciem proszę dokładnie zapoznać się z instrukcją bezpieczeństwa.

RO IMPORTANT - Vă rugăm să citiți cu atenție ghidul de siguranță separat înainte de utilizare.

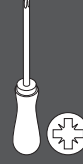
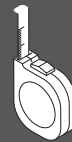
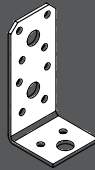
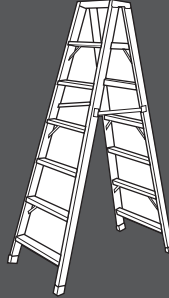
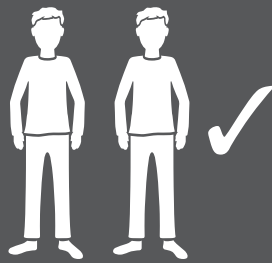

[001] x 1
34 x 114 x 4000 mm

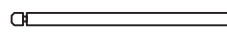

[002] x 10
34 x 114 x 1882 mm



[003] x 22
34 x 114 x 612 mm



[004] x 6
34 x 114 x 612 mm



[010] x 17
34 x 114 x 4000 mm



[011] x 2
34 x 57 x 3000 mm

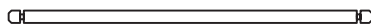

[012] x 32
34 x 114 x 3000 mm

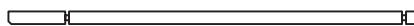

[013] x 1
34 x 120 x 3400 mm

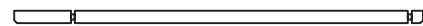

[014] x 1
34 x 120 x 3400 mm



[W1-1] x 1
570 x 4000 mm



[W2-1] x 1
570 x 4000 mm



[A-PR1] x 5
44 x 140 x 3400 mm



[DB] x 76
90 x 15 x 2150 mm



[DPL] x 4
15 x 45 x 2200 mm



[DPP-1] x 5
3500 mm



[TB] x 2
15 x 45 x 3400 mm



[KFS] x 4
22 x 45 x 2050 mm

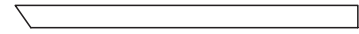

[GM] x 4
15 x 120 x 2200 mm

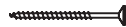

[HS1] x 12
2.5 x 20 mm

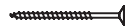

[HS4] x 21
3 x 30 mm

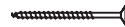

[HS9] x 34
3.5 x 50 mm



[HS10] x 18
4 x 25 mm



[HS11] x 16
4 x 30 mm



[HS12] x 15
4 x 40 mm



[HS16] x 2
5 x 90 mm



[HS18] x 14
5 x 120 mm



[HS31] x 2
3 x 15 mm



[SH34] x 1



[SFS] x 8
D6



[NF4] x 332
2 x 50 mm



[NF5] x 20
2 x 40 mm



[NF6] x 144
2.8 x 15 mm



[BFS] x 8
6 x 70 mm



[DFS] x 8
D6



[TUK.2.034.SVP.MMXT34] x 1
1494 x 1836 mm



[1] x 1
72 x 100 x 1438 mm



[2] x 1
72 x 80 x 1836 mm



[3] x 1
72 x 80 x 1836 mm



[4] x 1
14 x 36 x 1494 mm



[5] x 1
13 x 32 x 1812 mm

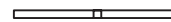

[6] x 2
15 x 25 x 608 mm



[7] x 2
15 x 25 x 536 mm

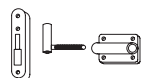

[BH] x 4

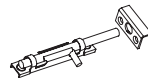

[TL] x 2



[TL4] x 1



[TL5] x 2



[CL] x 1

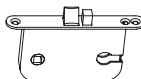

[DL] x 1



[SFL] x 1

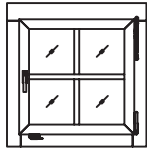

[AK.1.104.SSP.Tg] x 1
646 x 646 mm



[1] x 1
15 x 25 x 536 mm

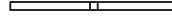

[2] x 1
15 x 25 x 521 mm



[FS1] x 1



[FSP] x 2

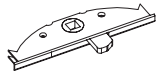

[FSL] x 1



[FSA] x 1



[NA1] x 1

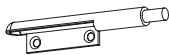

[NA2] x 1



[NA3] x 1

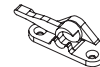

[NA4] x 1



[NA5] x 1

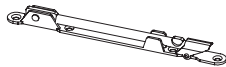

[NA6] x 1



EN Exploded view
 PL Rysunek złożeniowy

FR Vue explosée
 RO Vedere în spațiu

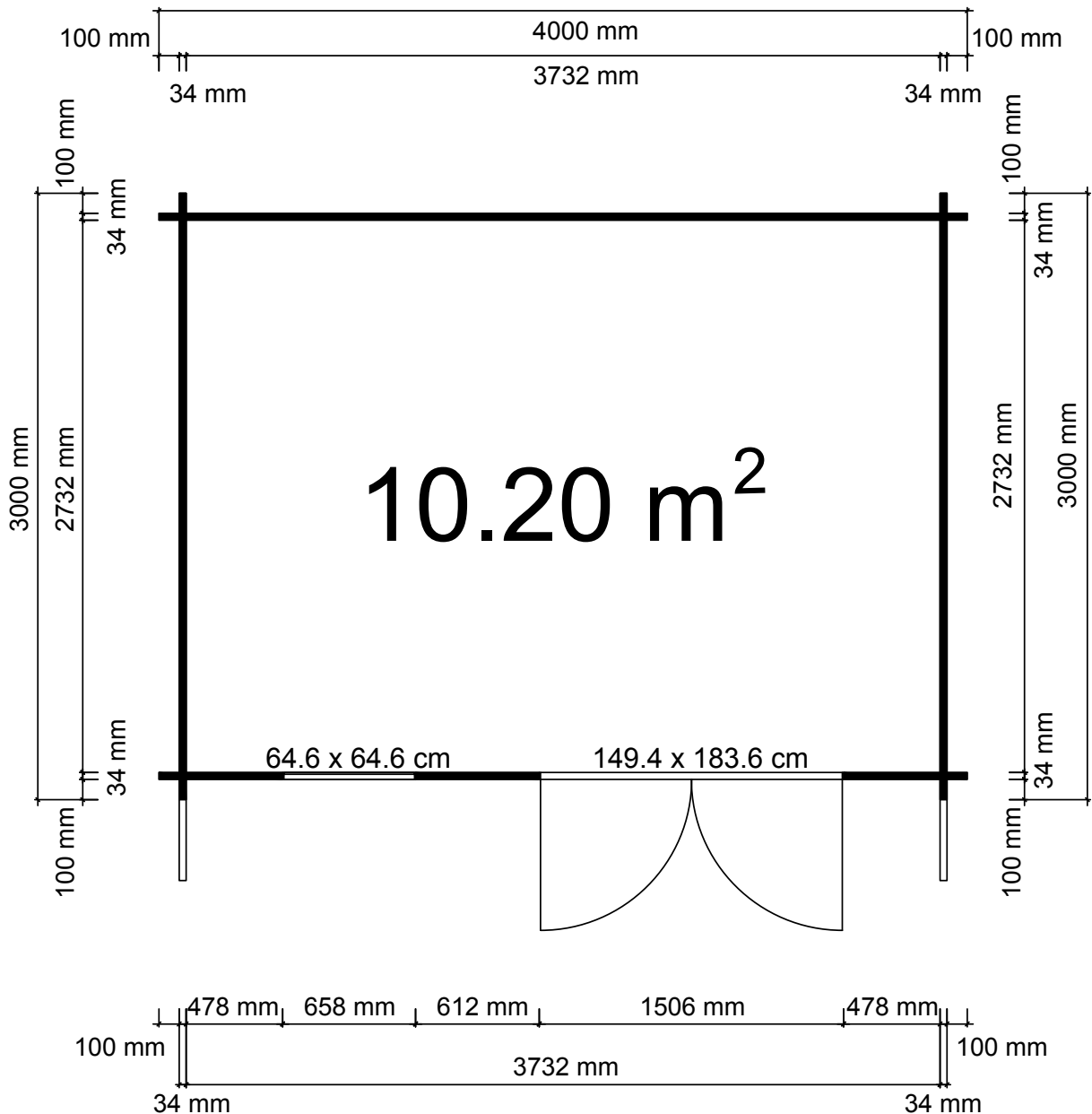
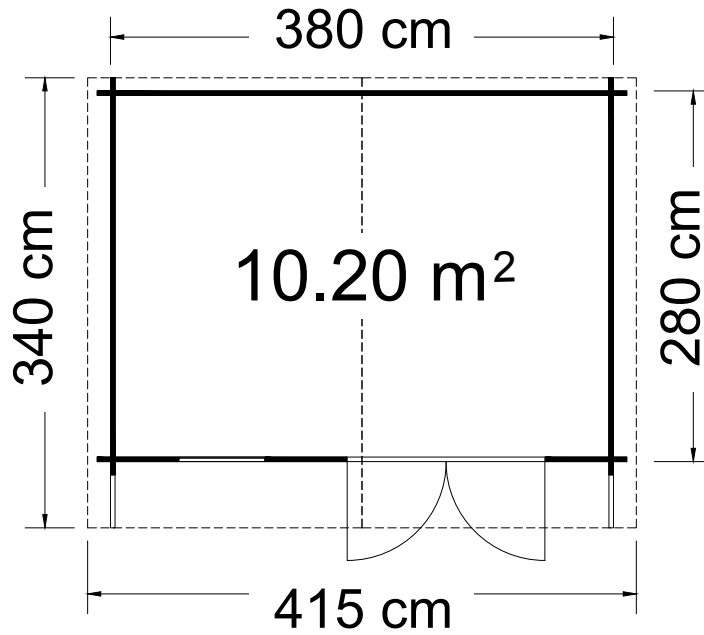

C

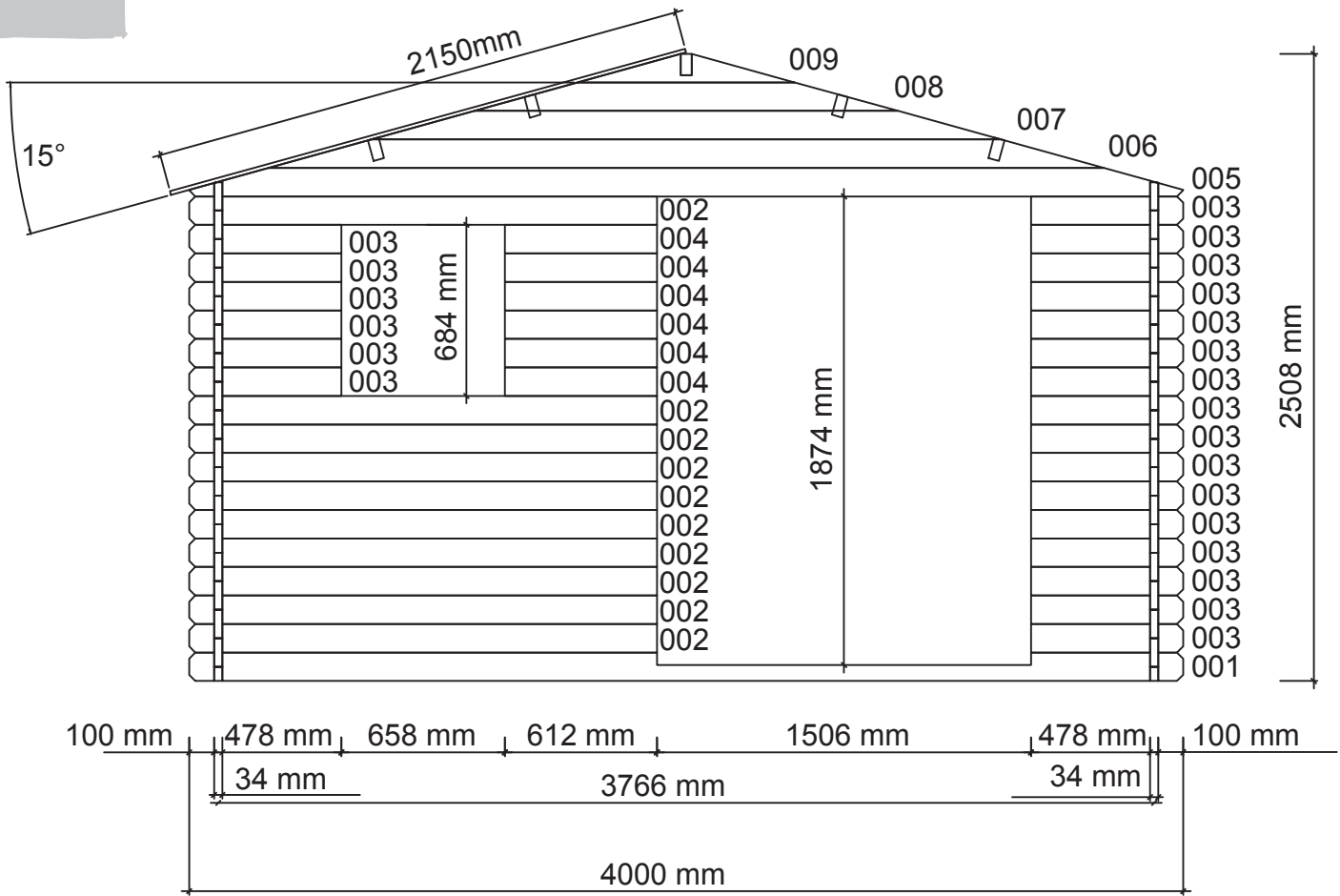

D

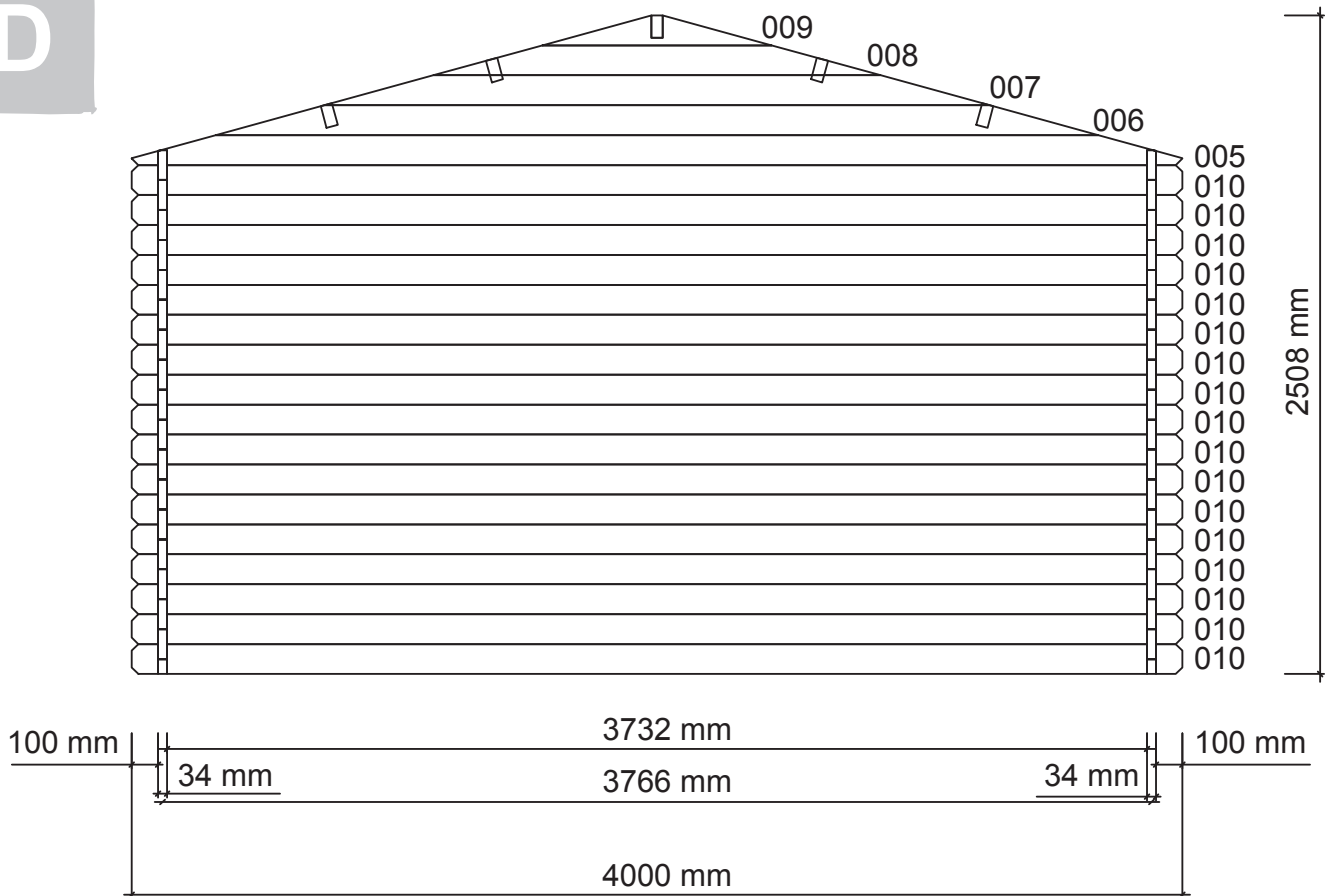

E

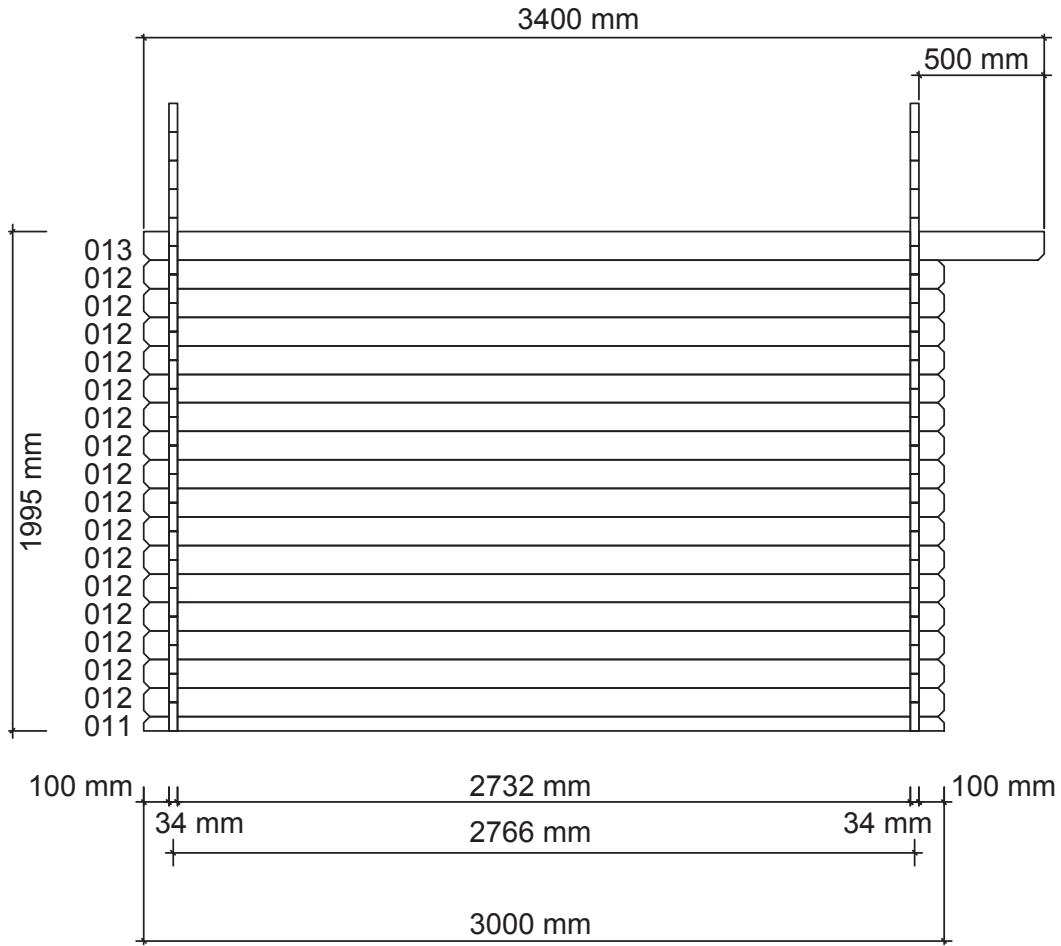

F

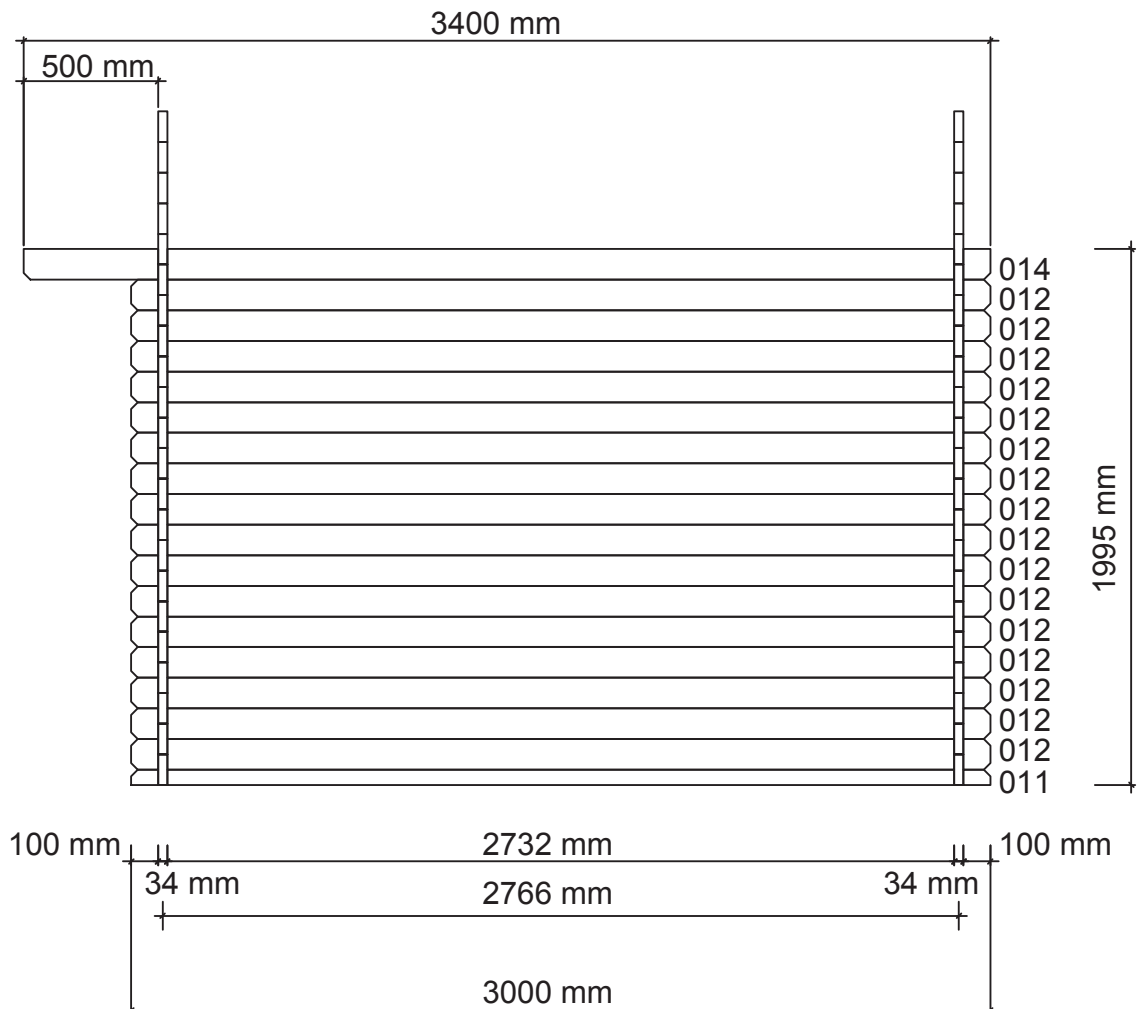



EN Foundation
PL Fundament

FR Fondation
RO Fundația

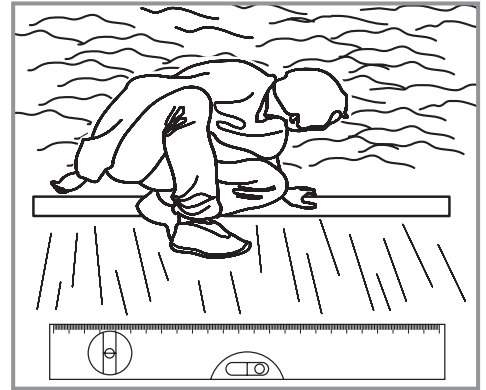

EN Level ground required

FR Sol nivelé requis

PL Wymagane wyrównanie i wypoziomowanie podłoża

RO Necesar teren plat

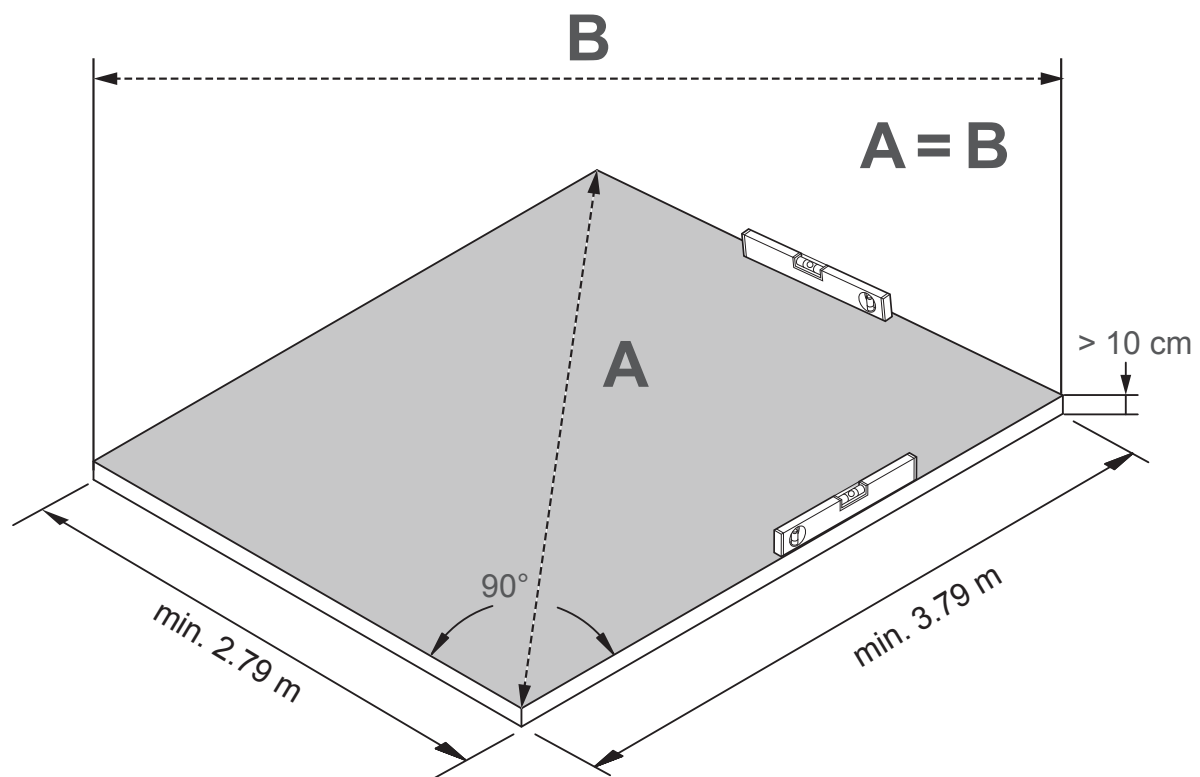

EN Preparing the concrete foundation

FR Préparation de la fondation en béton

PL Przygotowanie fundamentu z betonu

RO Pregătirea fundației din beton



EN Installation
 PL Instalacja

FR Installation
 RO Instalare



- EN **WARNING:** When power tools are used during assembly (pre-drilling & screwing), please ensure torque limit is set to not damage the wood.
- FR **AVERTISSEMENT :** Lorsque des outils électroportatifs sont utilisés pendant le montage (pré-perçage et vissage), s'assurer que la limite de couple est réglée de façon à ne pas endommager le bois
- PL **OSTRZEŻENIE:** W przypadku użycia elektronarzędzi podczas montażu (nawiercania i wkręcania) należy ustawić moment obrotowy tak, aby nie uszkodzić drewna.
- RO **AVERTISMENT:** Când sunt utilizate unelte electrice în timpul asamblării (găurire prealabilă și înșurubare) asigură-te că limita cuplului este setată astfel încât să nu deterioreze lemnul.

1A

- [001] x 1
- [010] x 1
- [011] x 2

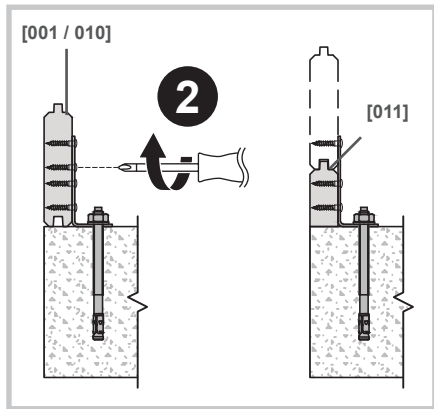

- EN Laying on concrete slabs (not included)
- FR Pose sur dalle béton (non inclus)
- PL Układanie na płytach betonowych (nie zawartych w zestawie)
- RO Întinderea pe dale din beton (neinclus)

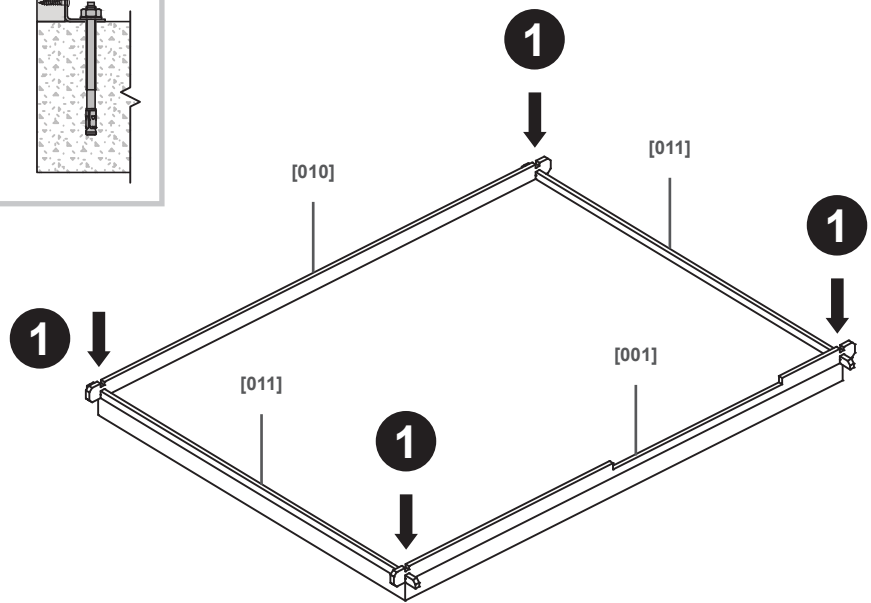

1B

- [001] x 1
- [010] x 1
- [011] x 2

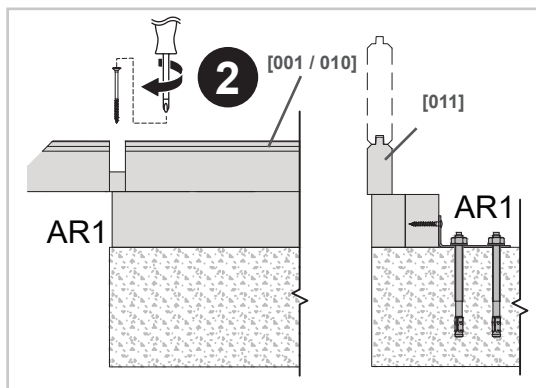

AR1 = EAN: 3663602713517

- EN Laying on wooden floor (not included)
- FR Pose sur plancher (non inclus)
- PL Układanie na drewnianej podłodze (brak w zestawie)
- RO Întinderea pe parchet din lemn (neinclus)

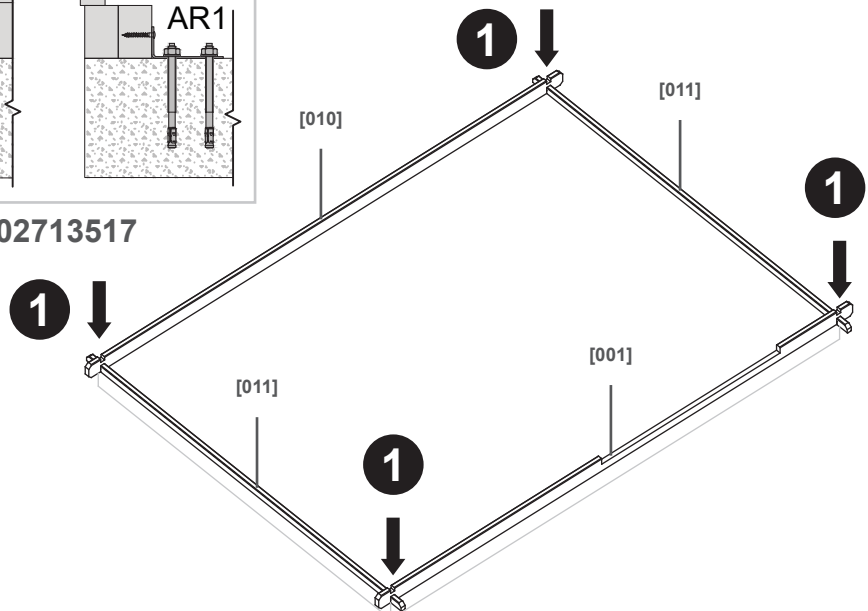

02



[1] x 1



[2] x 1



[3] x 1



[HS16] x 2

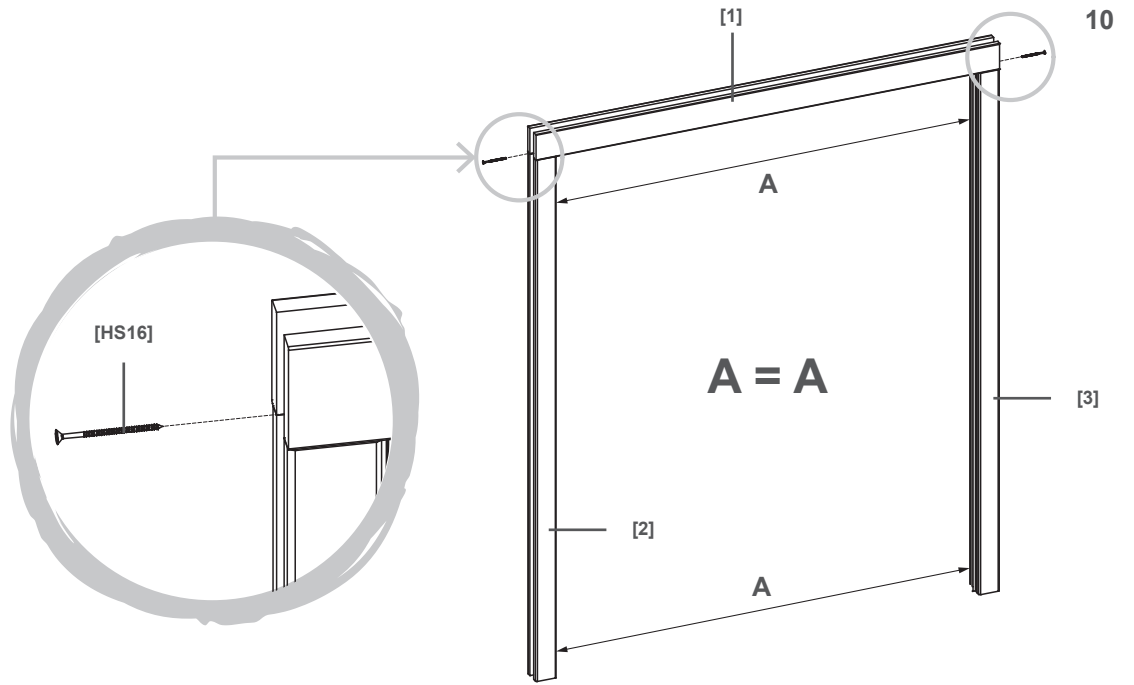

03



[002] x 9



[003] x 21



[004] x 6



[010] x 16



[012] x 32



[HS9] x 2



[HS12] x 3

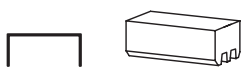

[4] x 1

[HS34] x 1

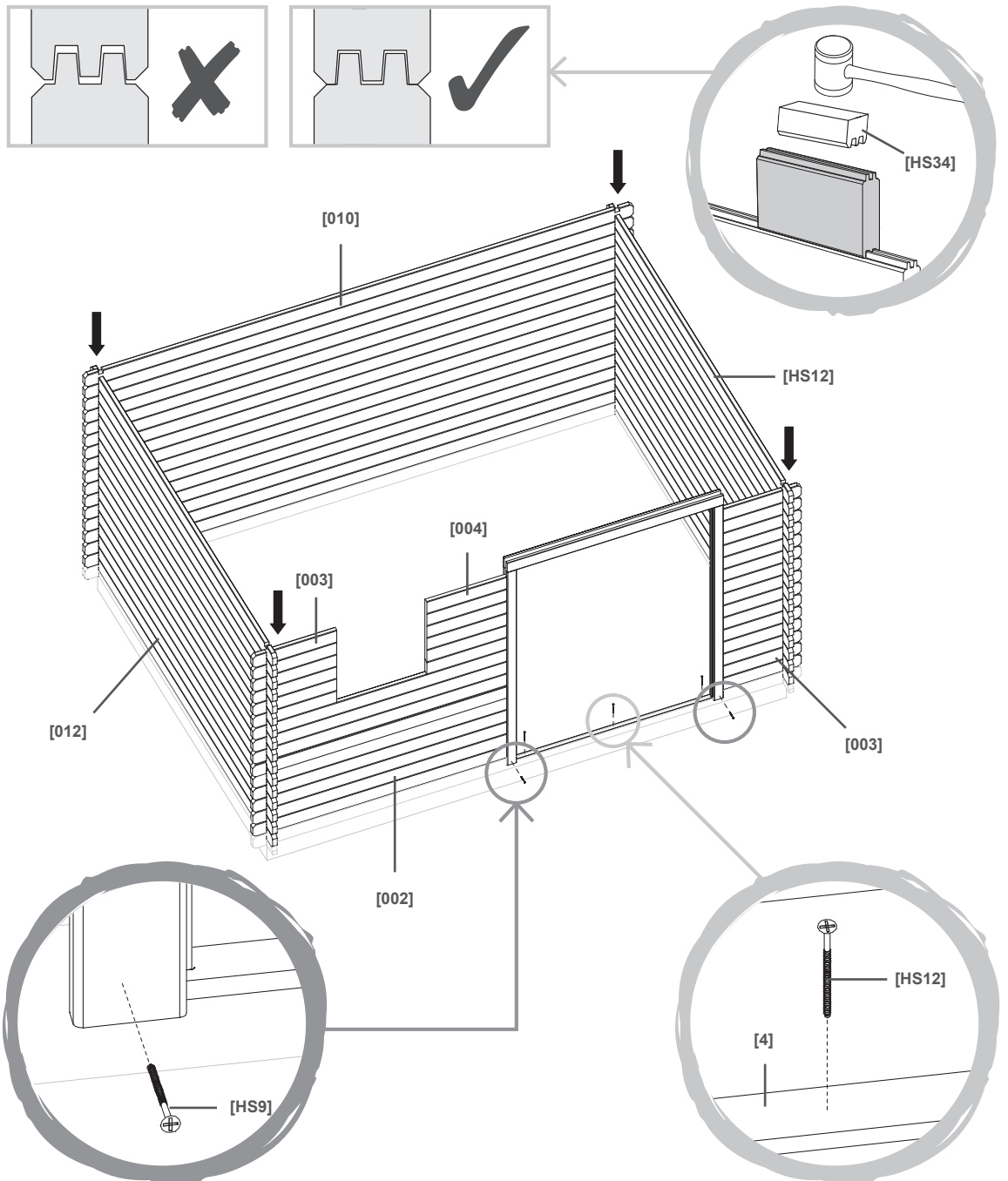
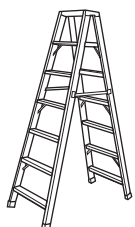

04



[AK.1.104.SSP.Tg] x 1



[FS1] x 1

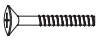

[FSP] x 2

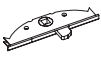

[FSL] x 1



[FSA] x 1



[HS31] x 2

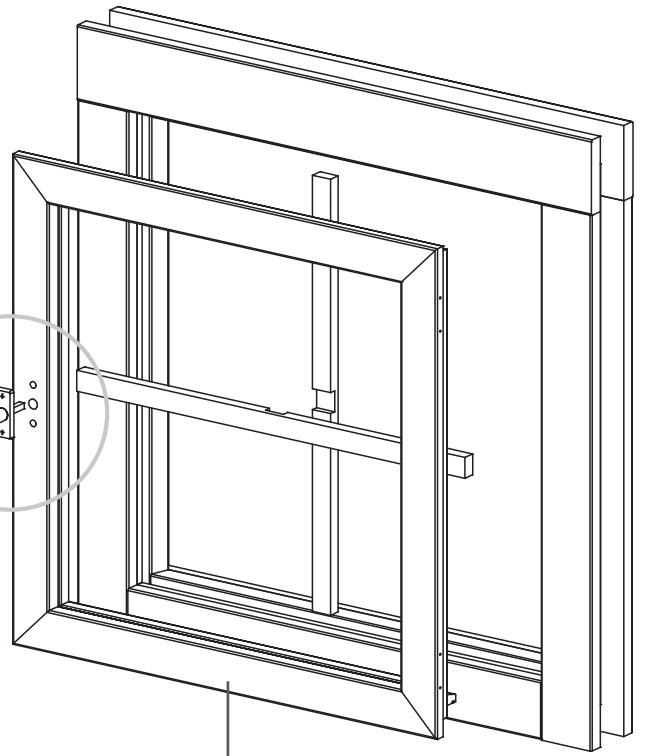
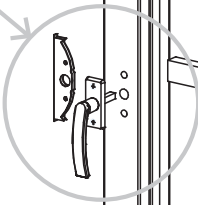
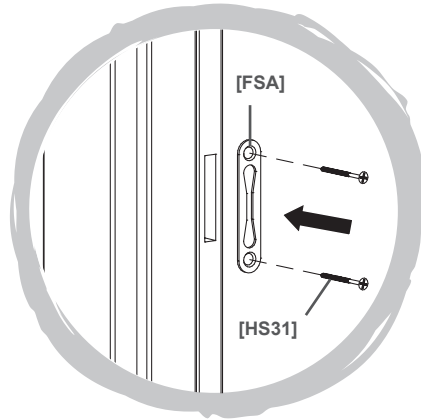
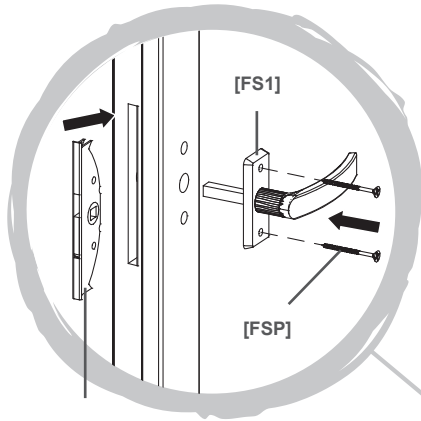

[AK.1.104.SSP.Tg]

05



[NA1] x 1

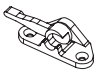

[NA4] x 1



[HS10] x 4

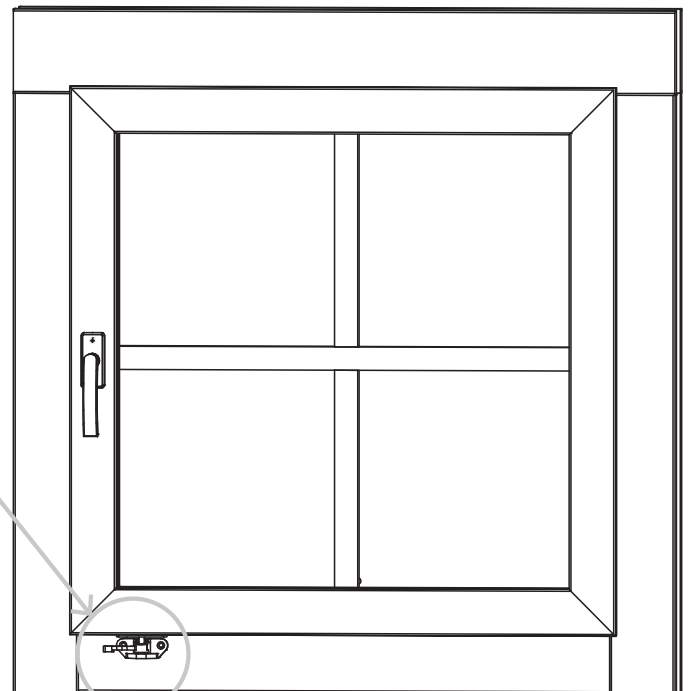
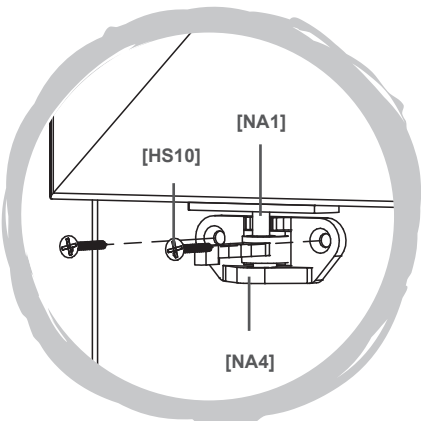
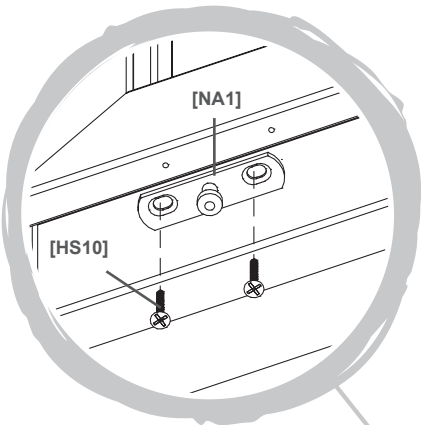

06

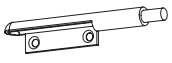

[NA2] x 1



[NA5] x 1



[HS10] x 4

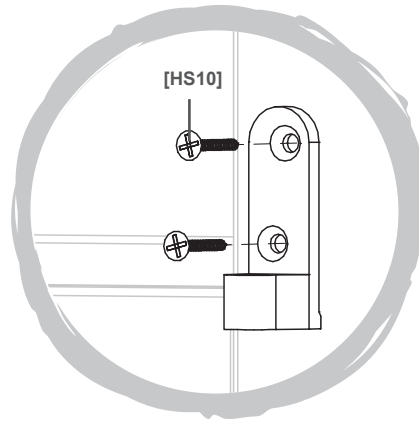
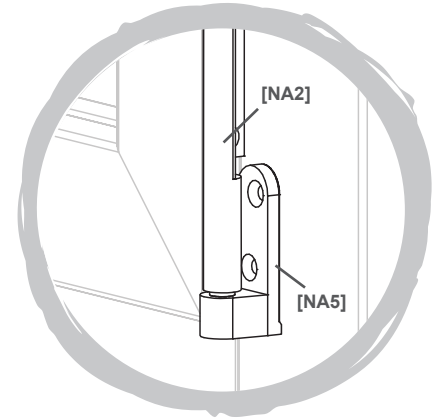
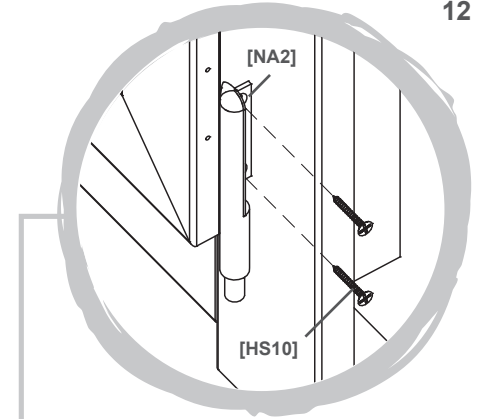
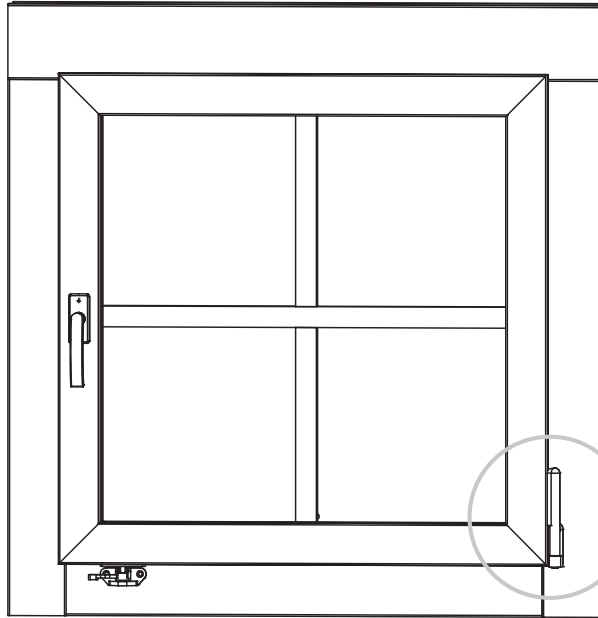

07



[NA3] x 1

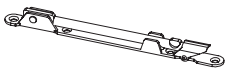

[NA6] x 1



[HS10] x 6

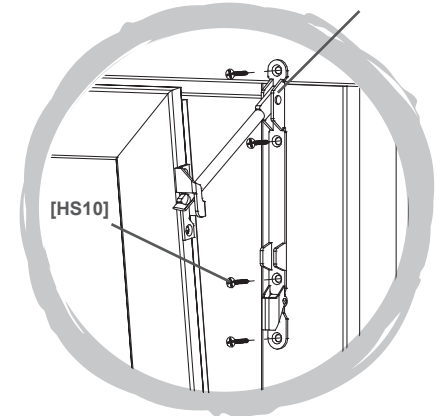
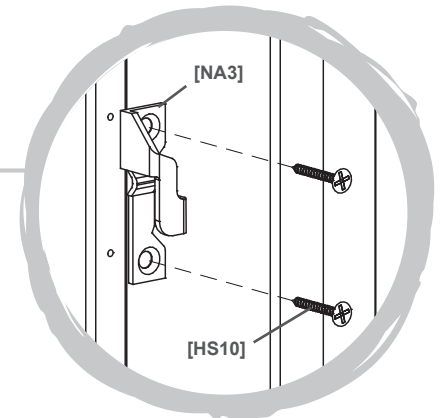
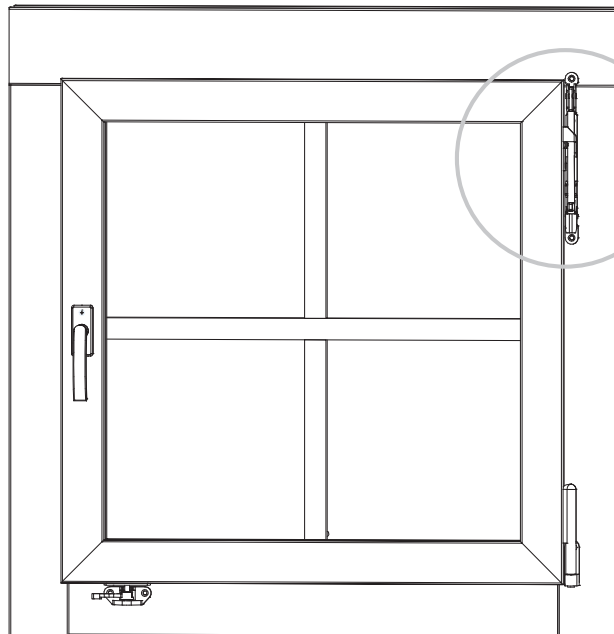

08



[1] x 1



[2] x 1



[HS1] x 4

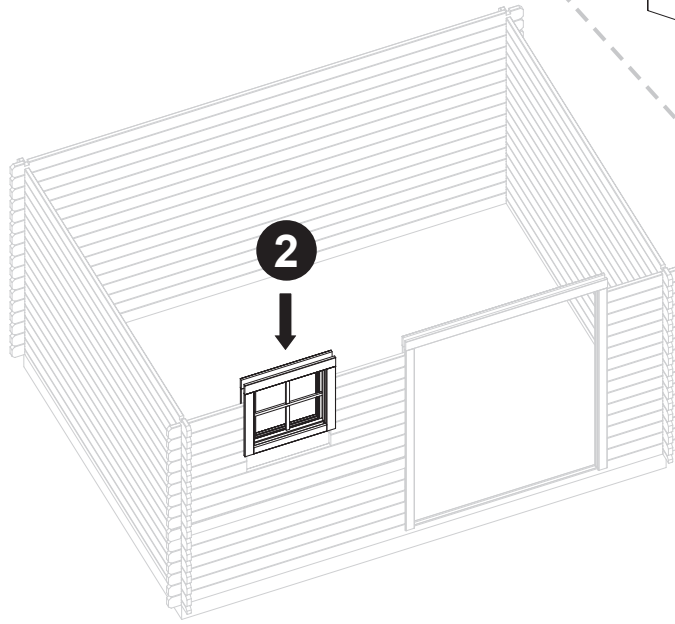
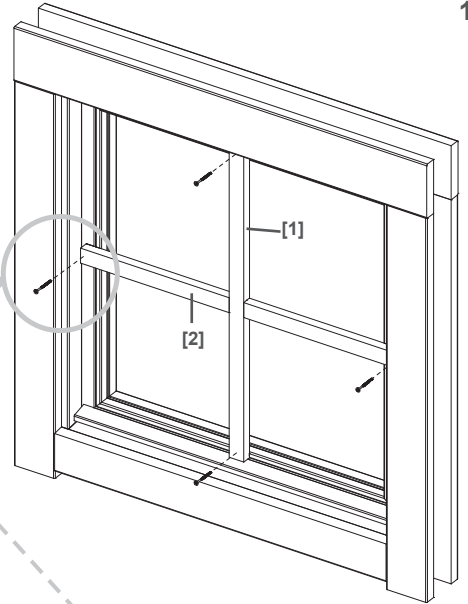
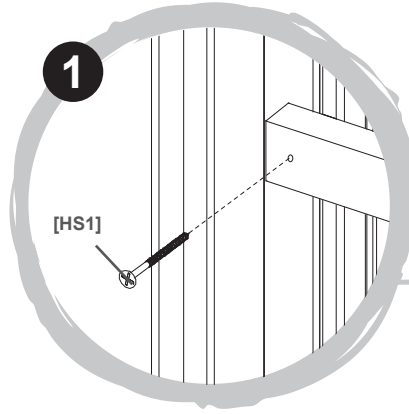

09



[002] x 1



[003] x 1



[013] x 1



[014] x 1

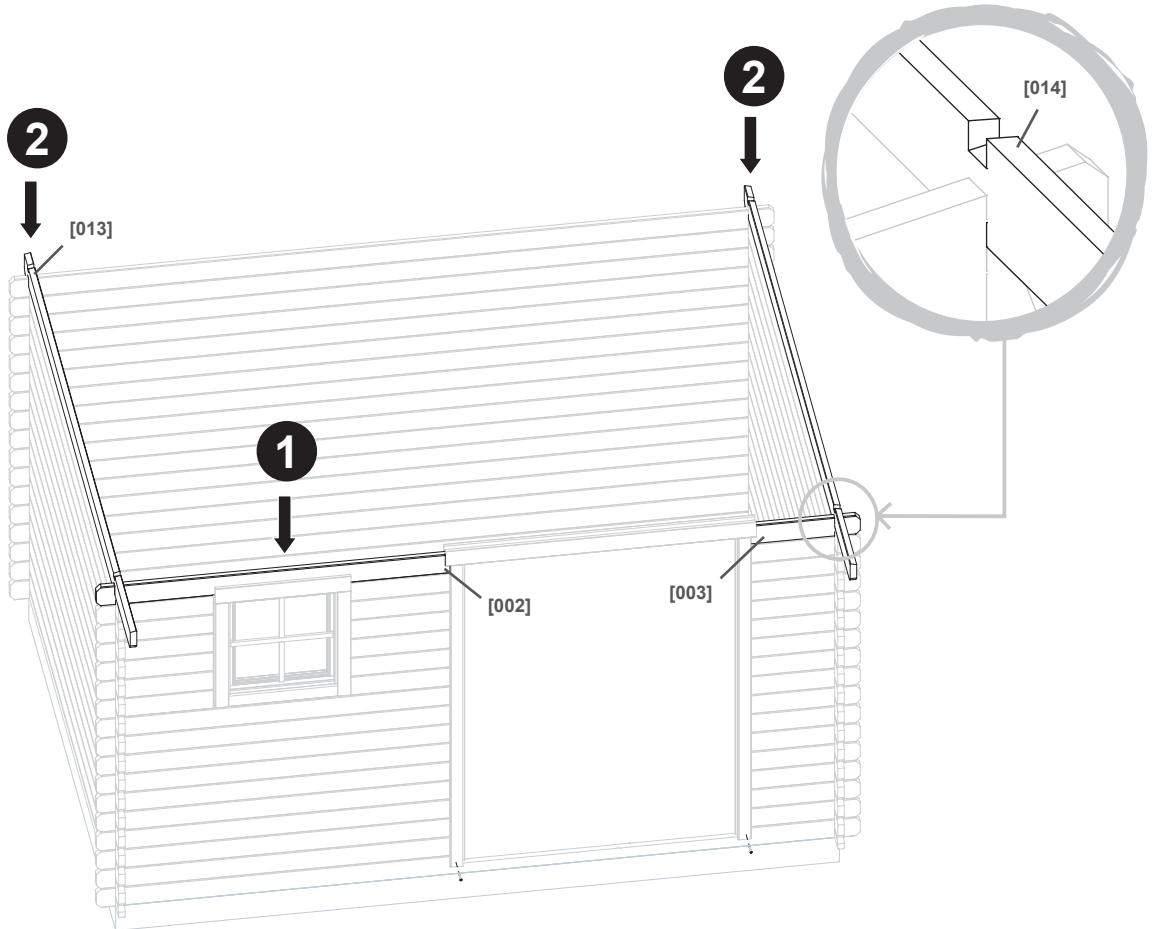

10



[W1-1] x 1



[W2-1] x 1



[HS18] x 4

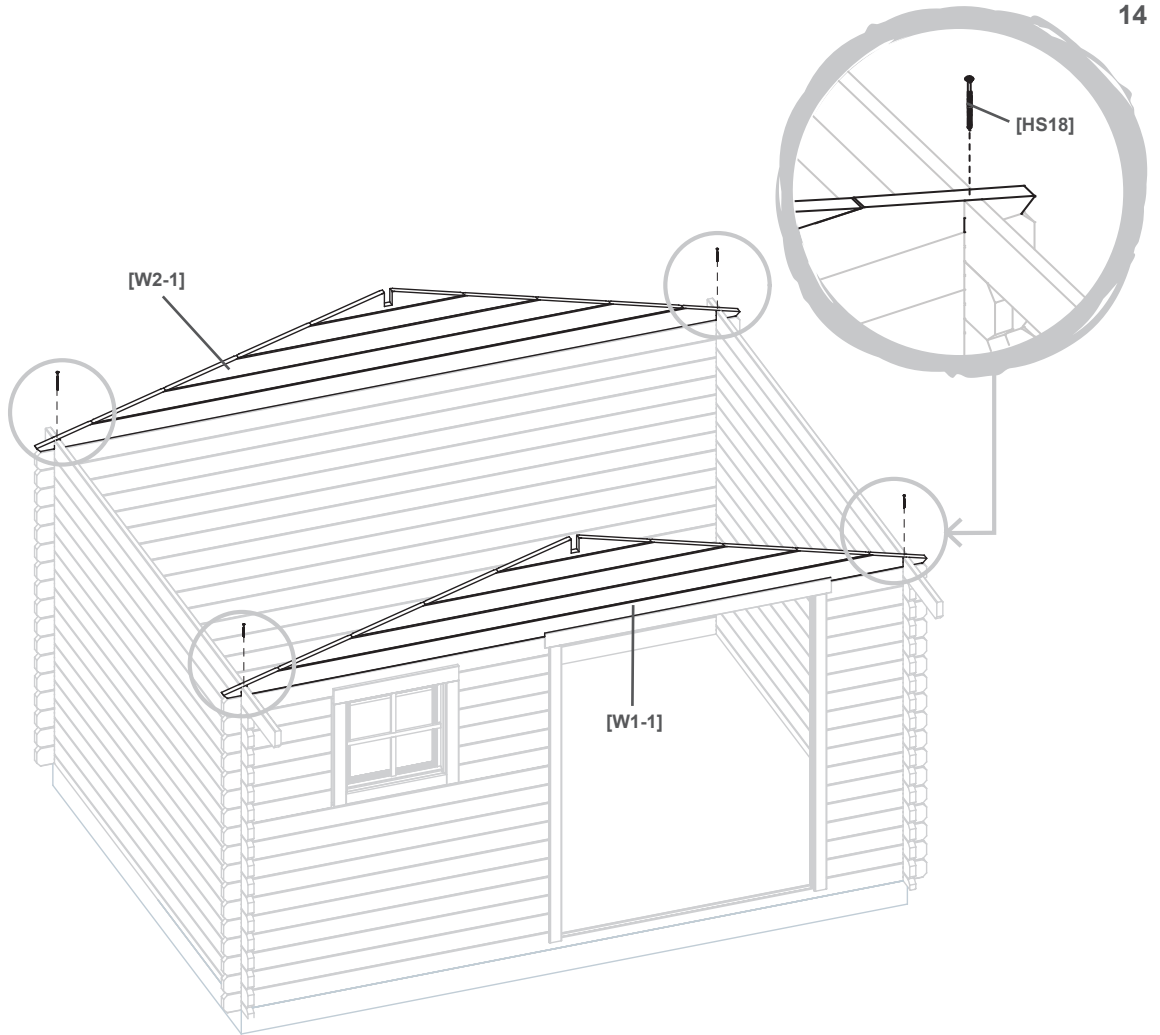

11

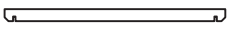

[A-PR1] x 5



[HS18] x 10

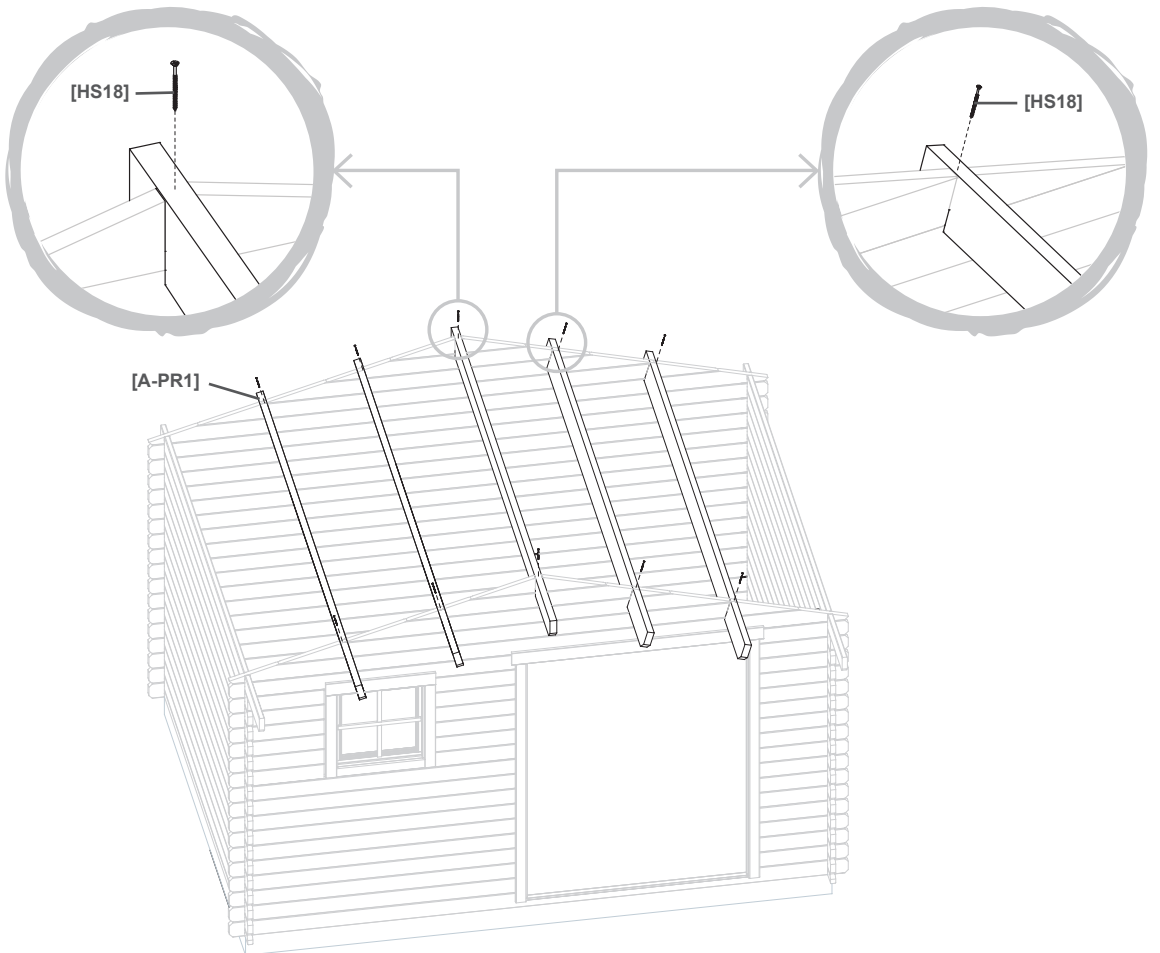

12



[KFS] x 4



[SFS] x 8



[BFS] x 8



[DFS] x 8

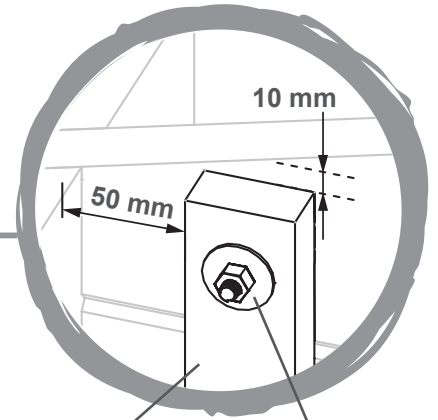
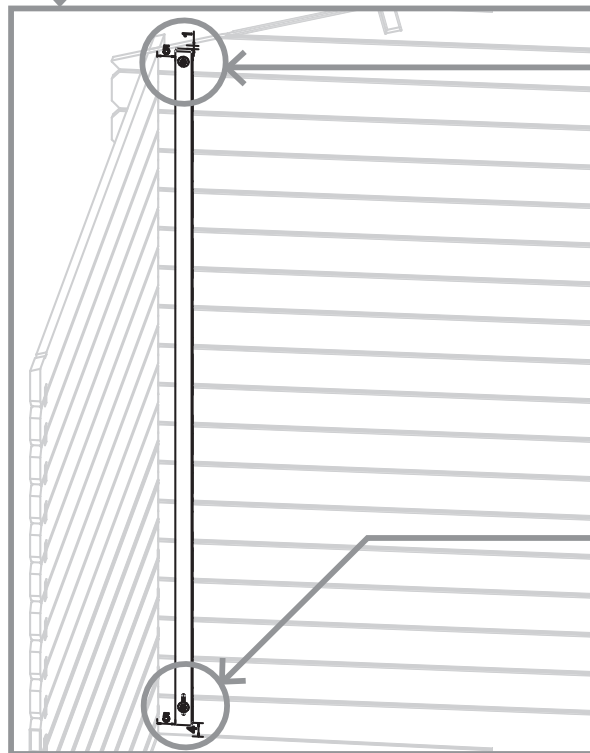
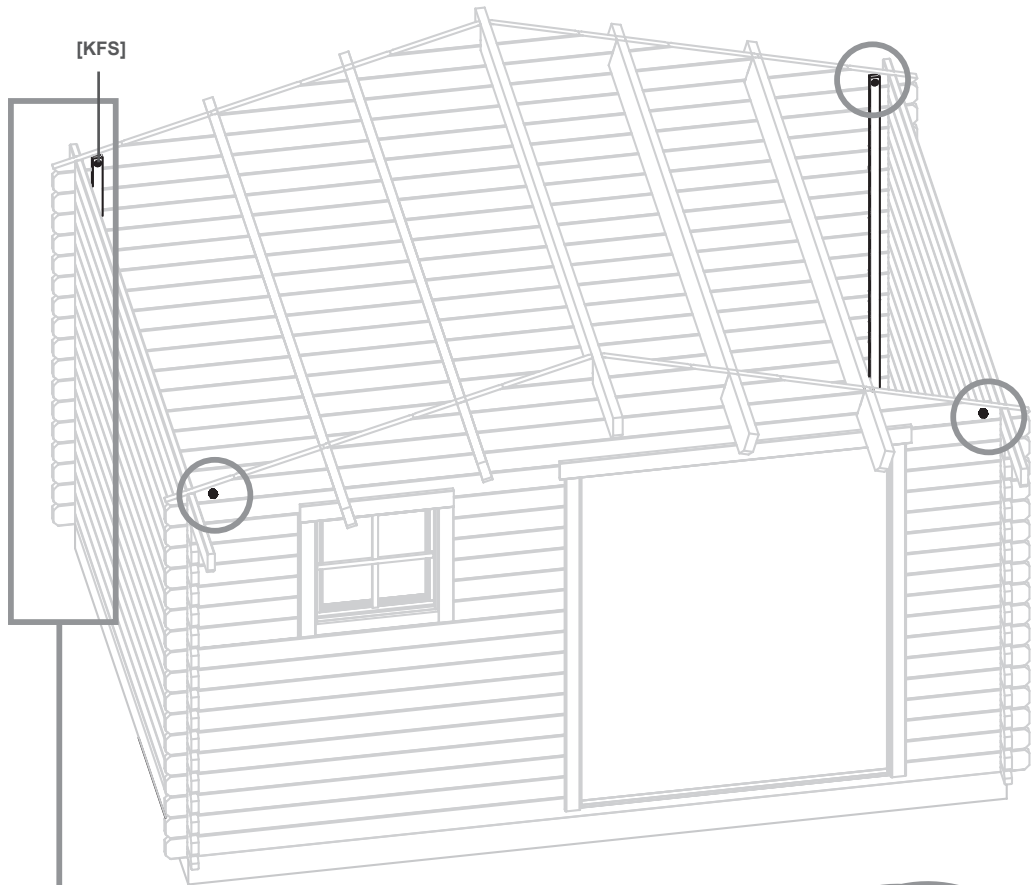

[KFS-1]

[DFS] / [SFS] / [BFS]

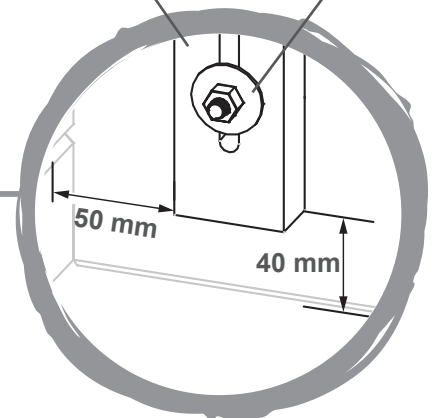

13



[DB] x 76



[NF4] x 332

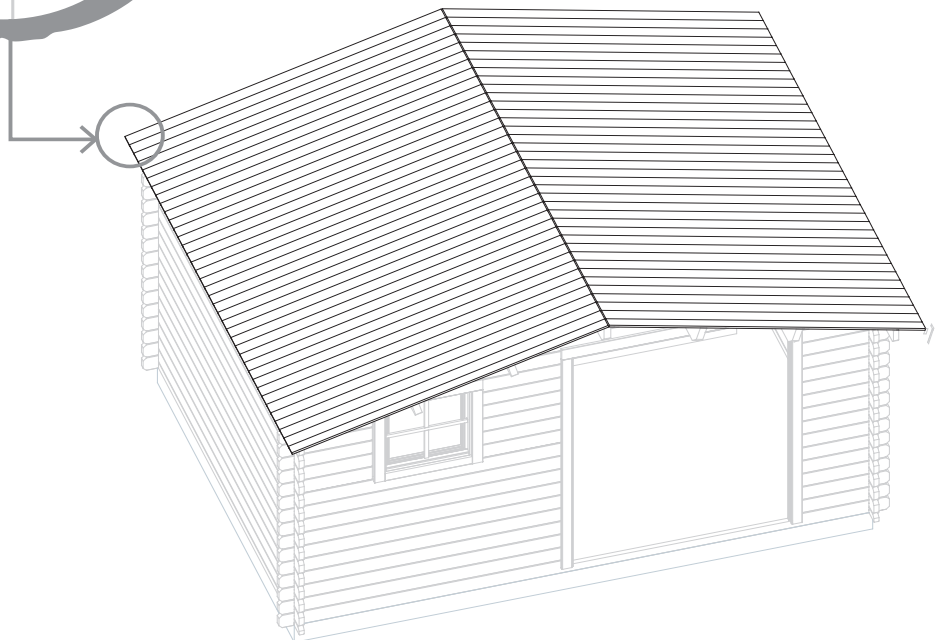
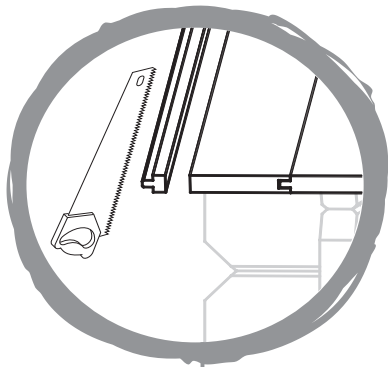
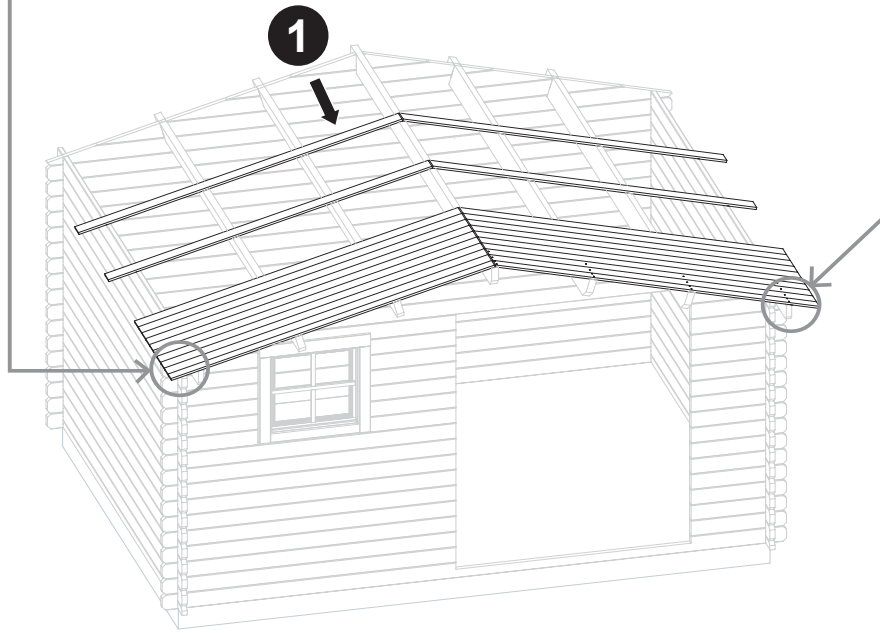
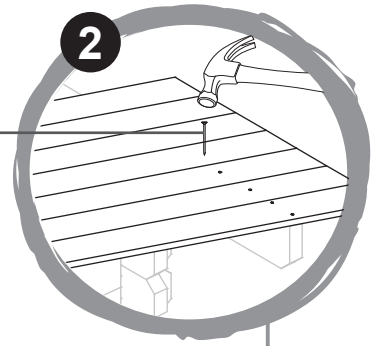
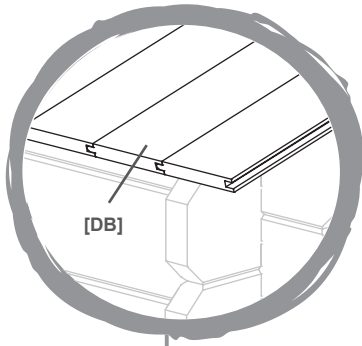

14



[TB] x 2



[DPP-1] x 5



[HS4] x 16



[NF6] x 144

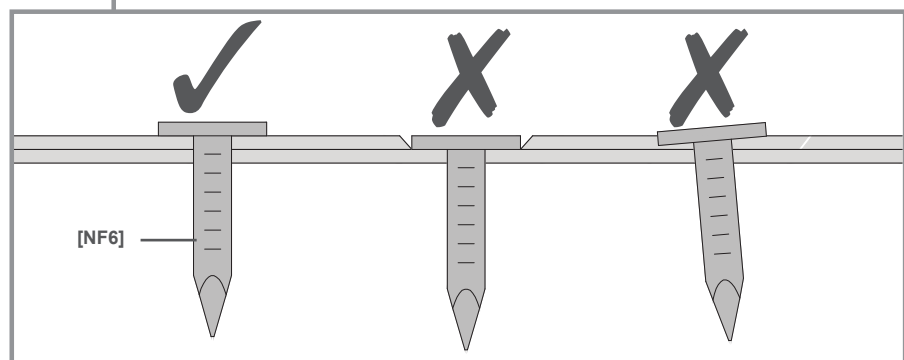
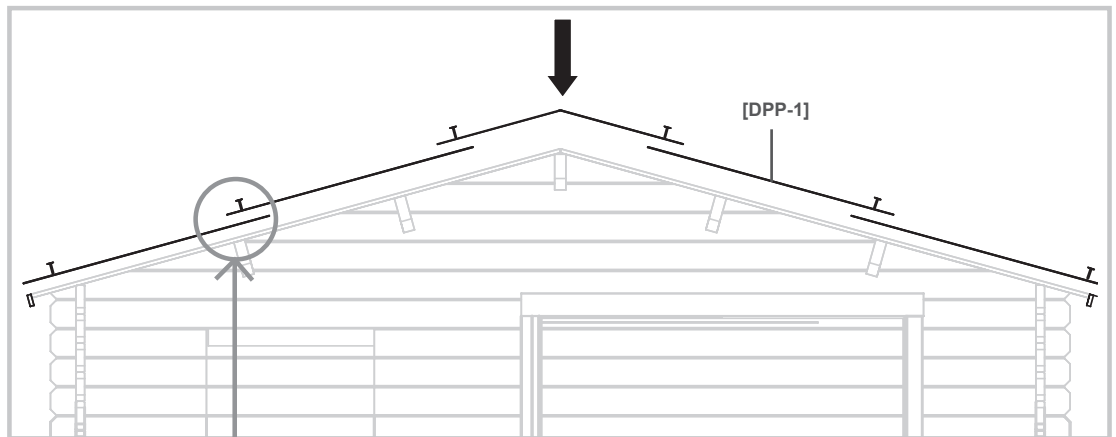
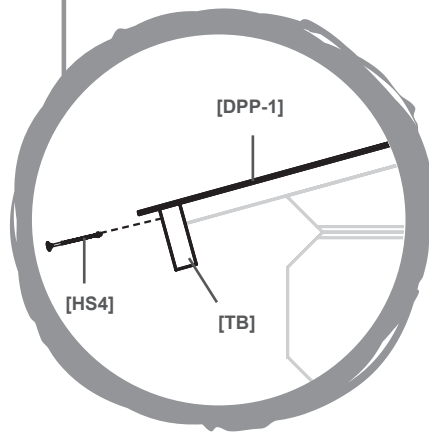
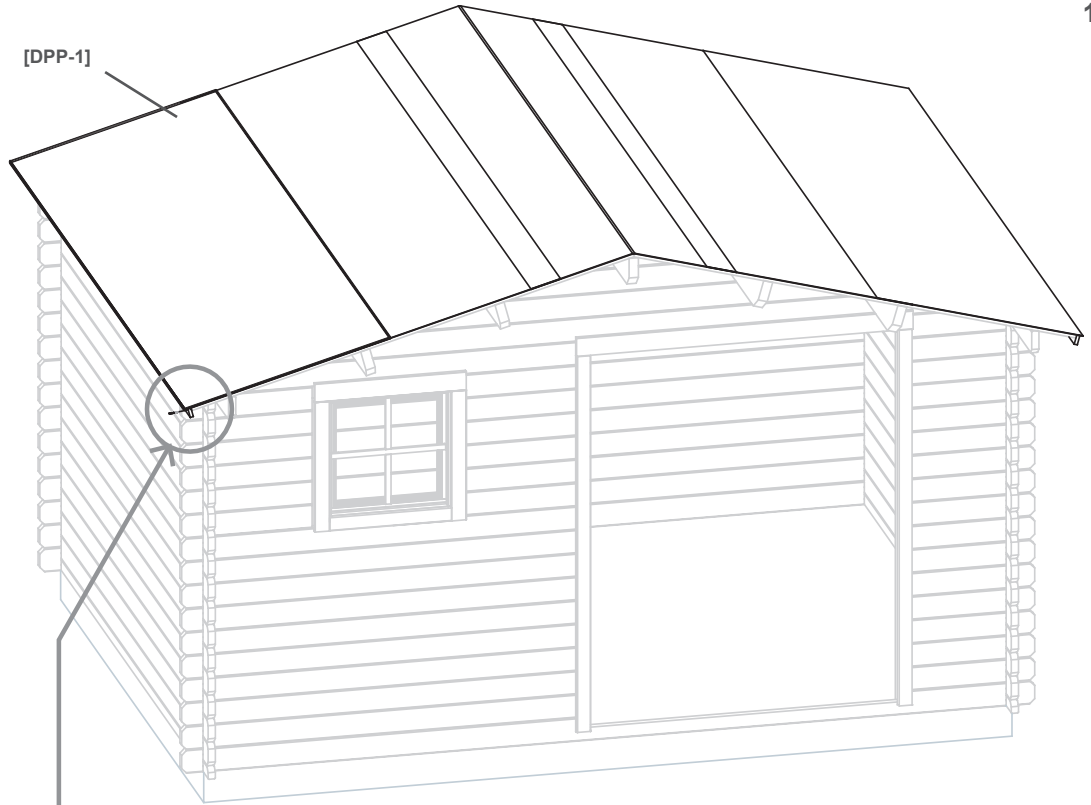

15

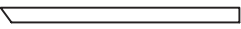

[GM] x 4



[DPL] x 4



[HS9] x 32



[NF5] x 20

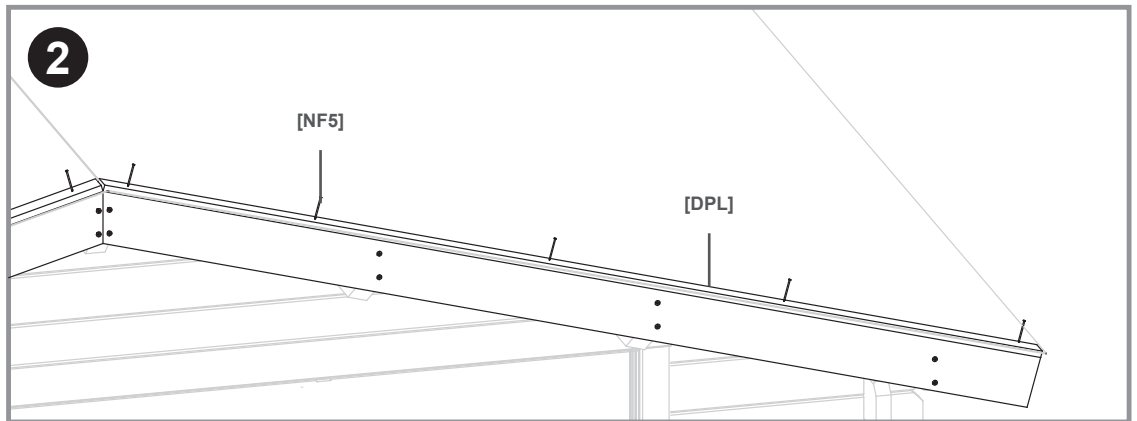
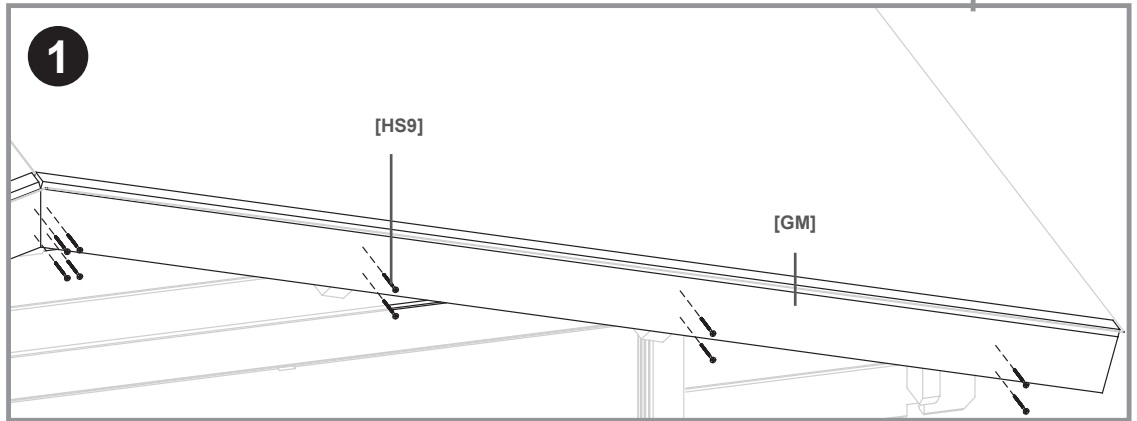
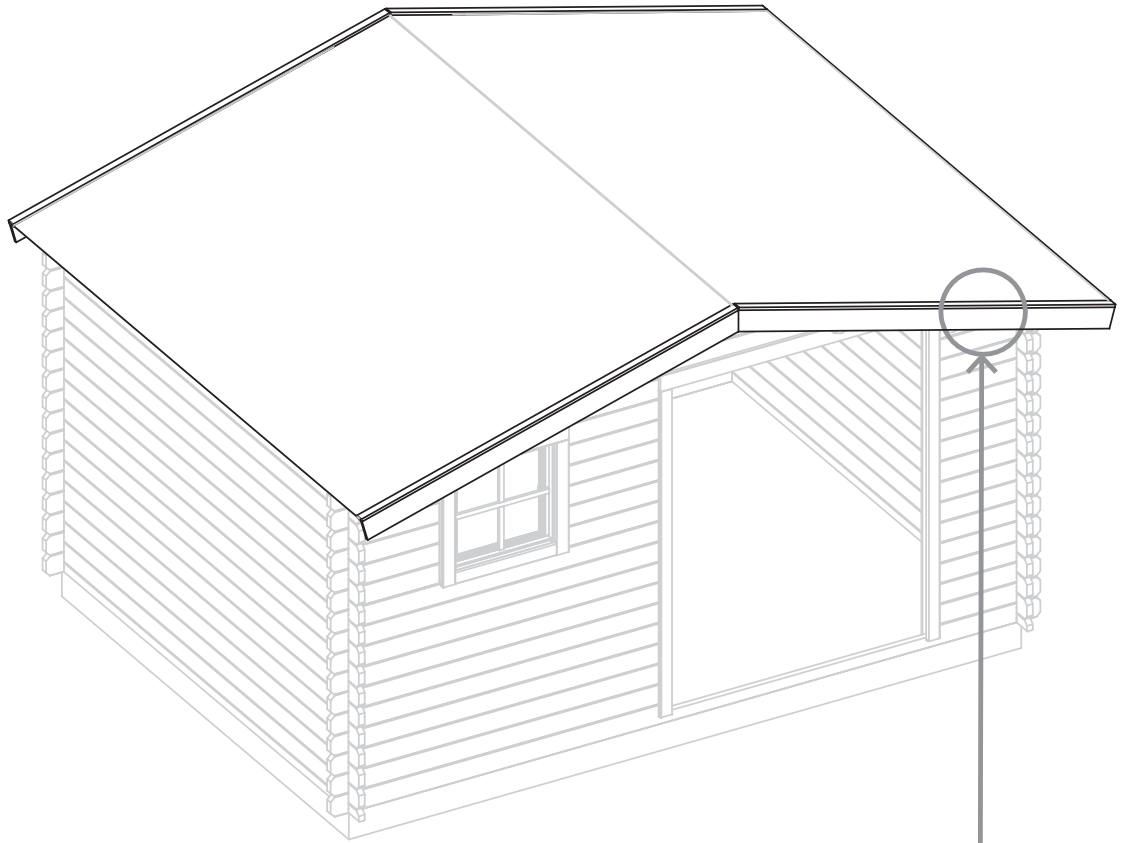

16



[TUK.2.034.SVP.MMXT34]
x 1

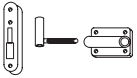

[BH] x 4



[HS11] x 16



[HS12] x 12

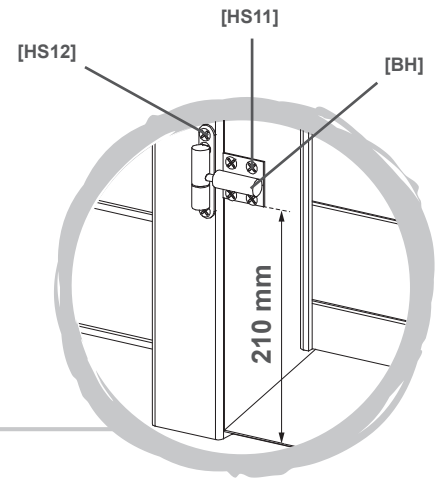
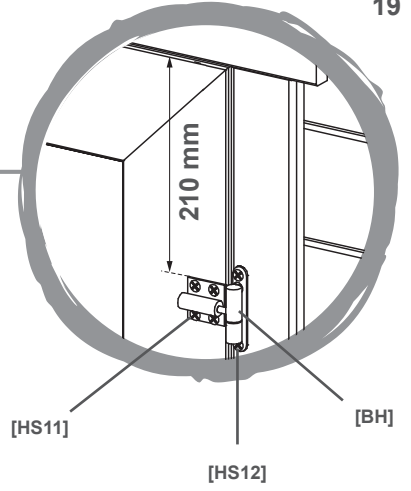
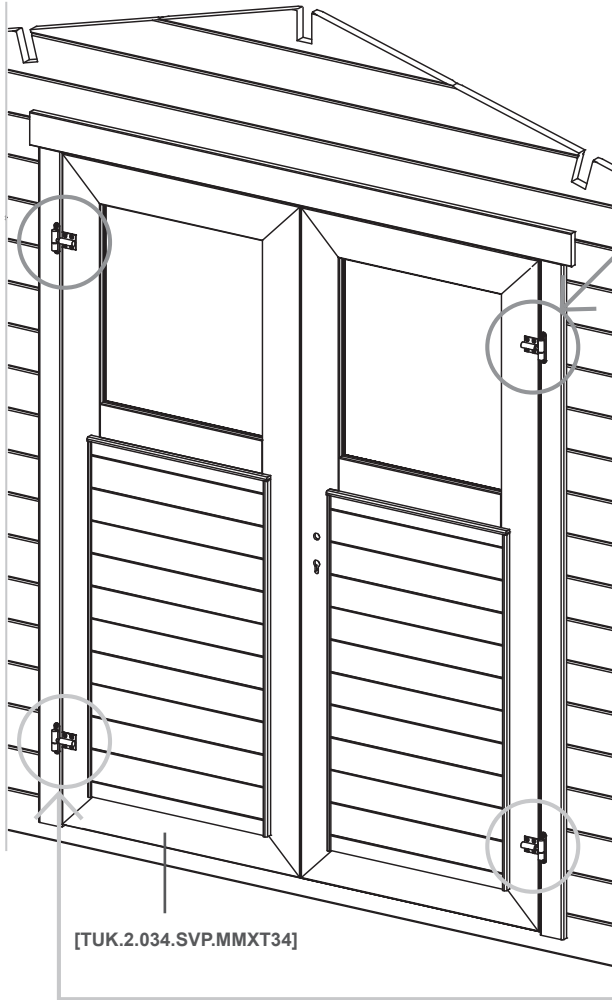

17



[5] x 1



[6] x 2



[7] x 2



[HS1] x 8



[HS4] x 5

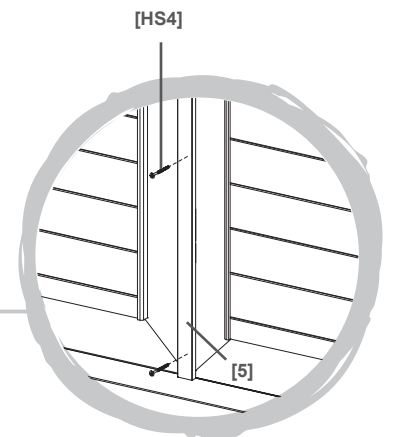
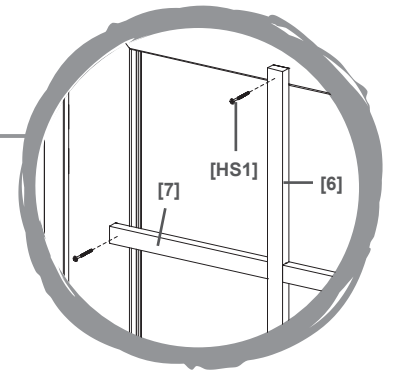
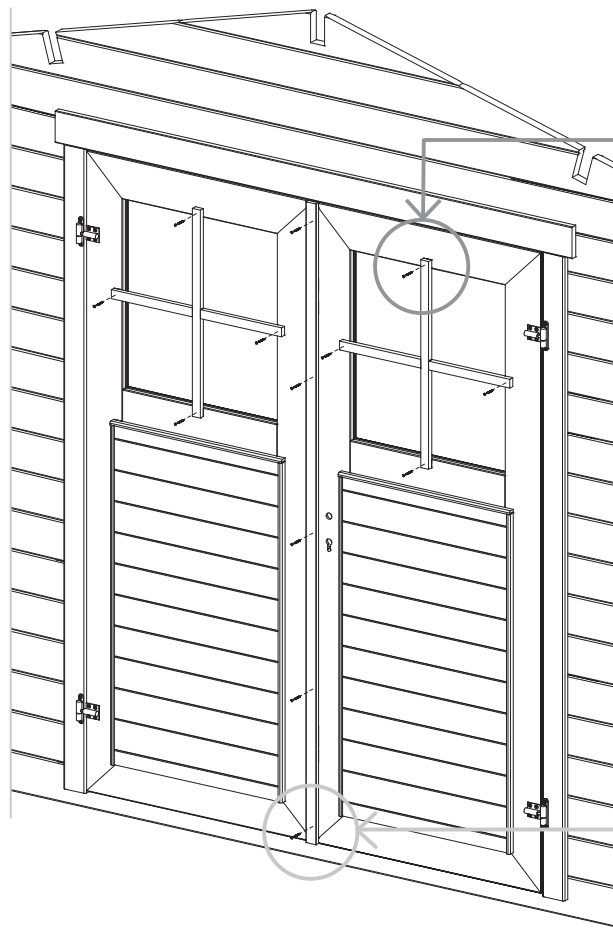

18

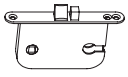

[DL] x 1



[TL4] x 1



[TL5] x 2

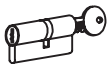

[CL] x 1



[SFL] x 1



[HS10] x 4

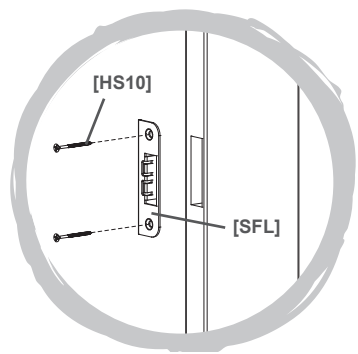
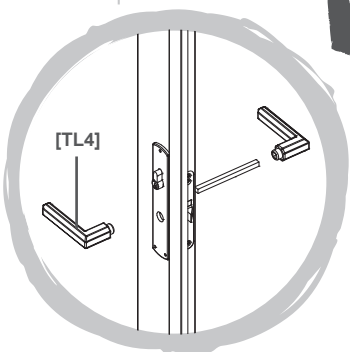
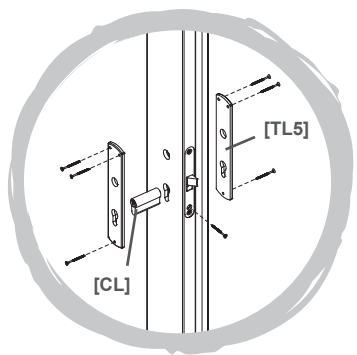
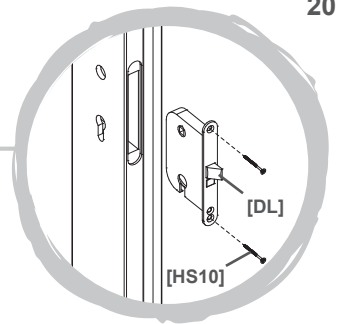
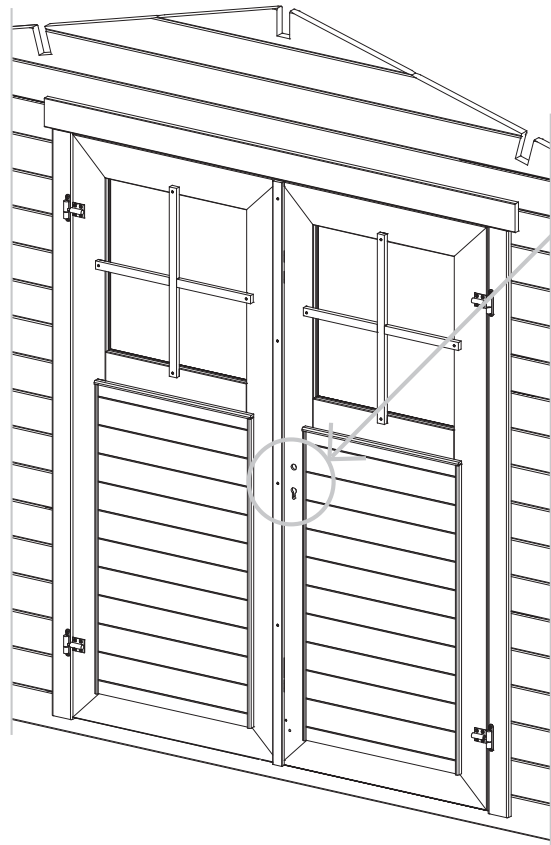

19

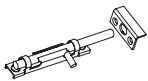

[TL] x 2

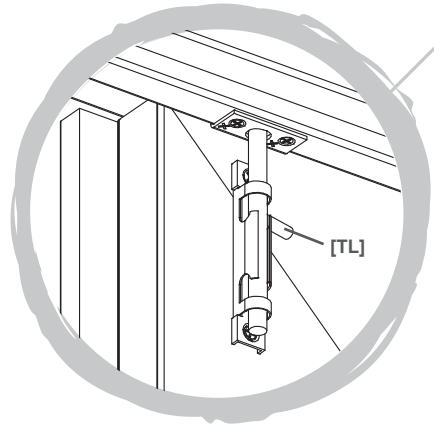



EN Care
PL Pielęgnacja

FR Entretien
RO Îngrijire

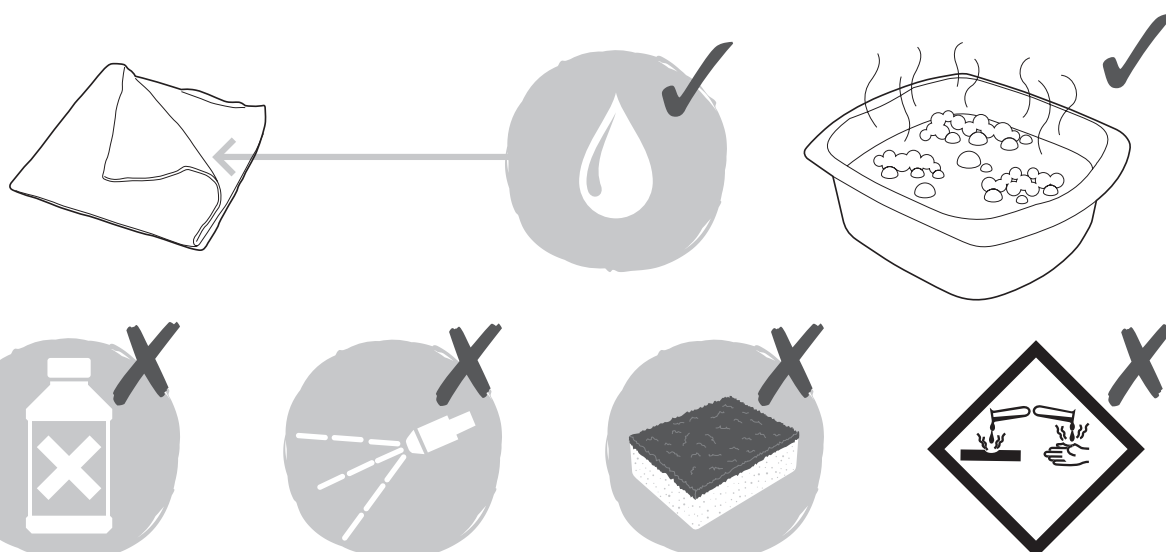
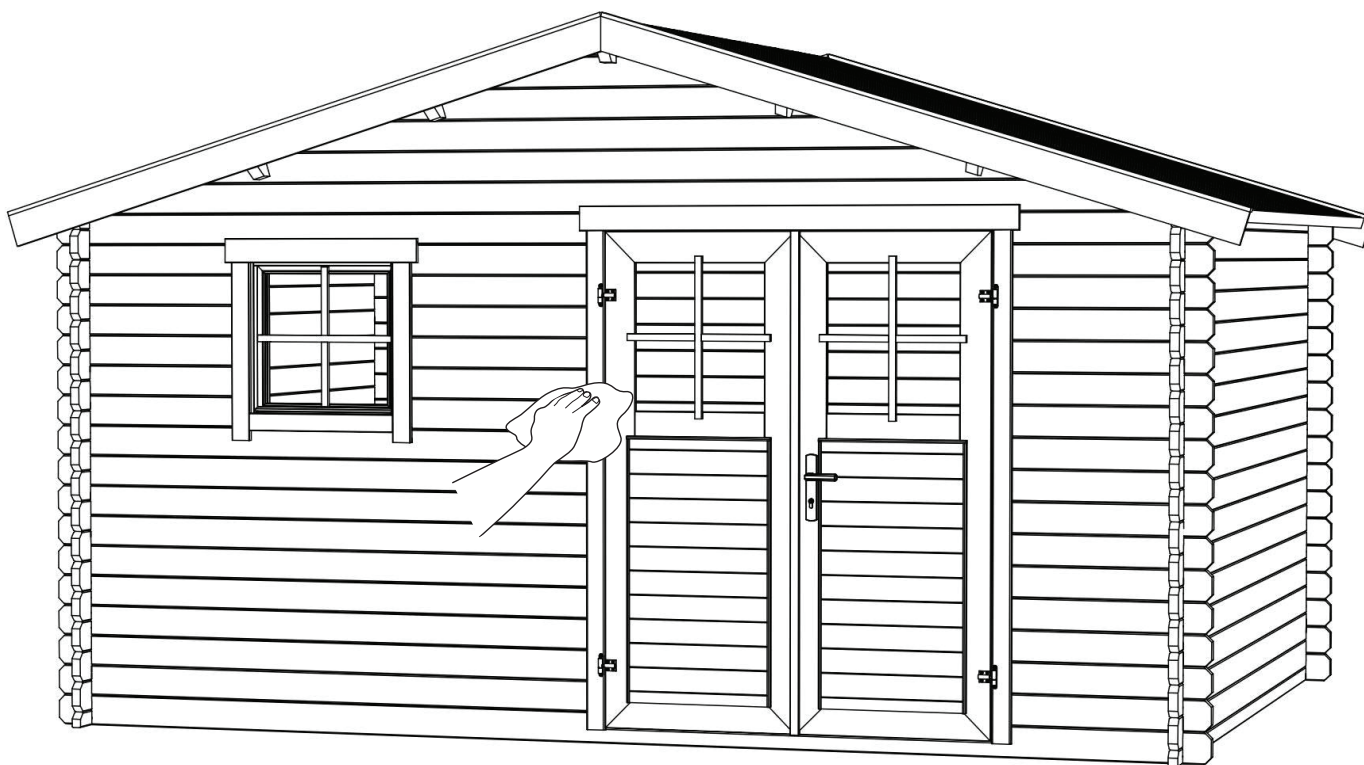



EN Maintenance

PL Konserwacja

FR Maintenance

RO Întreținere

Maintenance

- We recommend removing snow from the roof after each snowfall. Snow more than 10 cm thick can be dangerous!
- Regularly check that all parts are correctly in place.
- Regularly check that the roof material is in good condition.
- Regularly check the condition of your product, and perform any repairs required. Especially check the structure of the roof, the covering, the door and lower parts of the frame, the ends of the wooden baulks and other parts exposed to significant wear.
- Check the operation of doors and windows. Also check the condition of the silicone seals, doors and windows and replace them, if necessary.
- Do not lean on the roof.
- Check and tighten all bolts, screws etc. at the beginning and end of the season because if your shelter dries out in summer, and swells in winter, gaps may appear between some pieces of wood.
- Even with treatment, moisture may enter through corners, knots, crevices and joins between parts. If necessary, apply silicone.

Wood treatment (for raw sheds)

- The wood used has had no protective treatment. This is why it is recommended that you treat your garden shed immediately after construction using a protective anti-sapstain and anti foaming stain. Two layers of protective treatment or paint must be applied after building your shed. Regularly check the condition of the wood and treat again, if necessary. Follow the manufacturer's treatment instructions.
- A better result will be achieved under dry conditions and when the temperature is above +5°C. Doors and windows must be treated on both sides. The shed must also be treated inside using a protective anti-sapstain and anti foaming stain, particularly in the corners. Interior and exterior treatments must be regularly repeated as per manufacturer instructions. Carefully monitor the state of the side wall facing South because it will get more sun.
- Note that the treatment product may flow through from the other side of split knots and leave traces.
- The ends of the wooden baulks and fascia boards are the areas where water is likely to enter. Treat these places with particular care and often because they are the parts most exposed to the weather. Similarly, other surfaces exposed to the weather and often used (fascia boards, roof strips, handrails) must be treated at least once a year.
- The floor must be treated at the same time as the walls. Before the shed is used, the floor must also be treated with, for example, varnish or paint.

Maintenance

- Nous recommandons d'enlever la neige du toit après chaque enneigement. Une épaisseur de neige de plus de 10 cm peut devenir dangereux!
- Vérifiez régulièrement que toutes les pièces sont correctement en place.
- Vérifiez régulièrement que le matériau de toiture est en bon état.
- Vérifiez régulièrement l'état de votre produit et effectuez les réparations éventuelles. Contrôlez tout particulièrement la structure du toit, le matériel de couverture, la porte et les parties inférieures des cadres des menuiseries, les extrémités des madriers et les autres pièces exposées à une usure importante.
- Vérifiez le fonctionnement des portes et fenêtres. Vérifiez aussi l'état des joints en silicone, des portes et des fenêtres et remplacez-les si nécessaire.
- Ne pas monter sur le toit.
- En début et en fin de saison: tous les boulons, les vis, etc doivent être vérifiés et serrés normalement.
- Malgré le traitement, l'humidité peut entrer dans les angles, les nœuds, les fentes et les emboîtements des pièces. Si cela s'avère nécessaire, vous pouvez appliquer du silicone.

Traitement du bois (pour les abris bruts)

- Le bois utilisé n'a subi aucun traitement protecteur. C'est pourquoi il est recommandé de traiter votre abri de jardin tout de suite après le montage avec une lasure protectrice antibleuissement et antimousse. Deux couches de traitement de protection ou de peinture doivent être appliquées juste après avoir monté l'abri. Vérifiez régulièrement l'état du bois et renouvelez le traitement si nécessaire. Suivez les instructions du fabricant du traitement.
- Un meilleur résultat sera obtenu dans des conditions sèches, quand la température est supérieure à +5°C. Les portes et les fenêtres doivent être traitées des deux côtés. L'abri doit être aussi traité à l'intérieur avec une protection anti-bleuissement et antimousse, particulièrement dans les angles des murs. Les traitements intérieurs et extérieurs doivent être répétés régulièrement selon les instructions du fabricant du produit. Surveillez soigneusement l'état du mur positionné côté sud, car l'ensoleillement est plus importants de ce côté.
- Veuillez noter que le produit de traitement peut couler de l'autre côté des nœuds fendus et risque de laisser des traces.
- Les extrémités des madriers et des planches de rives sont des zones susceptibles d'être infiltrées par l'eau. Traitez ces endroits avec un soin particulier et souvent, car ce sont les parties les plus exposées aux intempéries. De la même manière, les autres surfaces exposées aux conditions climatiques et à une utilisation importante (les planches de rive, les baguettes du toit, les mains courantes) doivent être traitées au moins une fois par an.
- Le plancher doit être traité en même temps que les murs. Le plancher doit aussi être traité avant l'utilisation d'abri, avec par exemple, un vitricateur ou de la peinture.

Konserwacja

- Zalecamy usunięcie śniegu z dachu po każdorazowych opadach. Warstwa śniegu o grubości powyżej 10 cm może stwarzać zagrożenie!
- Należy regularnie sprawdzać, czy poszczególne części są na swoim miejscu.
- Należy regularnie sprawdzać, czy pokrycie dachu jest w dobrym stanie.
- Należy regularnie sprawdzać stan produktu i dokonywać niezbędnych napraw. Należy zwrócić szczególną uwagę na konstrukcję dachu, pokrycie, drzwi i dolne partie ościeżnic, końcówki drewnianych belek i inne części narażone na zużycie.
- Sprawdzać działanie drzwi i okien. Należy sprawdzać również silikonowe uszczelki, drzwi oraz okna i w razie potrzeby wymienić je.
- Nie wywierać nacisku na dach.
- Sprawdzić i dokręcić wszystkie śruby, wkręty itp. na początku i końcu każdego sezonu. Jeśli elementy drewniane domku wysuszą się latem i napuchną zimą, mogą pojawić się szczeliny pomiędzy niektórymi kawałkami drewna.
- Nawet po zaimpregnowaniu wilgoć może przedostać się do narożników, sęków, szczelin i łączeń między elementami. W razie potrzeby zastosować silikon.

Obróbka drewna (do surowych szop)

- Drewno nie jest zaimpregnowane. W związku z tym zaleca się zaimpregnowanie domku ogrodowego natychmiast po jego zbudowaniu za pomocą preparatu zabezpieczającego w celu ochrony przed owadami i grzybami niszczącymi drewno. Natychmiast po zakończeniu montażu domku ogrodowego należy pomalować go dwiema warstwami środka impregnującego lub farby. Regularnie sprawdzać stan drewna i w razie potrzeby impregnować je ponownie. Postępować zgodnie z instrukcjami producenta dotyczącymi impregnacji.
- Najlepszy rezultat można uzyskać w suchych warunkach, gdy temperatura wynosi ponad +5°C. Drzwi i okna należy zaimpregnować po obu stronach. Domek ogrodowy należy również zaimpregnować wewnątrz za pomocą odpowiedniego środka w celu ochrony przed owadami i grzybami niszczącymi drewno, zwłaszcza w narożnikach. Impregnację domku wewnątrz i na zewnątrz należy powtarzać zgodnie z zaleceniami producenta. Obserwować stan bocznej ściany od południowej strony, ponieważ będzie do niej docierać więcej słońca.
- Należy pamiętać, że środek impregnujący może przeniknąć z drugiego końca wiązań, łączeń i pozostawić ślady.
- Końcówki drewnianych belek i deski czołowe to obszary podatne na przedostawanie się wody. Należy zaimpregnować te miejsca ze szczególną starannością, ponieważ są one najbardziej narażone na działanie warunków atmosferycznych. Inne miejsca, które są narażone na działanie warunków atmosferycznych i często użytkowane (deski czołowe, pasy papy dachowej, poręcze) należy impregnować co najmniej raz w roku.
- Podłogę należy impregnować w tym samym czasie co ściany. Przed rozpoczęciem korzystania z domku ogrodowego należy zaimpregnować podłogę, np. za pomocą lakieru lub farby.

Întreținere

- Vă recomandăm să îndepărtați zăpada de pe acoperiș după fiecare ninsoare. Un strat de zăpadă mai gros de 10 cm poate fi periculos!
- Verificați în mod regulat dacă toate componentele sunt poziționate corect.
- Verificați în mod regulat dacă materialul acoperișului este în stare bună.
- Verificați în mod regulat starea produsului dvs. și realizați reparațiile necesare. Verificați în mod special structura acoperișului, învelișul, ușa și părțile inferioare ale cadrului, capetele grinzilor longitudinale din lemn și alte părți expuse la uzură semnificativă.
- Verificați funcționalitatea ușilor și a ferestrelor. De asemenea, verificați starea etanșării cu silicon, ușile și ferestrele și, dacă este necesar, înlocuiți-le.
- Nu vă sprijiniți de acoperiș.
- Verificați și strângeți toate bolțurile, șuruburile etc. la începutul și la sfârșitul sezonului deoarece, dacă adăpostul se usucă în timpul verii și se umflă în timpul iernii, pot apărea goluri între anumite bucăți de lemn.
- Chiar și cu tratament, este posibil ca umezeala să pătrundă prin colțuri, noduri, crăpături și îmbinări dintre componente. Dacă este necesar, aplicați silicon.

Tratarea lemnului (pentru hale brute)

- Lemnul utilizat nu a fost supus la tratamente de protecție. De aceea, se recomandă să tratați magazia de grădină imediat după construcție utilizând bai de protecție antifungic și bai antispumă. Aplicați două straturi de material de protecție sau de vopsea după construirea magaziei. Verificați în mod regulat starea lemnului și reaplicați tratamentul, dacă este necesar. Urmați instrucțiunile de tratare ale producătorului.
- Veți obține un rezultat mai bun în condiții uscate și la o temperatură de peste +5°C. Ușile și ferestrele trebuie tratate pe ambele părți. Magazia trebuie tratată, de asemenea, la interior, utilizând bai de protecție antifungic și bai antispumă, în special la colțuri. Tratamente interioare și exterioare trebuie repetate periodic, conform instrucțiunilor producătorului. Monitorizați cu atenție starea peretelui lateral orientat spre sud, deoarece va fi mai expus la soare.
- Rețineți că produsul pentru tratament se poate scurge din partea opusă a nodurilor despicate din lemn și poate lăsa urme.
- Capetele grinzilor longitudinale și ale panourilor compozite sunt zonele în care există riscul de pătrundere a apei. Tratați aceste locuri cu atenție specială și frecvent, deoarece sunt părțile cele mai expuse la intemperii. În mod similar, trebuie să tratați cel puțin o dată pe an alte suprafețe expuse intemperiilor și utilizate frecvent (panourile compozite, benzile pentru acoperiș, balustradele).
- Tratați pardoseala în același timp cu pereții. Înainte de utilizarea magaziei, trebuie să tratați, de asemenea, pardoseala, de exemplu, cu lac sau cu vopsea.