

Silent Fan

Installation and Wiring Instructions



Fixed Speed Models

Stock Ref. No

446658B	- VASF100B
446659B	- VASF100T
477436B	- VASF100HT

Lo-Carbon Models

Stock Ref. N°

479085	- VASF100BV
479086	- VASF100TV
479087	- VASF100HTV
479088	- VASF100TC
479089	- VASF100HTC

Vent-Axia[®]

PLEASE READ INSTRUCTIONS IN CONJUNCTION WITH ILLUSTRATIONS.
PLEASE SAVE THESE INSTRUCTIONS.

IPX5



Installation and Wiring Instructions for the Silent Range Extractor Fans.



IMPORTANT: READ THESE INSTRUCTIONS BEFORE COMMENCING THE INSTALLATION

DO NOT install this product in areas where the following may be present or occur:

- Excessive oil or a grease laden atmosphere.
- Corrosive or flammable gases, liquids or vapours.
- Ambient temperatures higher than 40°C or less than -5°C.
- Possible obstructions which would hinder the access or removal of the Fan.

SAFETY AND GUIDANCE NOTES

- A.** All wiring to be in accordance with the current I.E.T. Regulations, or the appropriate standards of your country and **MUST** be installed by a suitably qualified person.
- B.** The Fan is suitable for installation within Zones 1 & 2.
- C.** The Fan should be provided with a local isolator switch capable of disconnecting all poles, having a contact separation of at least 3mm.
- D.** Ensure that the mains supply (Voltage, Frequency, and Phase) complies with the rating label.
- E.** The Fan should only be used in conjunction with the appropriate Vent-Axia products.
- F.** The Fan should only be used in conjunction with fixed wiring.
- G.** When the Fan is used to remove air from a room containing a fuel-burning appliance, ensure that the air replacement is adequate for both the fan and the fuel-burning appliance.
- H.** The Fan should not be used where it is liable to be subject to direct water spray for prolonged periods of time.
- I.** Where ducted Fans are used to handle moisture-laden air, a condensation trap should be fitted. Horizontal ducts should be arranged to slope slightly downwards away from the Fan.
- J.** This appliance is not intended for use by persons (including children) with reduced physical, sensory or mental capabilities, or lack of experience and knowledge, unless they have been given supervision or instruction concerning use of the appliance by a person responsible for their safety.
- K.** Children should be supervised to ensure that they do not play with the appliance.

- L.** Stationary appliances not fitted with means for disconnection from the supply mains having a contact separation in all poles that provide full disconnection under over voltage category III, the instructions state that means for disconnection must be incorporated in the fixed wiring in accordance with the wiring rules.
- M.** Ensure the grille is fully engaged onto the fan chassis using all clips.

ACCESSORIES (not supplied)

WALL FITTING KIT

A range of 100mm wall kits are available for installing into most walls using telescopic liners supplied.

WINDOW FITTING KIT

For use in single or sealed double glazing and most materials up to 40mm thick.

		Stock Reference	
		White	Brown
Wall Fitting Kit	100mm	254102	254100
Window Fitting Kit	100mm	442947	-

INSTALLATION



IMPORTANT: The fan should only be used in conjunction with fixed wiring.

PANEL MOUNTING

1. For panel mounting the fan should be installed into a closed duct protected by an exterior air grille that must comply with the standard requirements of your country to prevent access to the fans impeller.
2. Cut a 105mm diameter hole for 100mm fans.
3. Push the two clips on the bottom of the fan and pull the grille away from the chassis.
4. Using the built in spirit level bubble as an aid. Mark the screw centres through the holes in the fan back plate. Drill, plug and screw into position.
5. After installation, ensure impeller rotates freely and the shutters can open.
6. Replace the grille and ensure the clips reactivate.

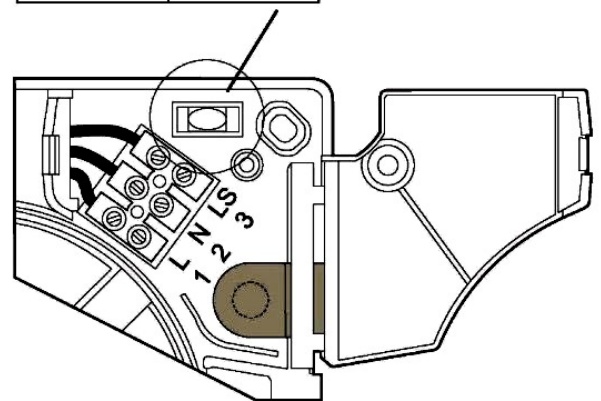
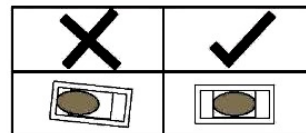

WALL MOUNTING

1. For wall mounting either cut a 115mm diameter hole for 100mm fans, through the wall and insert the wall sleeve. Slope the sleeve slightly downwards away from the fan. Cut to length and cement both ends into position flush with the wall faces.
2. Push the two clips on the bottom of the fan and pull the grille away from the chassis.
3. Using the built in spirit level bubble as an aid. Mark the screw centres through the holes in the fan back plate. Drill, plug and screw into position. Fix exterior grille into position with the louvres positioned downwards. (Note:- The grille must comply with the standard requirements of your country to prevent access to the fans impeller. The wall kit used in this installation should provide a minimum ducting length of 100mm from the fans back plate to the inside of the external grille).
4. After installation, ensure impeller rotates freely and the shutters can open.
5. Replace the grille and ensure the clips reactivate.



WARNING: THE FAN AND ANCILLARY CONTROL EQUIPMENT MUST BE ISOLATED FROM THE POWER SUPPLY DURING THE INSTALLATION / OR MAINTENANCE.

IMPORTANT

- The fan should only be used in conjunction with fixed wiring.
- The cross - sectional area of supply cord used should be ranged from 0.75-1.5mm².
- Cable entry can only be made from the rear of the fan.
- The extraction fan is suitable for connection to 220-240V 50Hz supply.
- The fan is a class II double insulated product and **MUST NOT** be earthed.

1. Select and follow the appropriate wiring diagram. (Fig. 1 or 2)
2. Check all connections have been made correctly and ensure all terminal connections are securely fastened.
3. Ensure the impeller rotates and is free from obstructions.

SETUP



WARNING: THE FAN AND ANCILLARY CONTROL EQUIPMENT MUST BE ISOLATED FROM THE POWER SUPPLY DURING THE INSTALLATION / OR MAINTENANCE.

Fixed Speed Range – Fig1, 2, 3, 4 & 5

VASF100B – Basic - Remote or light switch operation. 2 Speed options selectable at install.

VASF100T – Timer* - Overrun timer adjustable 5-30min. 2 Speed options selectable at install.

VASF100HT - Humidity Timer* - Humidity controlled with fixed 15min. timer overrun. 2 Speed option selectable at install.

Lo-Carbon Variable Speed Range – Fig1, 2, 3 & 6

VASF100BV – Basic - Remote or light switch operation. Variable speed options selectable at install.

VASF100TV – Timer* - Fixed 15min. timer overrun. Variable speed options selectable at install.

VASF100HTV - Humidity Timer* - Humidity controlled with fixed 15min. timer overrun. Variable speed options selectable at install.

Lo-Carbon Continuous Running Range – Fig1, 2, 3 & 6

VASF100TC – Timer* - Fixed 15min. overrun timer. Continuous running fan with variable speed options.

VASF100HTC - Humidity Timer* - Humidity controlled with fixed 15min. timer overrun. Continuous running fan with variable speed options.

***All timer versions require a third switch live wire for the timer to work.**



WARNING: THE FAN AND ANCILLARY CONTROL EQUIPMENT MUST BE ISOLATED FROM THE POWER SUPPLY DURING MAINTENANCE.

1. At intervals appropriate to the installation, the fan should be inspected and cleaned to ensure there is no build-up of dirt or other deposits.
2. Wipe the inlets and front face with a damp cloth until clean.

The fan has sealed for life bearings, which do not require lubrication.

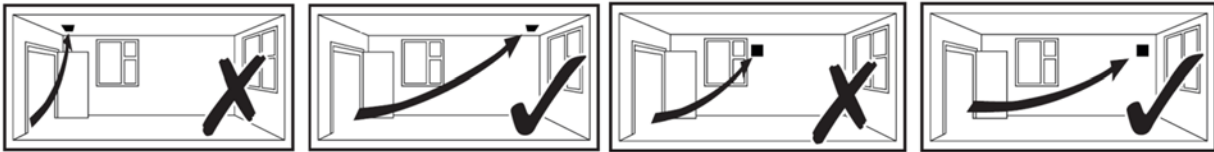

Fig.1: VASF100B, VASF100BV

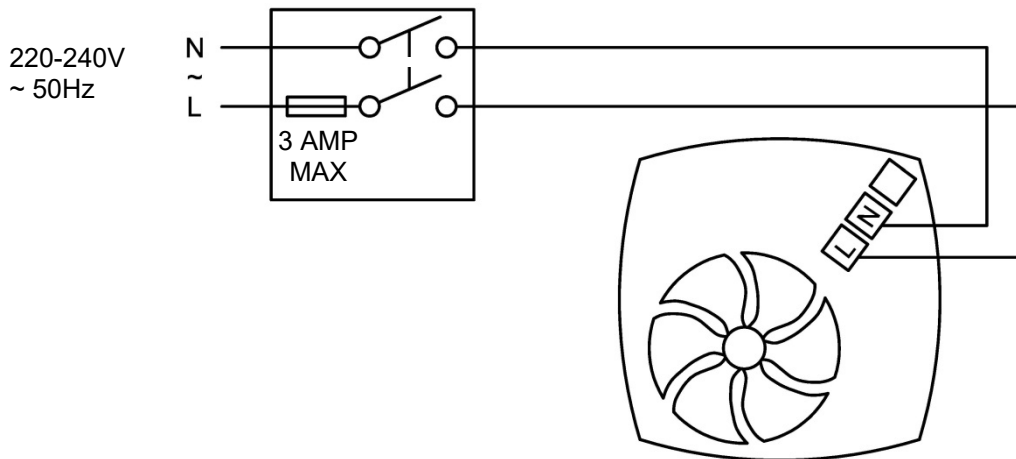

Fig.2: VASF100T, VASF100HT, VASF100TV, VASF100HTV, VASF100TC, VASF100HTC

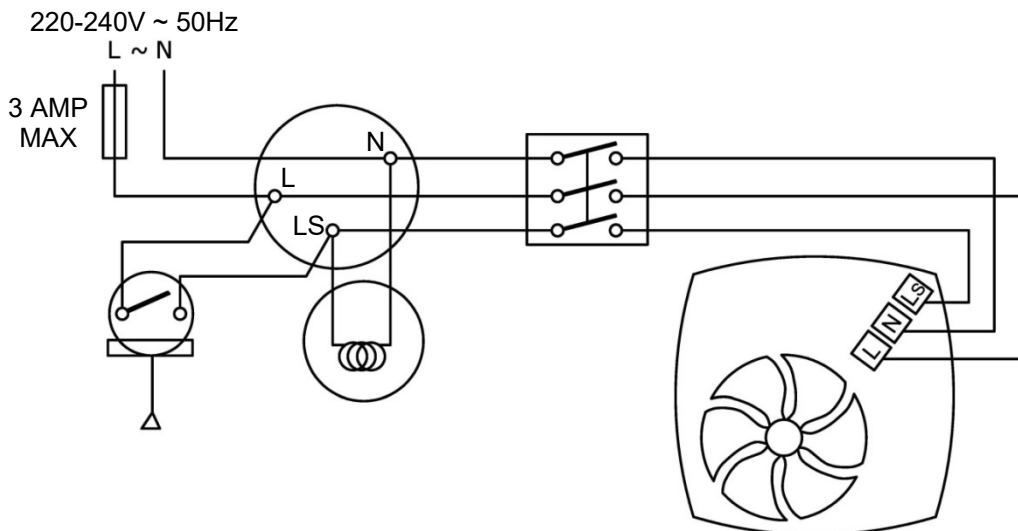

Fig.3: – Grille removal for cable entry and control PCB access.

To remove the inner cover & outer cover, push both clips (1) to release.

To remove the outer cover, slide the cover to the right to release the 4 clips (2), then out towards you (3). To refit the cover, line up the 4 clips on the rear of the cover and slide to the left until you hear a “click”.

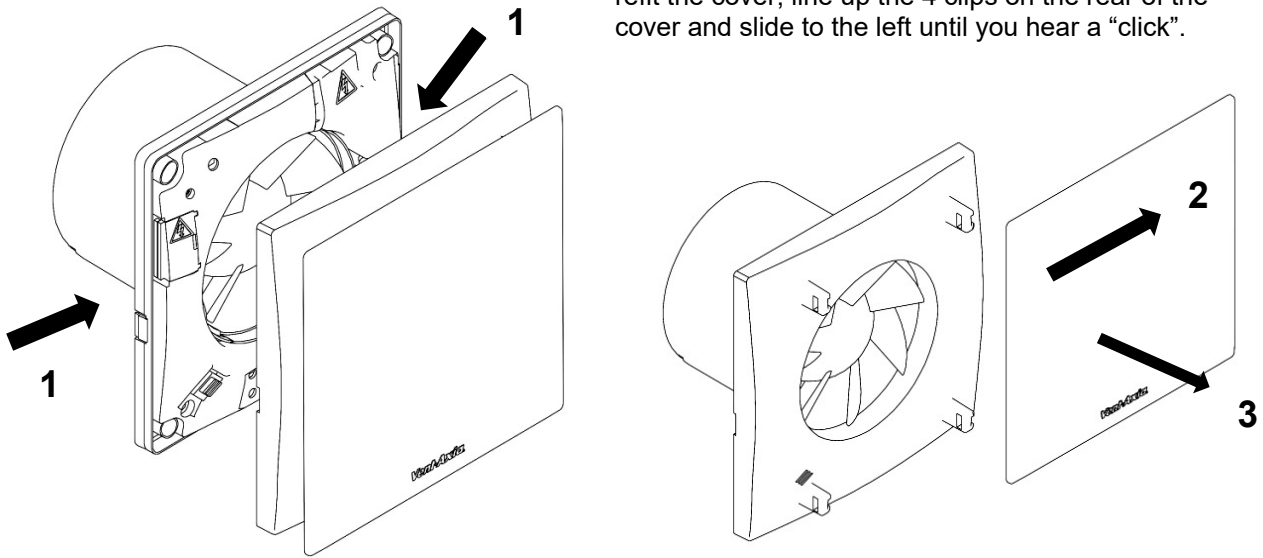
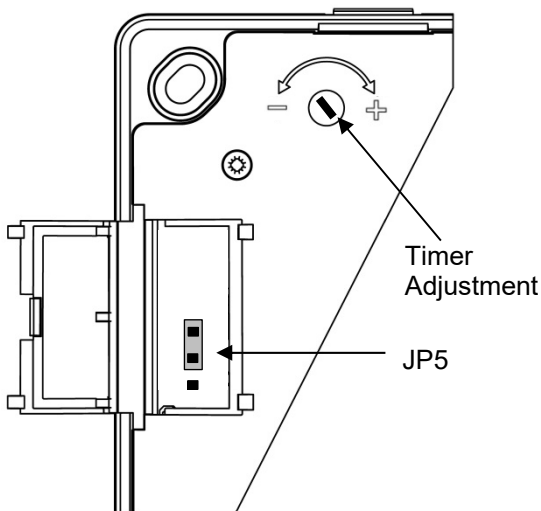

Fig.4: VASF100B , VASF100T



Timer Adjustment:

To **REDUCE** the operating time, use a small screwdriver to turn the adjuster **ANTI-CLOCKWISE**.

To **INCREASE** the operating time, use a small screwdriver to turn the adjuster **CLOCKWISE**.

Speed Selection (JP5):

Change the jumper connector to the position shown for the desired speed

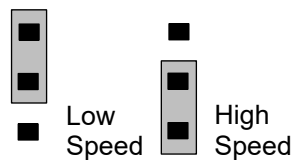
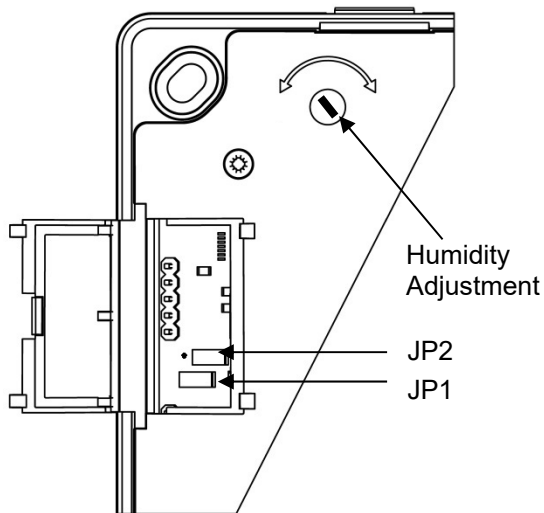

Fig.5: VASF100HT



Humidity Adjustment

To **INCREASE SET POINT**, turn the adjuster **clockwise**. This makes the controller **LESS** sensitive.

To **REDUCE SET POINT**, turn the adjuster **anti-clockwise**. This makes the controller **MORE** sensitive.

Speed selection (JP2).

The fan is factory set to low speed with jumper JP2 fitted. To activate the high speed setting remove jumper JP2.

Timer Function (JP1)

JP1 to deactivate the timer, remove the jumper.
15min. timer = jumper in.
No timer = jumper out.

Fig.6: VASF100BV, VASF100TV, VASF100HTV, VASF100TC, VASF100HTC

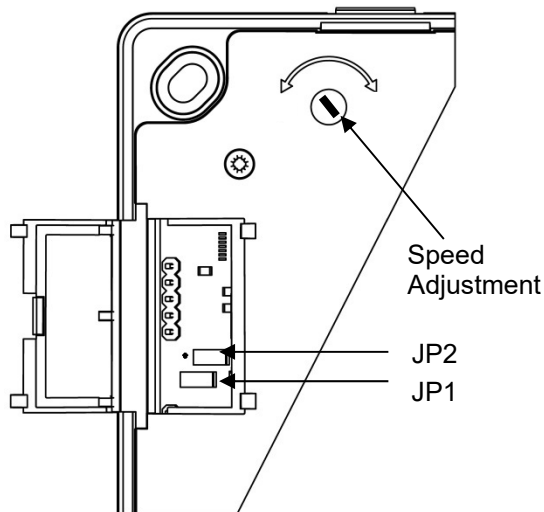

Ambient Response Humidity Function – HTV & HTC only

The inbuilt humidity sensor automatically adjusts dependant on ambient conditions and does not need adjusting.

Speed Selection

Adjust the fan speed by turning the pot clockwise to increase, and anti-clockwise to decrease. For continuous running models, the trickle speed is approximately 50% of the chosen high speed.

Comfort mode (JP2) – TV, HTV, TC & HTC only

JP2 should be connected to enable comfort mode. (default off). This feature delays the LS input boost operation for a maximum of 20 minutes to reduce noise and cold drafts while bathing. After the LS is disconnected, the fan will switch on for the same period the LS had been active (up to 20 minutes), plus the overrun time period if selected (0 or 15 minutes).

Timer Function (JP1) – TV, HTV, TC & HTC only

JP1 to deactivate the timer, remove the jumper.
15min. timer = jumper in.
No timer = jumper out.



Disposal

This product should not be disposed of with household waste. Please recycle where facilities exist. Check with your local authority for recycling advice.

The **Vent-Axia** Guarantee

Applicable only to products installed and used in the United Kingdom. For details of guarantee outside the United Kingdom contact your local supplier.

Vent-Axia guarantees the fixed speed products for 2 years and the Lo-Carbon products for 5 years from date of purchase against faulty material or workmanship. In the event of any part being found to be defective, the product will be repaired, or at the Company's option replaced, without charge, provided that the product:-

- Has been installed and used in accordance with the instructions given with each unit.
- Has not been connected to an unsuitable electricity supply. (The correct electricity supply voltage is shown on the product rating label attached to the unit).
- Has not been subjected to misuse, neglect or damage.
- Has not been modified or repaired by any person not authorised by the company.

IF CLAIMING UNDER TERMS OF GUARANTEE

Please return the complete product, carriage paid to your original supplier or nearest Vent-Axia Centre, by post or personal visit. Please ensure that it is adequately packed and accompanied by a letter clearly marked "Guarantee Claim" stating the nature of the fault and providing evidence of date and source of purchase.

The guarantee is offered to you as an extra benefit, and does not effect your legal rights

Vent-Axia[®]

Head Office: Fleming Way, Crawley, West Sussex, RH10 9YX. Tel: 01293 526062 Fax: 01293 551188

UK NATIONAL CALL CENTRE

SALES ENQUIRIES: Tel: 0344 8560590

Email: sales@vent-axia.com

TECHNICAL SUPPORT: Tel: 0344 8560594

Email: vatechsupport@vent-axia.com

As part of the policy of continuous product improvement Vent-Axia reserves the right to alter specifications without notice.

EU Authorised Representative: Vent-Axia Sigarenmaker 5 - 5521DJ Eersel Nederland authorisedrep@vent-axia.nl