

INSTALLATION & USER INSTRUCTIONS

LED ELECTRIC FIRE



MODELS COVERED BY THESE INSTRUCTIONS

Rivenhall White - DS-EHS01-41E

Rivenhall Black - DS-EHS01-39E

GB IE



Christchurch, Dorset BH23 2BT

Tel: 01202 499330

Fax: 01202 499326

www.focalpointfires.co.uk

Email: sales@focalpointfires.co.uk

Focal Point Fires Ltd.

RBK House, Irishtown, Athlone,
Co. Westmeath, N37 XP52, Ireland

Tel: 01202 499330

Fax: 01202 499326

www.focalpointfires.co.uk

e: sales@focalpointfires.co.uk



MODELS SHOWN: RIVENHALL LED ELECTRIC

This product is only suitable for well insulated spaces or occasional use.

Please note: Except where otherwise stated, all rights, including copyright in the text, images and layout of this booklet is owned by Focal Point Fires Ltd. You are not permitted to copy or adapt any of the content without the prior written permission of Focal Point Fires Ltd.

3 YEAR GUARANTEE

SUBJECT TO TERMS & CONDITIONS

For details please see: www.focalpointfires.co.uk or telephone
01202 588635 Option 4

All instructions must be handed to the user for safekeeping.

Revision A-07/21

Section	Contents	Page No.	Section	Contents	Page No.
1.0	Important Notes	2	9.0	Operating the Appliance	6
2.0	Installation Requirements	3	10.0	Safety Cutout System	7
3.0	Appliance Data	3	11.0	Cleaning and Maintenance	8
4.0	Component Checklist	4	12.0	Replace The Led Strip	8
5.0	Site Requirements	4	13.0	Troubleshooting Guide	9
6.0	Clearances To Combustibles	5	14.0	Servicing	9
7.0	Unpacking The Appliance	5	15.0	Appliance Dimensions	10
8.0	Installation	5	16.0	Guarantee - Terms and Conditions	10

1.0 IMPORTANT NOTES

IMPORTANT - THESE INSTRUCTIONS SHOULD BE READ CAREFULLY AND RETAINED FOR FUTURE REFERENCE.

When using this electrical appliance, basic precautions should be followed to reduce the risk of fire, electric shock and injury to person, including the following:

- This heater must be used on an AC supply only and the voltage marked on the heater's rating label must correspond to the supply voltage.
- **DO NOT** switch the appliance on until it is properly installed as described in this manual.
- This appliance can be used by children aged from 8 years and above and persons with reduced physical, sensory or mental capabilities or lack of experience and knowledge if they have been given supervision or instruction concerning use of the appliance in a safe way and understand the hazards involved. Children shall not play with the appliance. Cleaning and user maintenance shall not be made by children without supervision.
- Children of less than 3 years should be kept away unless continuously supervised. Children aged from 3 years and less than 8 years shall only switch on/off the appliance provided that it has been placed or installed in its intended normal operating position and they have been given supervision or instruction concerning use of the appliance in a safe way and understand the hazards involved. Children aged from 3 years and less than 8 years shall not plug in, regulate and clean the appliance or perform user maintenance.
- **CAUTION:** Some parts of this product can become very hot and cause burns. Particular attention has to be given where children and vulnerable people are present.
- If the supply cord is damaged, it must be replaced by the manufacturer, its service agent or similarly qualified persons in order to avoid a hazard.
- The heater must not be located immediately below a socket-outlet.
- **DO NOT** use this heater in the immediate surroundings of a bath, a shower or a swimming pool.



- **WARNING:** In order to avoid overheating, do not cover the heater.
- **DO NOT** use this heater with a programmer, timer, separate remote-control system or any other device that switches the heater on automatically, since a fire risk exists if the heater is covered or positioned incorrectly.
- **CAUTION:** In order to avoid a hazard due to inadvertent resetting of the thermal cutout, this appliance must not be supplied through an external switching device, such as a timer, or connected to a circuit that is regularly switched on and off by the utility.
- **WARNING:** This heater is not equipped with a device to control the room temperature. Do not use this heater in small rooms when they are occupied by persons not capable of leaving the room on their own, unless constant supervision is provided.
- Keep furniture, curtains and other fabric material away from the appliance.
- **DO NOT** leave the appliance unattended during use.

- From time to time, check the cord for damage. Never use the appliance if the cord or any part of the appliance shows signs of damage.
- **DO NOT** run the mains cable under carpets, rugs etc.
- **DO NOT** cover or obstruct the heater in any way. Overheating will result if it is accidentally covered.
- Never immerse the product in water or any other liquids.
- **DO NOT** use the appliance outdoors.
- Before cleaning the appliance, ensure it is unplugged from the power and that it is completely cool.
- **DO NOT** clean the appliance with abrasive chemicals.
- Never use accessories that are not recommended or supplied by the manufacturer. It could cause danger to the user or damage to the appliance.
- **DO NOT** insert or allow foreign objects to enter the inlet or outlet vents as this may result in electric shock, fire or damage to the appliance.
- **DO NOT** install the fire using an extension cord.
- Unplug from the mains supply if the appliance is not to be used for long periods.
- This product is only suitable for well insulated spaces or occasional use.

2.0 INSTALLATION REQUIREMENTS

The appliance is supplied with a pre-wired, three pin BS plug (13 Amp fuse rated) and 1.80 metres of electrical cable. It is therefore necessary for a suitable electrical socket to be located within this distance and be easily accessible. This appliance is designed to be fixed to the wall, using the wall fixtures/fixings provided. DO NOT recess any part of appliance into the wall. This appliance is suitable for installation in static holiday/park homes.

3.0 APPLIANCE DATA

Weight (kg):	22.4 kg
Dimensions:	H600x W1000 x D265(mm)
Supply Voltage and Rating Power:	220-240V AC, 50Hz 2000W
Fuse Rating:	13 Amp
Heating Elements:	2000W
Lighting:	LED

This fire is fitted with LED's (Light Emitting Diode) in place of conventional bulbs. LED's generate the same light levels as conventional bulbs, but use a fraction of the energy consumed. LED's are maintenance free and should not require replacing during the life of the product.

Model		RIVENHALL WHITE - DS-EHS01-41E RIVENHALL BLACK - DS-EHS01-39E			
Item	Symbol	Value	Unit	Item	Unit
Heat output				Types of heat input, for electric storage local space heaters only	
Nominal heat output	P_{nom}	2.0	KW	Manual heat charge control with integrated thermostat	No
Minimum heat output (indicative)	P_{min}	1.0	KW	Manual heat charge control with room and/or outdoor temperature feedback	No
Maximum continuous heat output	$P_{max, c}$	2.0	KW	Electronic heat charge control with room and/or outdoor temperature feedback	Yes

3.0 APPLIANCE DATA - CONTINUED



Auxiliary electricity consumption				Fan assisted heat output	N/A
At nominal heat output	<i>elmax</i>	2.05	KW	Type of heat output/room temperature control	
At minimum heat output	<i>elmin</i>	1.05	KW	Single stage heat output and no room temperature control	No
In standby mode	<i>elSB</i>	N/A	KW	Two or more manual stages no temperature control	No
				With mechanical thermostat room temperature control	No
				With electronic room temperature control	Yes
				Electronic room temperature control plus day timer	Yes
				Electronic room temperature control plus week timer	Yes
				Other control options	
				Room temperature control with presence detection	Yes
				Room temperature control with open window detection	Yes
				With distance control option	Yes
				With adaptive start control	Yes
				With working time limitation	No
				With black bulb sensor	No
Contact details	Focal Point Fires, Avon Trading Park, Christchurch, Dorset, BH23 2BT				

4.0 COMPONENT CHECKLIST

Quantity	Description
1	Heater unit
3	Fixing brackets
7	Wall fixing screw
7	Wall plugs
2	Firebox screws

5.0 SITE REQUIREMENTS

It should be noted that the appliance creates warm convected air currents. These currents move heat from the room surroundings to, and up the wall surfaces adjacent to the heater.

Installing the heater next to these types of wall coverings or operating the heater where impurities in the air, (such as tobacco smoke) exist, may slightly discolour wall finishing.

If the appliance is to be secure on a dry lined or timber framed construction then the integrity and ability of the wall to secure the appliance must be confirmed. It is important in these circumstances that any vapour barrier and or structural members of the house frame are not damaged.

If you are unsure of the ability of the wall to secure the appliance and or which type of wall fixing to use, you should take professional advice and obtain the correct fixings. Alternatively, find a more suitable wall location.

DO NOT

- Recess any part of the appliance into the wall, or run the supply cable under carpets
- Site in a position where curtains or drapes could cover the appliance, or other soft materials could cover e.g. below a coat rack
- Site behind an opening door where mechanical impact/damage could occur
- Site where the supply cable would become a trip hazard
- Sit, stand or forcefully pull on the appliance
- Obstruct, cover or force items into the openings

5.0 SITE REQUIREMENTS - CONTINUED

GB IE

- use the heater to dry clothes
- site/use in an outdoor location(s)

It is important that the following clearances are maintained from the appliance to combustible materials. These clearances are dependent on the securing location as defined below:

6.0 CLEARANCES TO COMBUSTIBLES

- The minimum distance to the front of the appliance is 900mm.
- There are no clearances for above or to the side of the appliance, apart from being clear of curtains and drapes.

7.0 UNPACKING THE APPLIANCE

Caution: This appliance is heavy. Always seek assistance whilst unpacking and/or during installation. Please read all the instructions before continuing to unpack or install appliance.

Before starting the installation of this fireplace, please read the following:

1. The installation should be carried out by two adults to avoid injury or damage. If for any reason it is considered too heavy, please obtain assistance.
2. When lifting the electric suite, always keep your back straight. Bend your legs and not your back. Avoid twisting at the waist. It is better to reposition your feet.
3. Avoid upper body / top heavy bending. Always bend from the knees rather than the waist. Do not lean forward or sideways while handling the heater.
4. Always grip the heater with the palm of the hand. Do not use the tips of fingers for support.
5. Always keep the heater as close to the body as possible. This will minimize the cantilever action.
6. Use gloves to provide additional grip.
7. Unpack the package and lift the product gently out of the box, put it on a flat surface with the front panel facing forward.

IMPORTANT - PLEASE READ COMPLETELY THROUGH THE INSTRUCTIONS AND VERIFY THAT ALL LISTED PARTS ARE PRESENT BEFORE ASSEMBLY.

8.0 INSTALLATION

CAUTION: DO NOT CONNECT THE APPLIANCE TO THE ELECTRICAL SUPPLY AT THIS TIME.

Focal Point Fires Ltd. assumes absolutely no responsibility for injuries and damages that may occur due to improper installation or handling.

Remove any protective film coatings from the finished/decorative surfaces of the appliance, if any. After having selected the final position of the appliance taking into account the integrity of the wall the electric suite may be secured to the wall.

To ensure customer safety, be sure to design the installation so that the strength of both the wall and any wall fixings used are sufficient. The appliance should not be installed until all wet plastering and/or dry wall sanding and wall painting has been completed. Do not block the ventilation holes of the appliance. The wall onto which the appliance is installed must be flat. Install only on a vertical surface. Avoid sloped surfaces. Installation onto anything other than a vertical wall may result in fire, damage or injury.

If the appliance is to be mounted on the inner leaf of a conventional cavity brick wall, or a solid wall, then the wall plugs and fixing screws provided may be used. Depending on the condition of the wall it may be necessary to use additional fixings. In this situation, any additional fixings and wall plugs should be of the same size and type as the ones provided.

If the appliance is to be mounted on a dry lined wall or a timber framed construction wall then efforts should be made to fix one position vertically, into one of the wooden studs, or supporting wooden members of the wall using the fixing screws provided. If this is not achievable then the wall should be strengthened using appropriate building materials.

WARNING

The wall where the appliance is to be installed must be capable of long-term support of the total load of the appliance. Measures should also be taken to ensure sufficient strength to withstand the force of earthquakes, vibration and other external forces. Plasterboard alone is not considered to be a structural material. It is not recommended to rely on plasterboard fixings alone to support the weight of the appliance.



8.0 INSTALLATION - CONTINUED

GB IE

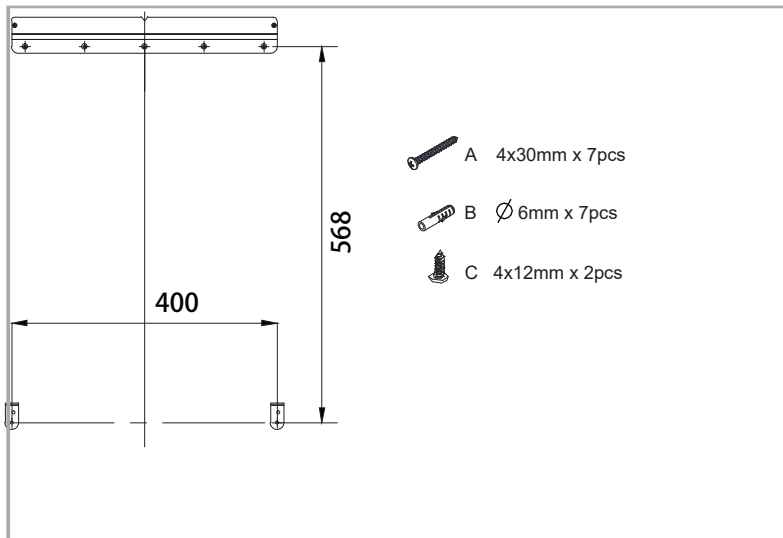

Installing the appliance onto the wall.

Please note: Before drilling into walls, always check that there are no hidden wires, pipes, etc. Make sure that screws and wall plugs supplied are suitable for supporting the unit in your surface. Consult a qualified person if you are not sure.

1. Ensure the wall fixing brackets are level.
2. Mark out the 7 hole locations.
3. Drill 7 holes (6mm diameter, 40mm deep) into the wall.
Please refer to the diagram for hole locations.

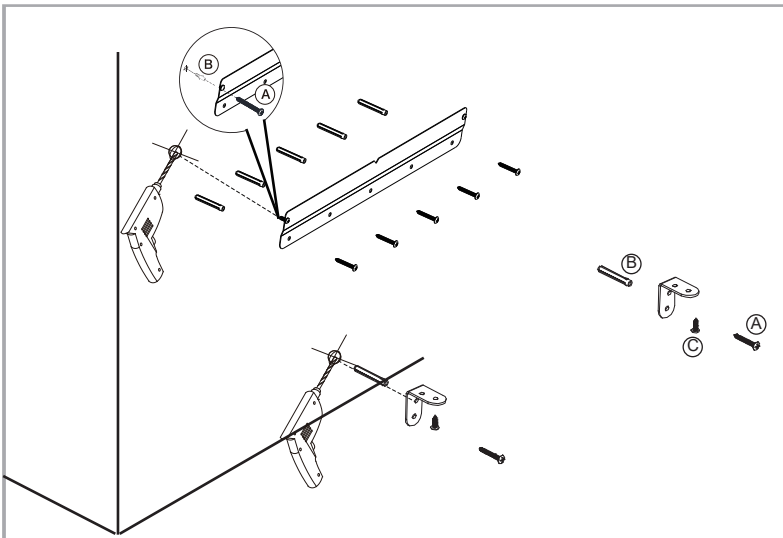

4. Insert the supplied wall plugs (B) into the drilled holes.
5. Offer the brackets into position and screw into place with the wall screws (A) provided.
6. Carefully lift the appliance onto the top bracket.
7. Screw the 2 appliance screws (C) into position underneath the appliance, securing the appliance in place.

9.0 OPERATING THE APPLIANCE

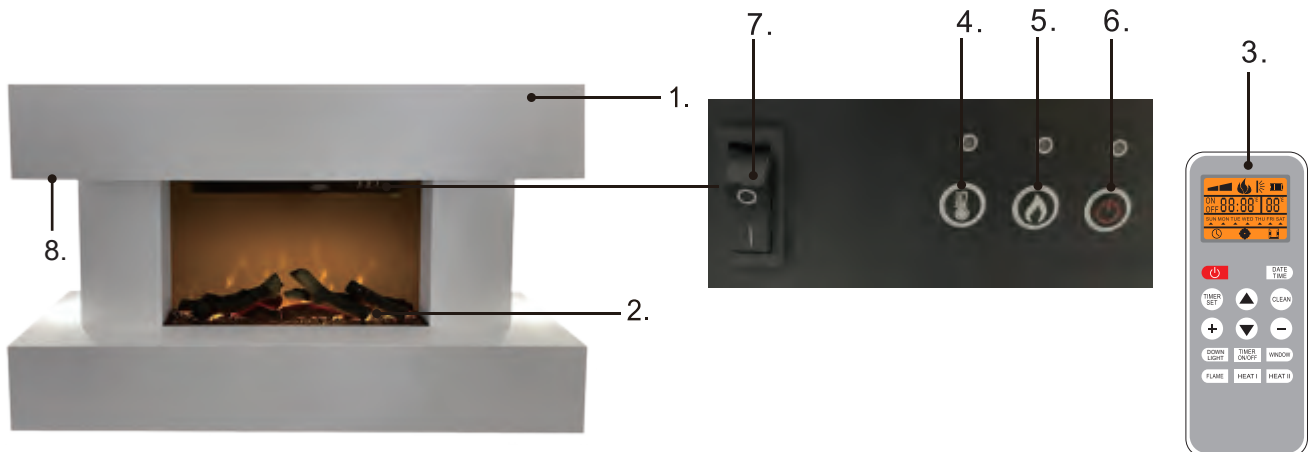

- | | |
|-------------------|-------------------|
| 1. Mantel | 5. Flame effect |
| 2. Logs | 6. Fire ON/OFF |
| 3. Remote control | 7. Power Switch |
| 4. Heat settings | 8. LED Downlights |

NOTE: press button (5) 3 seconds to turn on the downlights function.

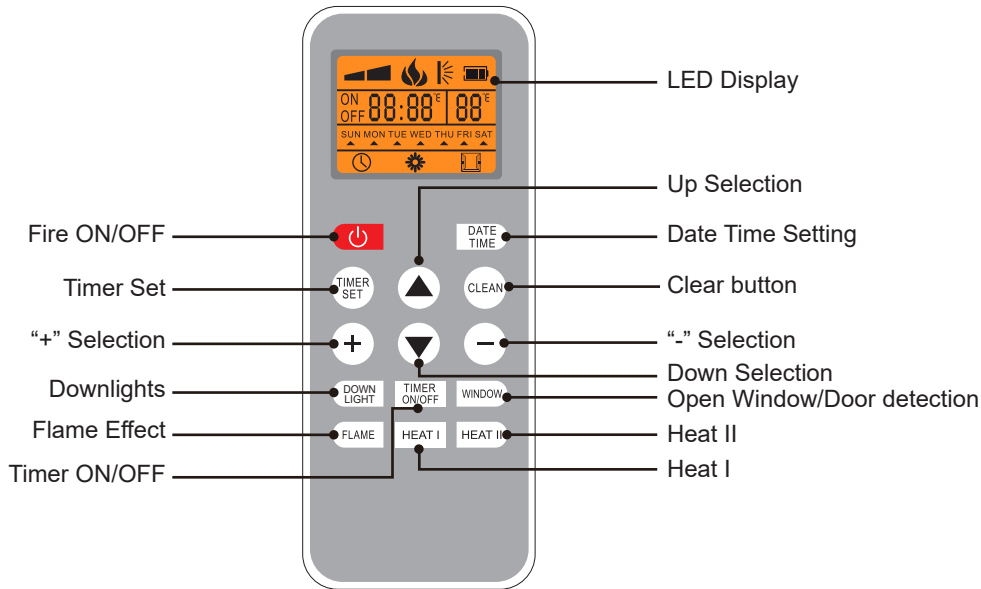

BCH9. Before using any operation with the remote control, Insert 2 x AAA batteries to the back of the remote control. The remote control will not respond until the digital display is illuminated as it is in sleep mode. Before operating, press any button once to illuminate the digital display in order to activate the remote control. Do not press the remote control buttons more than once within two seconds for correct operation. Please wait for the receiver to respond to the transmitter

10.0 OPERATING THE APPLIANCE - CONTINUED

A Ubi U`CdYfUjcb

- GH9D`%** Plug in and turn the mains power supply on.
- GH9D`&** Turn the switch on the right hand side of the heater outlet to **Í Î** position.
- GH9D`.** Press the button to turn on the appliance.
- GH9D`('.** Press the button once to activate the low heat setting, press it again to activate the high setting, press it a third time to switch the heat setting off.
- GH9D`)'.** To change the flame brightness, press the button to cycle through the brightness options. Turn off the LED flame effect by pressing the button repeatedly until the flame effect cycles off.
- BCH9.** press button 3 seconds to turn on the downlights function.
- GH9D`*.** Activate the standby mode by pressing the button again.
- GH9D`+.** Switch the fire off by turning the switch on the right hand side of the heater to the **Í 0 Î** position.

FYa cH`7 cbfc`CdYfUjcb

- GH9D`%** Switch on the appliance using the switch.
- GH9D`&** Press the power button on the remote control; the LCD display will illuminate.
- GH9D`.** Press **Í : 8 A 9 Î** button on the remote control to select the desired flame brightness; there are 3 different brightness levels available.
- GH9D`('.** Select the desired heat output by pressing the relevant heat setting button:
To activate the low heat setting, press **Í < 9 5 H` Î /** press it again to turn it off.
To activate the high heat setting, press **Í < 9 5 H` Î /** press it again to turn it off.

GYHj[b[`h Y`7 i ffYbh8 UmUbXH]a Y

- The day and time can only be set using the remote control.
- GH9D`%** Press the **Í 8 5 H9 H-A 9 Î** button on the remote control, the day of the week will flash, Use the up and down buttons to set the day of the week. Once the current day is set, press the **"8 5 H9 H-A 9"** button to confirm the current day.
- GH9D`&** The hour setting will then flash once the day has been selected. Use **"Z"** or **"!"** to adjust the time until the current hour is selected. Press the **"8 5 H9 H-A 9"** button to confirm the current hour.
- GH9D`.** Then the minute setting will flash once the hour has been set. Use **"Z"** or **"!"** to adjust the time until the current minute is set correctly. Press the **"8 5 H9 H-A 9"** button to confirm the current minute.

Setting the Heat Timer

Press the **"TIMER SET"** button on the remote control, the time cycle number will flash. Use the **"+"** and **"-"** buttons to cycle through the different timer cycles from 1 to 10 and press the **"TIMER SET"** button to confirm. A small black triangle will flash below one day of the week, indicating that the day of the week need to be determined.

Press the **"CLEAR"** button can cancel the set time conveniently.

Selecting the Day

STEP 1: Press the up or down buttons on the remote control to choose the set day between **"SUN"** to **"SAT"**, the default day is **"SUN"**. Press the **"+"** button to confirm the set day. Press the **"TIMER SET"** button to confirm.

STEP 2: Repeat **STEP 1** to add other days to the chosen timer cycle, or press the **"-"** button to delete the set day. Press the **"TIMER SET"** button to confirm.

Set TIMER ON Time

The **"ON"** symbol will illuminate on the LCD display to indicate that the Timer ON will need to be set.

STEP 1: Press the **"+"** or **"-"** button to set the hour setting for Timer ON and press the **"TIMER SET"** button to confirm.

STEP 2 : Press the **"+"** or **"-"** button to set the minute setting for Timer ON and press the **"TIMER SET"** button to confirm.

The **"ON"** symbol with turn off and the **"OFF"** symbol will illuminate.

Set TIMER OFF Time

The **"OFF"** symbol will illuminate on the digital display to indicate that the timer OFF will need to be set.

STEP 1: Press the **"+"** or **"-"** button to set the hour setting for Timer OFF and press the **"TIMER SET"** button to confirm.

STEP 2: Press the **"+"** or **"-"** button to set the minute setting for Timer OFF and press the **"TIMER SET"** button to confirm.

Downlights

Press the **"Downlight"** button to turn on the LED downlights , press again the **"Downlight"** button to turn off the LED downlights.

NOTE: press button 3 seconds to turn on the downlights function.

Open Window/Door detection

When this function is enabled , if the ambient temperature is lowered due to the opening of th doors or windows, indicator light on **"HEAT"** button on the appliance will blink to remind the user to close the window/door. If there is no response, the system will automatically stop heating. The heater can be turned back on by pressing **"HEAT I "** or **"HEAT II"**.

NOTE: Press the window button once to active the window monitor, Press it again to switch the window monitor off.

Safety Cutout System

CAUTION: This product has a self-resetting overheat protection device. In the event that the heater stops working as a result of overheating, the fan kept working all the time, take the following immediate steps , switch the electricity off at the socket and remove the plug. Remove any objects that are covering the product.

CAUTION: Do not touch the heater as it will be hot. Set the heater switches to OFF and leave the heater to cool down fully. Once completely cool, reconnect the heater and switch it on. Do not open this product , There are no user-serviceable parts.

11.0 CLEANING AND MAINTENANCE

ALWAYS DISCONNECT THE APPLIANCE FROM THE MAINS SUPPLY OUTLET SOCKET BEFORE UNDERTAKING ANY CLEANING OR MAINTENANCE!

For general cleaning use a soft clean duster - never use harsh abrasive or cleaners. The glass panels should be cleaned carefully with a soft cloth.

If in doubt consult a qualified electrician. Refer to Section 3.0 Appliance Data for fuse specification. Excluding fuses, use only genuine manufacturers spare parts available from your supplier.

12.0 REPLACE THE LED STRIP

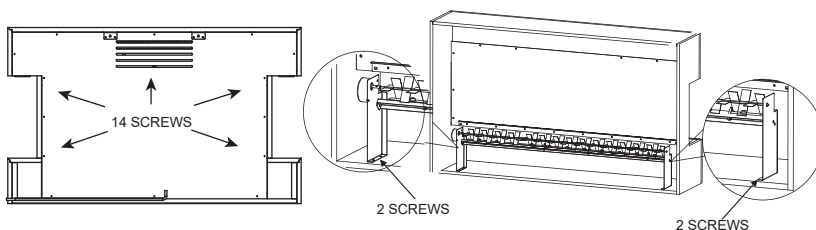

1. Remove the plug from the wall socket.
2. Remove the rear panel of the suite by removing the 14 screws.
3. Carefully pull the rear MDF panel away and place to one side.
4. Remove the 2 screws that hold the motor left bracket.
5. Remove the 2 screws that hold the spindle right bracket.
6. Remove the LED strip and unplug the small connector.
7. Replace this with the new LED strip and reassemble the fire.

13.0 TROUBLESHOOTING GUIDE

GB IE

Fire is not switching on	Ensure mains switch is on Replace the fuse in the plug.
Pebbles glow but flame effect does not work	Check to see if the spinning motor is working. If not contact Focal Point Fires.
Heater doesn't work, but Power and Heater switches / buttons are in the "ON" position	Turn all switches / buttons to the "OFF" position and unplug the unit from the wall outlet for 5 minutes. After 5 minutes plug the unit back into wall outlet, and operate as normally.
Fire seems noisy	There is a level of noise when the flame effect is in use, caused by a motor that helps generate the effect. This noise will be heard when there is no other background noise. There is a higher level of noise associated with the heater motor; this is due to the air flow required when heat has been selected.

14.0 SERVICING

There are no internal user serviceable parts.

Check regularly for security of wall fixings as appropriate. Also check security of supply cable and connections. If the supply cable becomes damaged, it must be replaced by a service agent or competent person, such as a qualified electrician.

This appliance is supplied with a BS1363 3 pin plug fitted with a 13 Amp fuse. Should the fuse require replacing, it must be replaced with a fuse rated at 13 Amp and approved to BS1362. In the event of the mains plug being removed/ replaced for any reason, please note : **IMPORTANT:** The wires in the mains lead are coloured in accordance with the following code:

Blue - Neutral

Brown - Live

Green/ Yellow - Earth

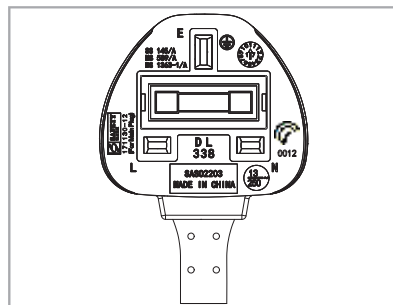

As the colours of the wires in the mains lead of this appliance may not correspond with the colour markings identifying the terminals in your plug, proceed as follows.

The blue wire must be connected to the terminal marked with an N or coloured black. The brown wire must be connected to the terminal marked with an L or coloured red. The green/yellow wire must be connected to the earth terminal which is marked with an E or with the earth symbol.

WARNING: Never connect live or neutral wires to the earth terminal of the plug.

NOTE: If a moulded plug is fitted and has to be removed take great care in disposing of the plug and severed cable, it must be destroyed to prevent engaging into a socket.

Refer to Section 3.0, Appliance Data for fuse specification. Excluding fuses, use only genuine manufacturers spare parts available from your supplier.

15.0 APPLIANCE DIMENSIONS

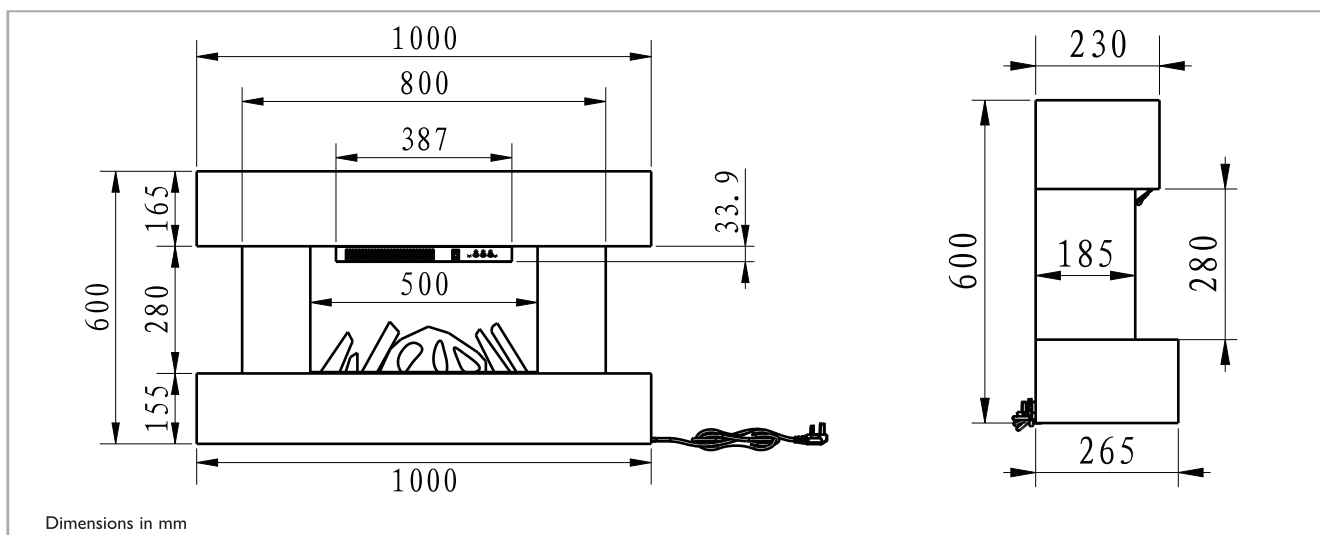

Registration is not required.

Appliances purchased prior to 1st February 2009, and those specifically marked as '1 year guarantee' on this website, are guaranteed for one year from the date of purchase, provided that the following three terms and conditions are adhered to:

1. For any claim to be made within 1 year from date of purchase you will be required to provide and supply us with your original proof of purchase.
2. Your gas fire must have been commissioned by Gas Safe registered installer, evidence of which you must provide together with the registration number.
3. All appliances must have been installed and operated in accordance with the manufacturer's instructions.

3 Year Guarantee Terms and Conditions

Please be advised that the 3 year guarantee only covers products purchased on or after 1st February 2009.

The 3 year guarantee is only applicable to purchases made through an authorised stockist/retailer. Please see our website for a list of authorised stockists. Any purchase(s) made through an unauthorised stockist(s) will be eligible for a statutory 1 year guarantee.

For all gas fires purchased the 3 year guarantee commences from the date of purchase, provided that the following 4 terms and conditions are adhered to:

1. For any claim to be made within the 3 years from date of purchase you will be required to provide and supply us with your original proof of purchase.
2. Your gas fire must have been commissioned by Gas Safe registered installer, evidence of which you must provide together with the registration number.
3. Your appliance must have been serviced annually by Gas Safe registered installer, evidence of which must be provided, such as the receipt.
4. Purchase(s) must be made through an authorised stockist/retailer.

Please note all consumable items such as any ceramics including; coals, pebbles, the matrix, front strips, side cheeks, rear panels and tapered rear panels are not covered by the 3 year guarantee.

During the guarantee period any product or component which is proved to be faulty or defective in manufacture, will be repaired or replaced free of material and labour charges, providing that we have authorised or carried out the repair or replacement.

We will not accept or reimburse the costs of any third party who undertakes any work carried on the product or fits parts, unless we have approved such work in advance of it being carried out.

The guarantee period will not be extended even if we repair or replace any product or part.

For all electric fires purchased the 3 year guarantee commences from the date of purchase, providing that you can supply the proof of purchase. This does not cover consumable items such as pebbles, coals or light bulbs. Purchase(s) must be made through an authorised stockist.

Making a claim:

Making a claim is easy. If you wish to make a claim under our guarantee and all the terms and conditions for your product have been met then please submit the following information for the attention of the 3G Service Department to the address below. Alternatively, you can email or fax.

Focal Point Fires, 3G Service Department, Reid Street, Christchurch, Dorset, BH23 2BT.

Email: 3g@focalpointfires.co.uk,

Fax. 01202 588639.

Details required:

1. Name, full address including postal code and contact telephone number.
2. A copy of your proof of purchase e.g. receipt or bank statement.
3. Original installers Gas Safe registration number (gas fires only).
4. Annual service receipt for every 12 months (gas fires only).

Please note that this does not affect your statutory rights.



This product complies with conformity requirements of the applicable European Regulations or Directives.



This product complies with conformity requirements of the applicable UK Regulations.



Waste electrical products should not be disposed of with household waste. Please recycle where facilities exist. Check with your local authority or retailer for recycling advice. As our policy is one of continuous improvement and development, we therefore hope that you will understand we must retain the right to amend details and/or specifications without prior notice.

