

EN Frame fixing short expansion
FR Cheville courte d'expansion pour cadres
PL Kołek ramowy z krótką częścią rozporową
RO Diblu pentru fixare cadre cu zonă de expansiune scurtă
ES Fijación de estructura corta de expansión
PT Estrutura de fixação de expansão curta
TR Kısa şaftlı çerçeve dübeli

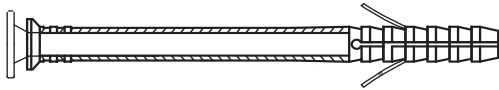

V10425_5059340430355_MAND2_2324

EN DIM FR DIM PL WYMIARY RO DIM. ES DIM PT DIM TR BYT	EAN	EN PACK SIZE FR QUANTITÉ PAR PAQUET PL LICZBA SZTUK W OPAKOWANIU RO NUMĂR DE BUCĂȚI ÎN PACHET ES UNIDADES DEL PACK PT QUANTIDADE POR EMBALAGEM TR PAKET BOYUTU
8 x 60 mm	5059340426822	6
8 x 60 mm	5059340426815	6
8 x 100 mm	5059340426808	6
10 x 100 mm	5059340426792	6
10 x 120 mm	5059340426785	6
10 x 140 mm	5059340426778	6
10 x 160 mm	5059340426761	6
10 x 140 mm	5059340430331	12
10 x 160 mm	5059340430324	12
8 x 100 mm	5059340430355	12
8 x 120 mm	5059340430348	12
10 x 100 mm	5063022532084	12
10 x 120 mm	5063022531865	12
10 x 200 mm	5063022531926	12
10 x 100 mm	5063022531254	40
10 x 120 mm	5063022531216	40
10 x 140 mm	5063022531995	40
10 x 160 mm	5063022531889	40
8 x 120 mm	5063022531414	40
8 x 60 mm	5063022531841	12
8 x 80 mm	5063022531537	12

EN You will need **FR** Vous aurez besoin de **PL** Będziesz potrzebować **RO** Vei avea nevoie de **ES** Necesitará **PT** Vai precisar de **TR** İhtiyaç duyacaklarınız

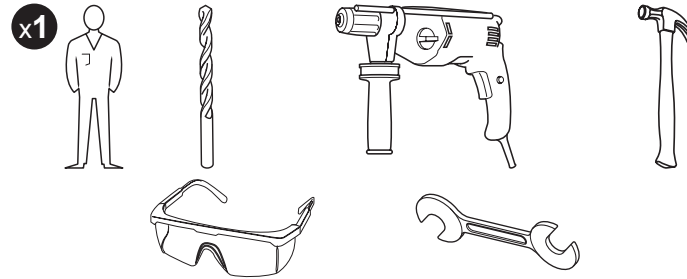

EN Safety **FR** Sécurité **PL** Bezpieczeństwo **RO** Siguranță
ES Seguridad **PT** Segurança **TR** Güvenlik

EN Before you start

Wear protective glasses.

FR Avant de commencer

Porter des lunettes de protection.

PL Przed rozpoczęciem użytkowania

Założyć okulary ochronne.

RO Înainte de a începe

Poartă ochelari de protecție.

ES Antes de empezar

Utilice gafas protectoras.

PT Antes de começar

Utilize óculos de proteção.

TR Başlamadan önce

Koruyucu gözlük takın.

EN IMPORTANT - These instructions are for your safety. Please read through them thoroughly prior to handling the product and retain them for future reference.
FR IMPORTANT : Ces instructions sont données pour votre sécurité. Merci de les lire attentivement avant de manipuler le produit et de les conserver pour référence.
PL WAŻNE — Niniejsza instrukcja została opracowana w celu zapewnienia bezpieczeństwa użytkownikowi. Należy ją dokładnie przeczytać przed obsługą produktu i zachować do wykorzystania w przyszłości.
RO IMPORTANT - Aceste instrucțiuni sunt pentru siguranța ta. Citește-le cu atenție înainte de montarea produsului și păstrează-le pentru consultare ulterioară.
ES IMPORTANTE: Estas instrucciones son para su propia seguridad. Léelas atentamente antes de manipular el producto y guárdelas para futuras consultas.
PT IMPORTANTE - Estas instruções são para sua segurança. Leia-as atentamente antes de manusear o produto e guarde-as para consultas futuras.
TR ÖNEMLİ - Bu talimatlar sizin güvenliğiniz içindir. Ürün üzerinde çalışmaya başlamadan önce lütfen bu talimatları dikkatlice okuyun ve ileride başvurmak üzere saklayın.



Manufacturer • Fabricant • Producent • Producător • Fabricante:

UK Manufacturer:

Kingfisher International Products Limited, 1 Paddington Square, London, W2 1GG, United Kingdom

EU Manufacturer:

Kingfisher International Products B.V., Rapenburgerstraat 175E, 1011 VM Amsterdam, The Netherlands

EN www.diy.com / www.screwfix.com / www.screwfix.ie

To view instruction manuals online, visit www.kingfisher.com/products

FR www.castorama.fr / www.bricodepot.fr / www.screwfix.fr

Pour consulter les manuels d'instructions en ligne, rendez-vous sur le site www.kingfisher.com/products

PL www.castorama.pl

Aby zapoznać się z instrukcją obsługi online, odwiedź stronę www.kingfisher.com/products

RO www.bricodepot.ro

Pentru a consulta manualele de instrucțiuni online, vizitați www.kingfisher.com/products

ES www.bricodepot.es

Para consultar los manuales de instrucciones en línea, visite www.kingfisher.com/products

PT www.bricodepot.pt

Para consultar manuais de instruções online, visite www.kingfisher.com/products

TR İthalatçı Firma:

KOÇTAŞ YAPI MARKETLERİ TİCARET A.Ş. Sırrı Çelik Bulvarı Otokoç Blok No:9 Çekmeköy/İstanbul 34788 Türkiye

Telefon: (90) 216 430 03 00 / Faks: (90) 216 484 43 13 / www.koctas.com.tr

Kullanım kılavuzuna internet üzerinden ulaşmak için www.kingfisher.com/products adresini ziyaret edin

Yetkili servis istasyonları ve yedek parça temini için aşağıda yer alan Koçtaş Müşteri Hattı ve Koçtaş Genel Müdürlük irtibat bilgilerinden faydalanınız.

KOÇTAŞ MÜŞTERİ HİZMETLERİ
0850 209 50 50

01

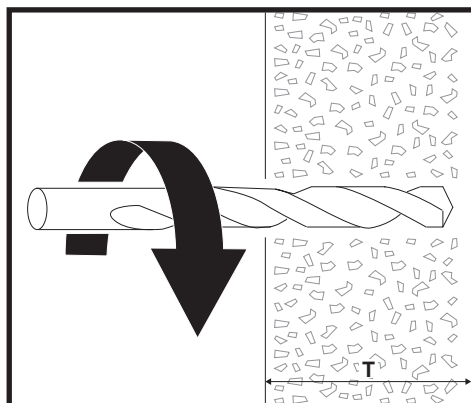

EN DIM FR DIM PL WYMIARY RO DIM. ES DIM PT DIM TR BYT	EN Min drilling depth T (mm) FR Profondeur de perçage min. T (mm) PL Minimalna głębokość wiercenia T (mm) RO Adâncime min. de găurire T (mm) ES Profundidad mín. de perforación T (mm) PT Profundidade mínima de perfuração T (mm) PR Min. delme derinliği T (mm)
8 x 60 mm	65
8 x 80 mm	85
8 x 100 mm	105
8 x 120 mm	125
10 x 100 mm	105
10 x 120 mm	125
10 x 140 mm	145
10 x 160 mm	165
10 x 200 mm	205

02

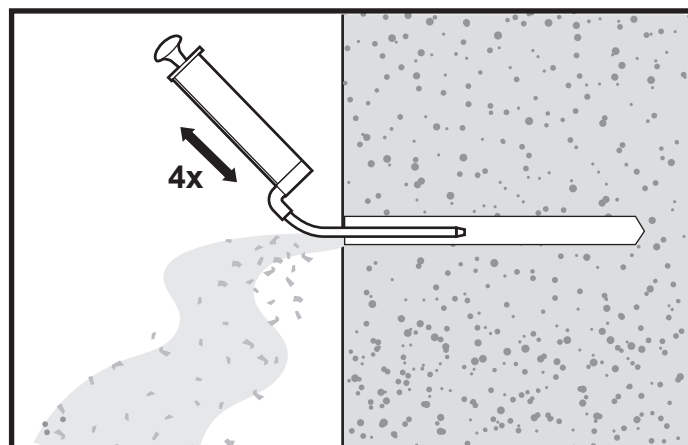

03

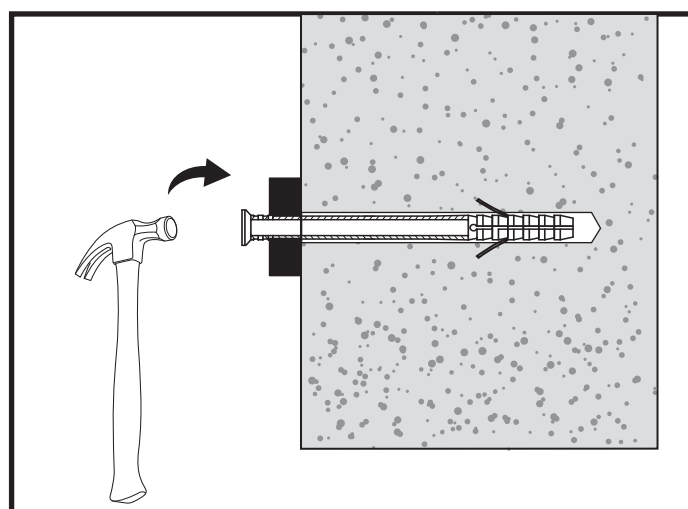

04

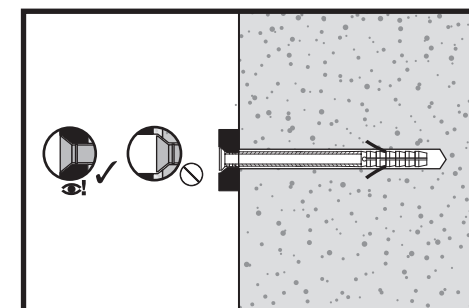

05

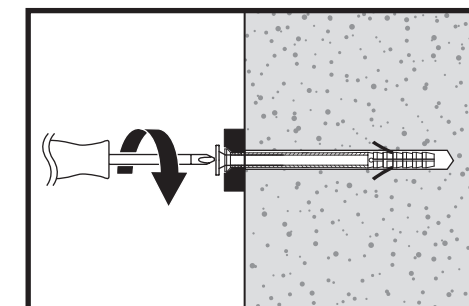

06

