

EN Semora New Century 2.4 m x 2.6 m

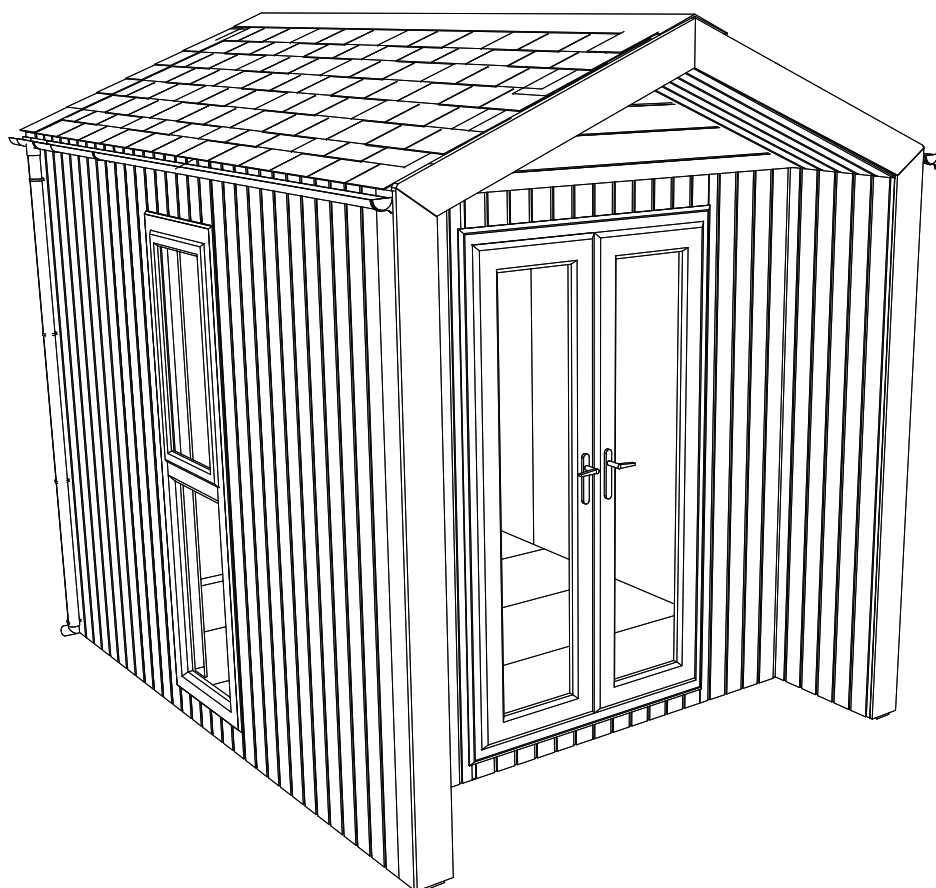

EN IMPORTANT - These instructions are for your safety. Please read through them thoroughly prior to handling the product and retain them for future reference.

V10324_5059340679549_MAND2_2324

5059340679549
5059340854588
5059340854496

EN Parts

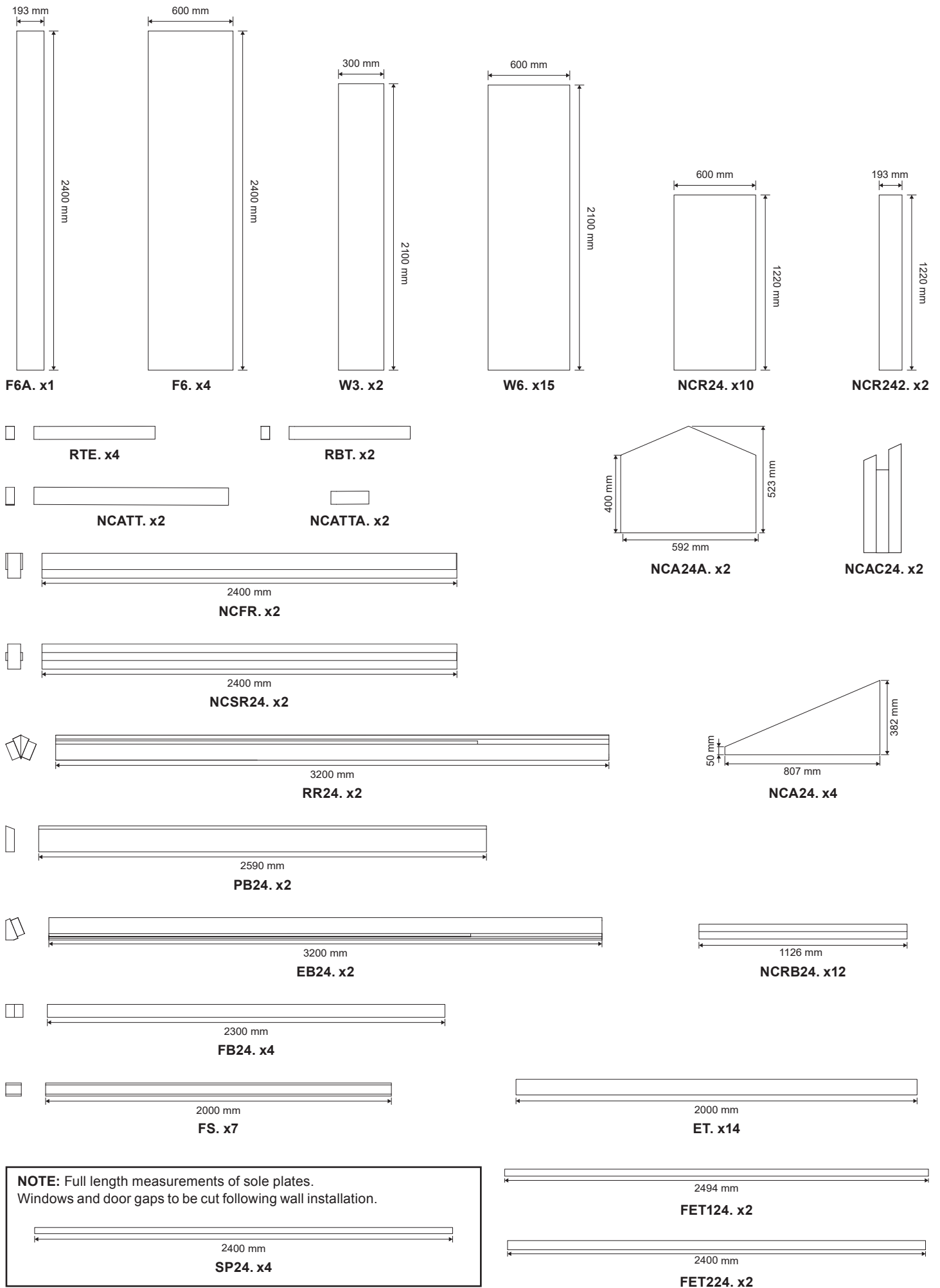

INTERNAL CLADDING

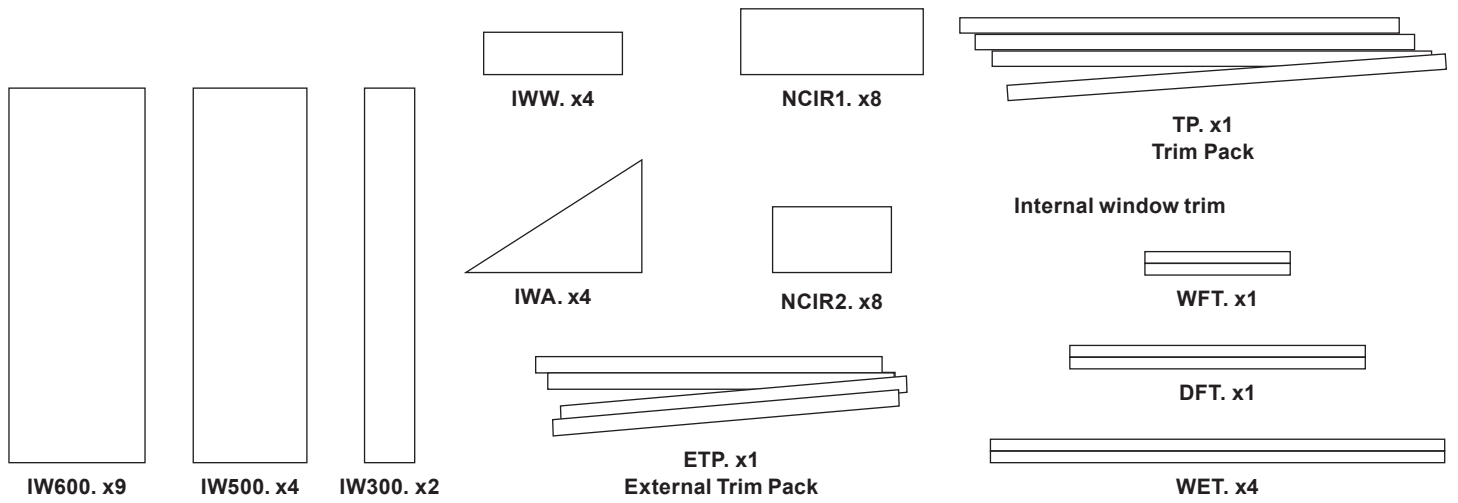

EXTERNAL CLADDING

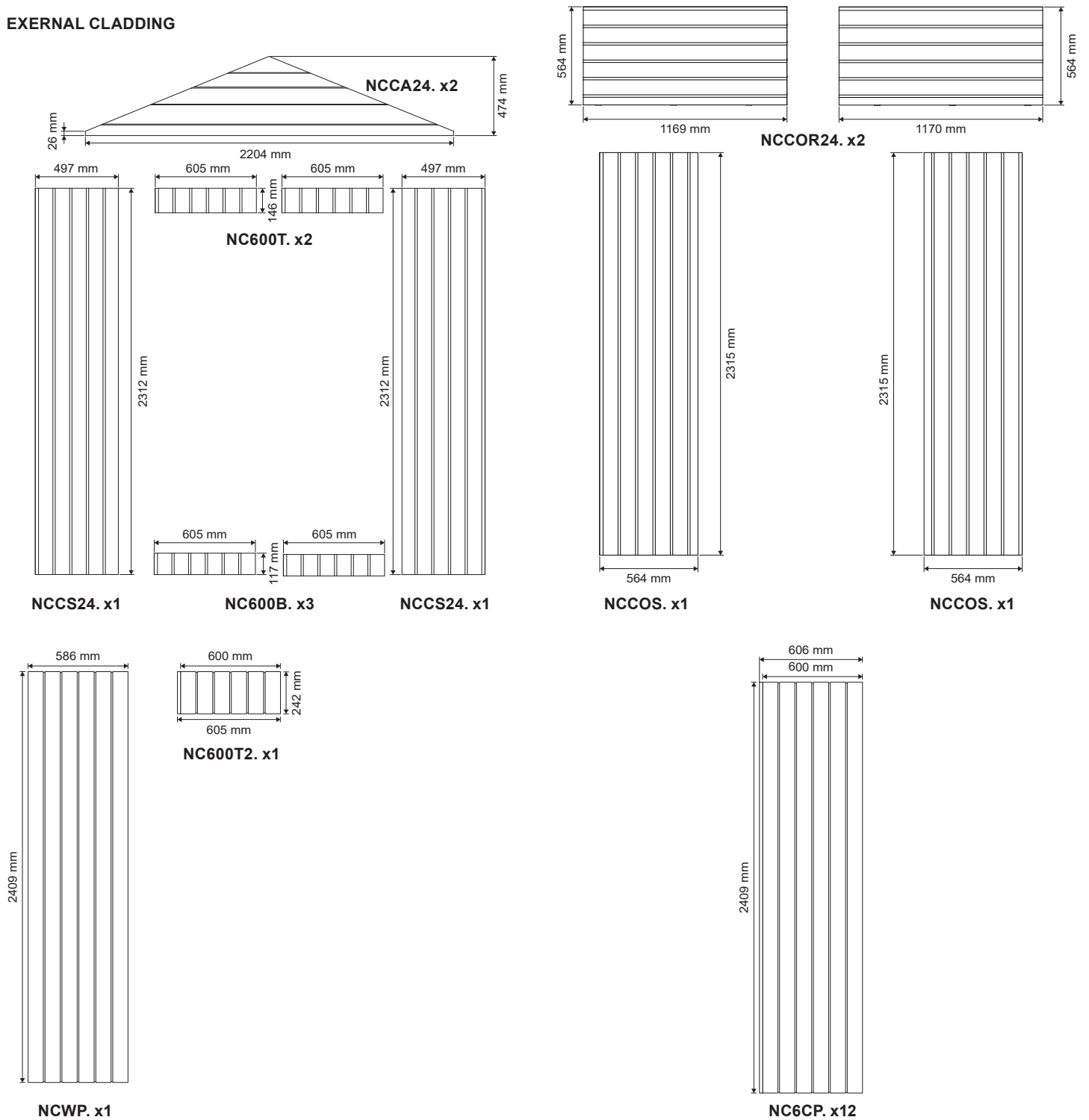

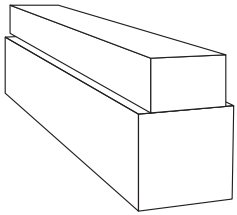

OA. x4

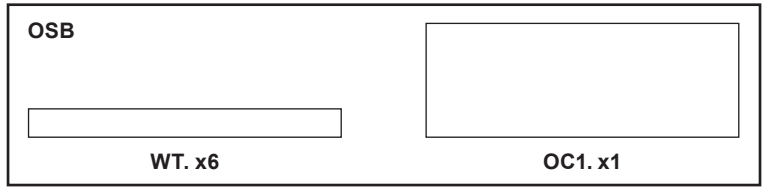

2600 mm

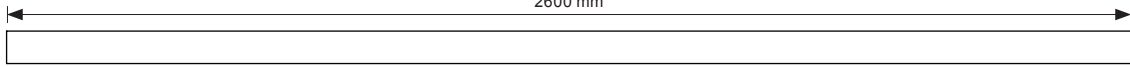

BR124. x3

3200mm

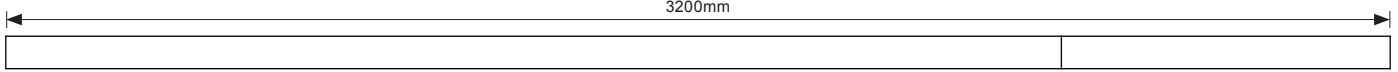

BR224. x2

760 mm

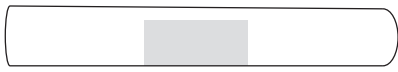

BM. x1
50 m Roll

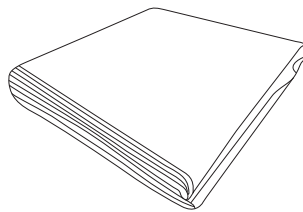

DPM. x1



PU Glue. x1



SEALANT. x1

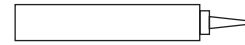

INTERNAL CAULK. x1

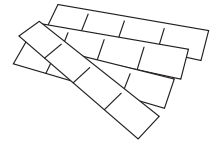

RS. x5

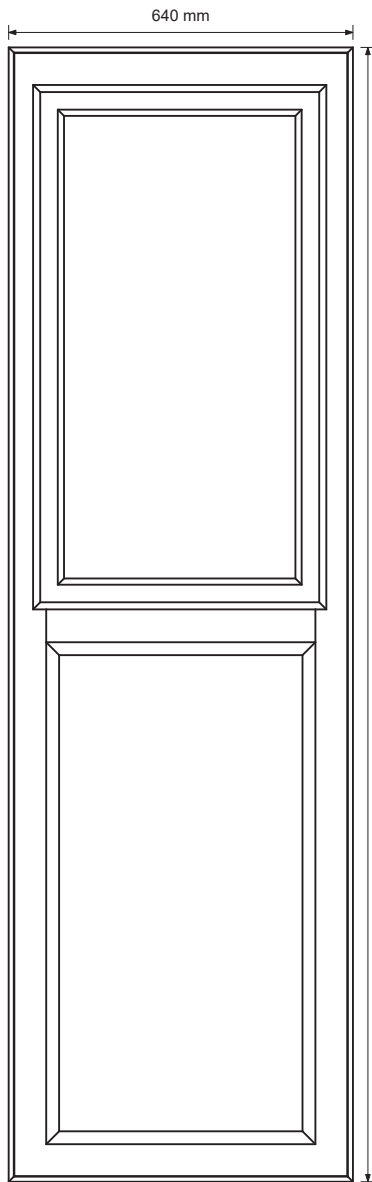

SOW. x1

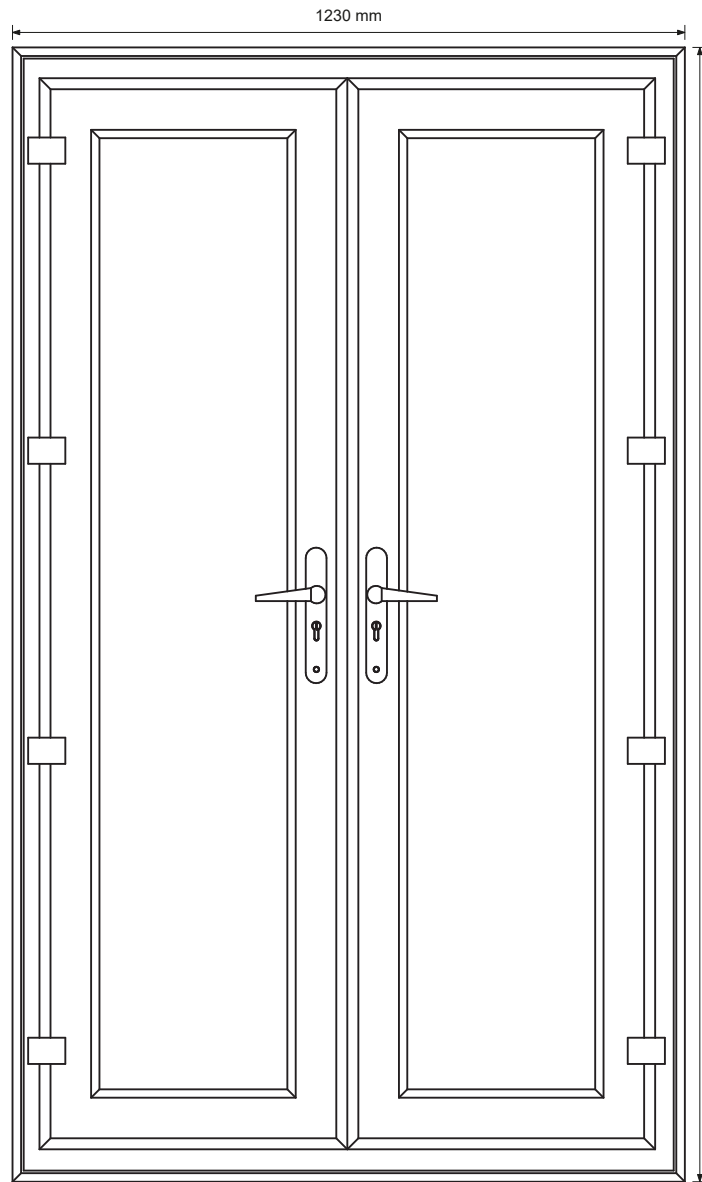

DD. x1

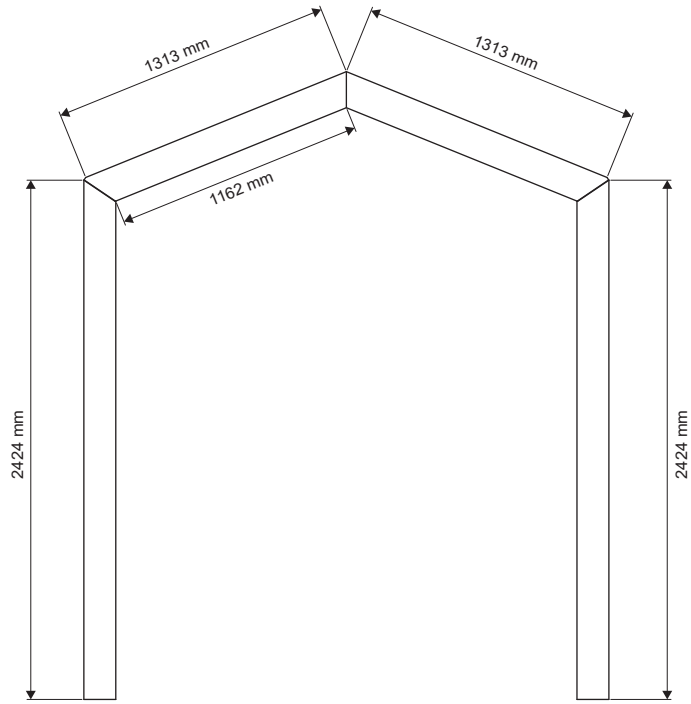

NCTP. x2

GP GUTTER PACK

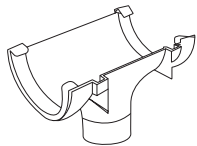

GP. x2

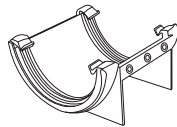

GP. x2

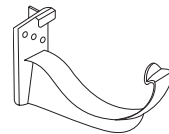

GP. x8

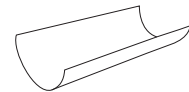

GP. x4

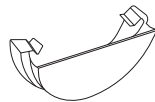

GP. x4



GP. x8

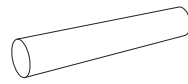

GP. x2



GP. x2

SUPPLIED FIXINGS

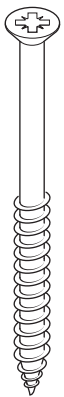

S150

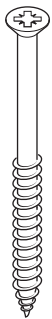

S80

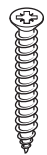

S30



S50

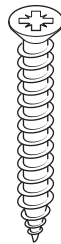

S60



PP



CN



VP

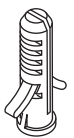

RP

EN You will need



EN Contents

EN	
Safety	7
Guarantee	7
Preparation	8
Installation	9
Care & maintenance	49

EN Before you start

- Please check all components are present before you start building. Ensure there are no missing or damaged parts.

Safety

- Please read the instruction manual carefully before undertaking the construction of your garden room.
- Ensure that instruction manual is retained for future reference.
- The garden room must be installed by a minimum of 2 adults who are proficient in the skills required to complete the task as outlined in the instruction manual.
- Ensure that you have all the tools specified in the instruction manual available before undertaking the product construction.
- Handle any tool used carefully and in accordance with their instructions.
- Keep children and animals away from the assembly site.
- Some parts of the garden room kit have sharp edges and can cause damage. Be sure to wear personal protective equipment: work gloves, long sleeves and goggles.
- Wear safety goggles for eye protection when using machine tools. Make sure power tools are well sealed to avoid any risk of electric shock.
- When using a ladder, make sure it is stable on the ground.
- Do not try to assemble the garden room in high winds, as the work site may become hazardous.
- Be careful when working on the roof and use appropriate safety equipment.
- Do not modify the construction or design of this product. Failure to follow this instruction could lead to injury, death or property damage.
- Refrain from using this product for anything other than its intended purpose.
- Check all the instructions including application, shelf-life, storage, cautions and health and safety sections of the chemical products supplied with the kit, which will be listed on the back of each product, before use. Should you have any concerns or require further information this can be found online or provided on request from supplier/manufacturer of these specific product brands.
- Dispose of any unused parts of the kit and waste responsibly.

Guarantee

We take special care to select high quality materials and use manufacturing techniques that allow us to create products incorporating design and durability. SEMORA Garden Room Kit Product Guarantees guarantee against manufacturing defects, from the date of delivery (online purchase only), at no additional cost for normal (non-commercial) and intended use.

Please see the table below for details of the length of our SEMORA Product Guarantees.

Guarantee period	Products covered
10 years	Main structural components including Floor, Wall and Roof Structural Insulated Panels (SIPs), Door and windows, EPDM Rubber Roofing (SEMORA Modern) / Roofing Felt and Shingles (SEMORA New Century)

This guarantee covers product failures and malfunctions provided the product was used for the purpose for which it is intended and subject to installation, cleaning, care, and maintenance in accordance with the information contained in these Terms and Conditions, in the Instruction Manual and standard practice, provided that standard practice does not conflict with the Instruction Manual.

This guarantee does not cover defects and damage caused by the natural wear of parts, bad weather, flooding, heat releases, freezing, damage caused by water quality (hardness, aggressiveness, corrosion, etc.), by the presence of foreign bodies transported by water or otherwise (sand, filings, etc.) or the lack of room ventilation, and damages that could be the consequence of improper use, misuse, negligence, accident or maintenance that is defective or does not comply with good practice or the information in the Instruction Manual. This includes, but is not limited to:

- a) effects of weather exposure on the colour of the external cladding of the Product. Timber will naturally weather over time and to preserve its original colour it needs to be retreated every twelve (12) months after installation;
- b) appearance of natural properties of the Product's timber as a result from different environmental conditions, which may include changes in colour, immaterial surface splits, immaterial cracks, immaterial warpage, and immaterial shrinkage, insofar as these are that are not defects with the Product itself;
- c) door and window adjustments to the Product as may be reasonably necessary from time to time as part of the Product's maintenance;
- d) damage and/or faults caused to the Product by vermin or pests (such as insects, mice, rats, foxes, and birds);
- e) damage to the Product caused by storm-force weather conditions including flooding, standing water, or if the Product has been mis-used or deliberately abused;
- f) development of Product faults as a result from any structural alteration made to the building by the customer or a third party employed by the customer; and subject to installation care in accordance with the Instruction Manual;
- g) subsidence to the Product resulting from soil conditions and/or inadequate foundations.

If your SEMORA Garden Room is not constructed immediately after delivery or in one go, it is imperative that contents of the kit are stored inside or in a protected location. In such circumstances, it is recommended to leave the product in its original packaging. It must not be laid directly on the ground to prevent any contact with moisture. It is important that the storage location is flat, especially long-term, or the timber components may warp.

Product Guarantee is limited to those parts recognised as defective. Under no circumstances shall it cover fringe expenses (travel, labour) and direct and consequential damage.

Any Product Guarantee-related queries should be addressed to Customer Services helpline on 08081754011 (UK).

To make a claim under your Product Guarantee, you must present your proof of purchase (such as purchase invoice or other evidence admissible under applicable law), please keep your proof of purchase in a safe place. Unless stated otherwise by applicable law, any replacement product issued under your GoodHome guarantee will only be guaranteed until expiry of the original GoodHome guarantee period.

All claims must be made as soon as reasonably practicable once the defect has been discovered.

You may be asked to provide information, proof or evidence of the defect to help with the investigation/trouble shooting. The timeline for the resolution will be discussed with you at the time of the claim.

We reserve the right to instruct a third party of our choice to inspect the product to determine the cause of any alleged defect as part of the claims process. Where the product is no longer available, a replacement product of the same or similar specification may be provided at our discretion. These are the only remedies available under Product Guarantee.

The Product Guarantee is in addition to and does not affect your statutory rights.

IMPORTANT, RETAIN FOR FUTURE REFERENCE: READ CAREFULLY.

Planning

- Check local planning regulations before the build. SEMORA garden room design and its footprint fits within Permitted Development rights for outbuildings so Planning Permission is typically not required, however seek clarification with the local planning authority and ensure that the building and its location complies with their planning approval conditions.
- SEMORA garden room constructed under Permitted Development rights should not be used for habitable accommodation.

Foundations

- For this building to be long-lasting, it needs to be built on solid foundations.
- While there are two SEMORA foundation options to choose from, and you may have a preferred one, the final choice should always be based on the site conditions.
- With that in mind, we recommend booking a site-visit from a qualified surveyor to assess the soil or ground conditions you wish to build on and choose a suitable foundation system.

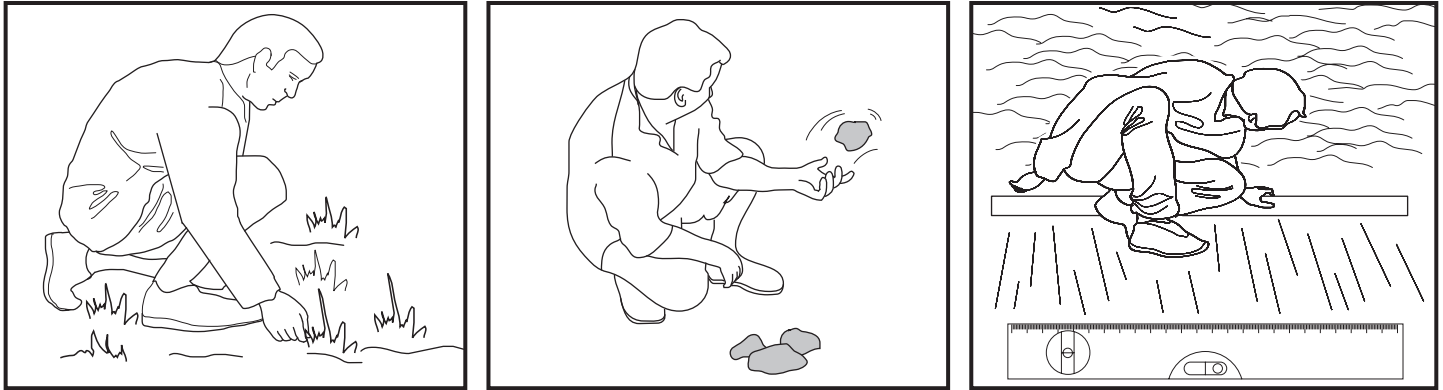

Concrete Slab Foundation

- A concrete base, if laid correctly, provides a consistently even and solid surface, which will keep the garden building stable and correctly aligned.
- If you already have a concrete base in place, intending to lay the base yourself or getting a local trade professional to do it for you, the base should be the same size as the footprint of your SEMORA garden room to allow rainwater to run straight off the building's roof and into the surrounding garden. A base too large will increase the risk of water ingress as rain will bounce off a concrete rim around the building and onto the timber walls.
- With that in mind, the base generally should be made about 50 mm bigger than the footprint of the garden room. This offers a degree of tolerance to ensure the building is fully supported.
- If using existing concrete slab foundation, we recommend having your foundations assessed by a professional to avoid any disappointment or unexpected costs.
- We also strongly recommend getting tradesman help when laying a concrete base to ensure that garden room is built on solid foundations, which will make it last in the long run.
- While >150 mm concrete slabs, laid over compacted hardcore and sand are typical for a garden room, the depth of the slab should be decided following a site survey where the ground is assessed along with the size and intended use of the building.

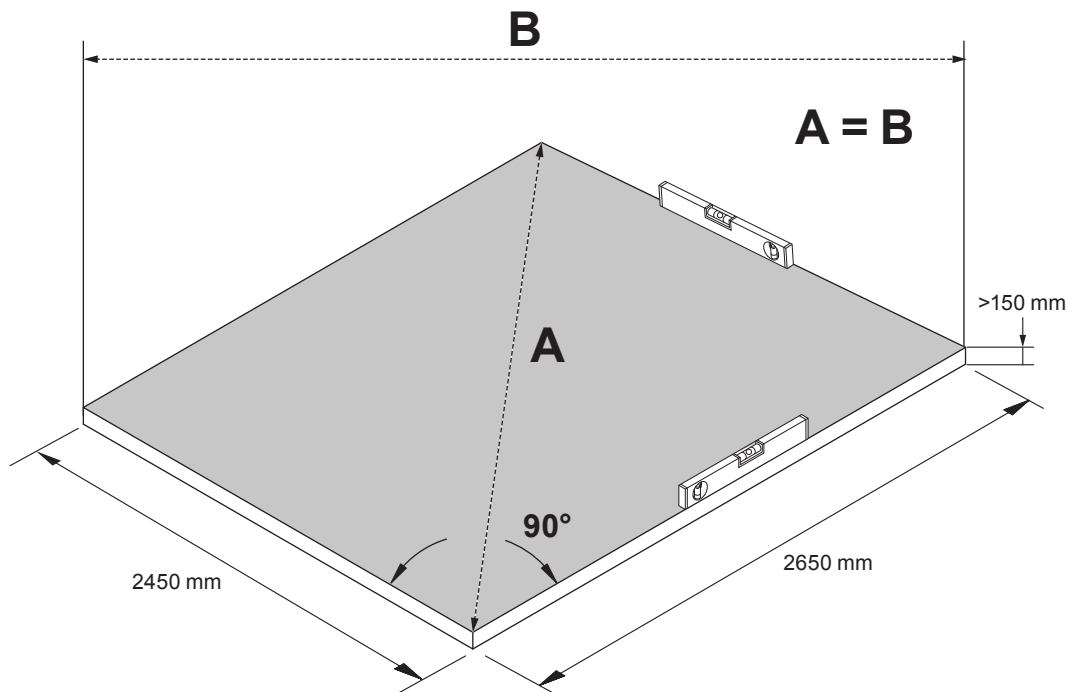

Preparing the concrete foundation

01

Bearer layout

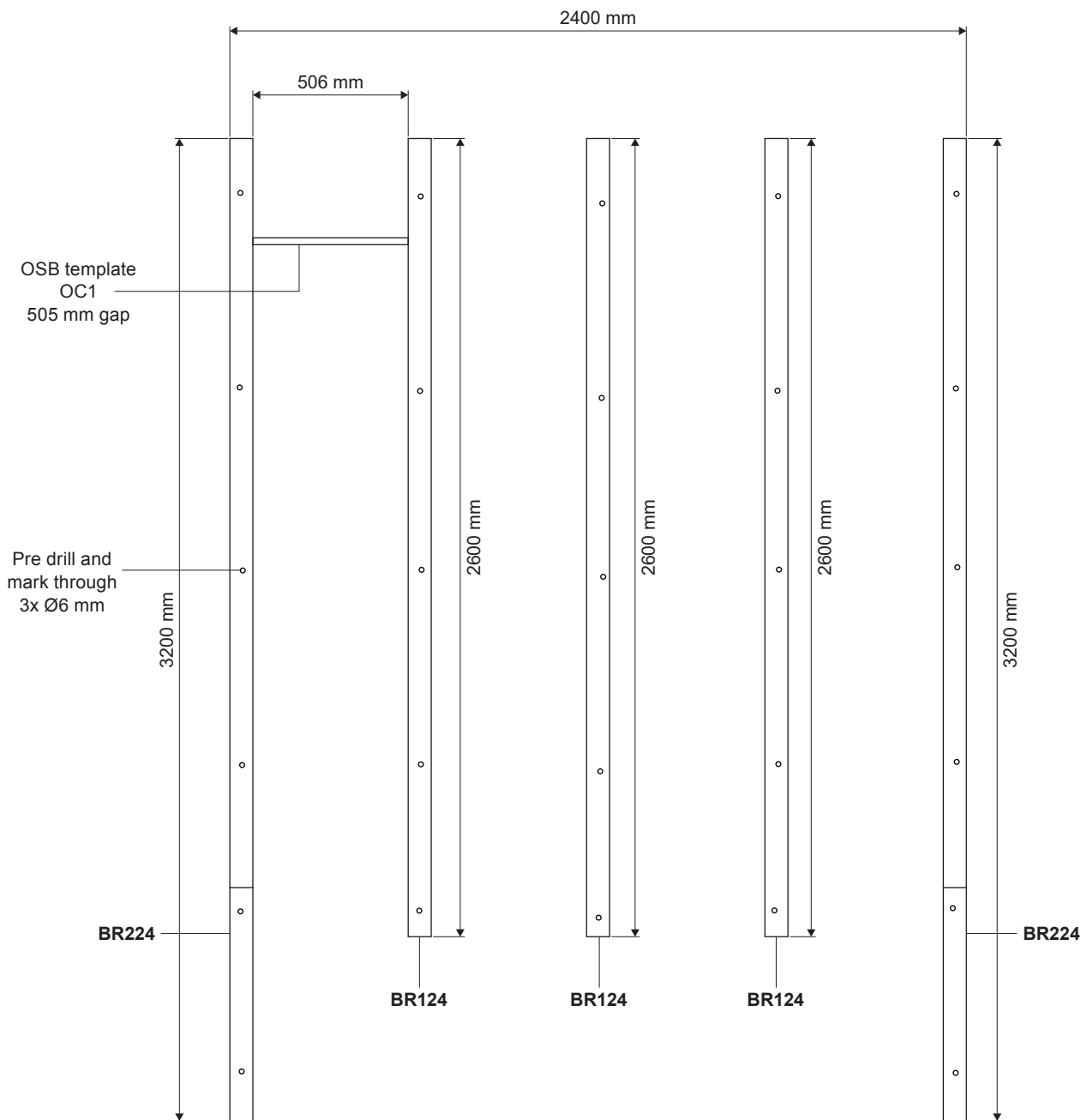
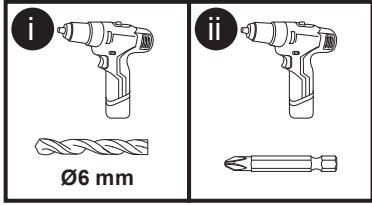

Starting with the longer BR224 bearer, put it into place and secure with 3 S80 screws. A suitable wall plug RP should be used. Secure at the front, middle and back. Using the supplied OSB template OC1, space the next bearer BR124 and secure with 3 screws, repeat the process to the last BR224 bearer. The bearers should be 2400 mm total edge to edge across the base.

02

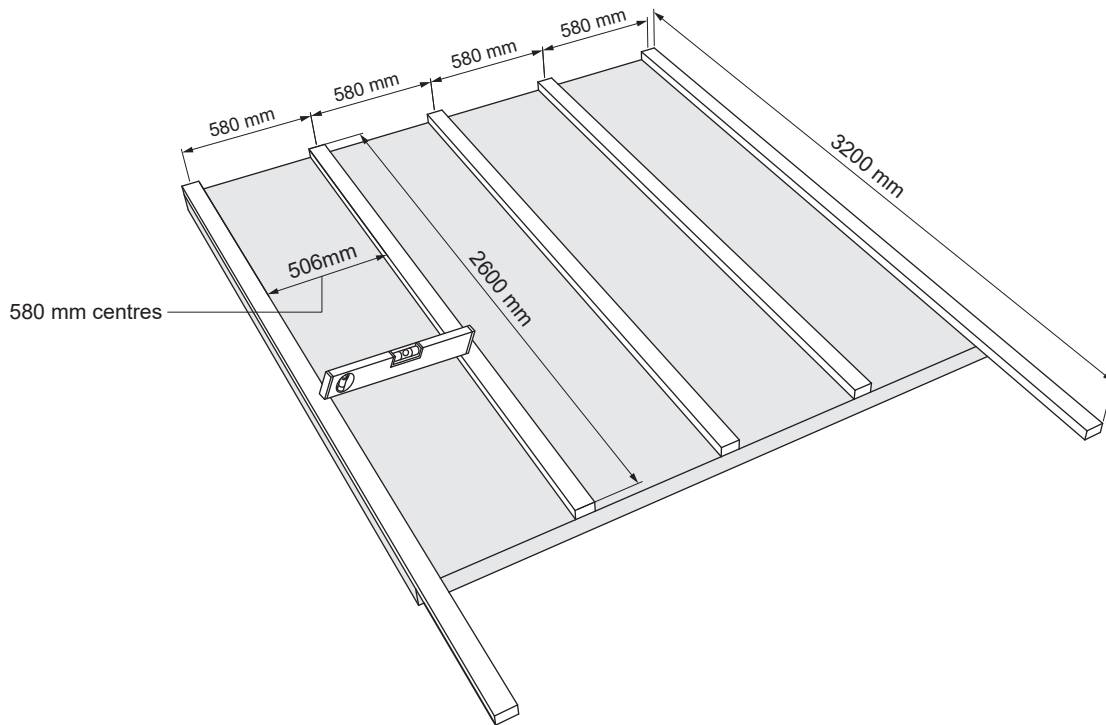

Concrete base must be at least the size of the shorter bearers. Before proceeding to the next step use spirit level to ensure that secured bearers are level and use packers if any alignment is necessary.

03

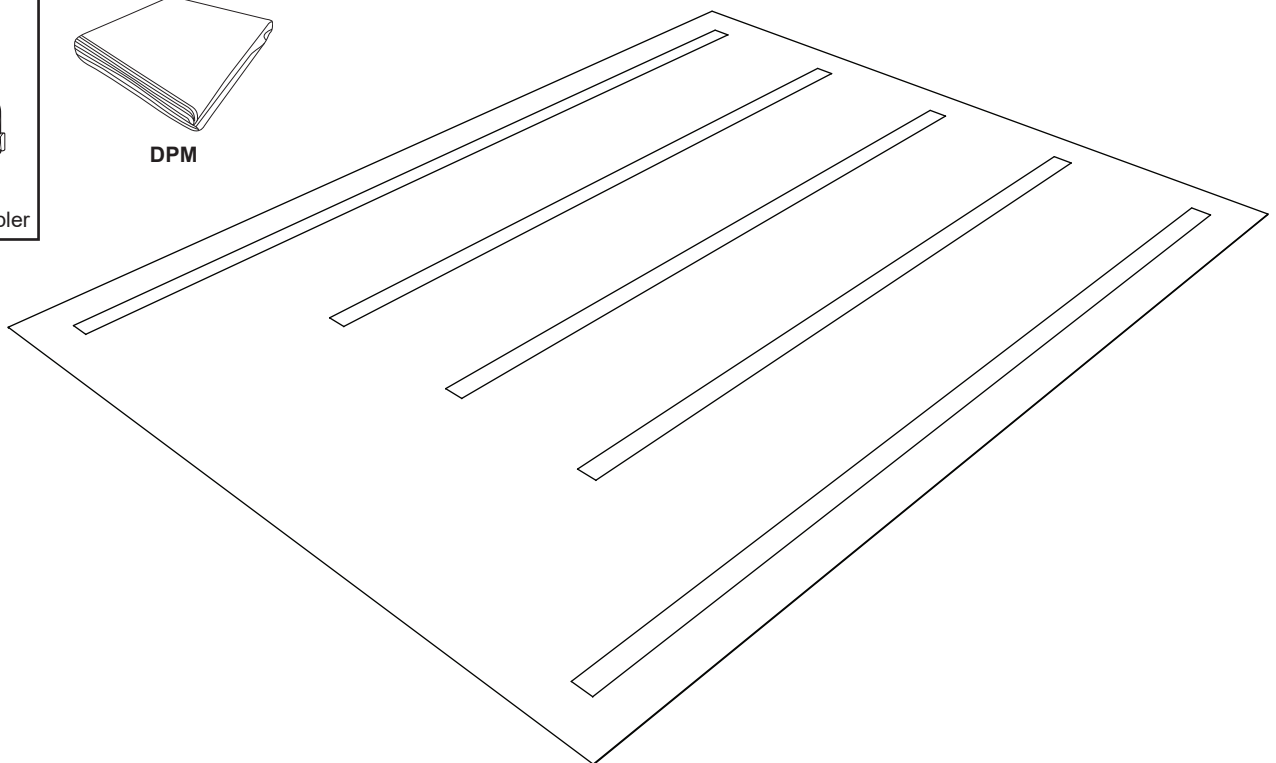
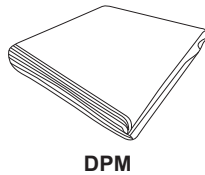
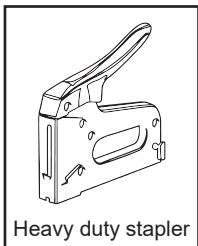

DPM membrane over floor bearers.

Lay the damp proof membrane DPM down over the bearers with a 150 mm overhang on all edges. Staple the membrane across the length of the first bearer and pull it taut over the bearers. Secure with at least 4 staples to each bearer to prevent the membrane folding and creasing.

04

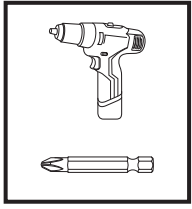

S50

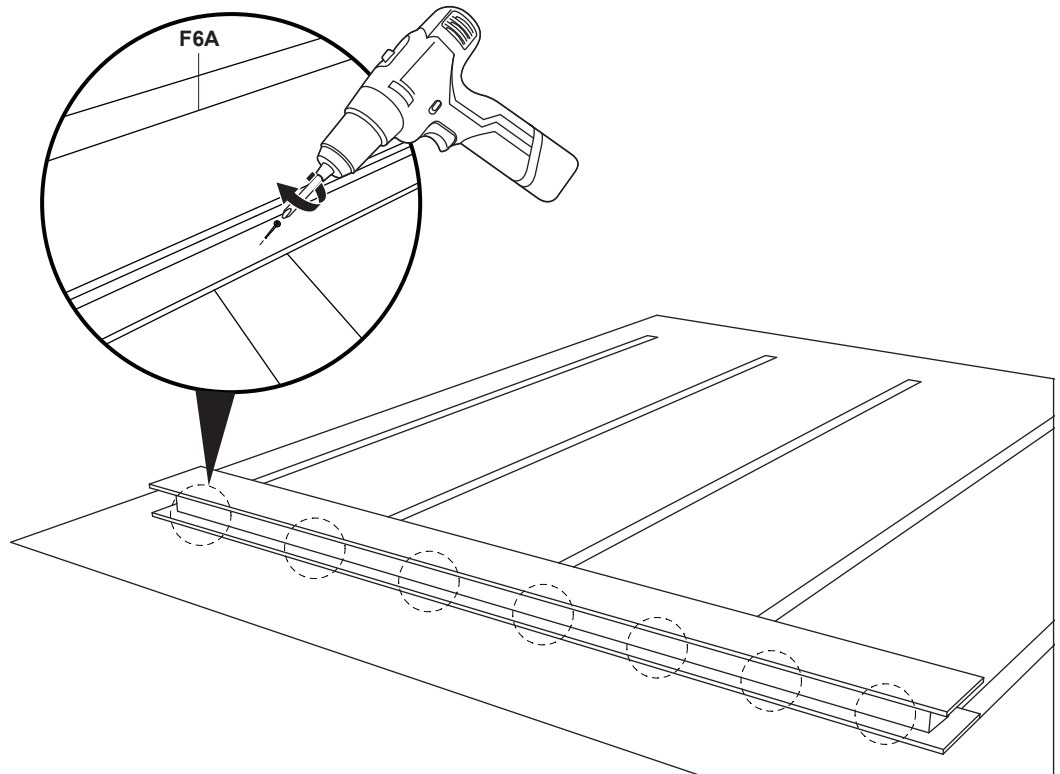

Ensure screws are driven below surface to prevent snagging.

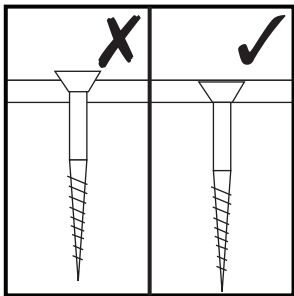

Place your first row of panels onto the bearers level with the ends of the bearers. Secure the panels to the bearers with S50 screws through edge of SIP panel. Remember to sink screws into OSB to prevent snagging. Joining SIP panels will be from the top.

05

Floor construction

x4

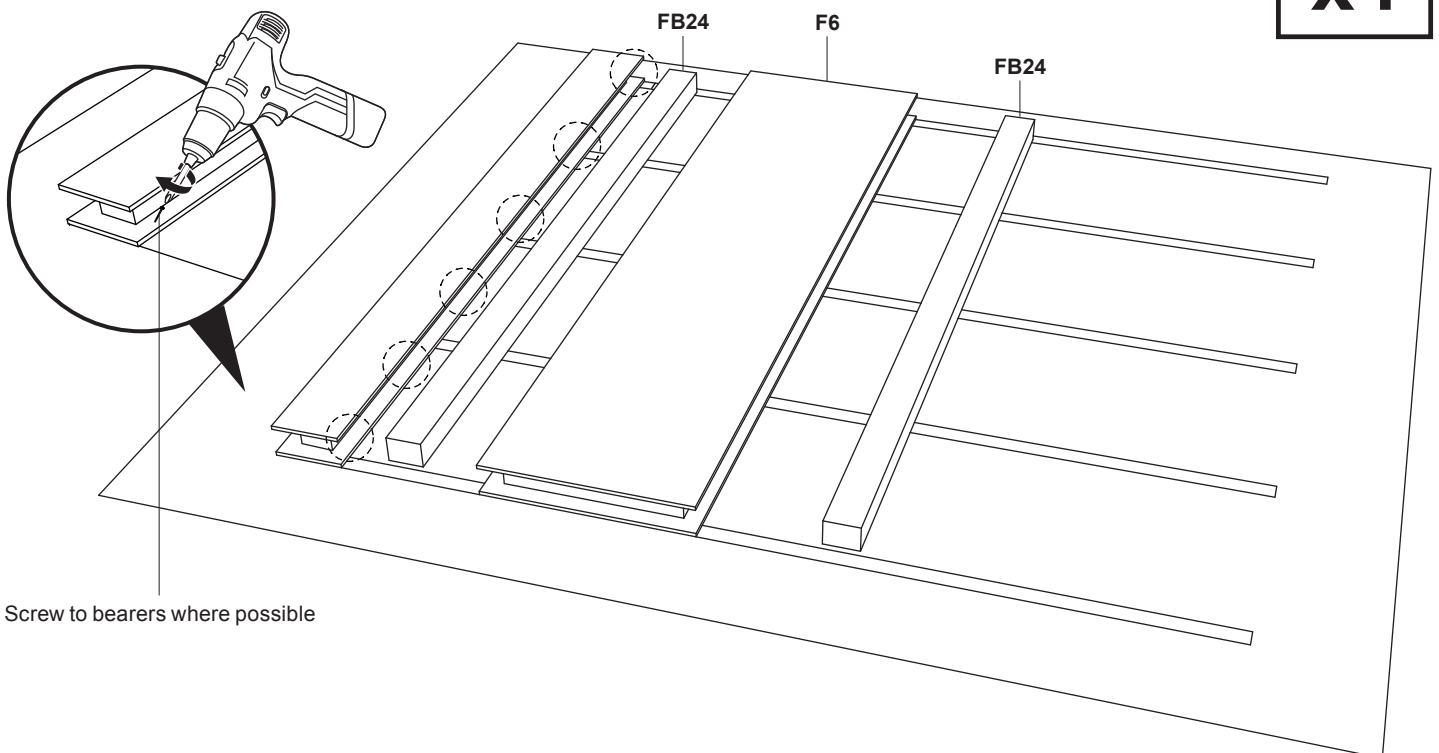

Screw each panel to bearer through edge of SIP panel using S50 screws.

06

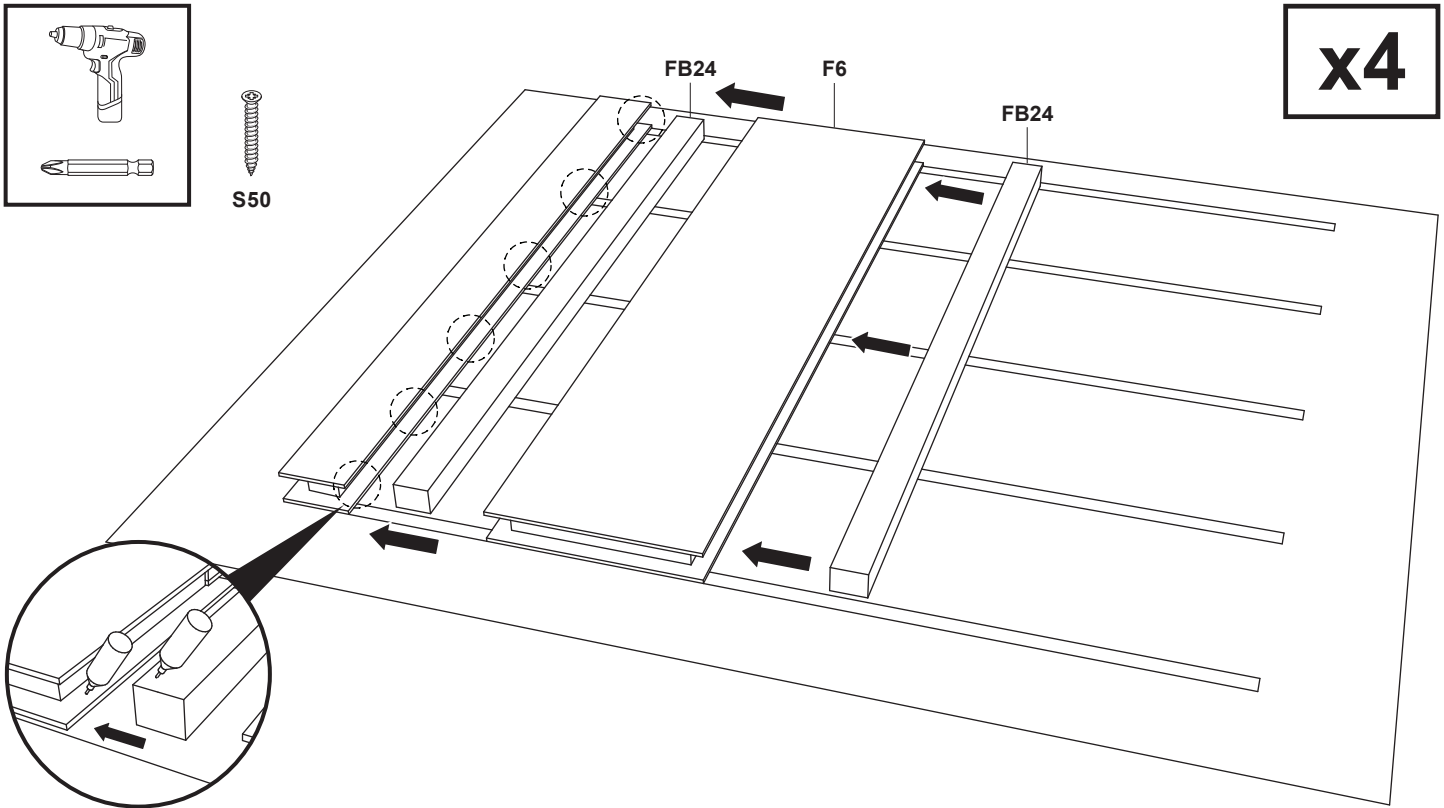

Apply glue to the SIP panel rebate as shown and to the top of the floor beam FB24. Insert the floor beam FB24 in the panel rebate and ensure it is level with the foam.

07

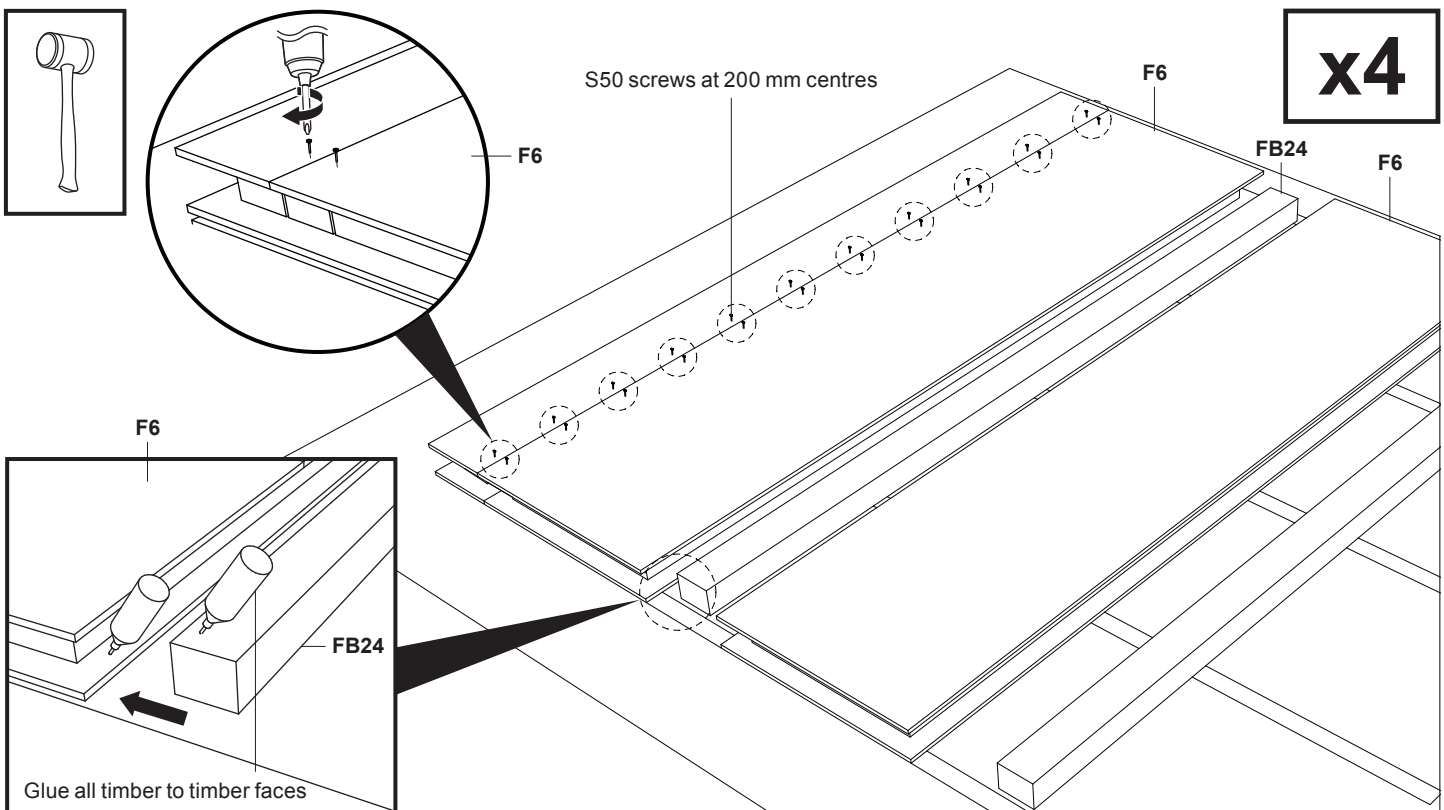

Use a rubber mallet, if required, to tap floor panels into place. Be careful not to break the edges of OSB or insulation. Secure panels from the top with S50 screws. Follow the same steps for the remaining floor panels. Remember to stand on the bearers until you have enough panels to stand on.

08

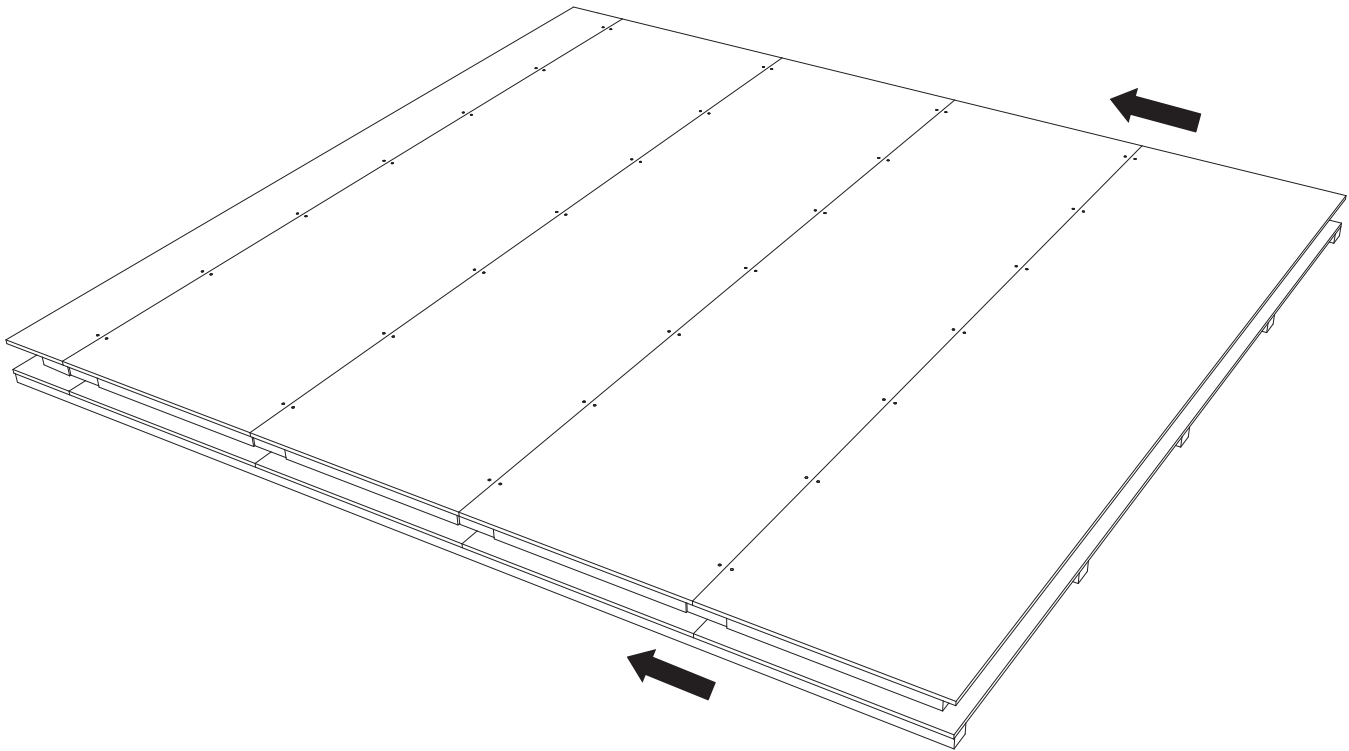

Ensure the outside edges are screwed to the bearers all the way round and all edges line up to the outside of the bearers.

09

Floor edge timbers

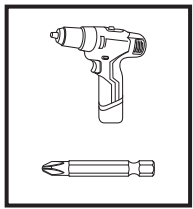

S50

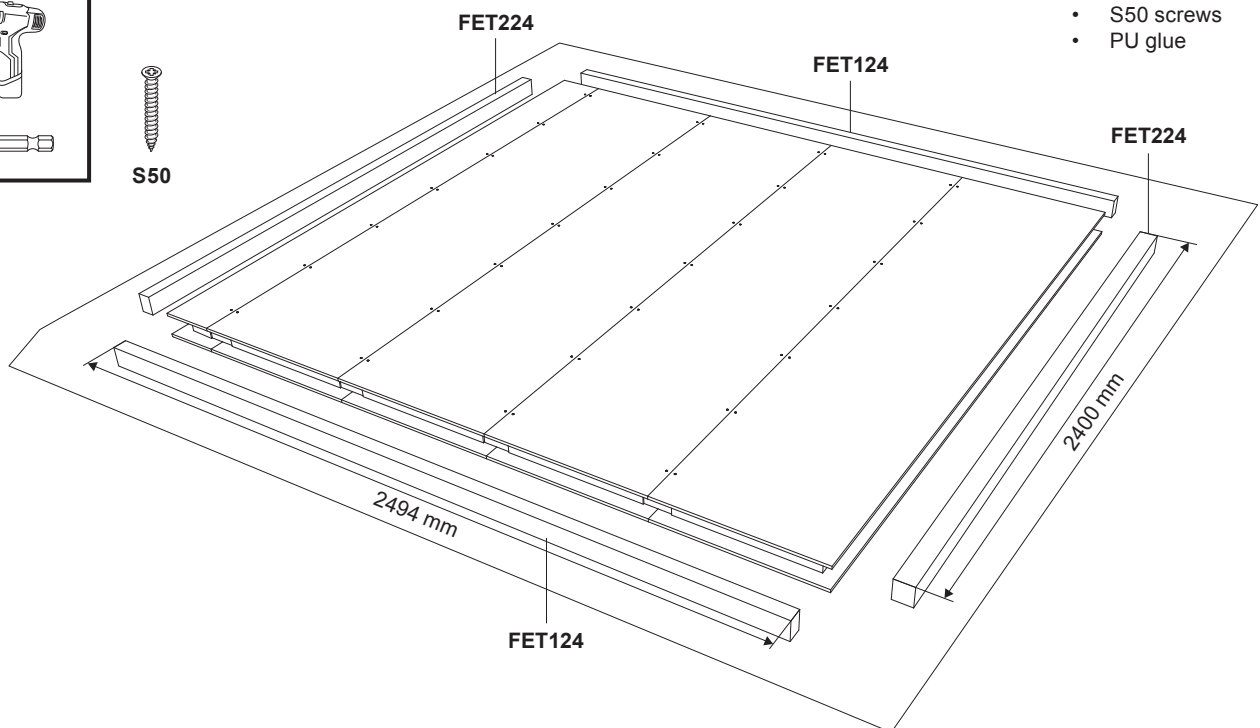

Check fitting first and ensure floor panel rebates are free from debris.
Place the floor edge timbers into the outside rebate of the floor, glue and screw.

10

Sole plates

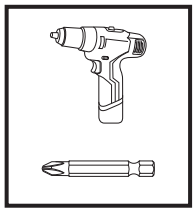

S80

- Glue and screw sole plates
- S80 screws (3 per metre)
 - PU glue

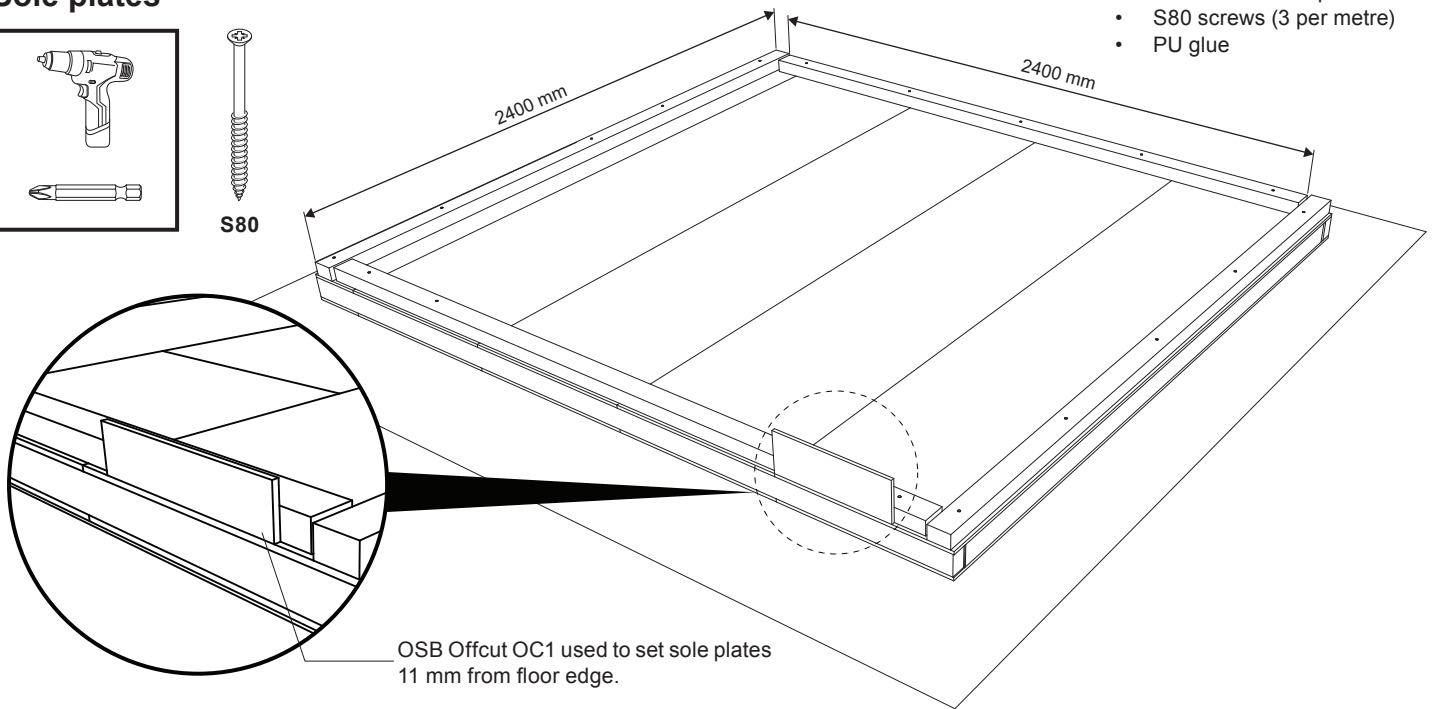

OSB Offcut OC1 used to set sole plates
11 mm from floor edge.

Decide at this stage where you want the windows and doors to go and mark off on the floor do not glue under the sole plate so it can be removed. Measure 600 mm sections for windows and 1200 mm for doors.

11

Sole plates position

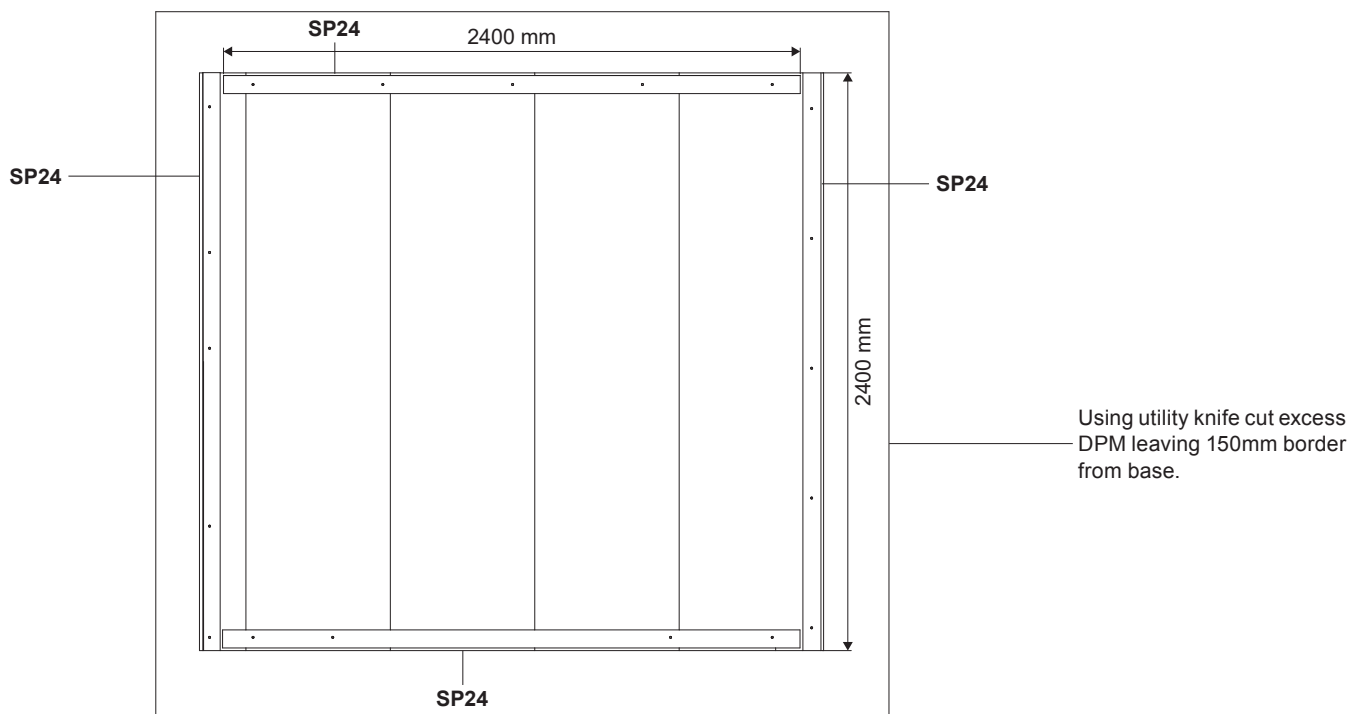

Window positions are set at this stage.

Windows can replace panels on any wall except for corner panels use a piece of OSB to set sole plate 11 mm from edge.

12

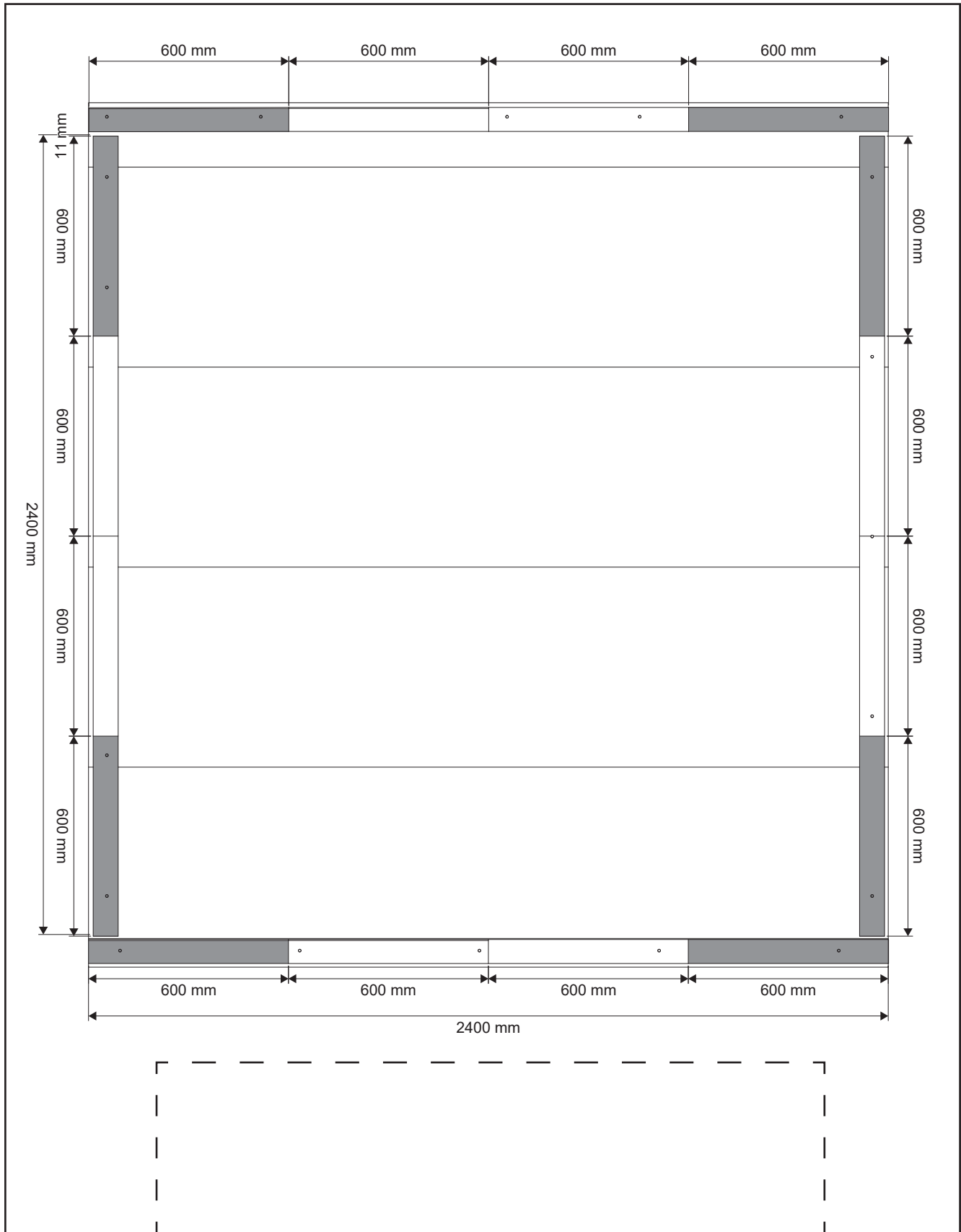

■ Area not possible to add window

Lay all sole plates in place using standard plan. Decide where you want your windows and doors.

The diagram below shows where windows and doors can be placed. The grey areas show where you cannot have a door or window.

* Doors and windows cannot be directly placed next to each other.

13

Walls

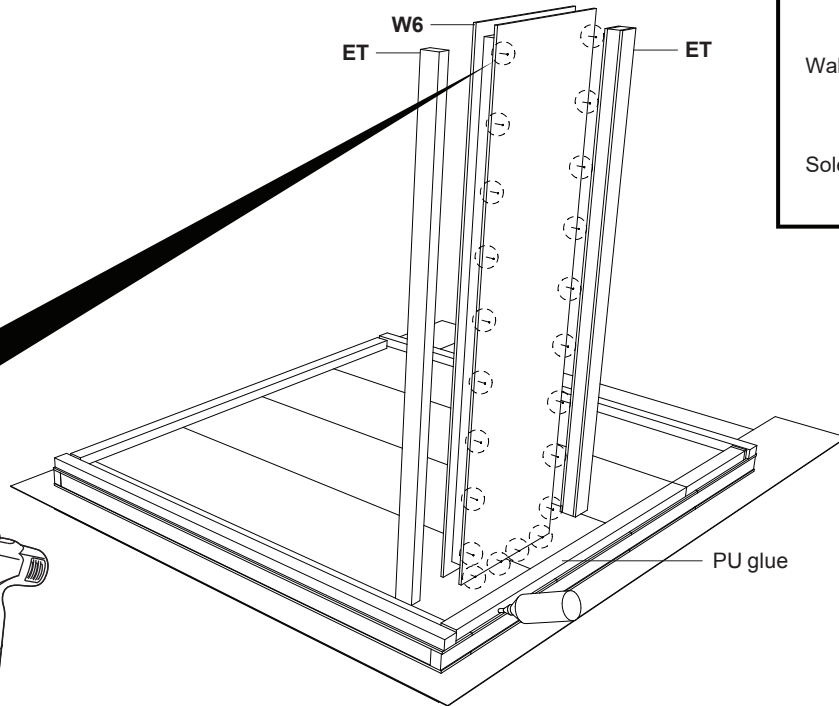
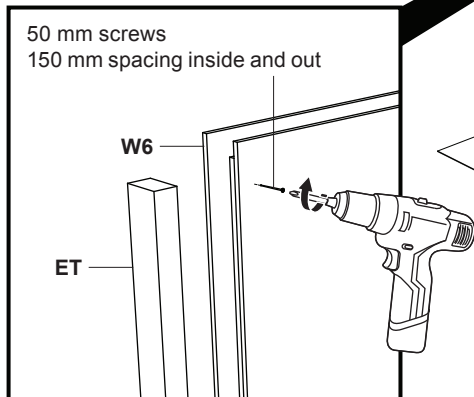
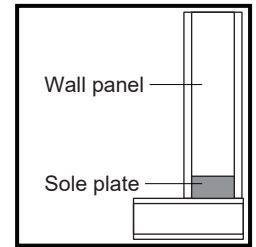
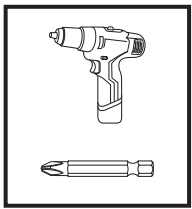

Starting in the corner fix your first panel.
The panel W6 sits astride the sole plate. Glue to the sole plate and fix the timber edges ET with S50 screws.
Ensure the timber edge sits on the sole plate.

14

Insert edge timbers

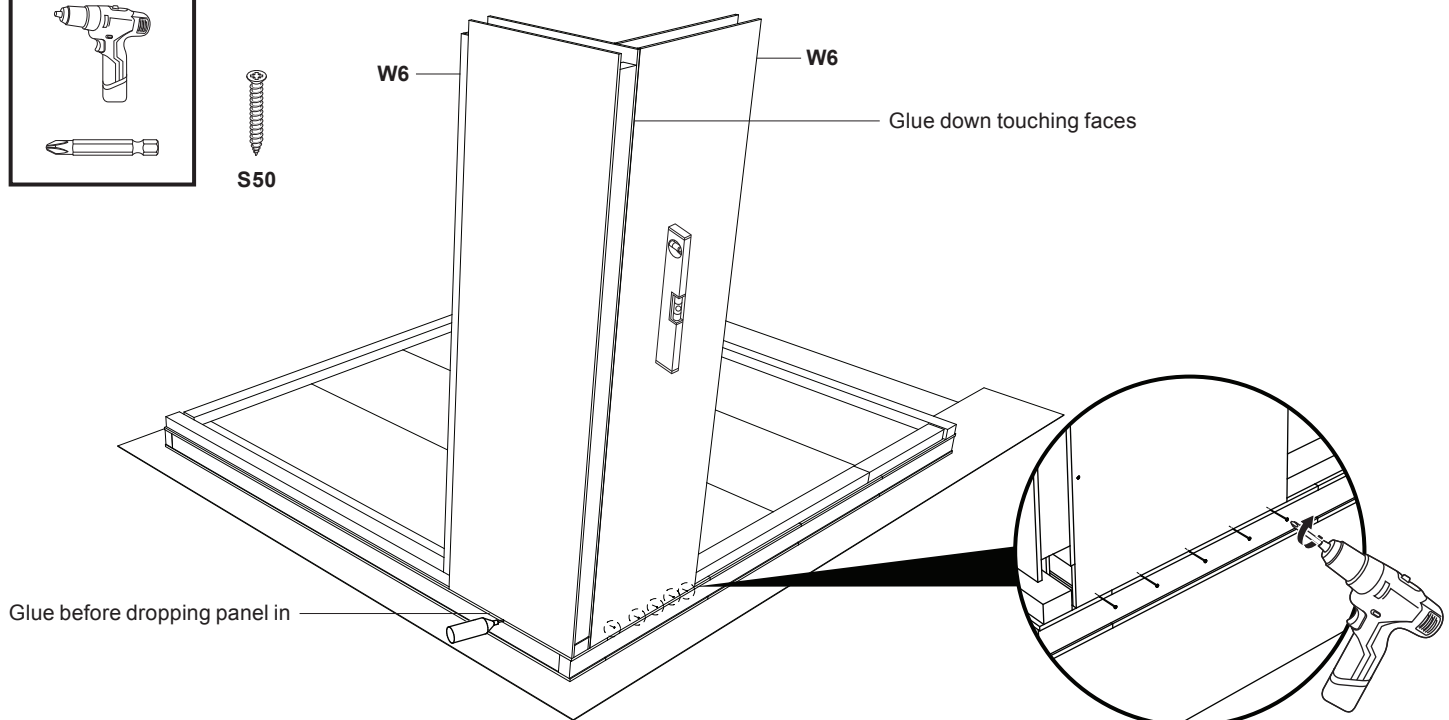
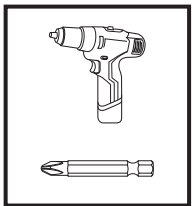

Once you have the corner two W6 panels in place finish fixing the panels at the bottom with S50 screws.

15

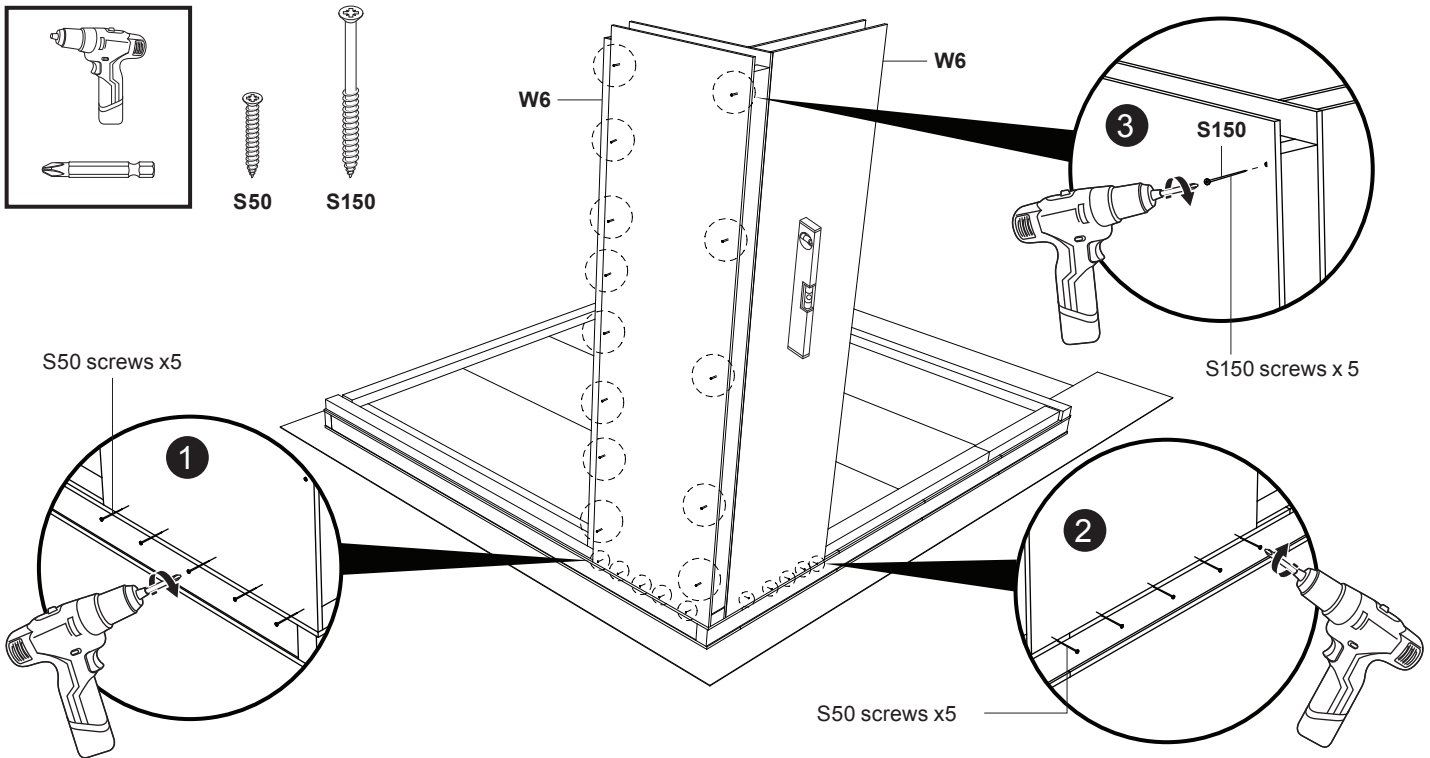

Ensure corner is plumb before progressing. Use impact driver or power driver to install 150 mm screws.

16

Wall build

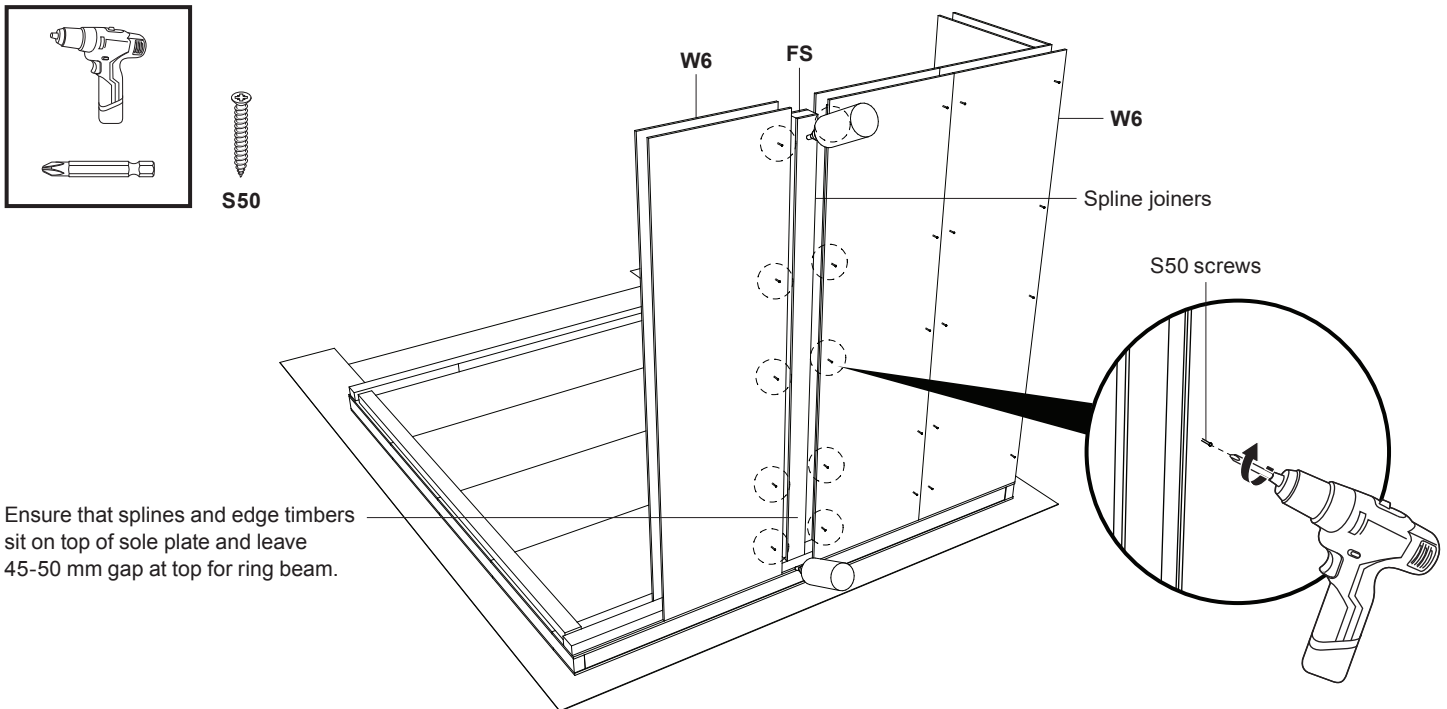

Continue to build your walls using FS splines to FS join the panels with glue and screws.

17

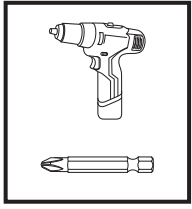

S50



S150

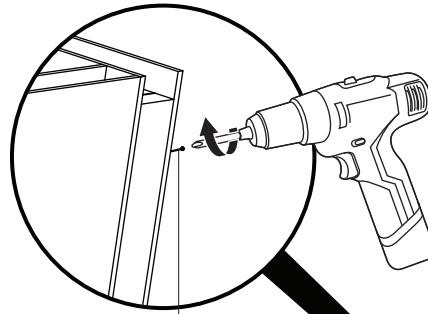

S150 screws x5

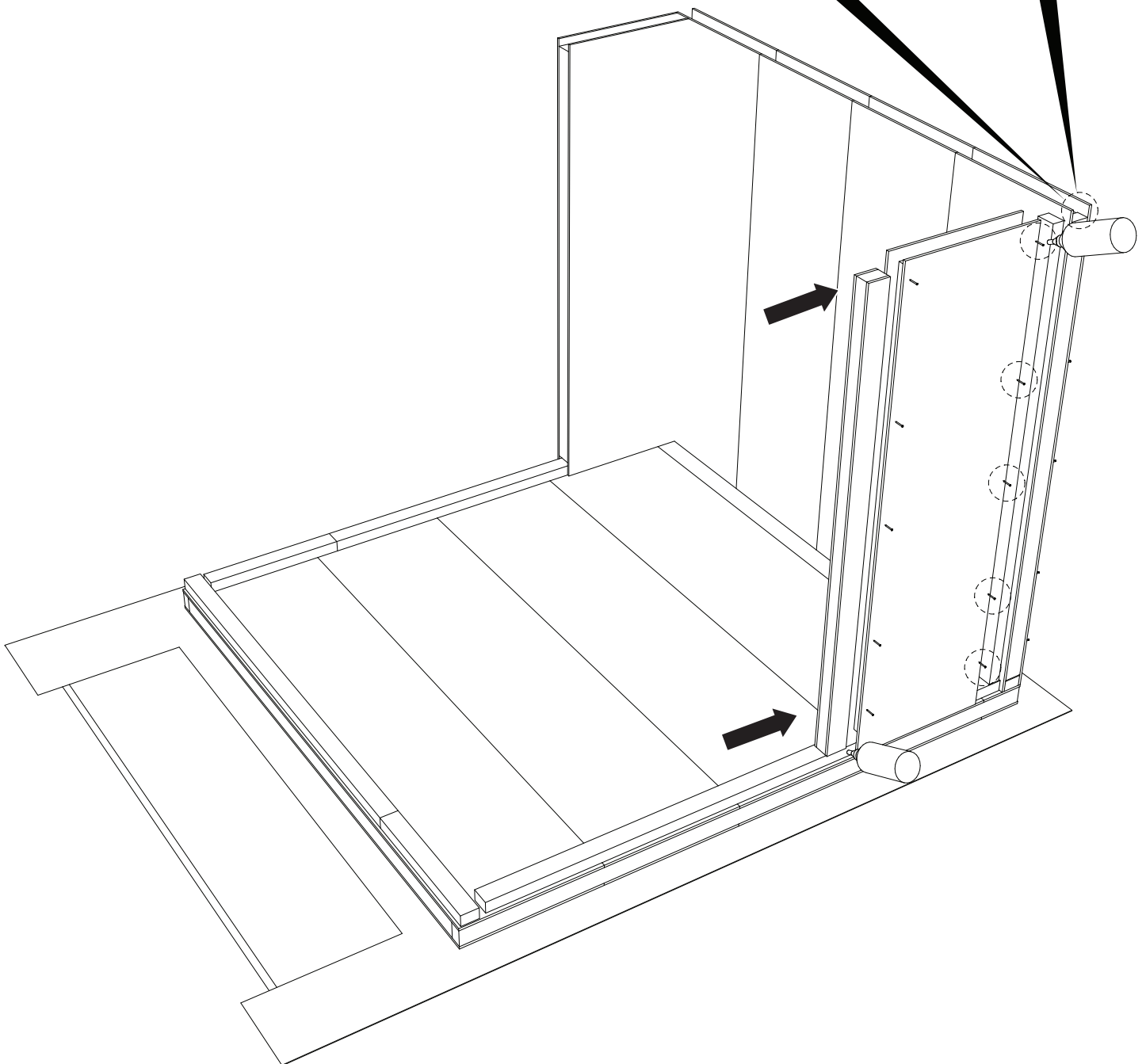
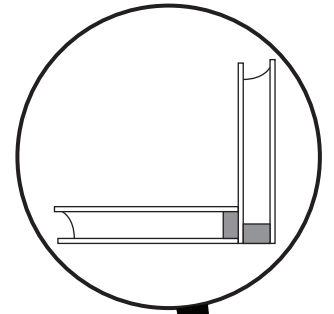

Check for plumb and continue to add panels joining with insulated splines FS When you get to a corner or window add ET secure with S50 screws and glue.

18

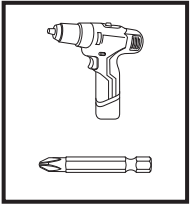

S50

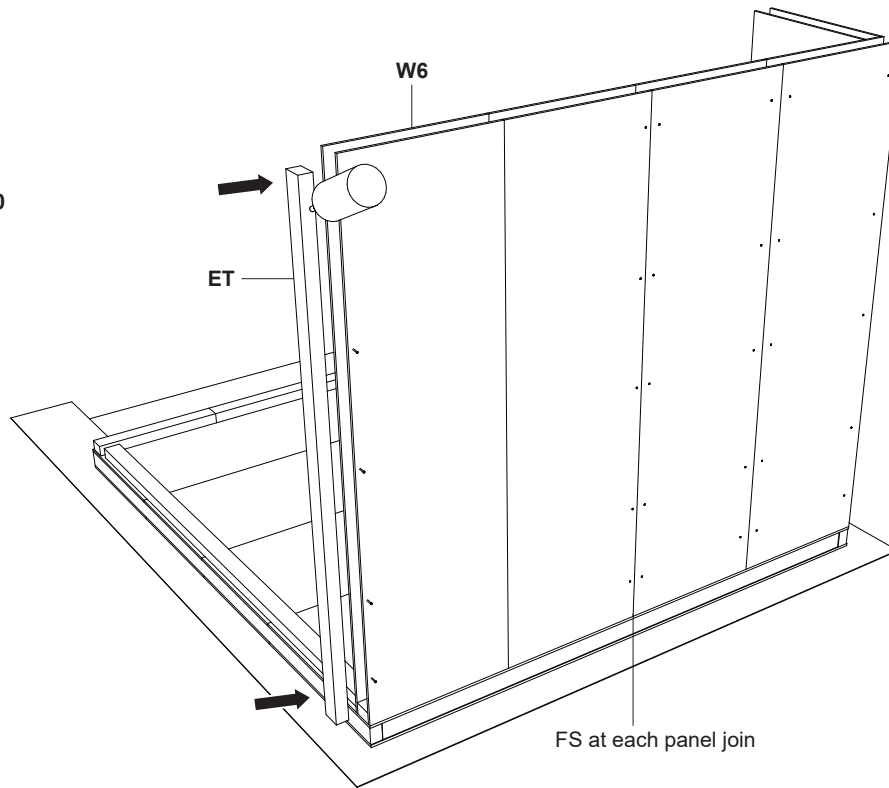

Check for plumb and continue to add panels joining with insulated splines FS add ET corner timber.

NOTE:

- S50 screws
- 150 mm spacing inside and out

19

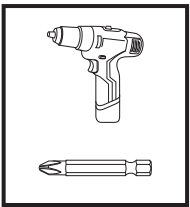

S50

- Glue and screw edges
- S50 screws
 - PU glue

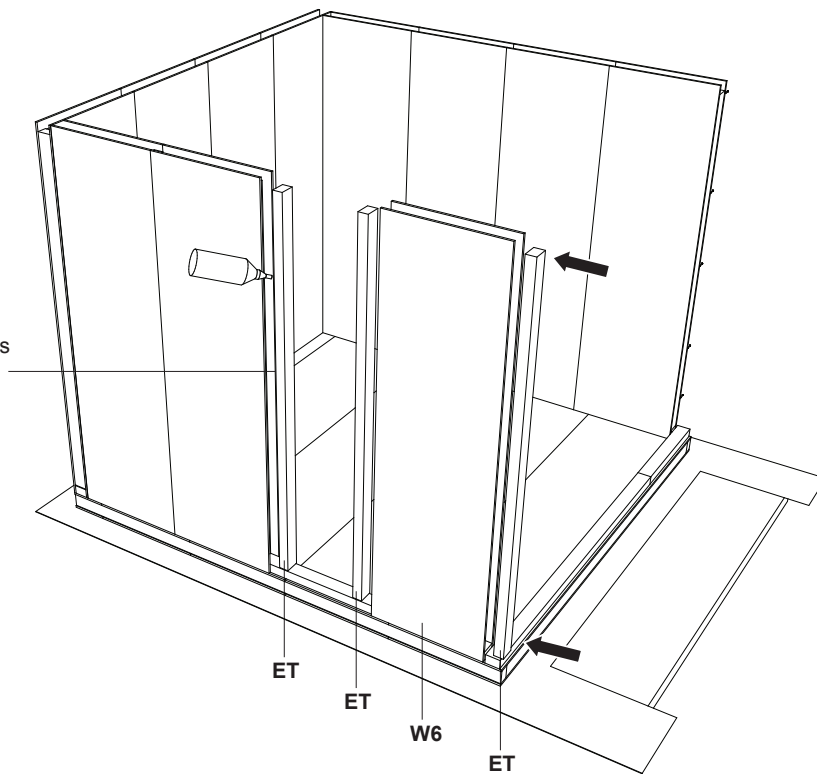

When you get to a desired window or door placement use an edge timber ET.

20

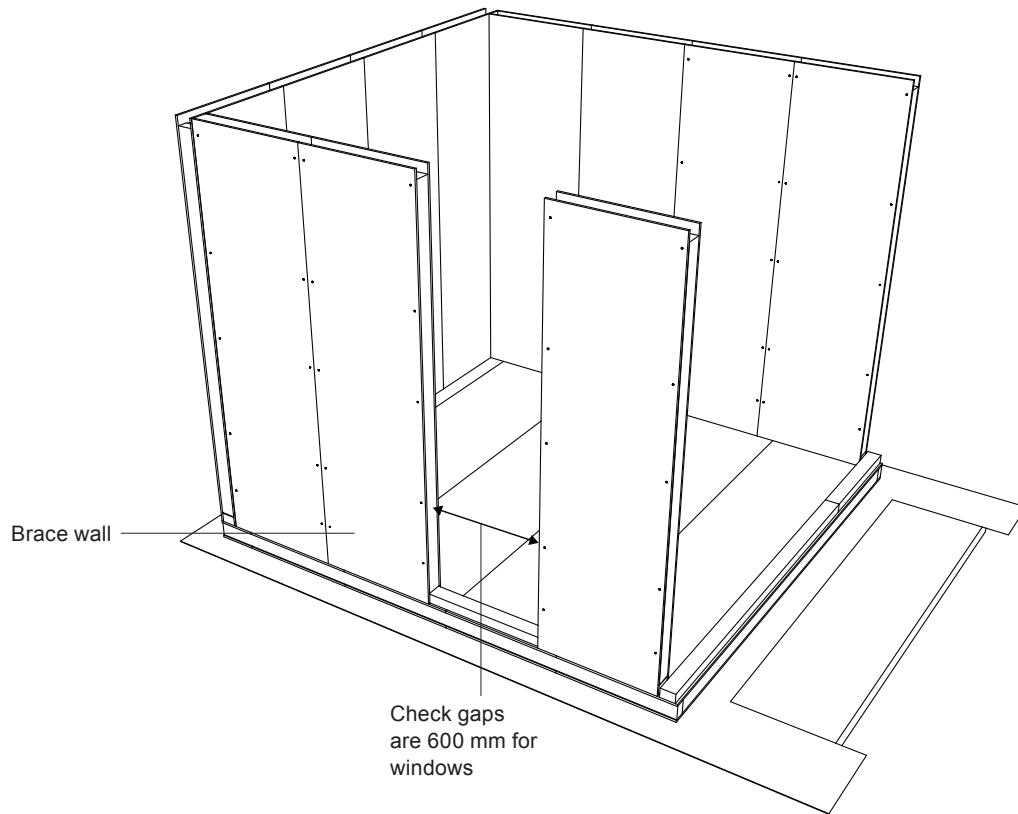

Ensure all freestanding walls are braced as panels could be vulnerable to falling until ring beam is in place.

21

Front wall

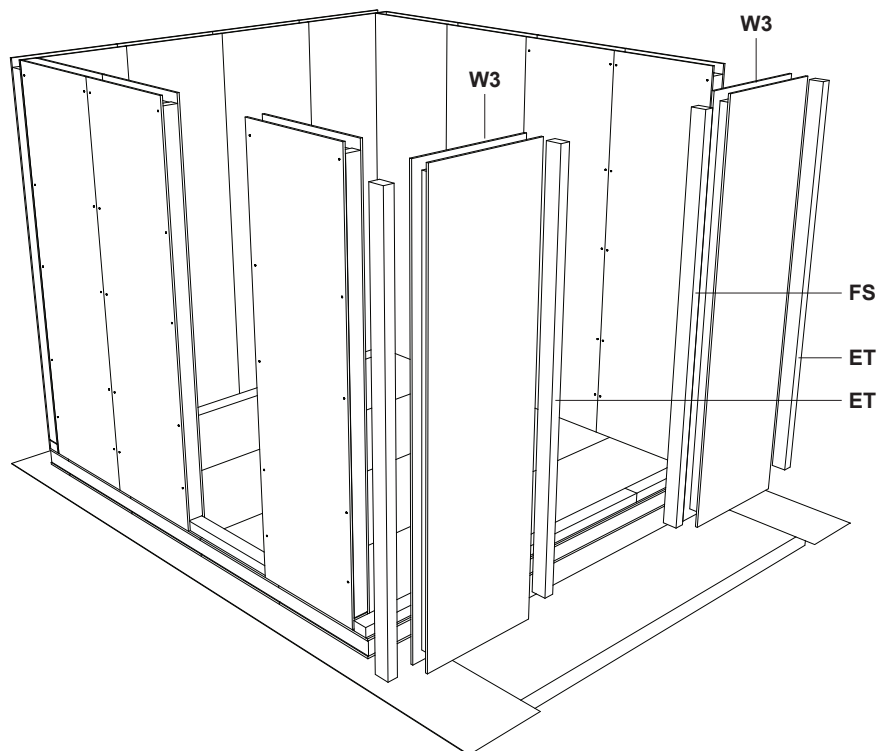

Repeat wall installation steps for smaller door panels. Finish walls with ET edge timbers checking gaps for windows and doors.

22

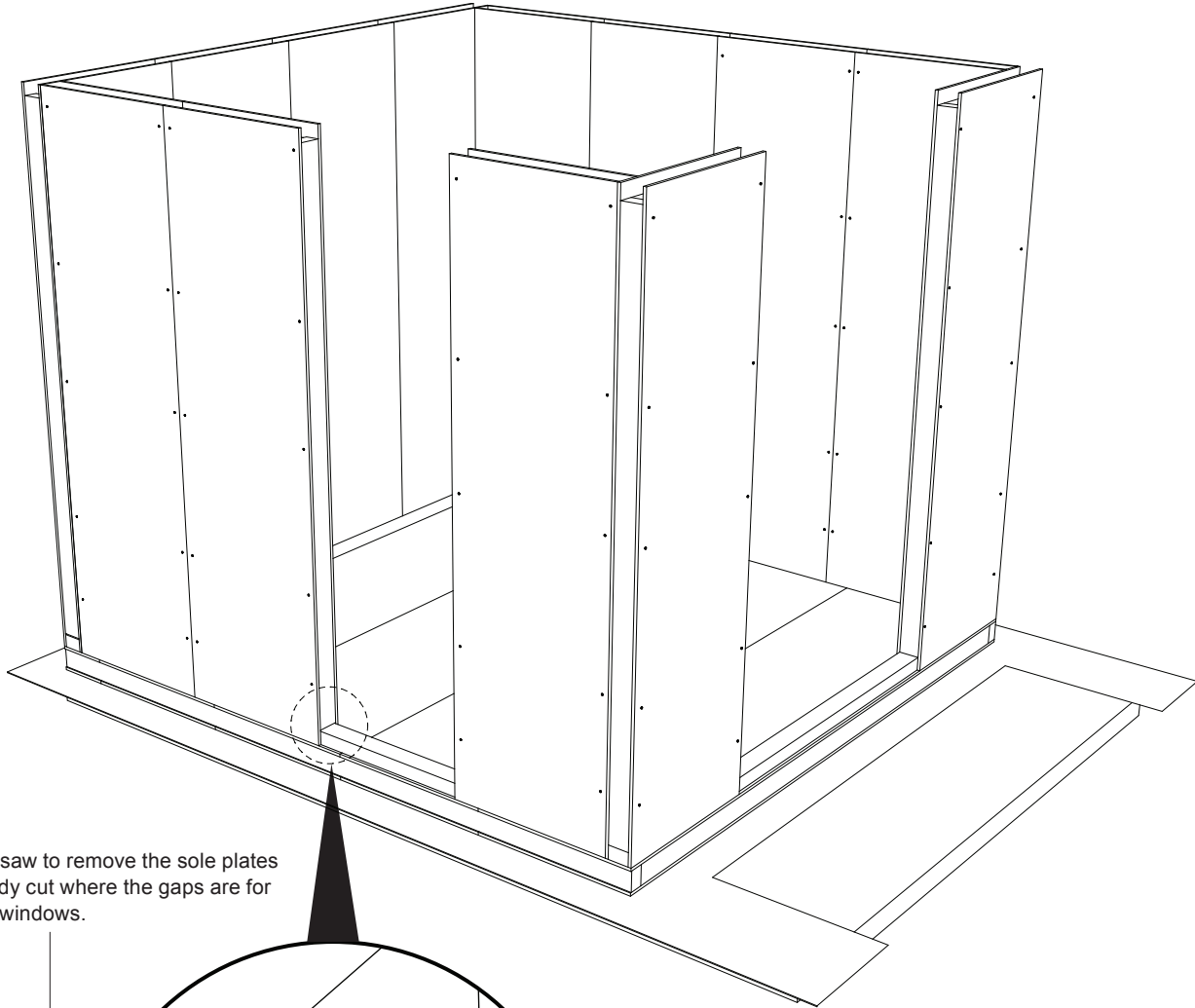
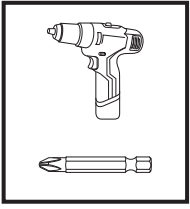

Use panel saw to remove the sole plates if not already cut where the gaps are for doors and windows.

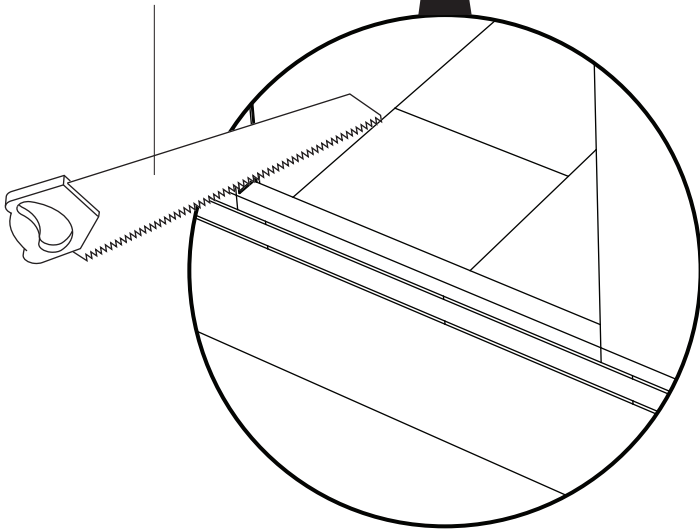

- Check walls are all screwed and glued.
- Check for plumb.
- Ensure all walls are plumb and the apertures for the windows and doors are 600 mm and 1200 mm respectively.

23

Ring beam

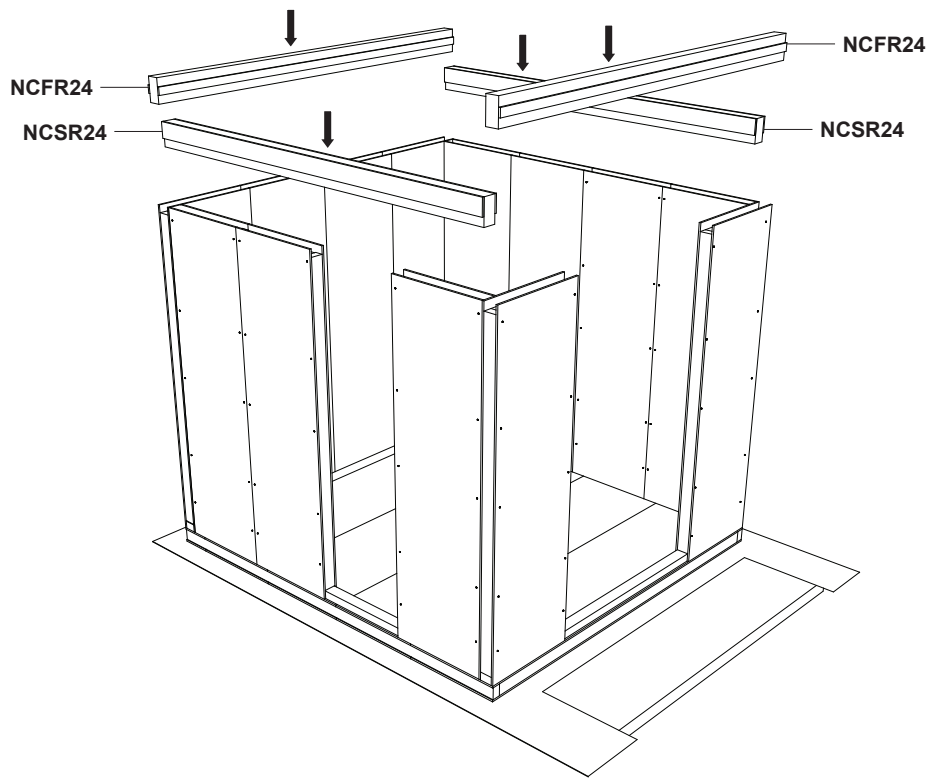

Check top wall panel rebates for any obstructions or debris. Slot beams into the top of walls and fix with PU glue and S50 screws through the top of the SIP panel on both sides. You will need to use a ladder / platform set firmly on the floor or the ground for this part.

24

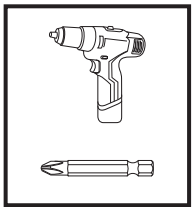

S50

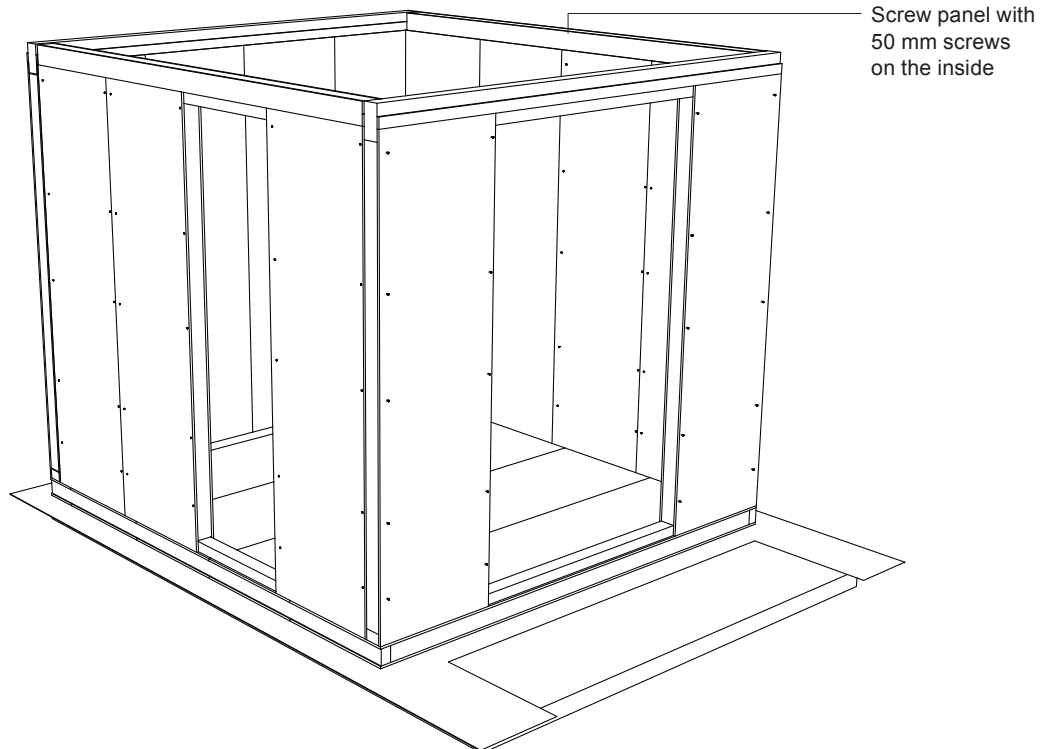

Fix with S50 screws and PU glue. Ensure door and window gaps are the same at the top and bottom.

25

Apex Panels

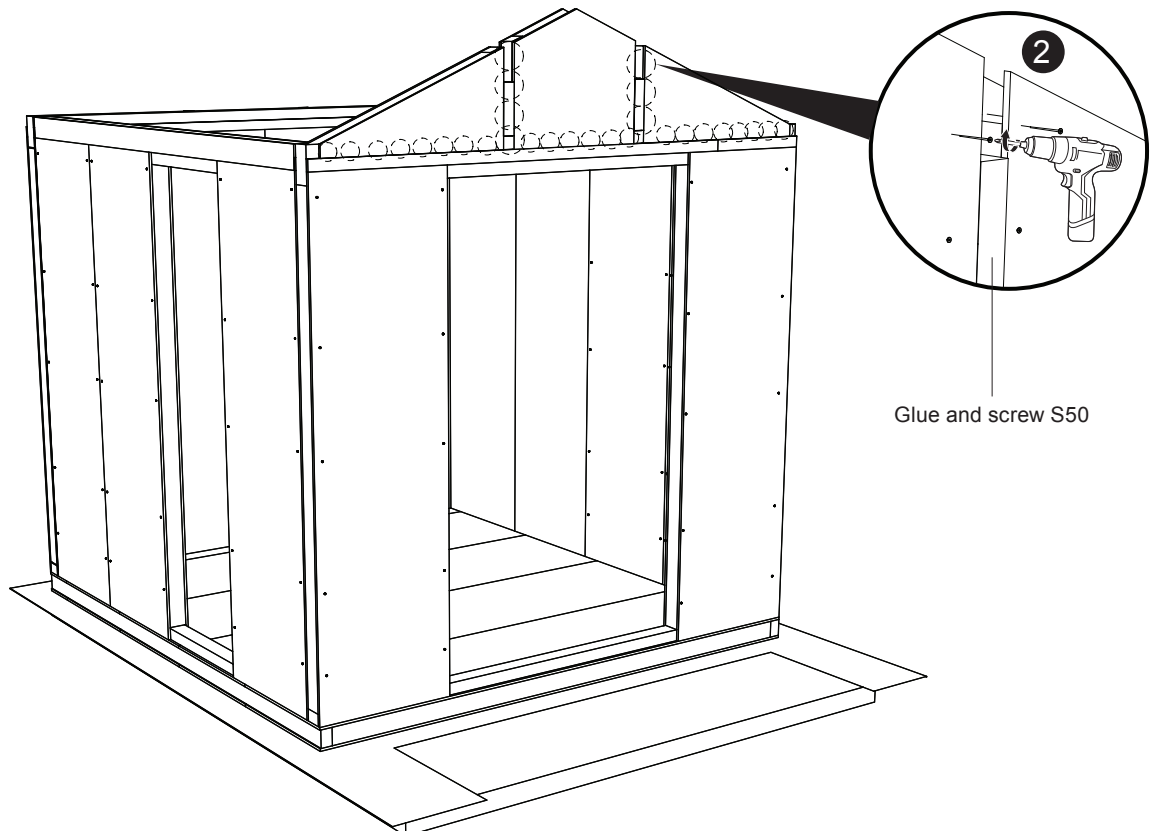
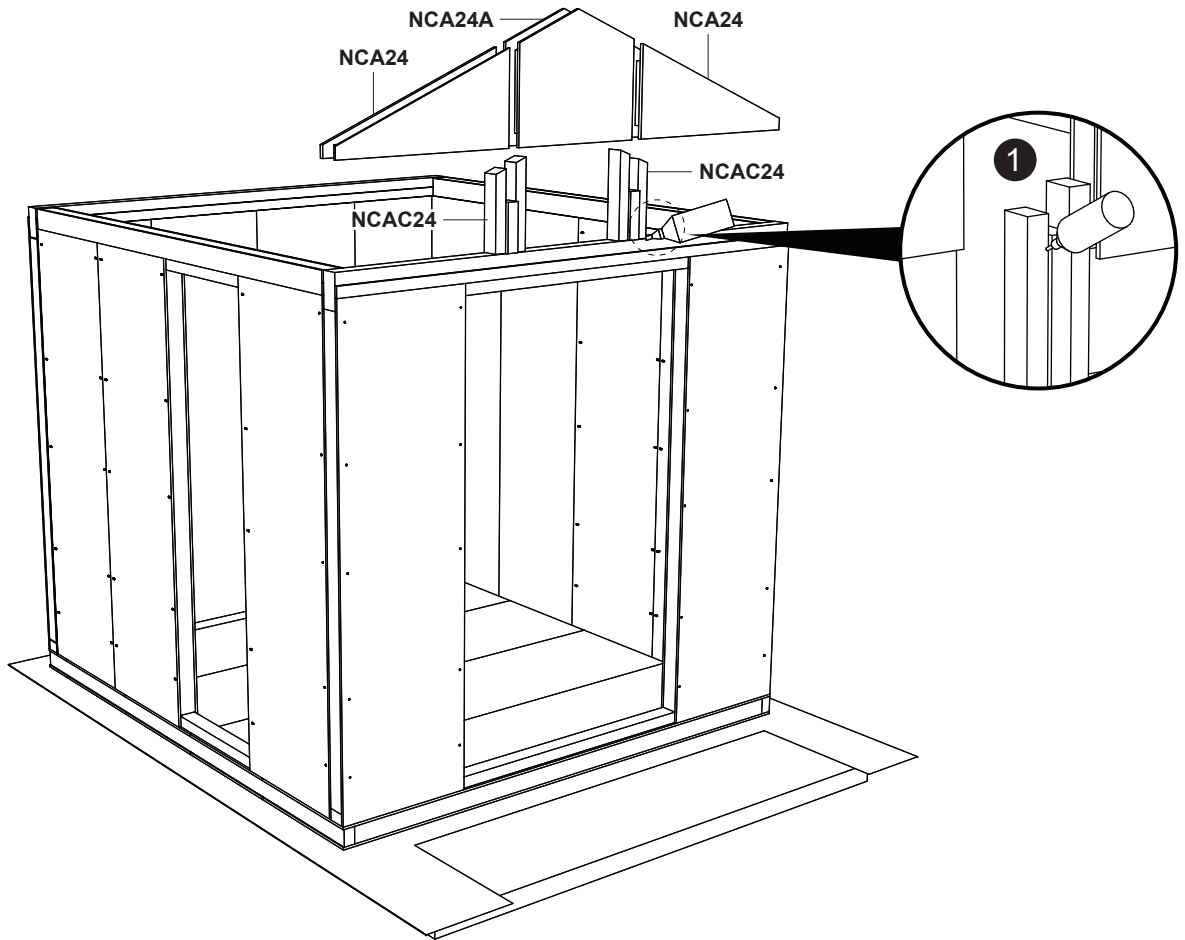

The NCA24A panel sits centrally astride the ring beam. You can start at the back or front. Place it first and then NCAC24 before fixing the NCA24 panel. Fix with S50 screws and PU glue as shown. Repeat the process.

26

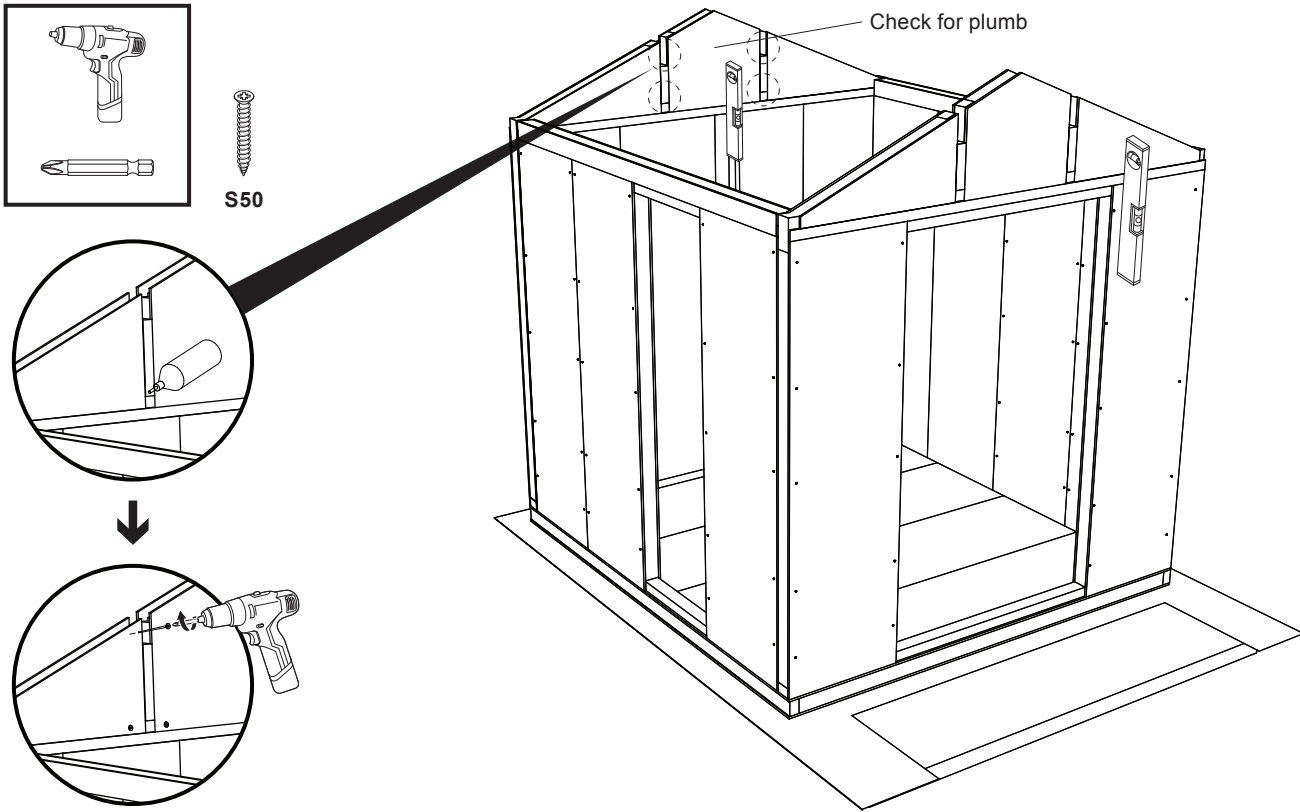

Check for plumb and glue and screw as shown.

27

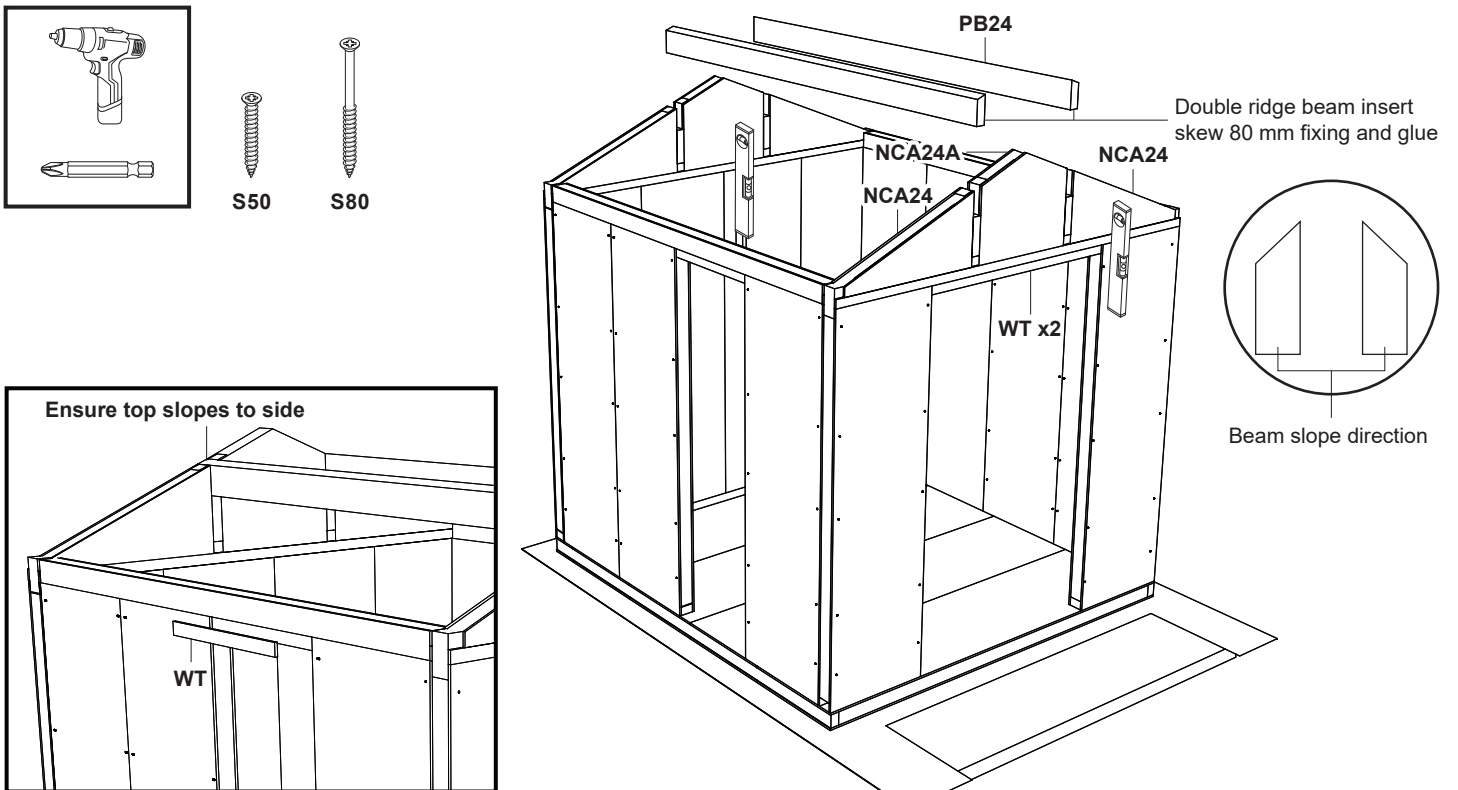

Use a ladder or platform to lift and secure PB24 beams in place as shown.
Fix window and door trims WT inside and out with S50 screws.

28

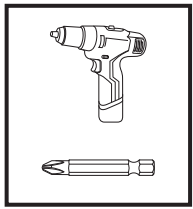

S80

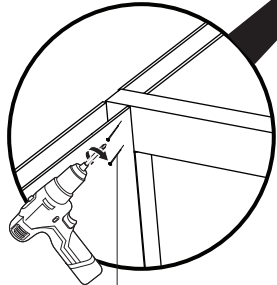

S80 screws

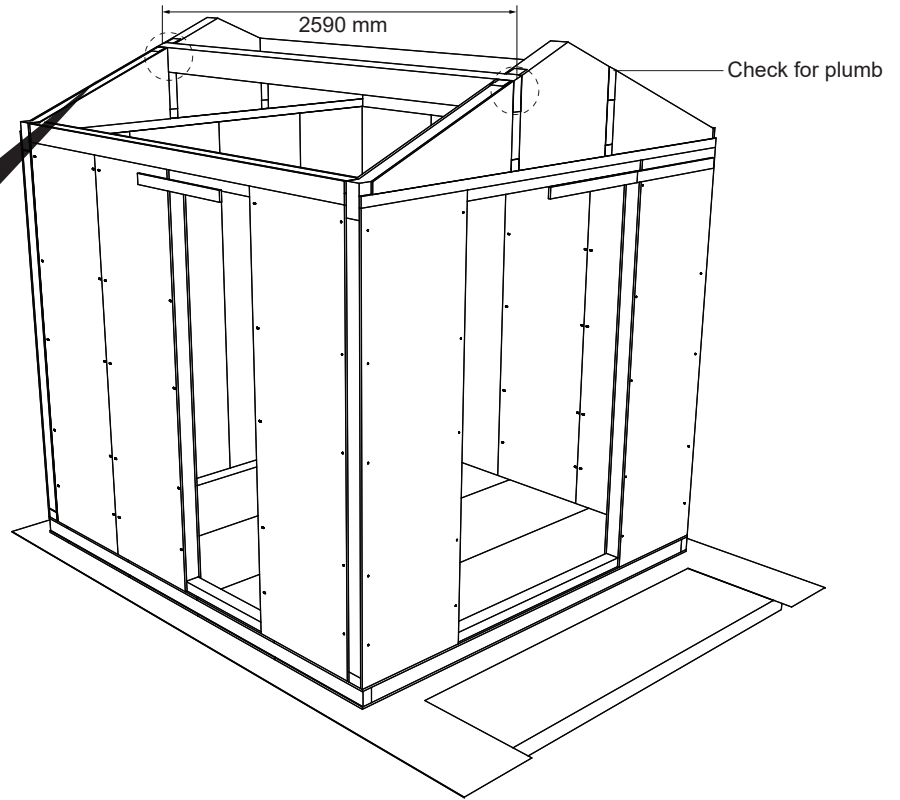

Fix both ridge beams PB24 to roof apex panels by driving screws in at an angle as shown.

29

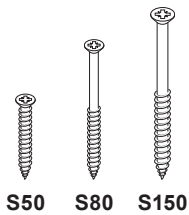
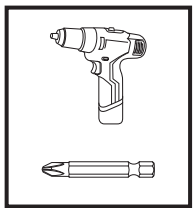

S50 S80 S150

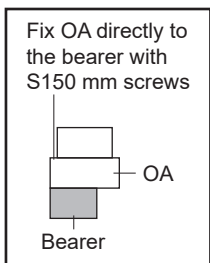

Fix OA directly to the bearer with S150 mm screws

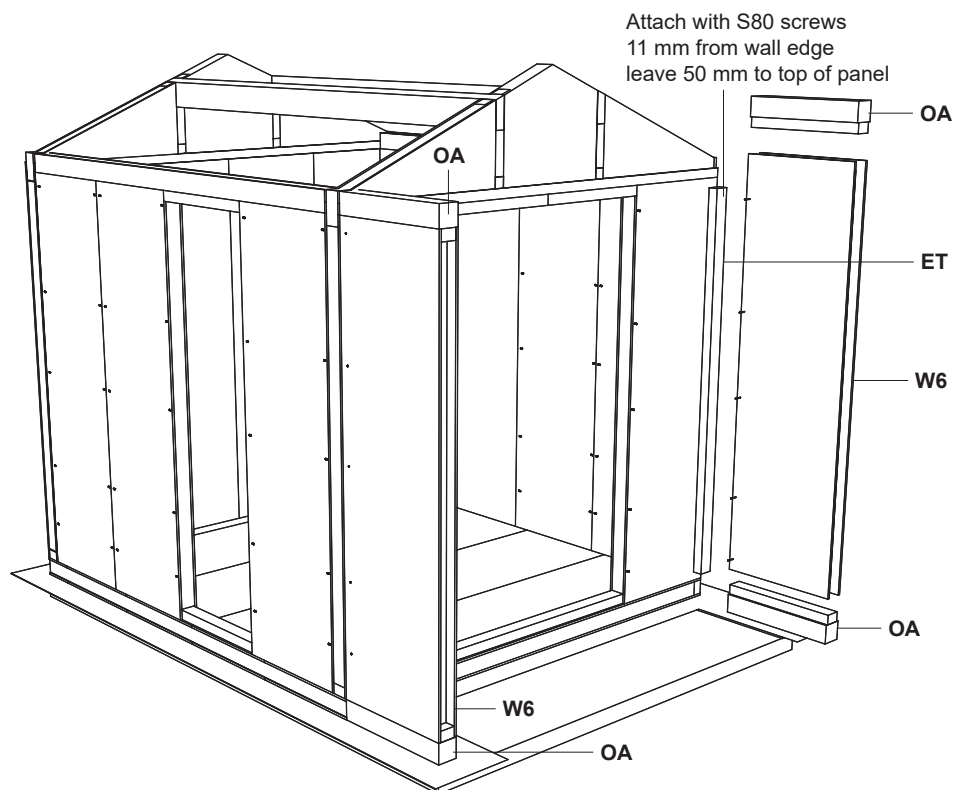

Fix the edge timbers ET as shown and then front side panels with wall plate using S50 screws and glue.

NOTE : If you want to install decking at the front porch you can put the top timber of the OA into the panel and remove bottom slot in W6 panels and secure with S50 screws and glue finish with ET glued and screwed.

30

Roof construction

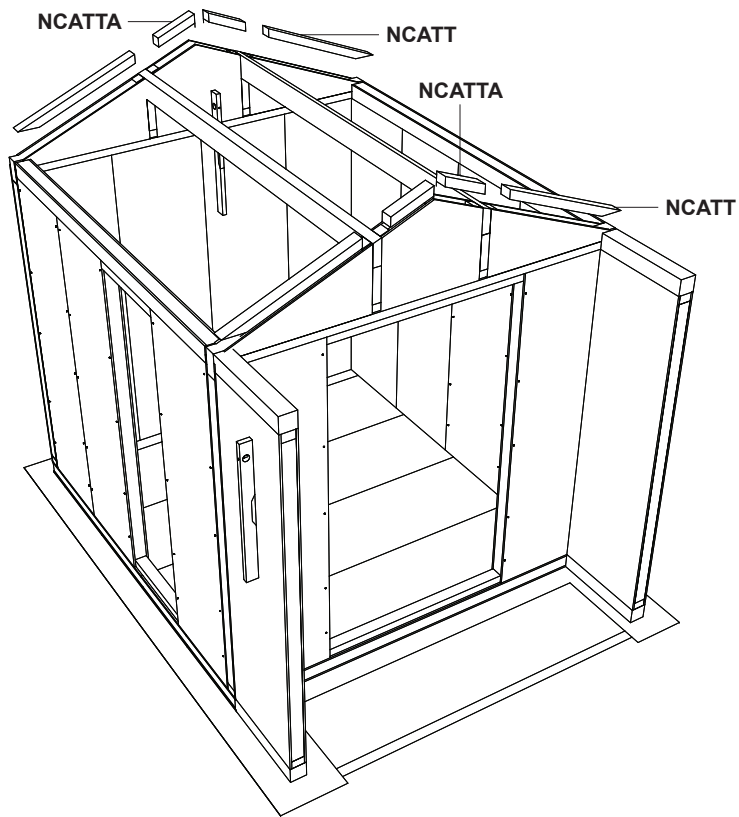
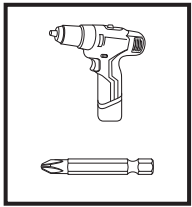

Slot NCATT and NCATTA into top of both apex roof SIP panels. Glue and screw edges with S50 screws and PU glue inside and outside.

31

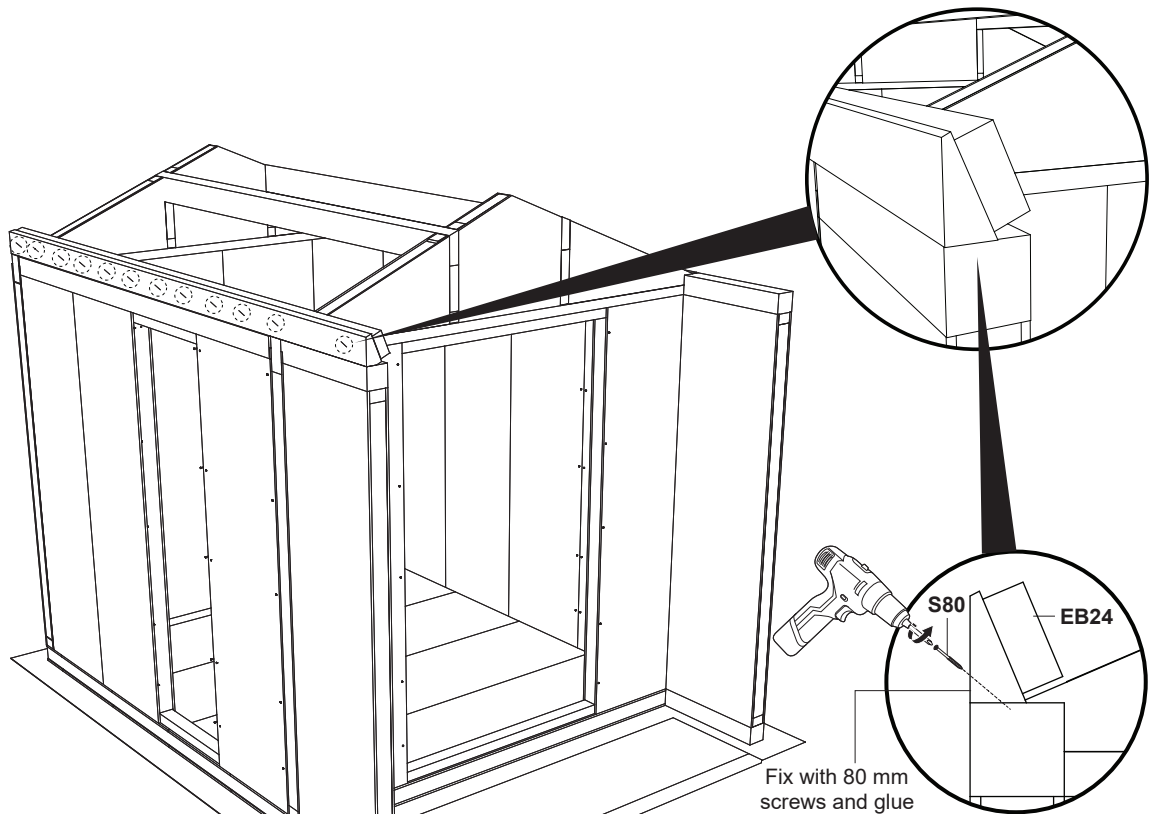
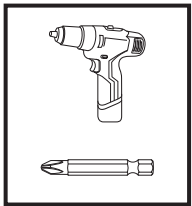

Fix side timber EB24 to wall top using S80 screws and PU glue.

32

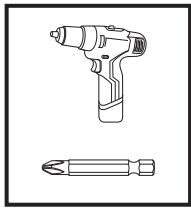

S50

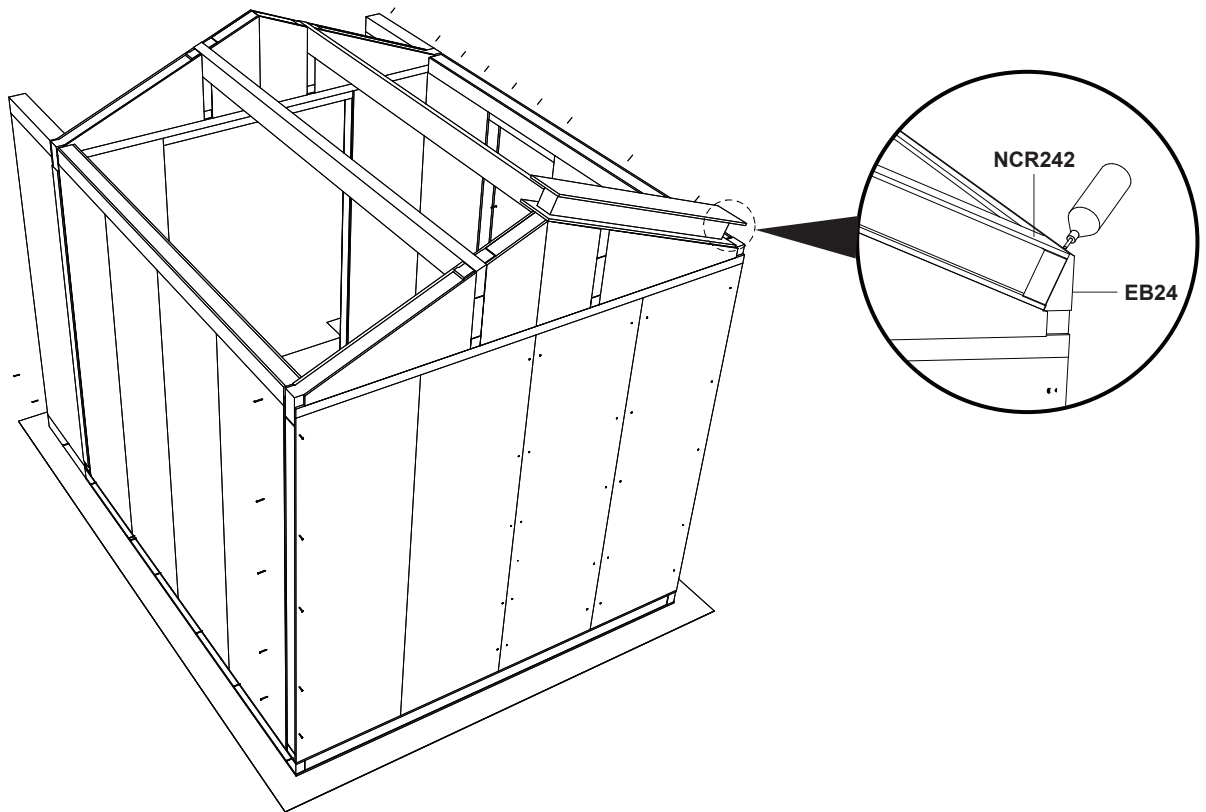

Place the first roof panel NCR242 on top, glue and slot into the edge timber EB24 making sure it is flush with the edge of apex roof panels. Fix up to edge of wall with S50 screws and PU glue. Check for squareness.

33

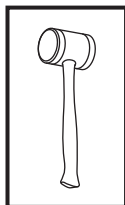
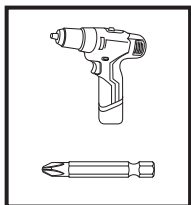

S50

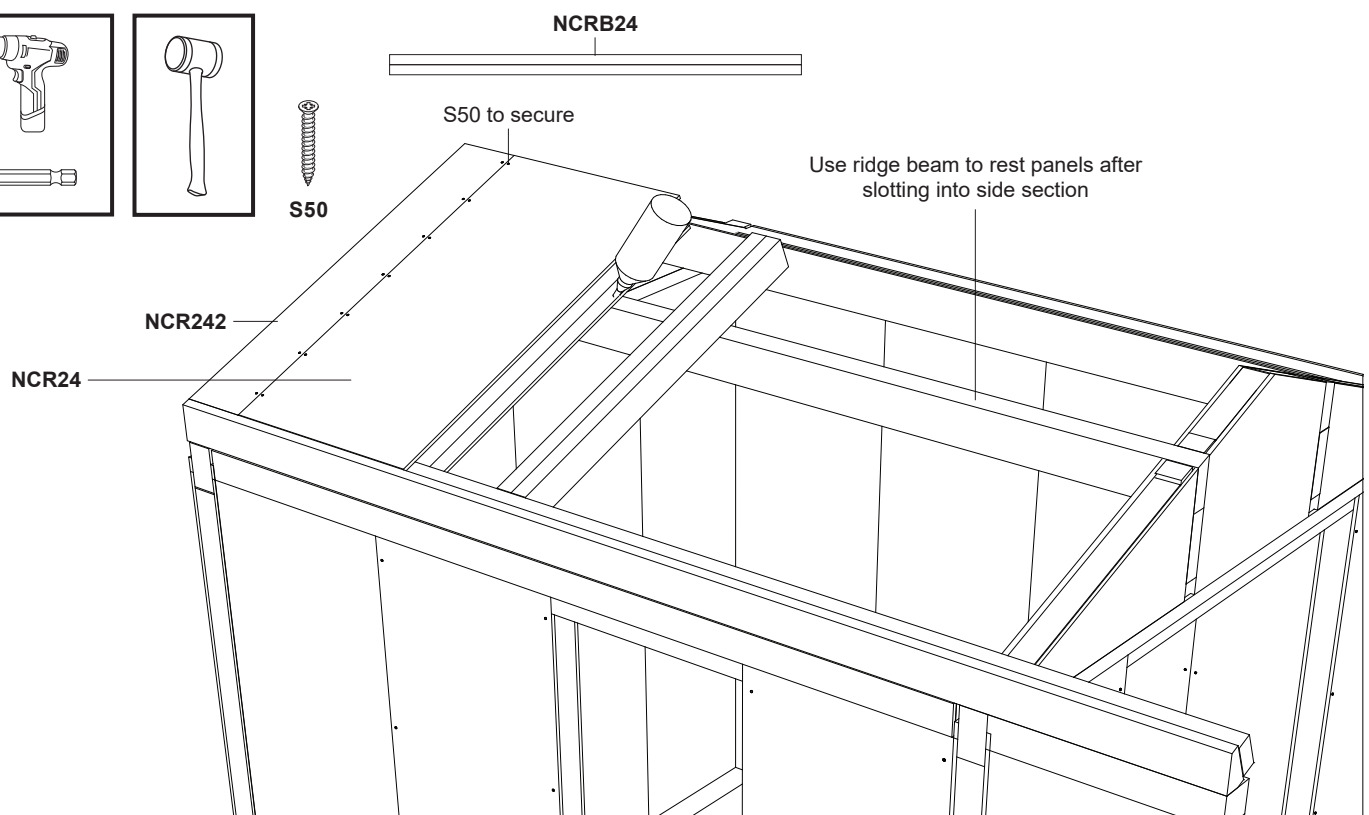

Now glue and slot in roof beam NCRB24 secure in place before fitting the next roof panel NCR24. Apply glue to bottom ledge of roof panel and top of beam surface. Secure with S50 screws inside and out.

34

Centre ridge beam preparation

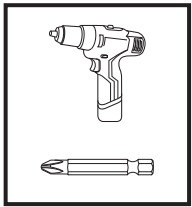

S50

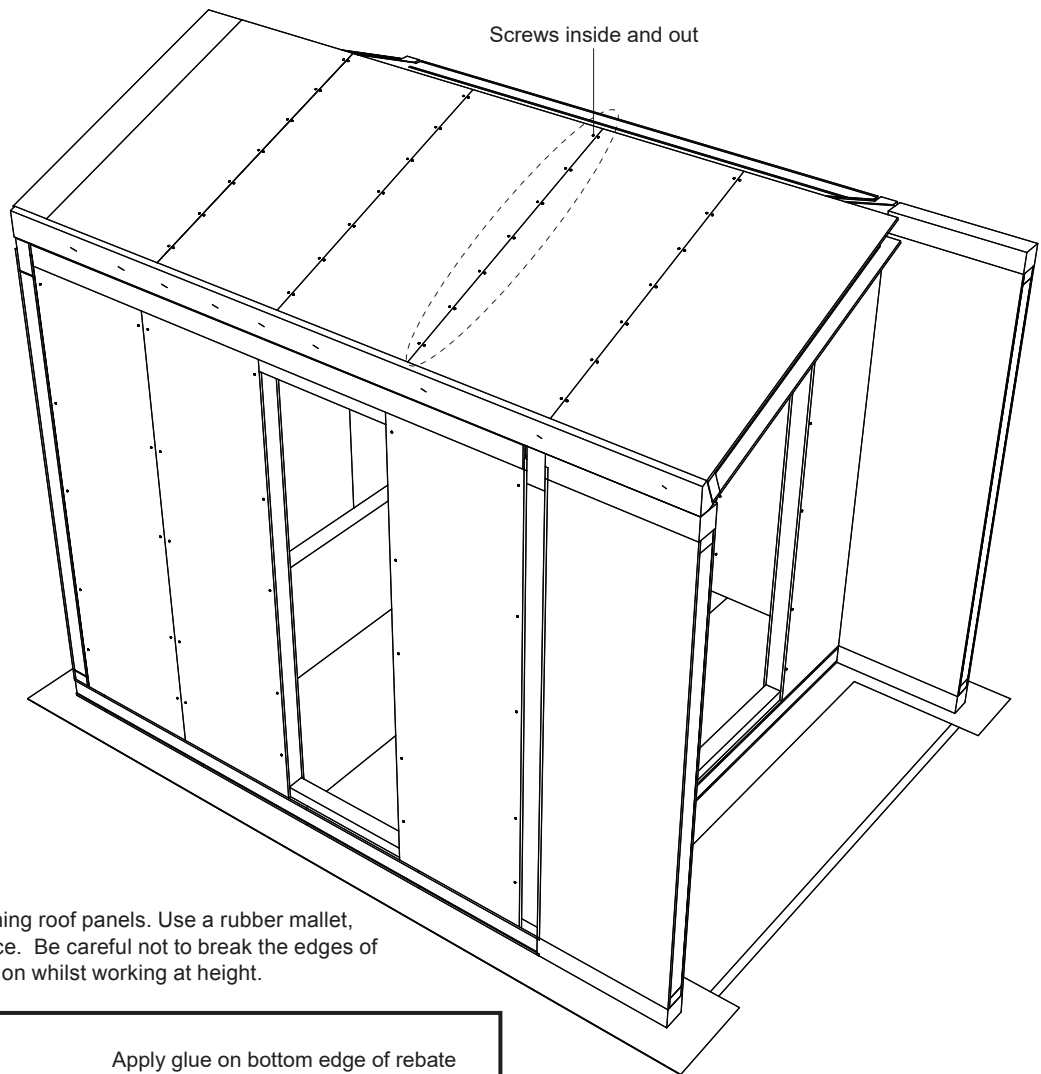

Follow the same steps for remaining roof panels. Use a rubber mallet, if required, to tap panels into place. Be careful not to break the edges of OSB or insulation. Exercise caution whilst working at height.

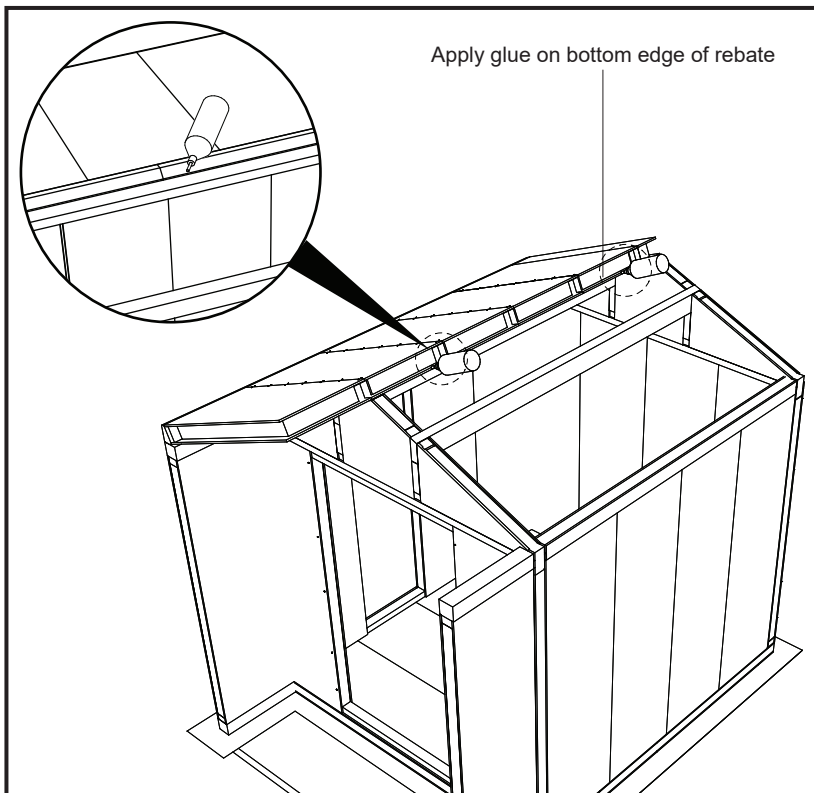

35

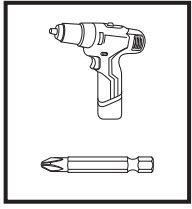

S50

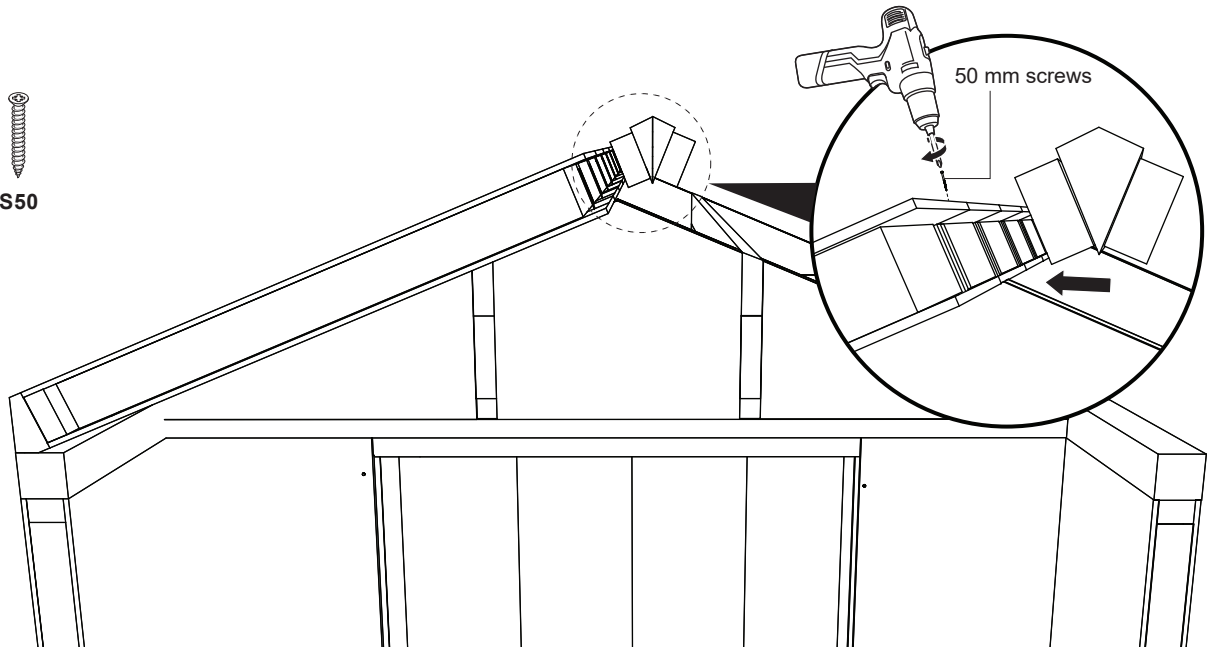

Take special care in this step as it involves lifting the main ridge beam RR24 and working at height. Apply glue to top of the RR24 beam and slot it in the roof panels rebate. You may need to tap the beam into place. Secure by fixing with S50 screws.

36

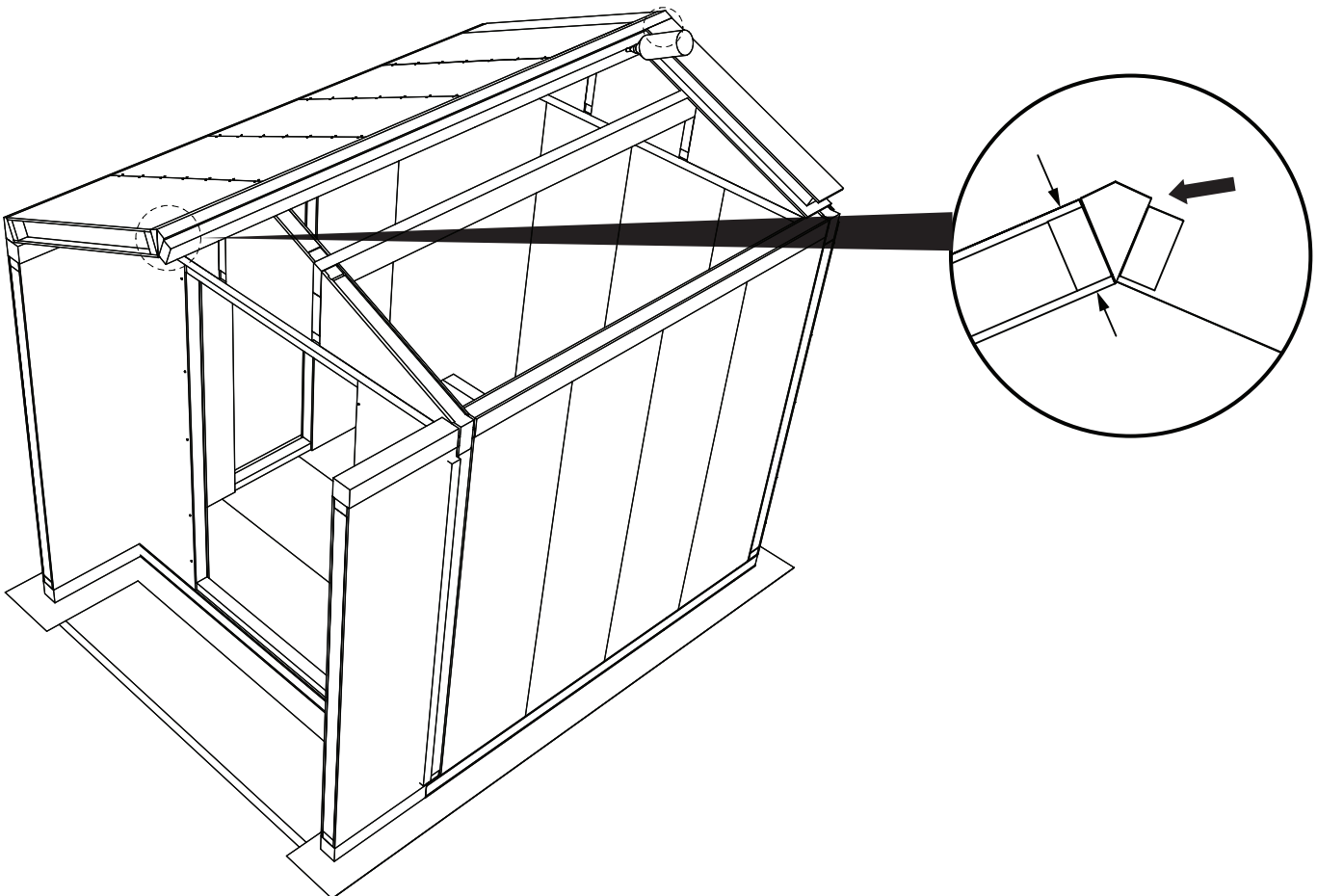

Screw the ridge beam RR24 with S50 screws at 200 mm centres to the top and bottom of the roof panels as shown.

37

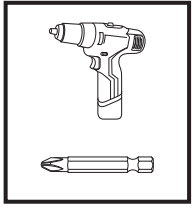

S50

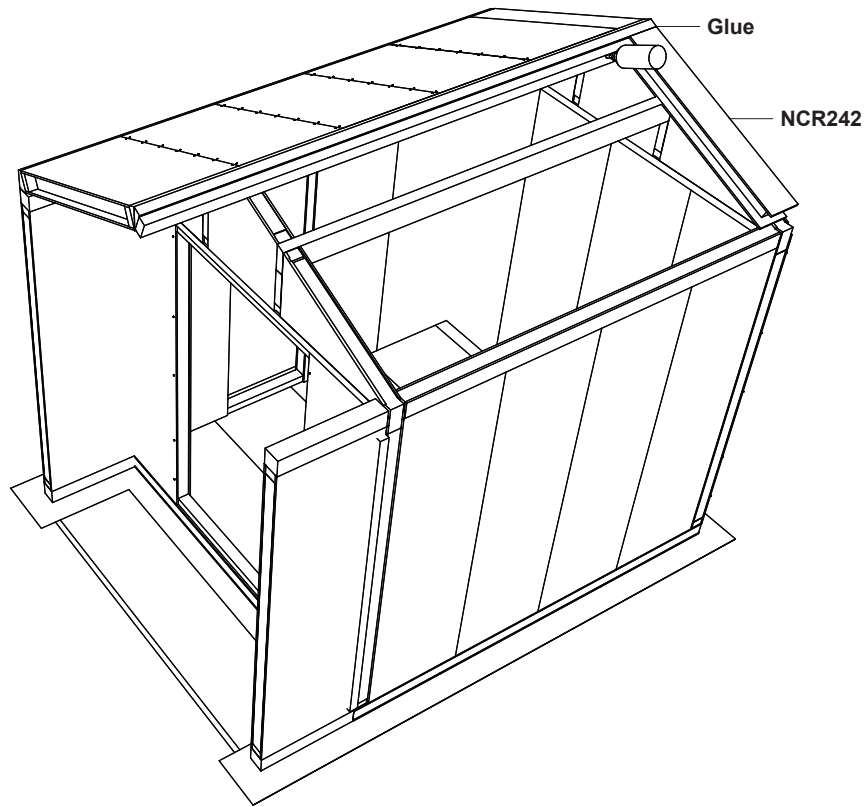

Start second side of the roof with small roof panel NCR242. Glue and slot into the fixed ridge beam RR24 and make sure it is flush with the edge of roof apex panels. Fix up to edge of wall with S50 screws and PU glue. Once the beam RR24 is fixed begin to add panels to rest of roof. Remember to glue each panel to RR24.

38

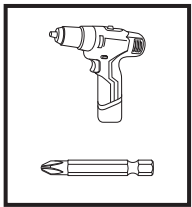

S50

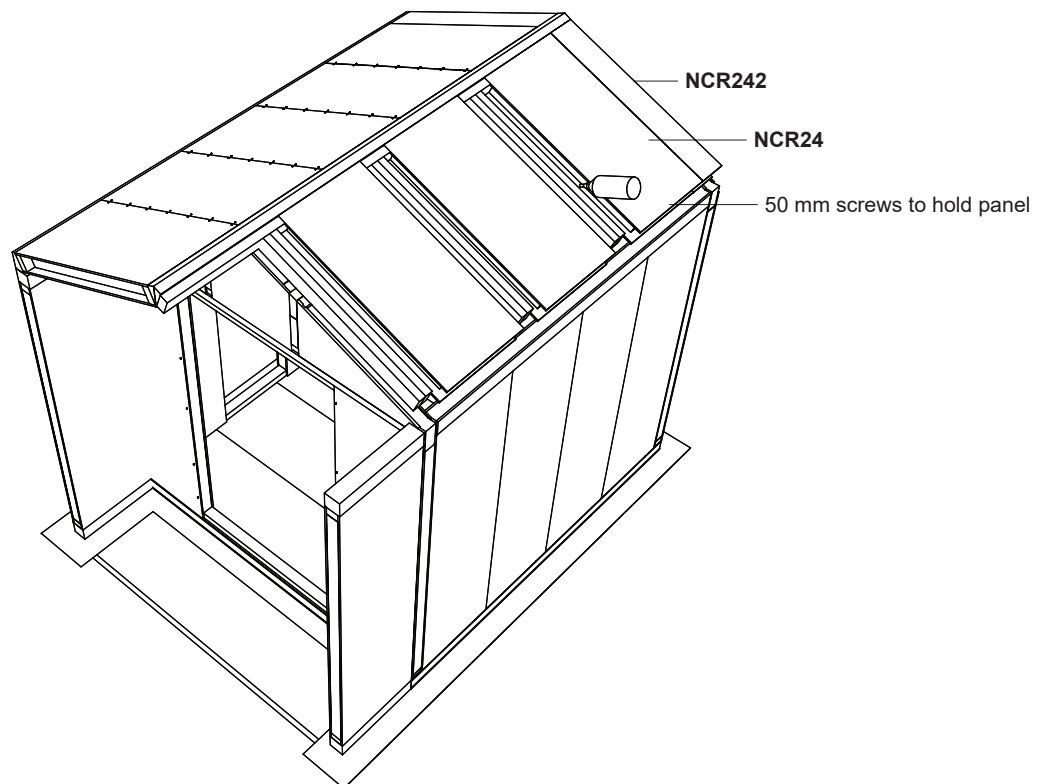

Continue to construct roof slotting panel up into ridge timber and fixing with NCRB24 roof beams.

39

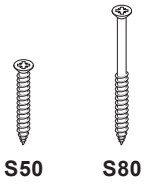
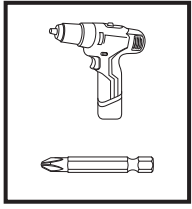

S50

S80

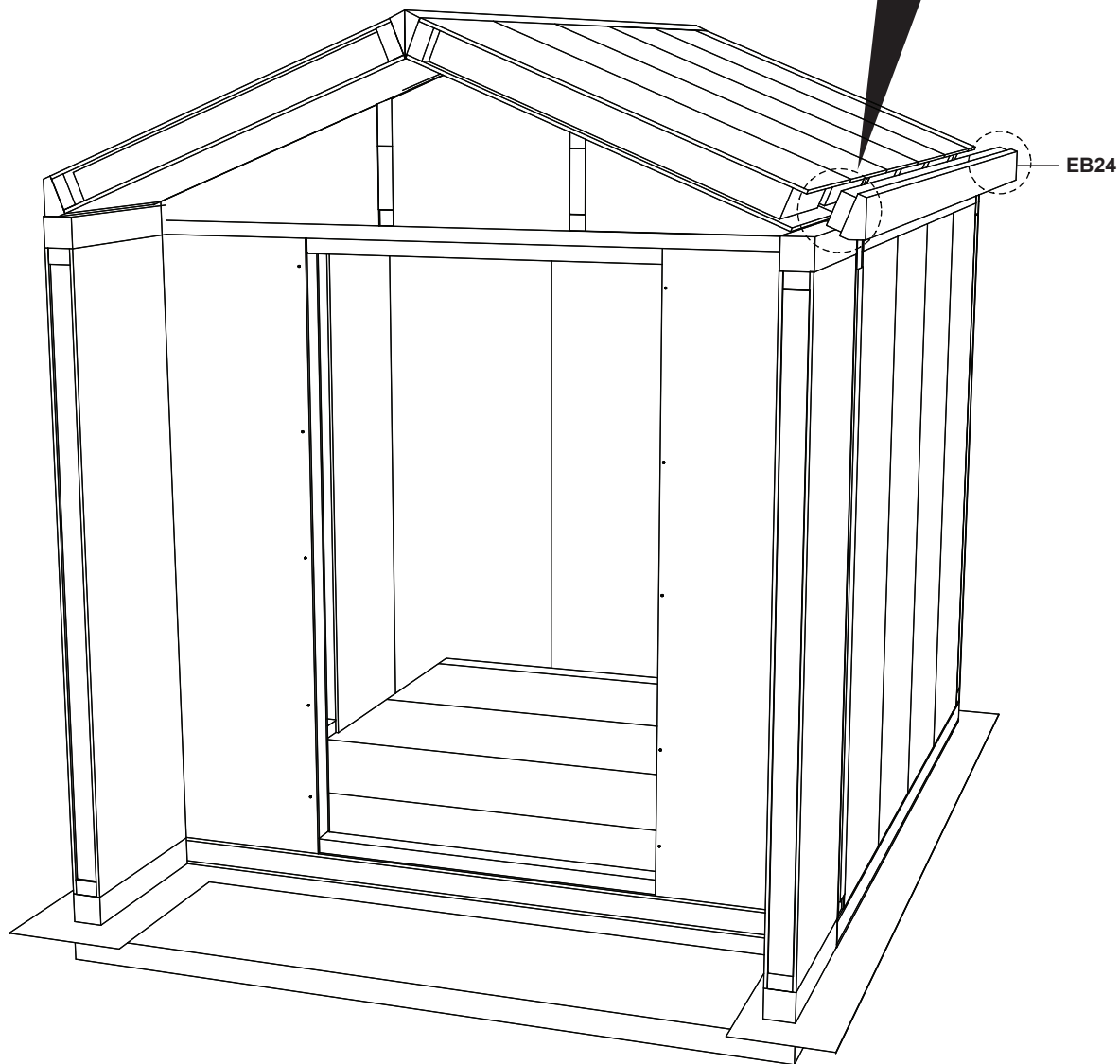
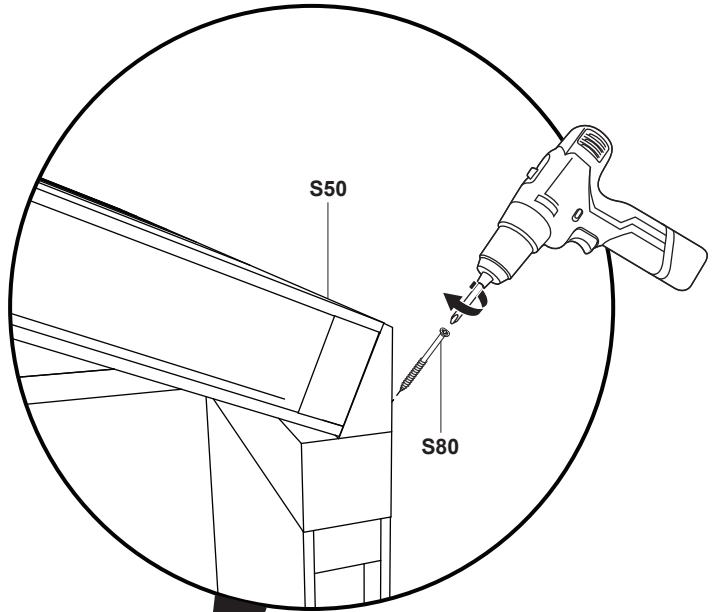

Once all the roof panels are fixed in position, the second side timber EB24 can be glued, slotted in and screwed with S80 screws.

40

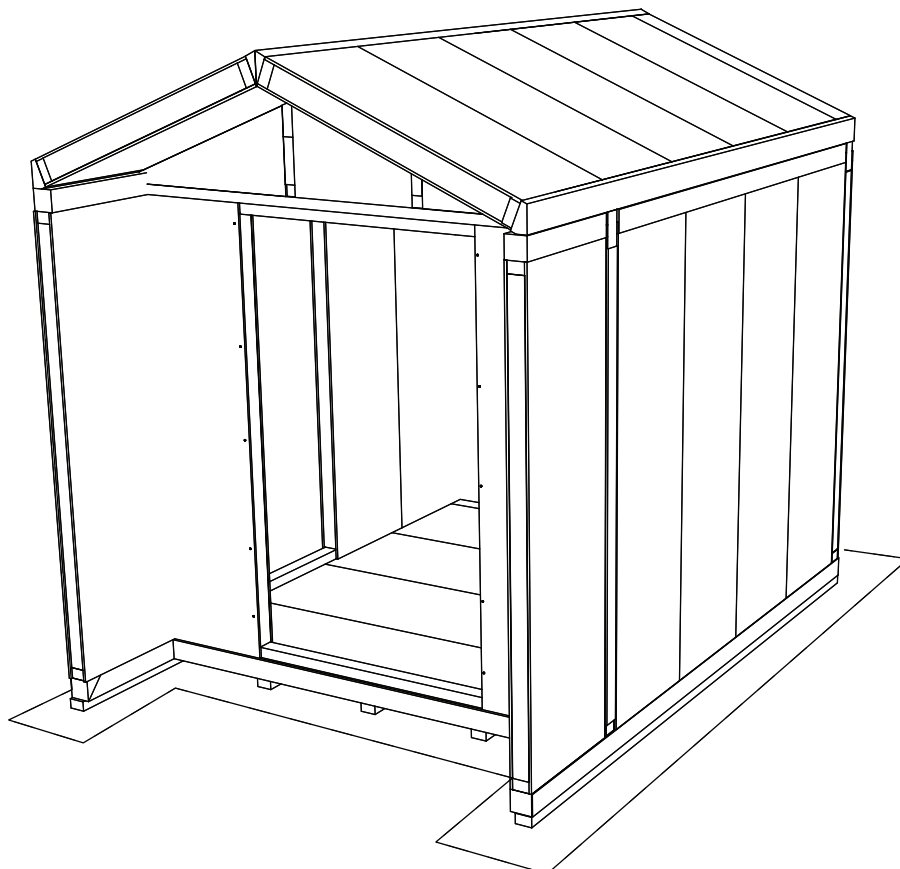
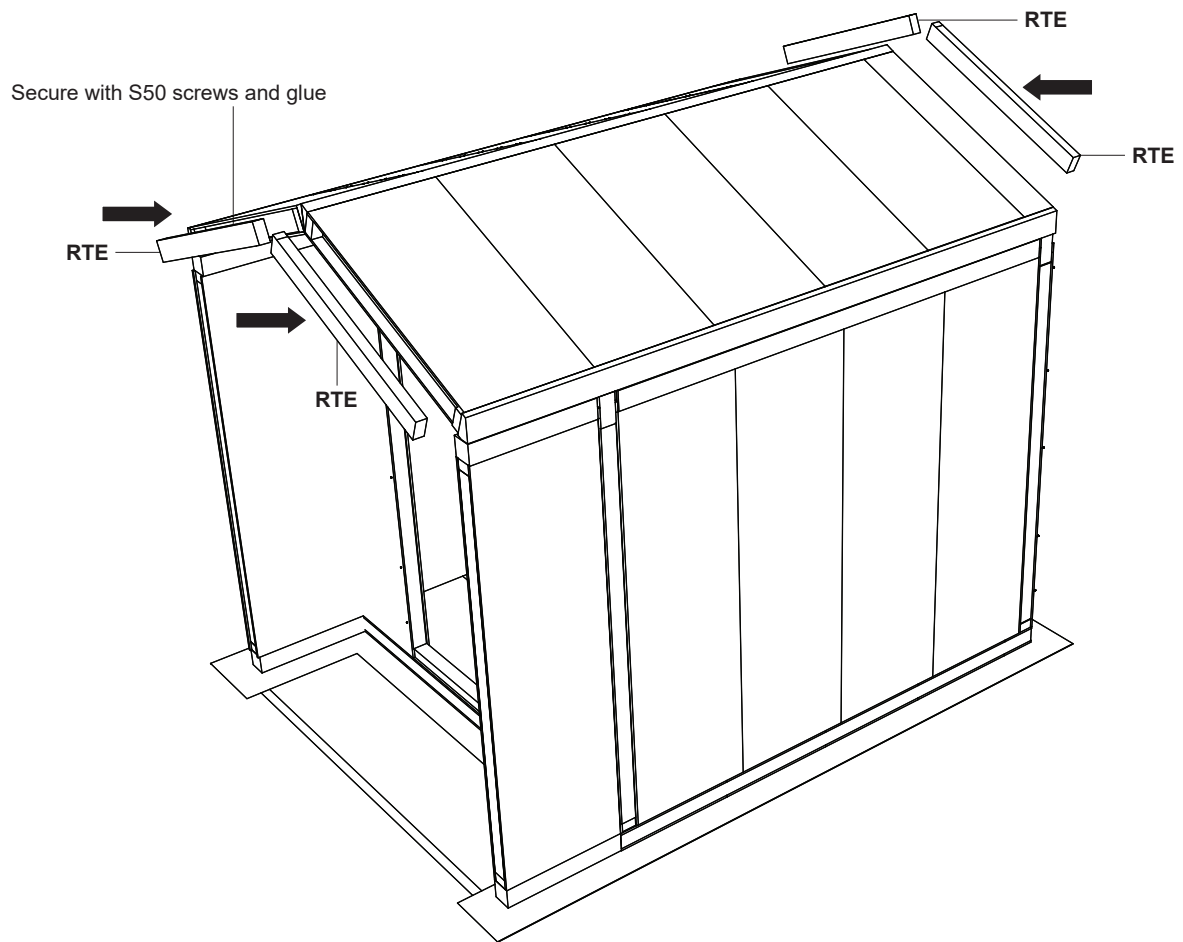

Glue, slot in and fix roof edge timbers RTE to front and back of the building using S50 screws.

41

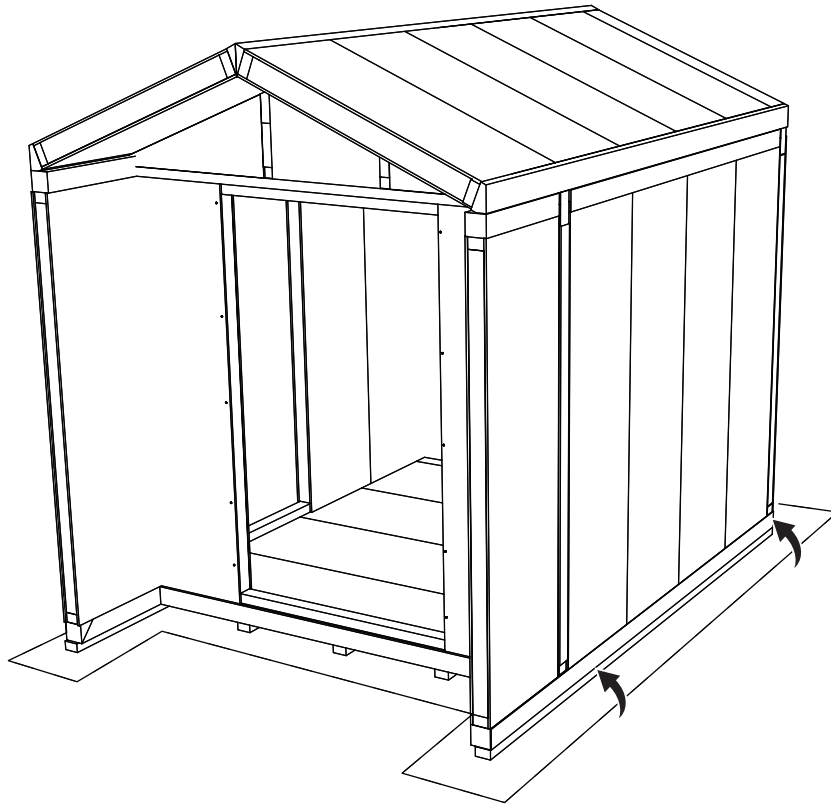

Fold up the DPM and staple to the building fold at corners and trim off excess.

42

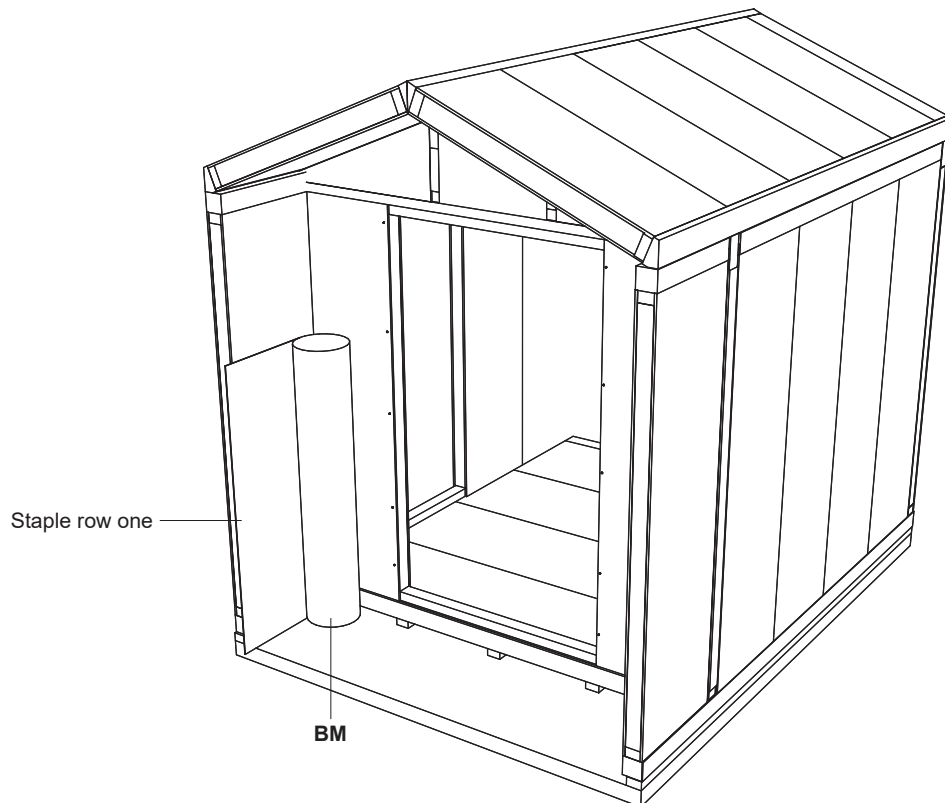
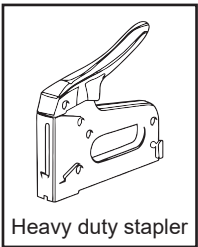

Starting from the bottom corner with slight overlap on the DPM, complete full wrap covering door and windows, stapling the top, middle and bottom of the breathable membrane sheet.

43

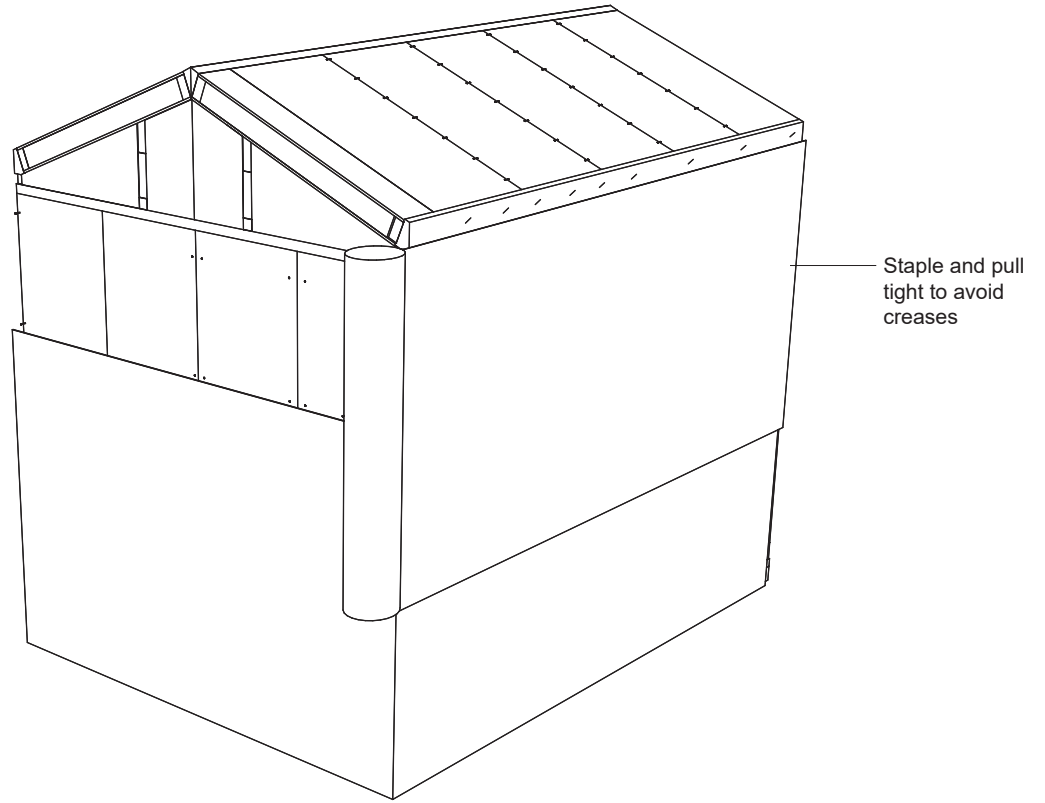
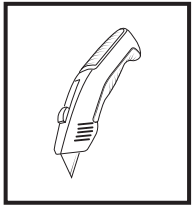
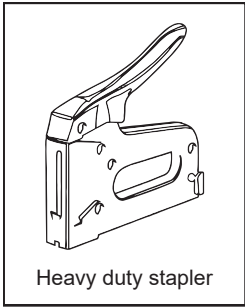

Once you have overlapped the starting point, cut off the excess and staple the end into place. Start second wrap overlapping the first (use marking on wrap).

44

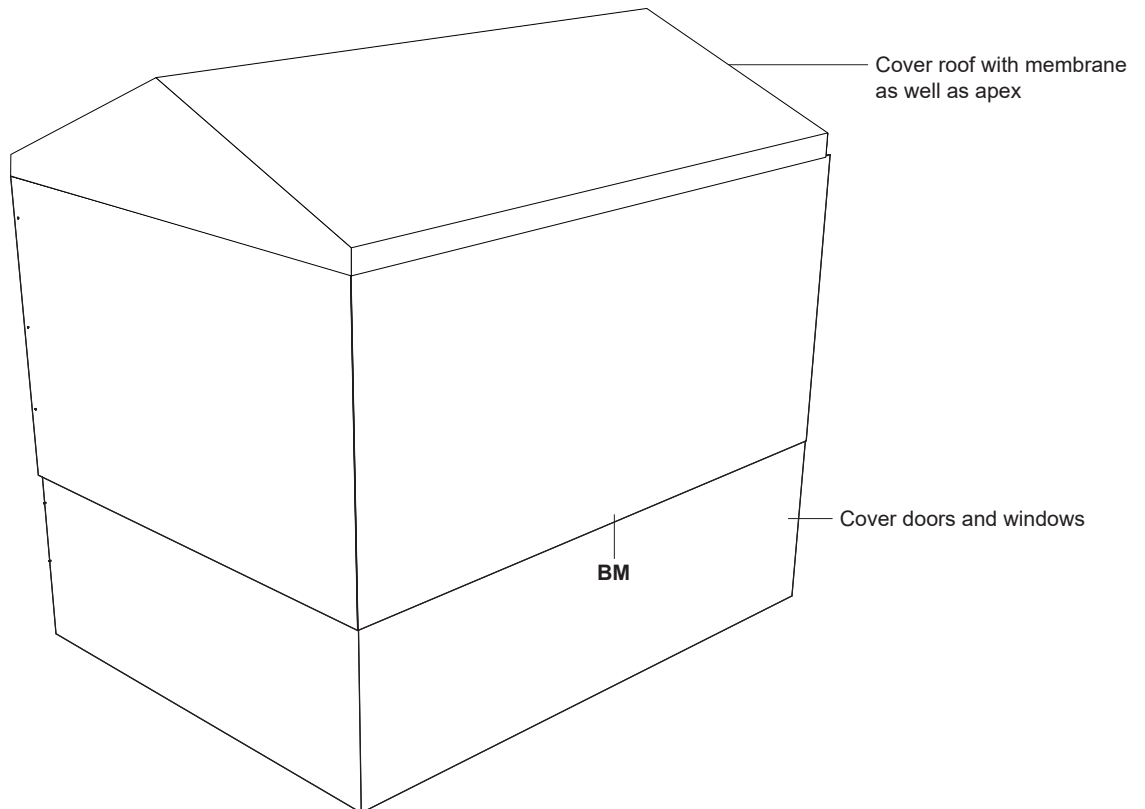

Complete roof and apex wrap.

45

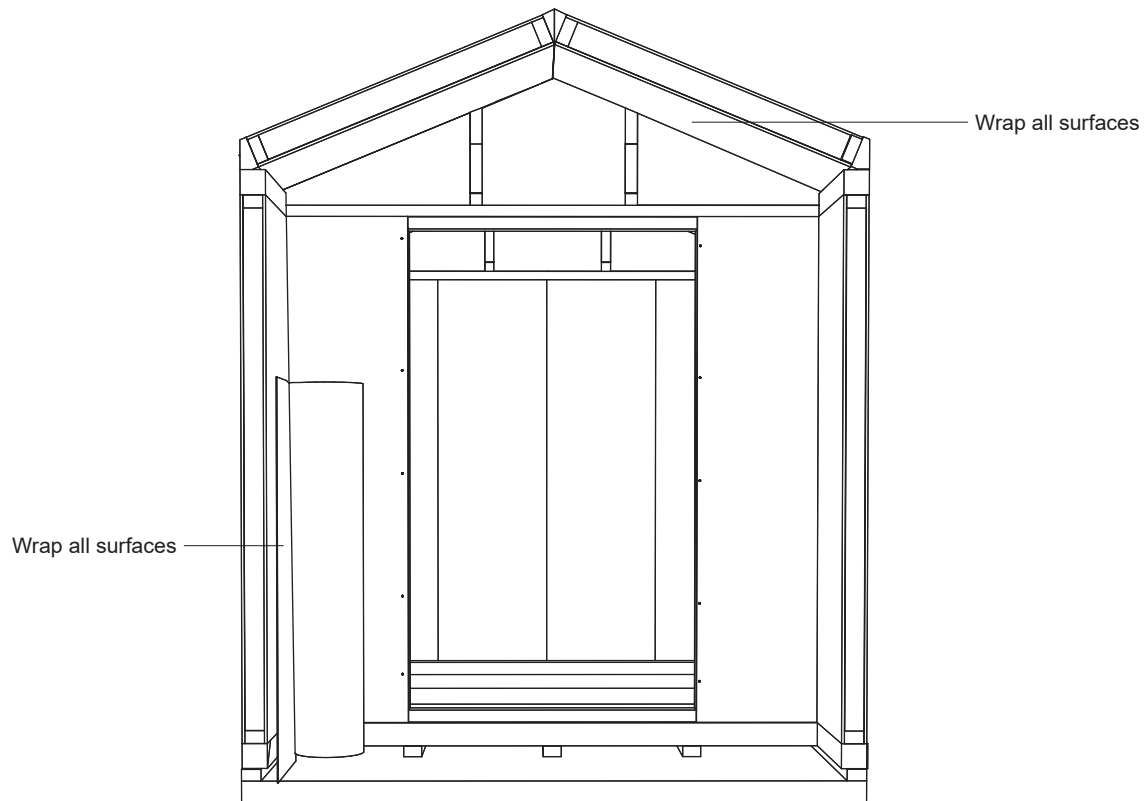

46

Membrane around windows and doors

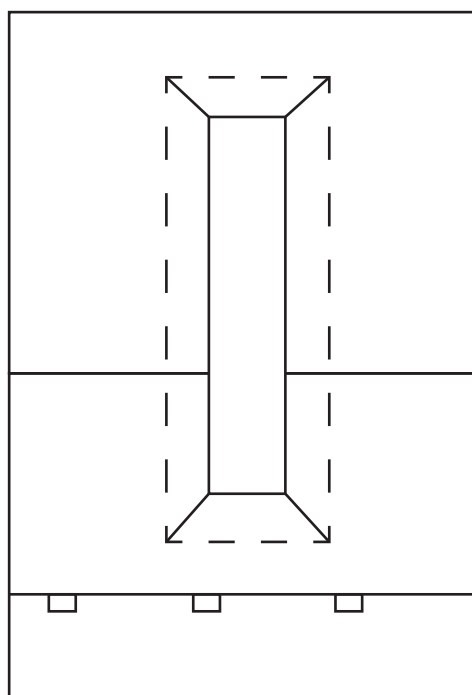
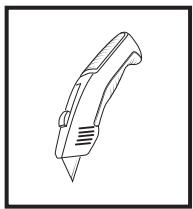

Cut 45 degree angles at corners and leave 100 mm of wrap to fold into the door or window.

47

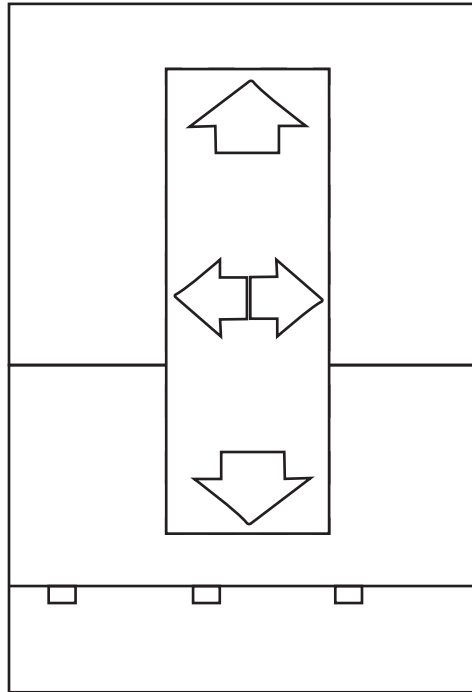
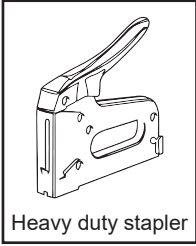

Fold membrane around corner and staple.

48

External paneling

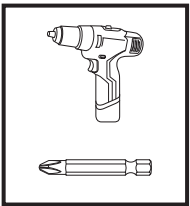

- Fix panels adjacent to the windows first.
- Corner planks are applied last.

- Tongue and groove, ensure panels are a tight fit.

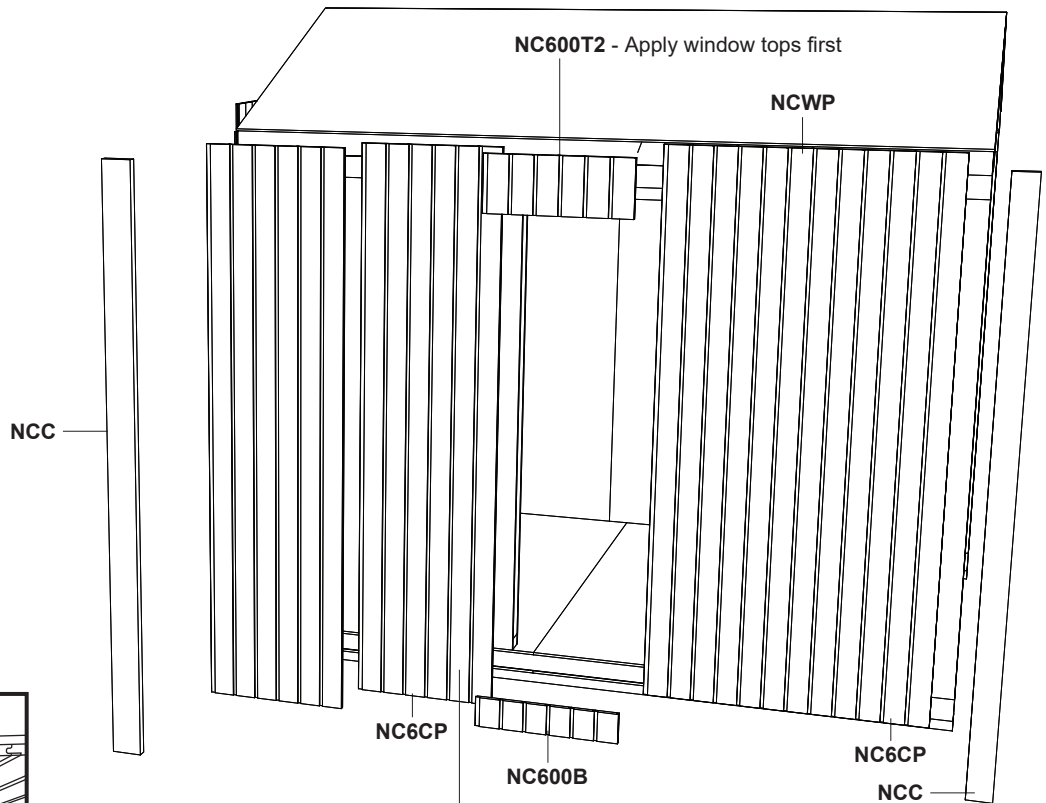
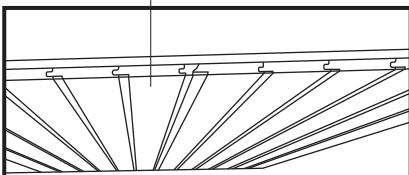

- Exterior cladding panel fix through predrilled holes.
- S60 mm screws.

49

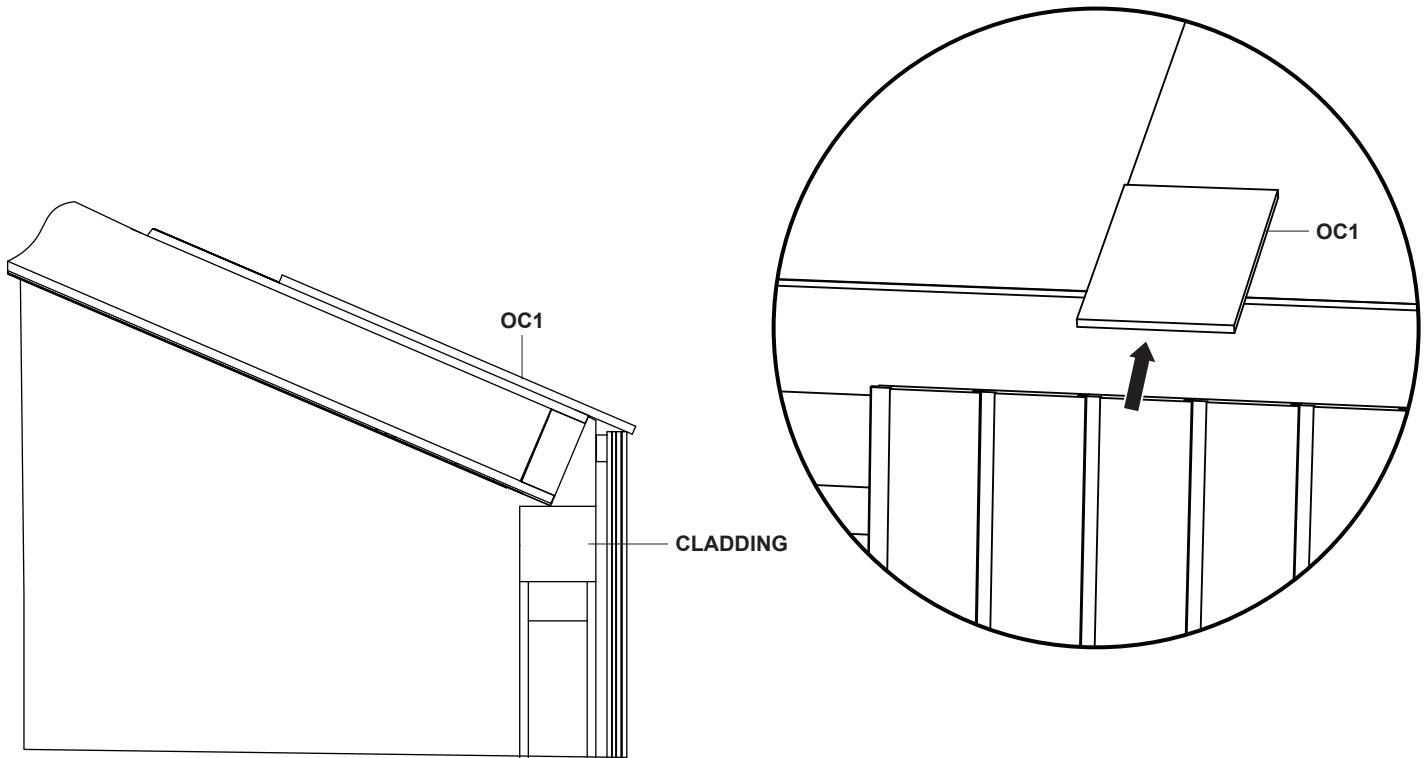

Use OSB offcut OC1 to set height of the first panel. Ensure to leave clearance for window.

50

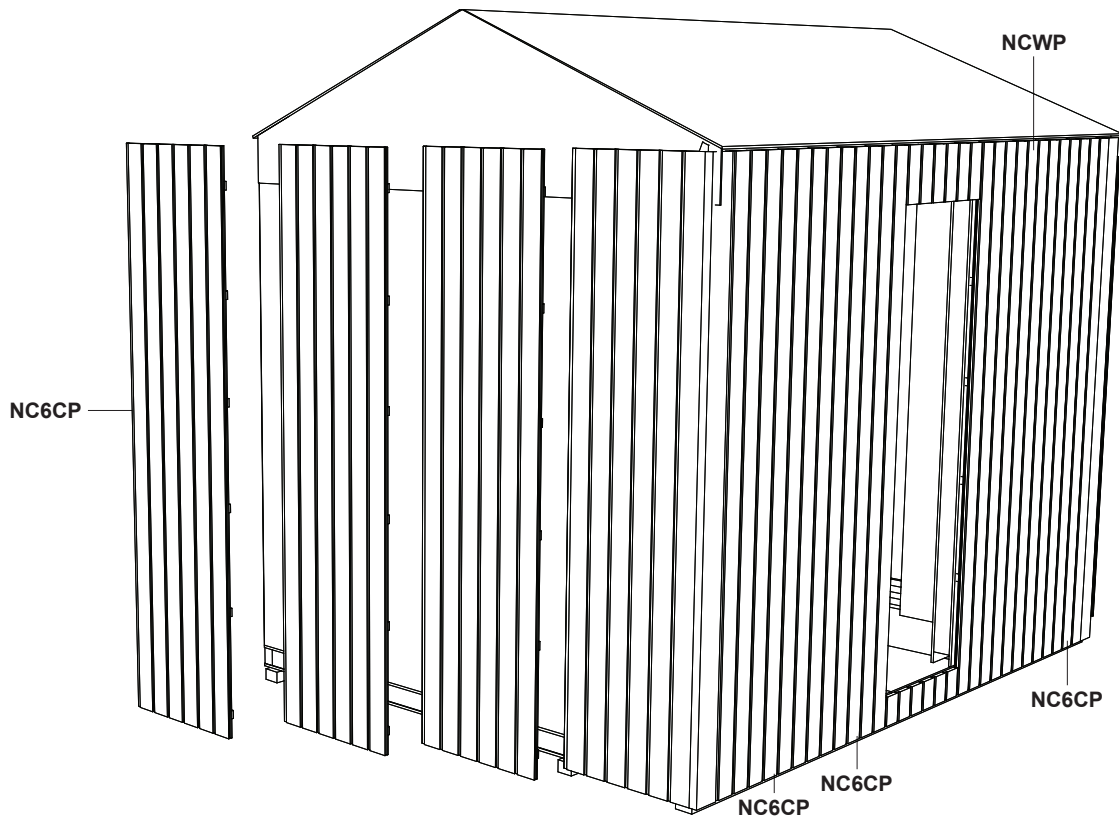

- NCWP should be placed on the right of each window to allow for window fitting.
- 5 cladding panels across the back.

51

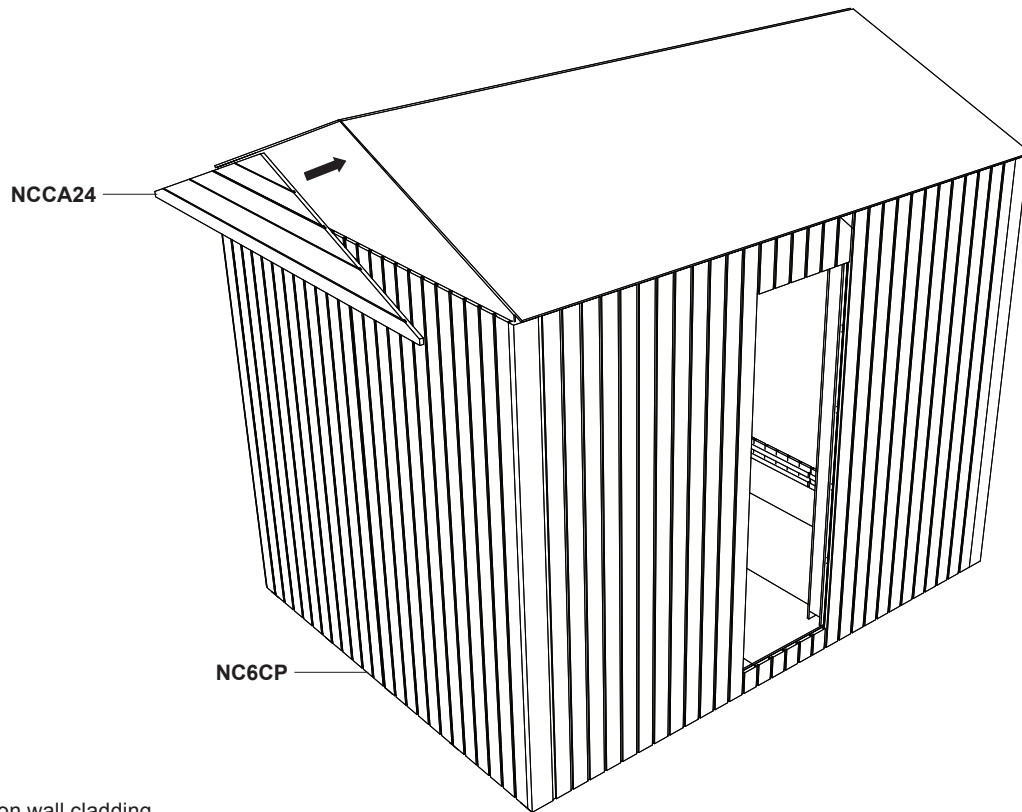

Set triangular panel on wall cladding.

52

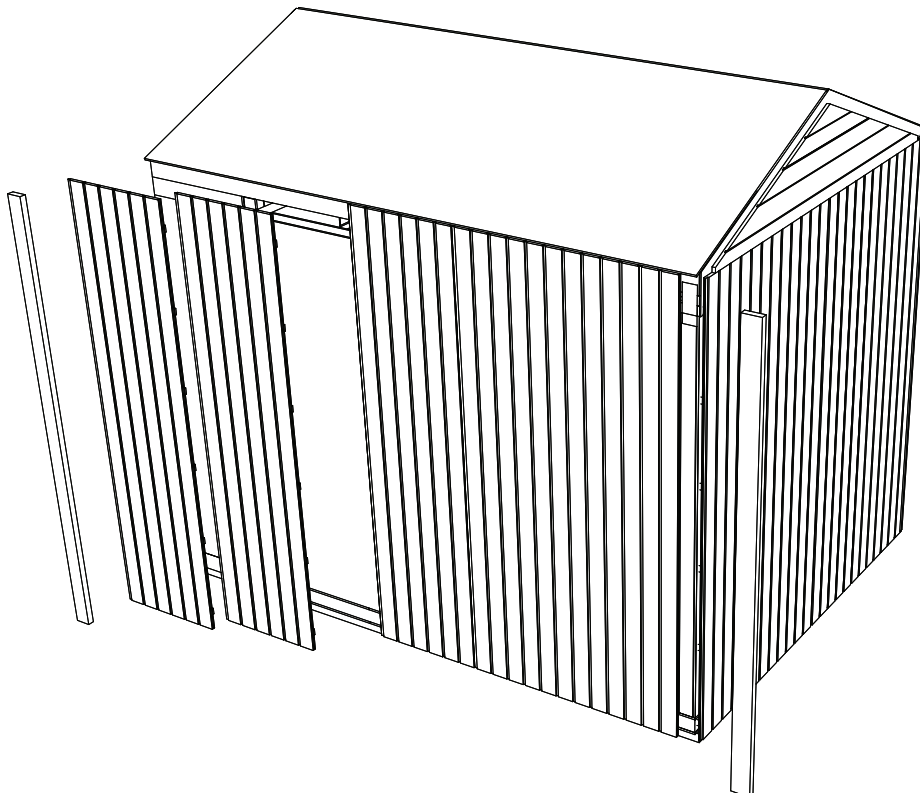

- Finish right side with corner planks.
- Ensure corners are not protruding beyond back panels.

53

Side panels NCCS24 are the same size but left and right with the cut against the wall.

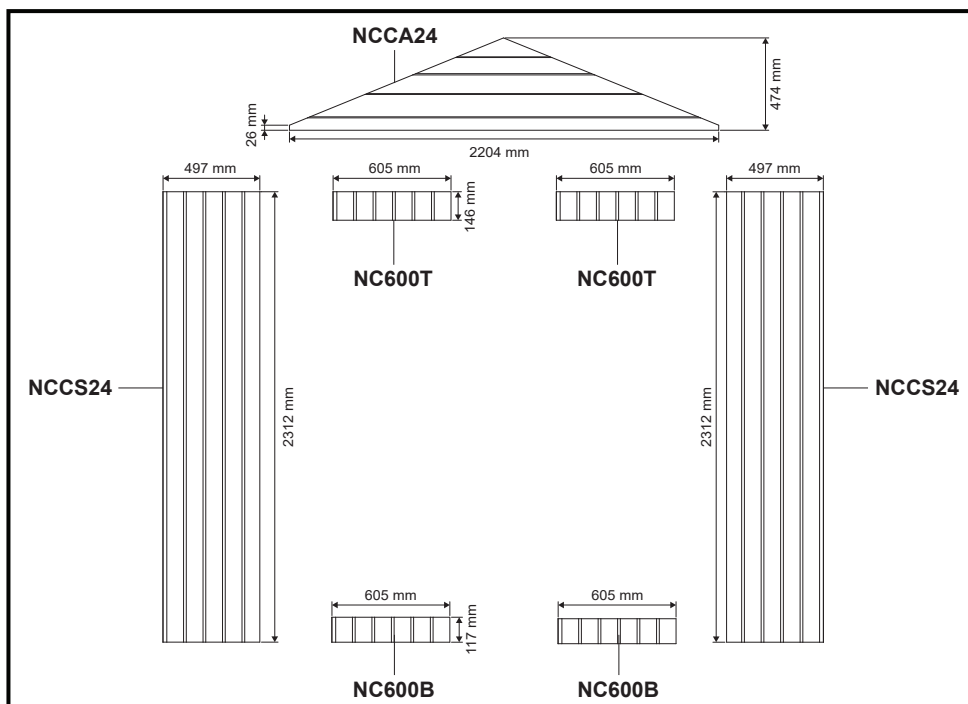
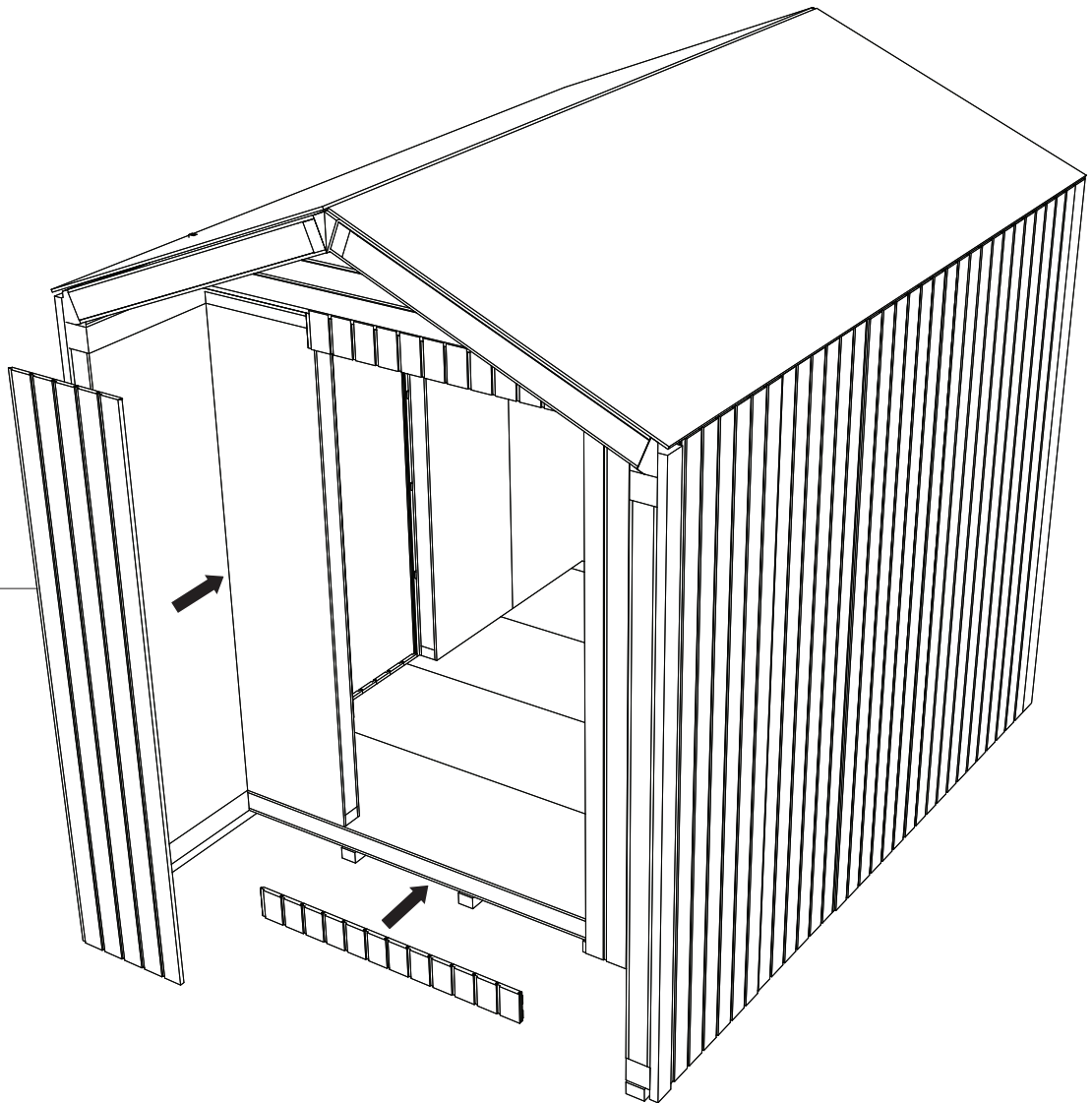

Install front panels first, start with the triangle NCCA24.

54

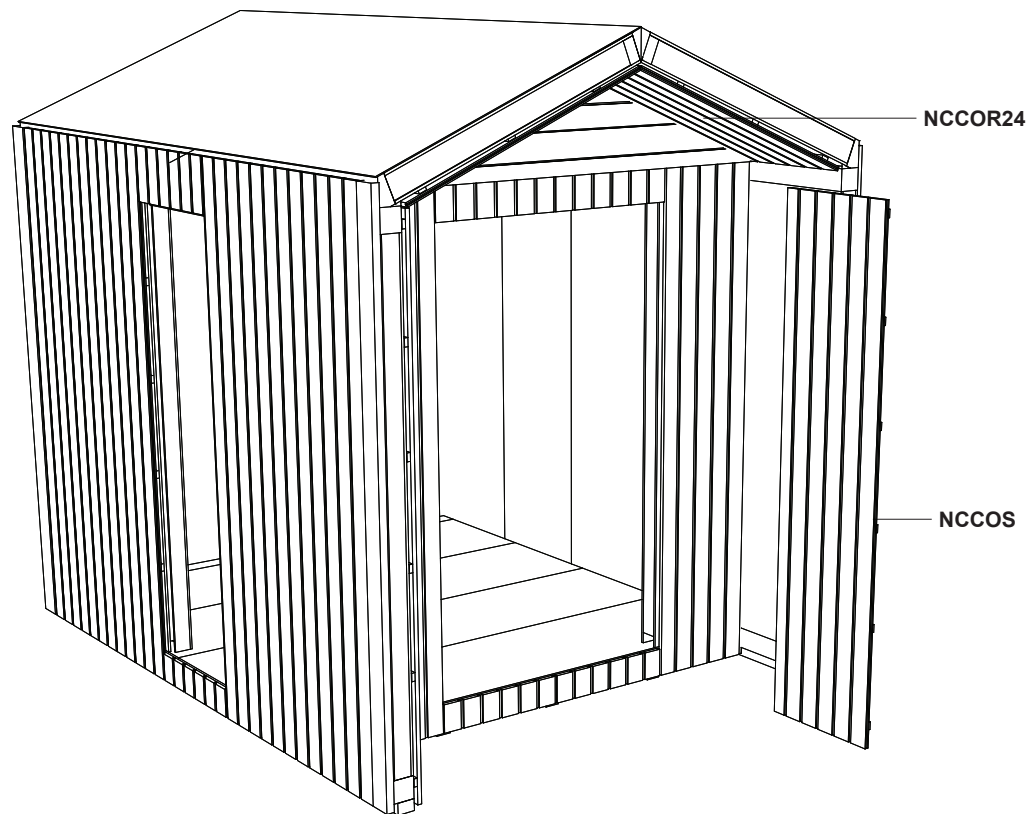

Cladding panels for the hood should be level with the end of the walls.

55

Roof shingles

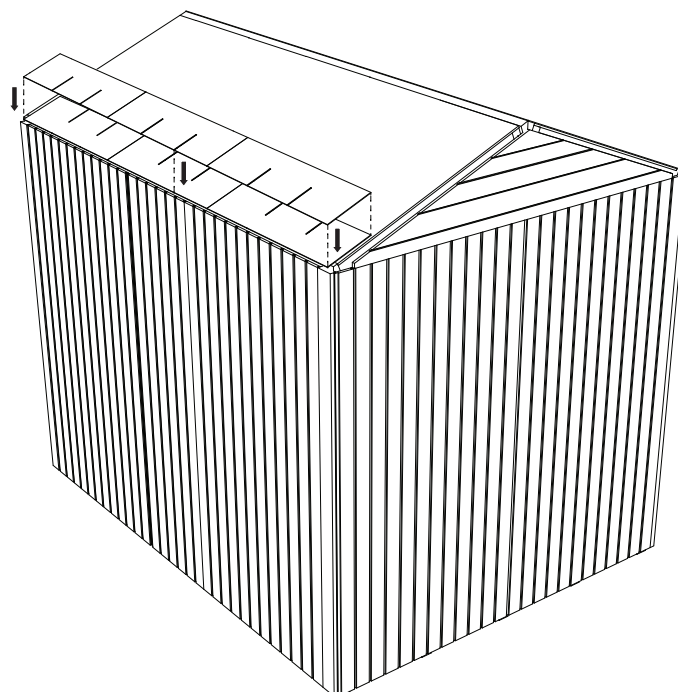
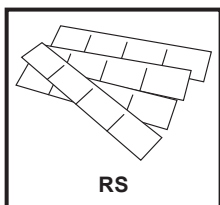

- Starting at the bottom right hand side of the roof, fix the first first row of shingles with galvanised clout nails CN, with the cut-outs facing up, leaving 50 mm overhang.
- Then fix the second layer of shingles on top of the first, with the cut-outs facing down as shown in the drawing. This is to stop any water ingress. Work your way from right to left attaching the first row of shingles.
- Second and each next row should be staggered and laid on top. At the ridge, shingles should be cut with a utility knife, using the apex line of the roof as the cut line.

56

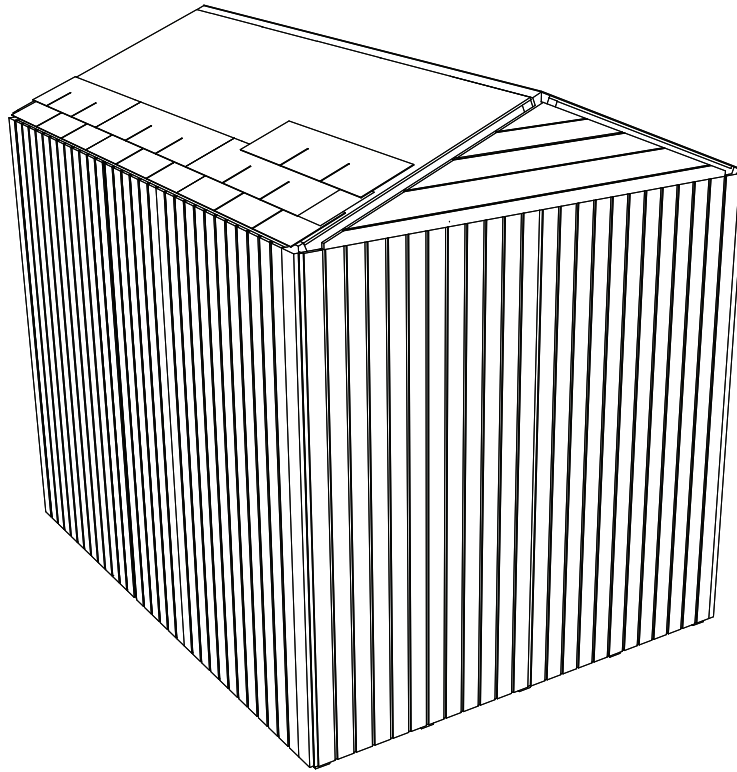

Continue to stagger shingles until the roof is complete.

57

Window installation

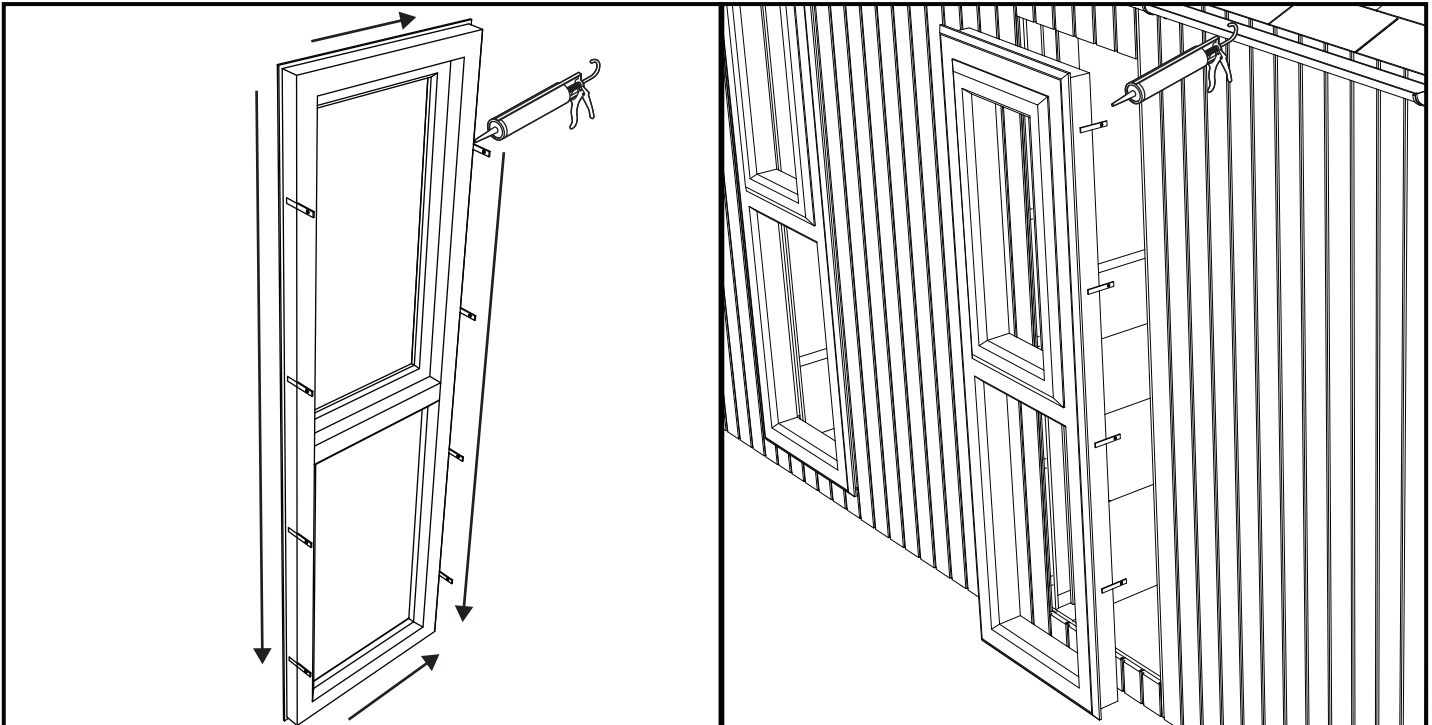

- Ensure window fits into the aperture.
- Apply a strong bead of sealant on window perimeter.

58

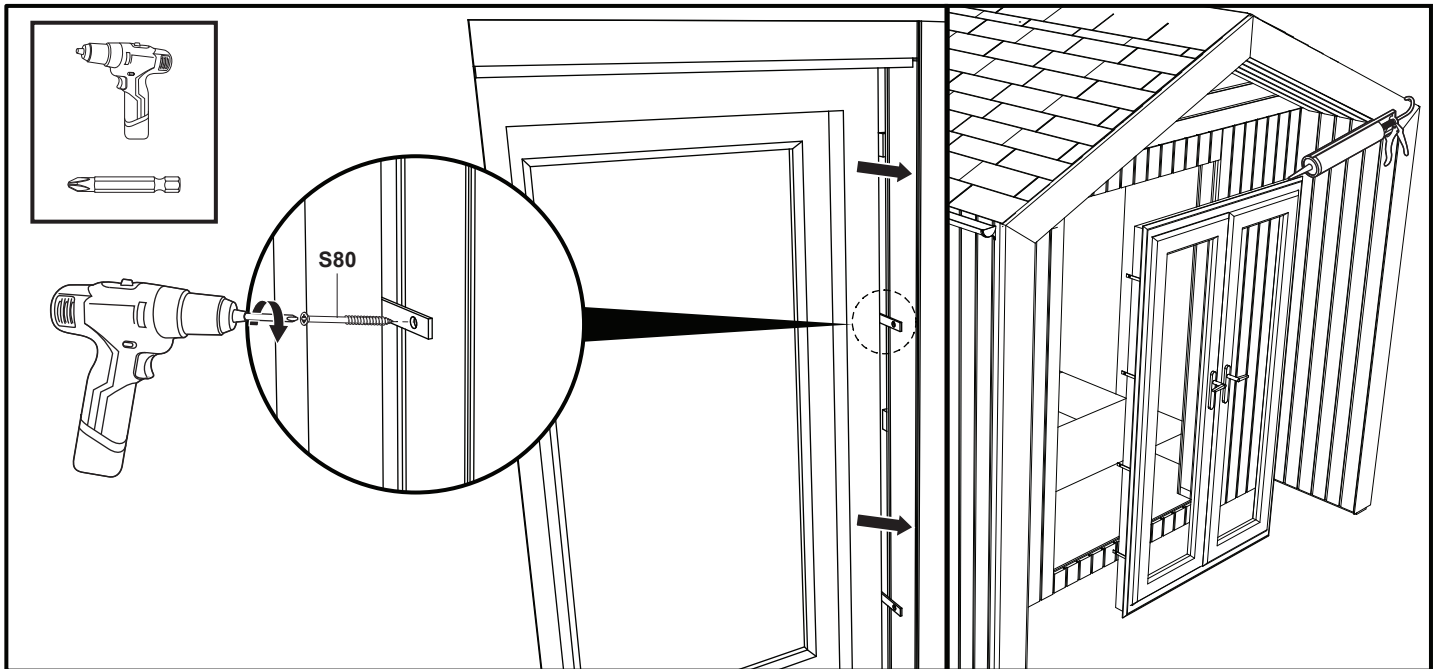

- Once frame have been inserted and fixed check if it is fitted plumb and straight.
- Press window from the exterior and secure the brackets with screws.
- Take care to ensure window is aligned in the aperture and the frame is pressed against the cladding.
- The door is connected using the same procedure.
- An extra person may be required to hold the door in place.

59

Roof and Wall trim

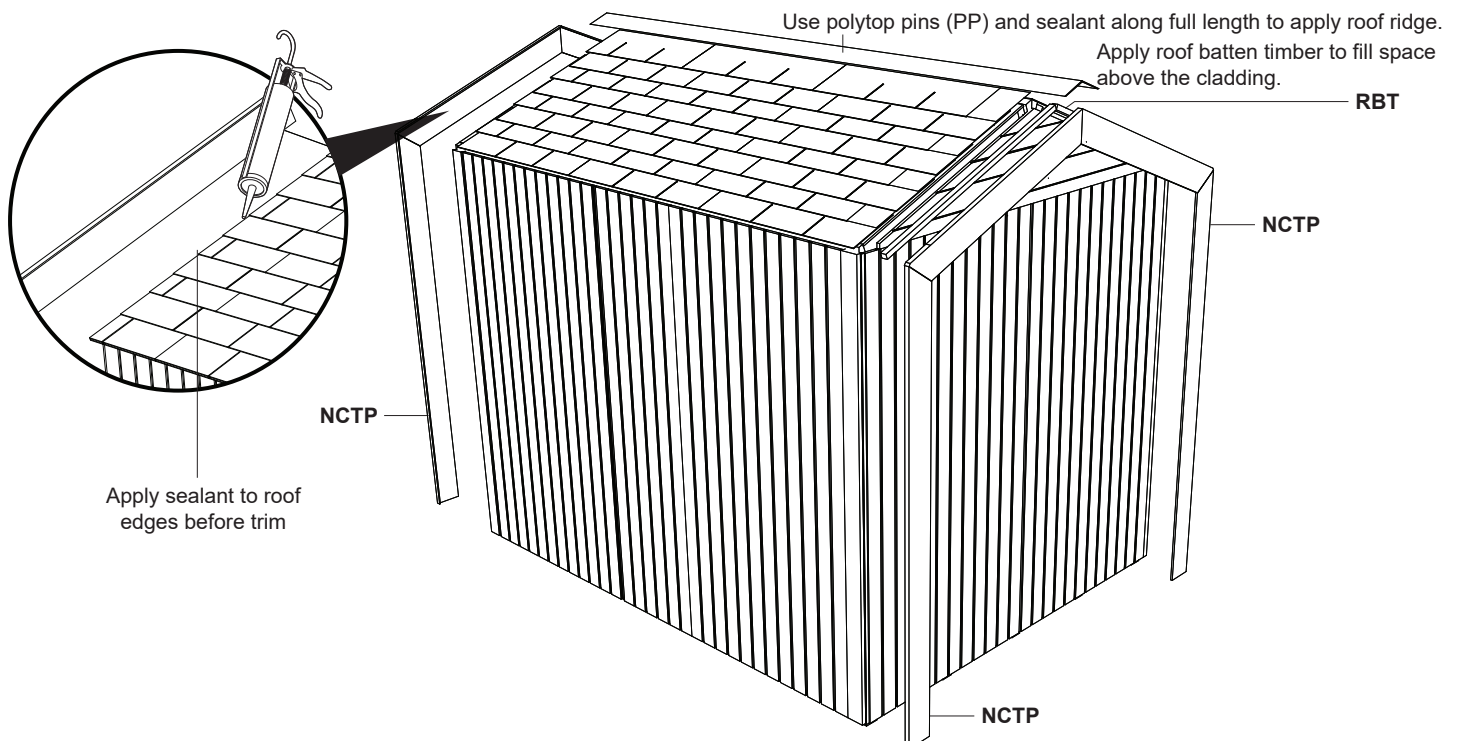

- Grey coverboard is applied with polytop pins in pairs every 400 mm using hammer, being careful not to over hit the pin.
- Coverboard pack front and back.

60

Guttering

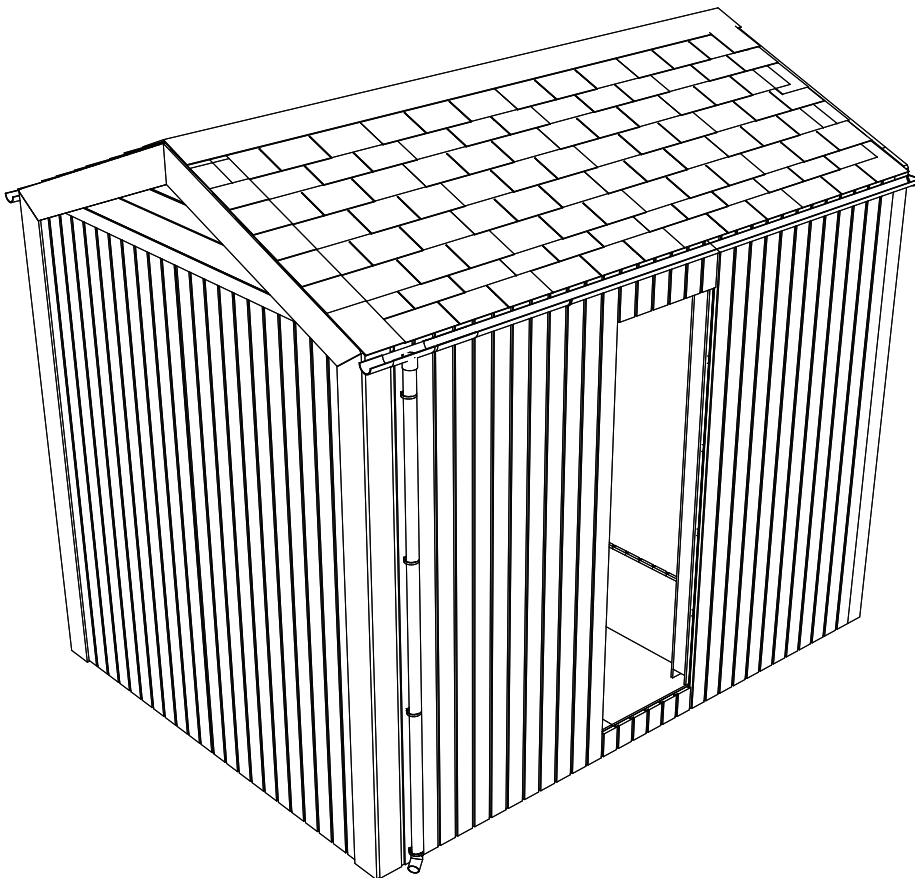
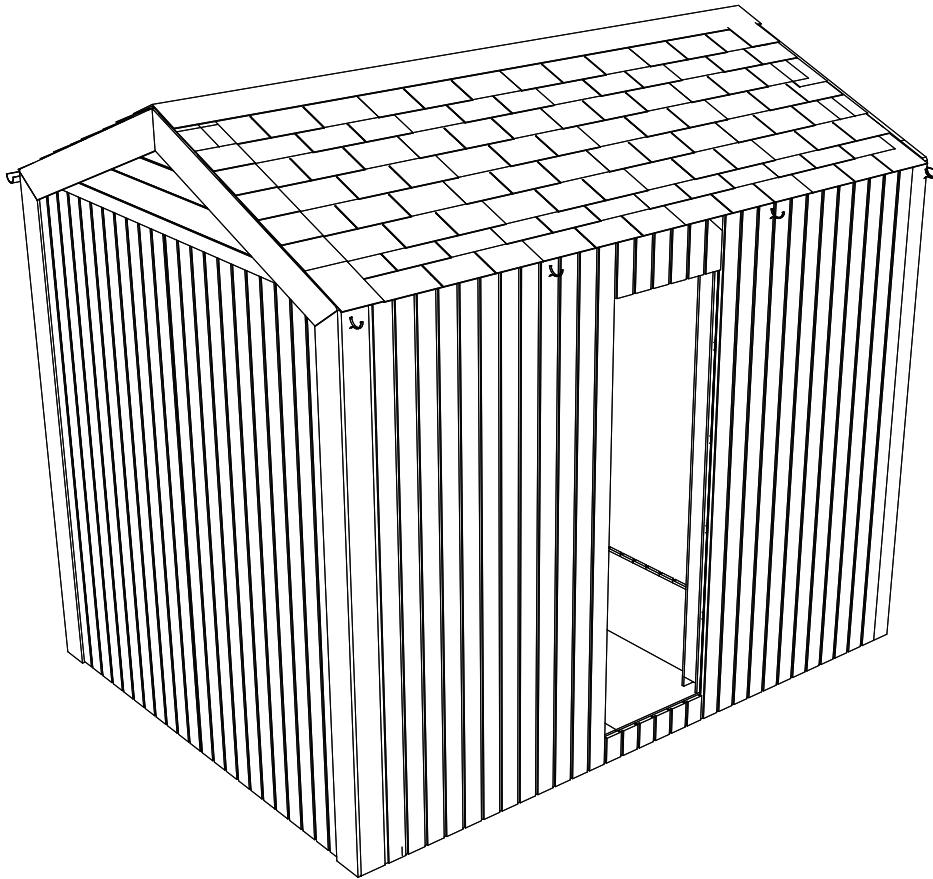

- Install brackets so water from roof will drip into gutter.
- Brackets should be 1cm higher at front of building to allow water to drain.

61

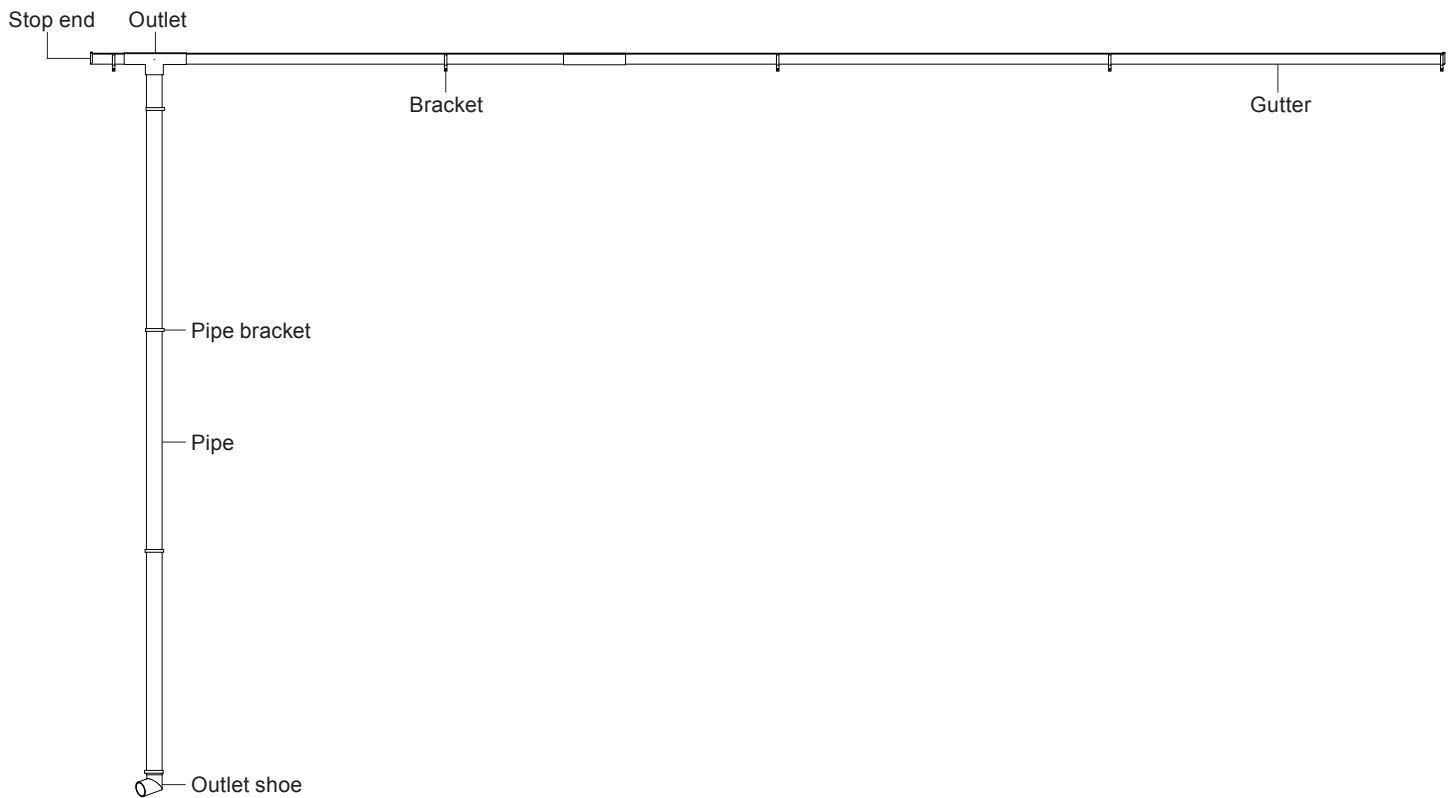

62

Internal cladding Walls

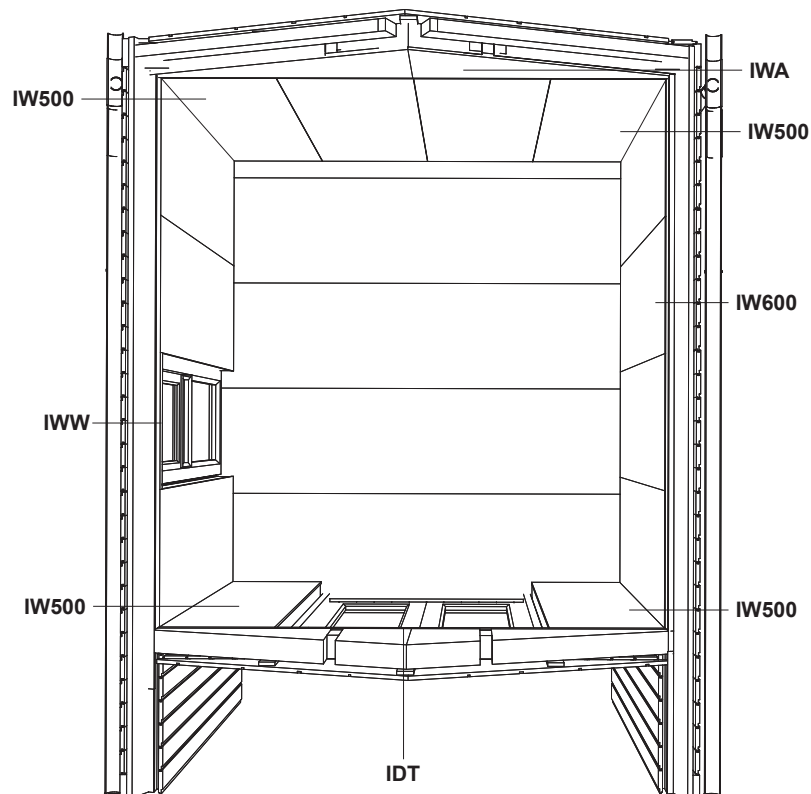

IWA will need trimming to fit around beams

- Cladding panels for the internal walls are fixed with 30 mm screws countersinking screws allow filler to be applied for painting.
- 6-8 screws per panel.
- Corner panels on the front and back are shorter than standard panel.

63

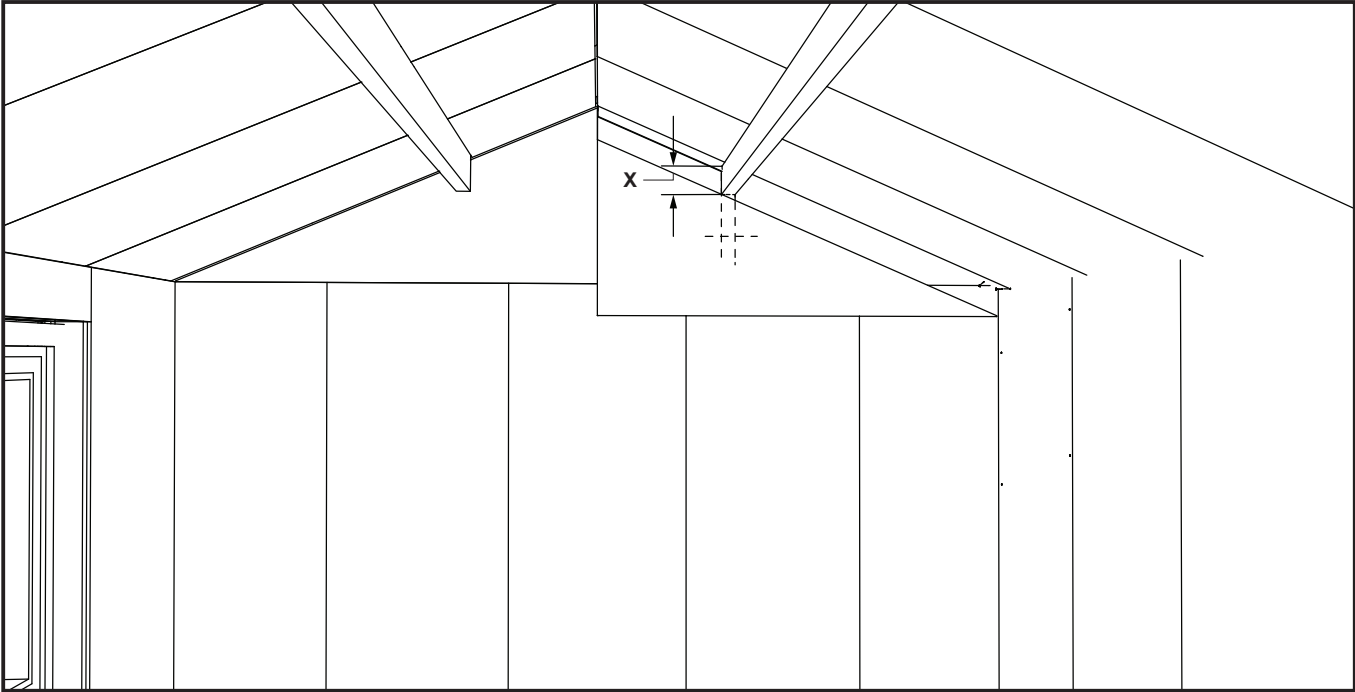

Mark up the internal top apex panel from the exposed roof beam.

64

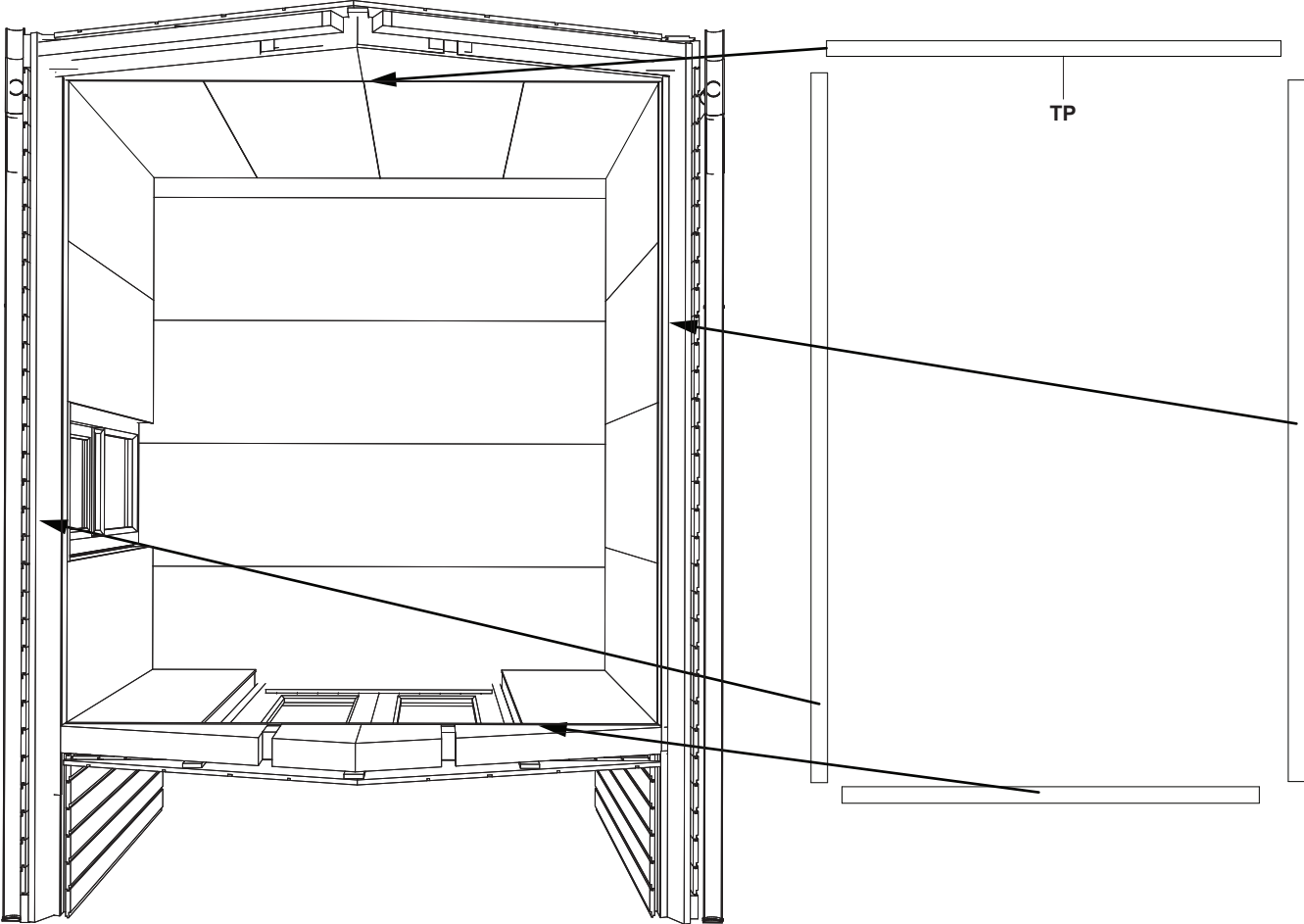

45

65

Internal cladding

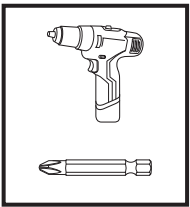

S30

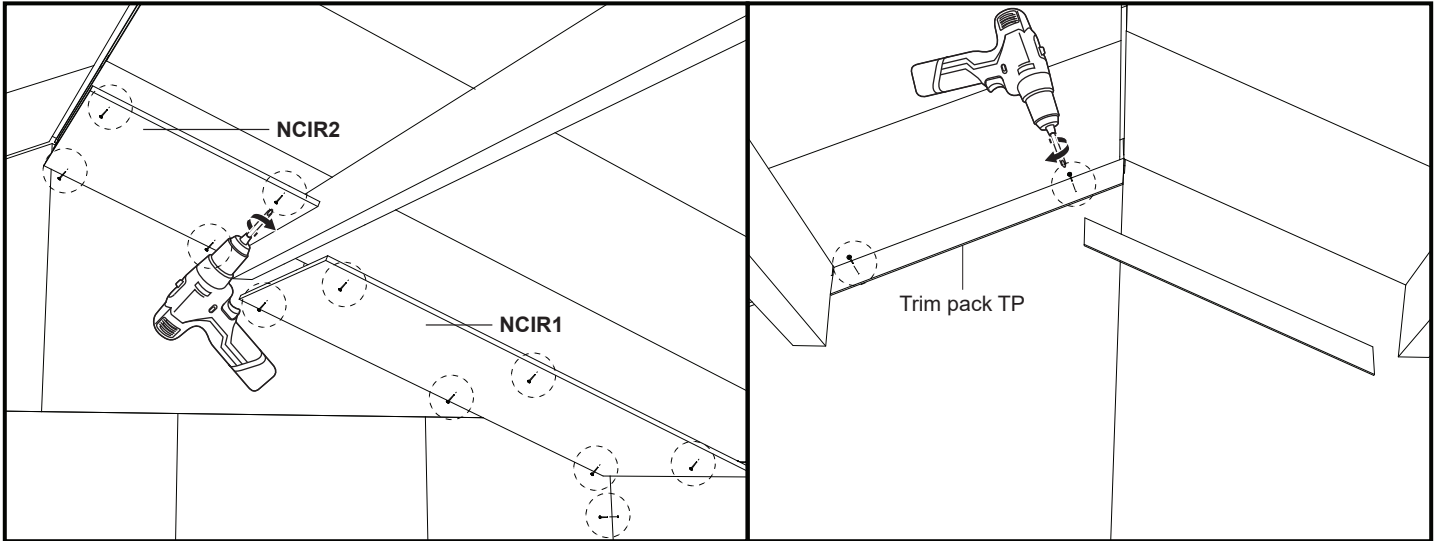

Use S30 screws to fix wall panels to side walls and roof panels NCIR1 and NCIR2 to the ceiling. Back wall panels have two thinner panels for the corners.

66

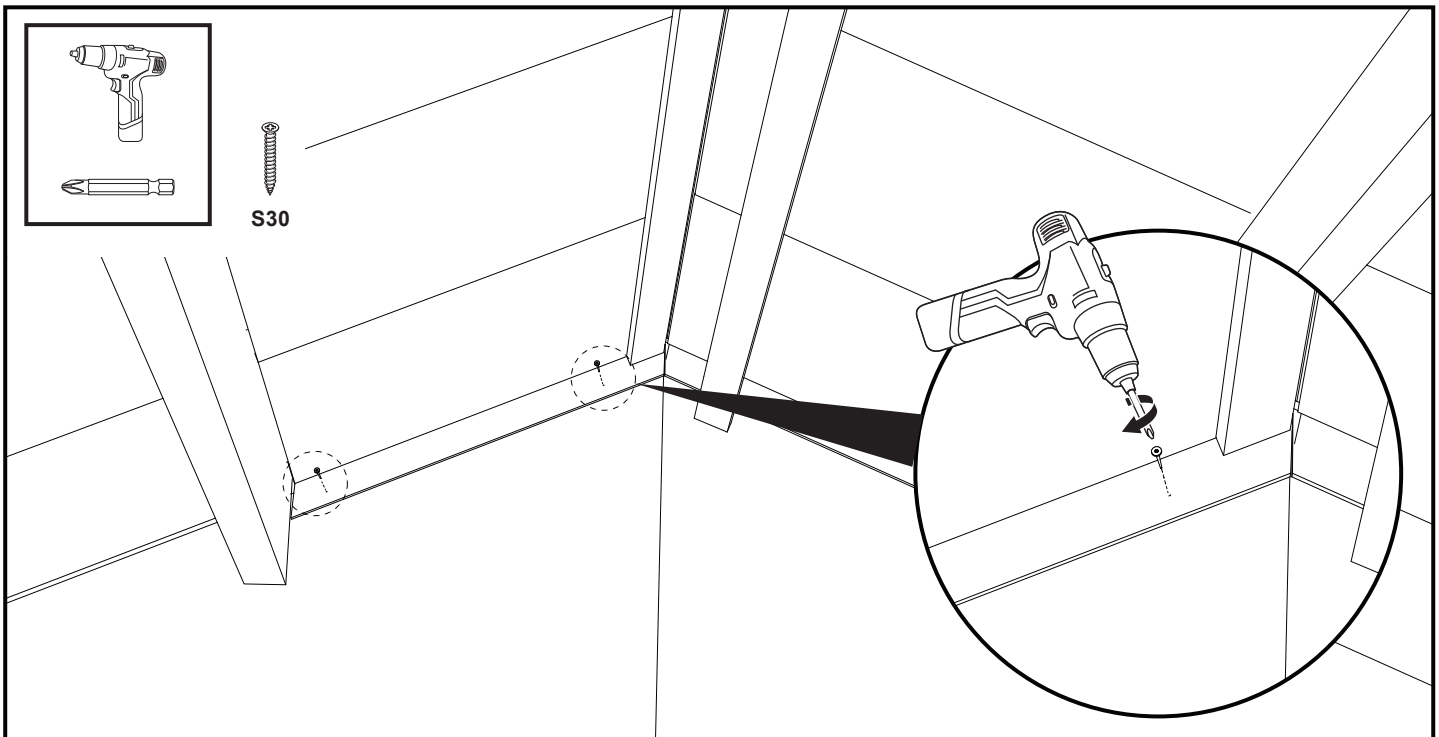

Gable wall trims will need to be cut (adjusted) from the supplied trim. Wall tops and centre trims can be pinned with veneer pins (VP) or screwed with S30 screws and filled.

67

Window and door trim

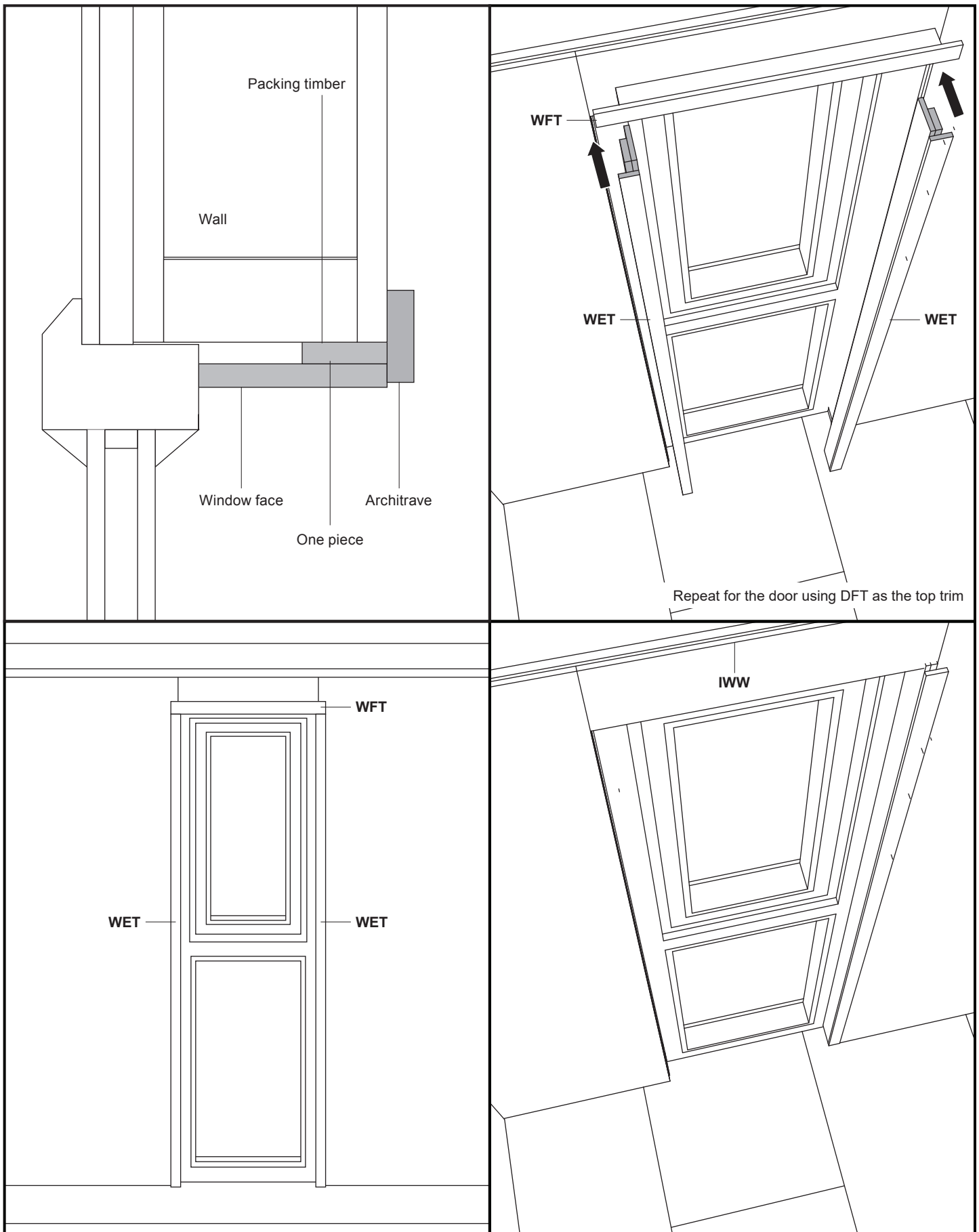

Fix front window trim with veneer pins (VP).

68

Door trim

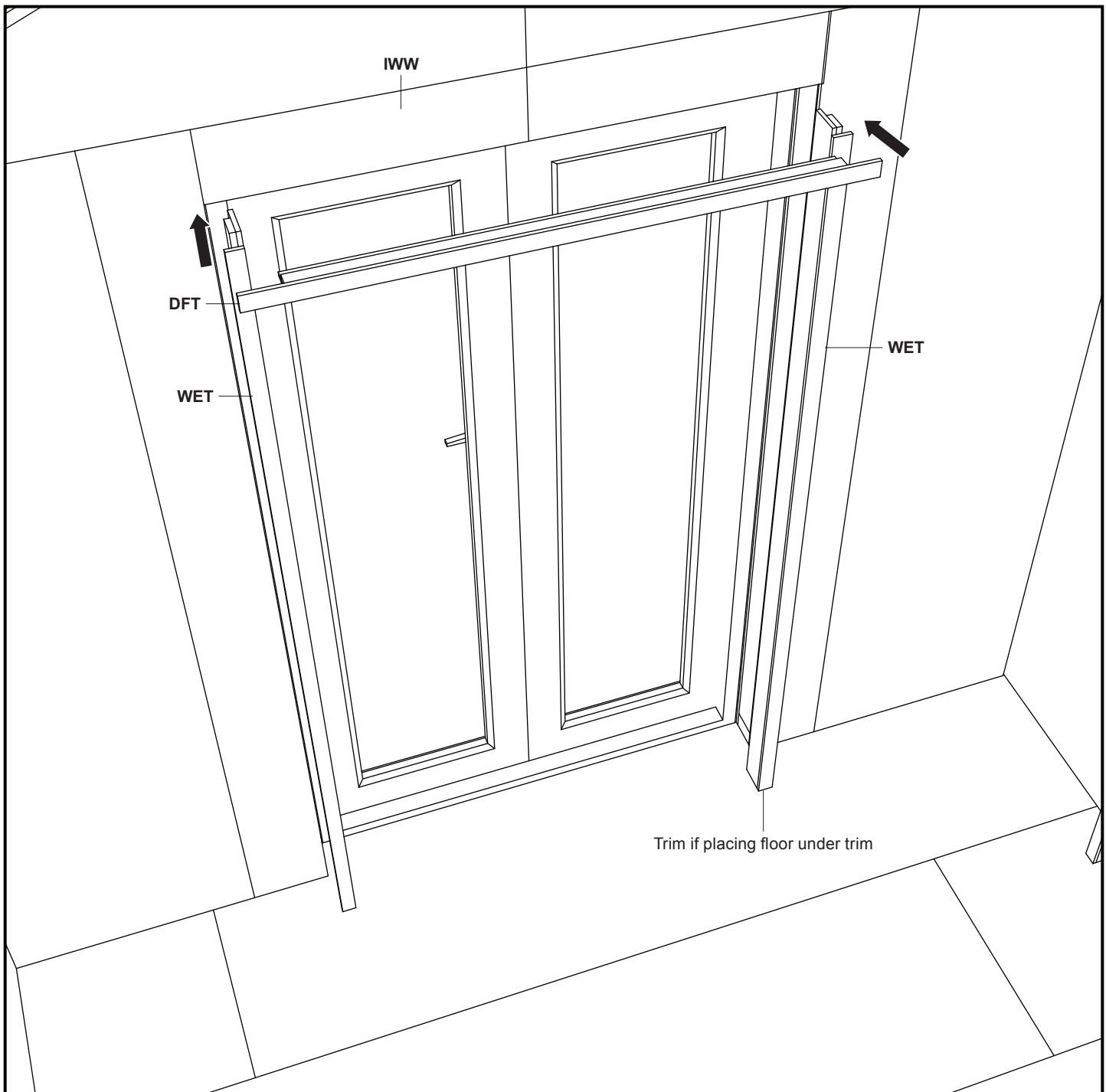

Fix front door trim with veneer pins (VP).

Supplied internal caulk IC can now be used for preparation for decorating.

EN Care & maintenance

- Maintaining your garden building is equally as important as the original build, and ensures the structure is set to last a long time. SEMORA garden rooms need little maintenance year on year; however, the key is to be proactive, with focus on the areas detailed in this instruction manual.
- Keep your garden room well ventilated to ensure there is as little build-up of moisture as possible. This is especially important when condensation becomes an issue during winter months, when there is a greater difference between inside and outside temperatures.
- Keep the area around the building clear - a constant airflow prevents moisture from being trapped underneath the building and damage occurring from the damp ground.
- No plants should be touching the garden room. Wall climbing plants, shrubs, and old leaves can quickly degrade and cause localised damp spots.
- Inspect and clear roof and guttering of all debris minimum twice a year.
- Regularly check that the roof materials are in good condition and all parts are correctly in place.
- Regularly check the condition of your product, and perform any repairs required.
- Check the condition of the silicone seals around doors and windows and replace them, if necessary.
- Doors and windows in the garden room will also need to be cleaned and maintained properly. Oil/lubricate hinges occasionally for maximum performance and longevity. To clean, use a soft cloth or sponge and a mild household detergent. Please do not use abrasive pads or solvent based cleaners as this may result in damaged surface or discolouring.
- Never use a jet washer or extension hose to power wash your garden room doors and windows.
- Even with treatment, moisture may enter through corners, knots, crevices and joints between parts. If necessary, apply silicone.
- Please note that porch canopy is not suitable for installation of swing/hanging chairs as it was not designed to support these additional live loads.

Snow

- If you live in the area that receives snow, it is always recommended to clear your roof of snow as soon as you can and after each snowfall. Layers more than 10 cm thick can be dangerous!
- Accumulation of snow on a flat roof can lead to water ponding, disfiguration of the roof membranes and more serious damage to the structure of the roof.
- Use of a plastic snow shovel to start removing as much excess snow as possible is recommended as metal shovels are more likely to damage the roof membranes.
- Once the excess snow is removed, a stiff broom or rake can be used to clear the surface of the roof, with care not to dig the broom or rake into the roof as this may cause damage.
- Clearing gutters and drains of all snow is important as well as snow will melt and is likely to build up, preventing a path to properly drain water from the roof, which may lead to water pooling and leaks.

Wood treatment

- Our external cladding is pressure treated, so does not require any maintenance. However, if you want to maintain the original look or change the colour, then you can do so with a water-based UV oil or wood stain. Follow the manufacturer's treatment instructions.

Door adjustment

- Door should open and close smoothly without rubbing or catching. Please ensure frames and hinges are clean and free from debris and dirt build-up. If necessary, hinges and cams can be adjusted to ensure a suitable fit.

Hinges

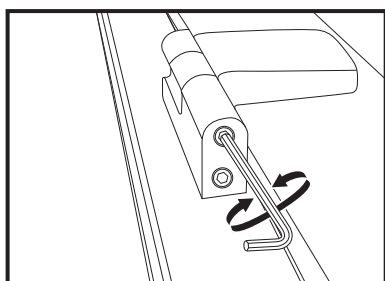

Compression Adjustment Screw allows installer or user to adjust required compression +/- 1.5 mm. Ensure compression is evenly distributed across all hinges.

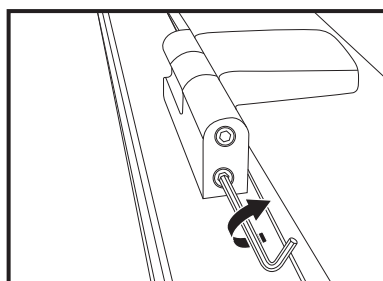

Height Adjustment Screw allows installer or user to adjust required height +8 mm / -0 mm. Ensure that weight of the door is evenly distributed across all hinges.

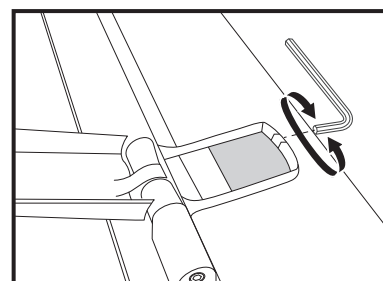

Lateral Adjustment Screw allows installer or user to adjust required lateral setting +/- 6 mm. Ensure this adjustment is evenly distributed across all hinges.

Cams

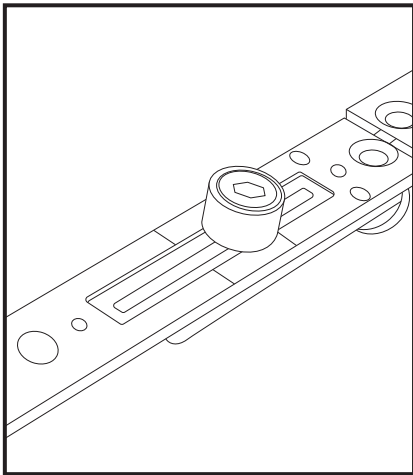

R - Cams allows installer or user to optimize the window or door compression by +/- 1.2 mm.

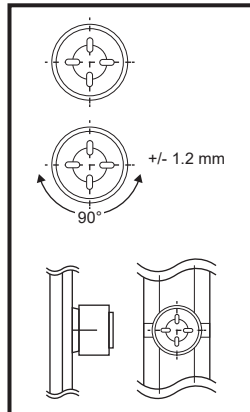

Adjustment tool

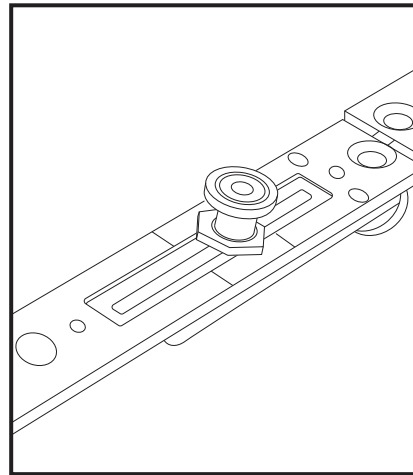
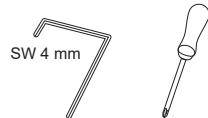

RS - Cams allows installer or user to optimize the window or door compression by +/- 0.8 mm.

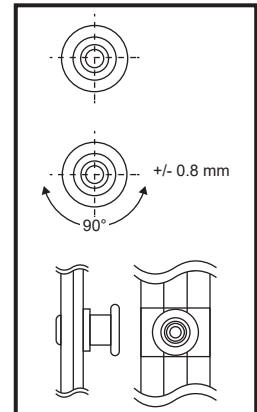

Adjustment tool

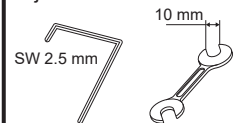

Always push the handle up to engage locks when the door is closed to ensure best performance and door stability.

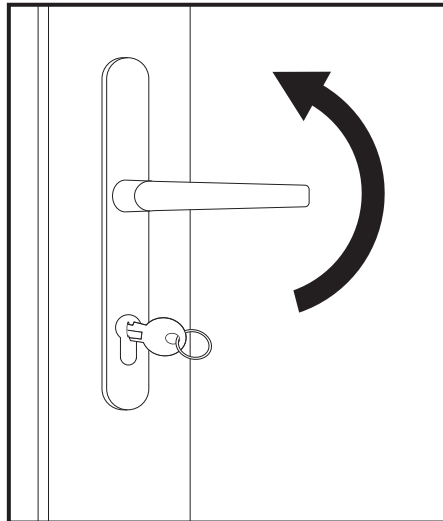

Manufacturer:

UK Manufacturer:

Kingfisher International Products Limited,
1 Paddington Square, London, W2 1GG,
United Kingdom

EU Manufacturer:

Kingfisher International Products B.V.,
Rapenburgerstraat 175E,
1011 VM Amsterdam,
The Netherlands

EN www.diy.com

www.screwfix.com

www.screwfix.ie

**To view instruction manuals online,
visit www.kingfisher.com/products**