

**ASSEMBLY INSTRUCTIONS
INSTRUCTIONS DE MONTAGE
INSTRUCCIONES DE MONTAJE**

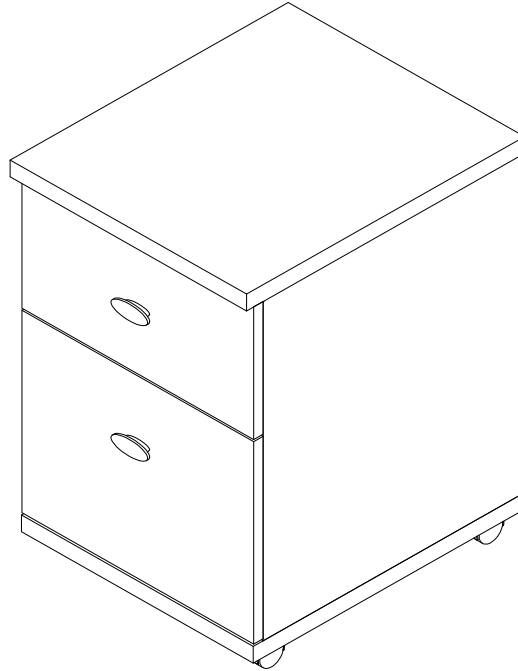

Item No./Numéro d'article/Artículo No: G115001800



WE HAVE YOU IN MIND, LET US SERVE YOU!

Questions? Issues?

CONTACT US

24 hours / 7 days a week



ONE YEAR WARRANTY



customer.care@sunjoygroup.com



G11500180021

Country of Origin: China
Pais d'origine: Chine
Pais de origen: China

Production Number: xxxxxxxxxx
Numéro de fabrication: xxxxxxxxxx
Número de producción: xxxxxxxxxx

Important Safety Instructions / Instructions Importantes de Sécurité / Instrucciones Importantes de Seguridad



Warning! Please read and understand this entire manual before attempting to assemble or operate this product.

Avertissement! Veuillez lire et comprendre ce manuel complet avant d'essayer de monter ou faire fonctionner ce produit.

¡Aviso! Por favor, lea y asegúrese entender este manual completamente antes de tratar de montar u operar este producto.

- Choking hazard – This product contains small parts. Keep all hardware out of reach of children.
- Two people are recommended for assembly.
- Unpack on a soft, smooth surface and inventory all parts.
- DO NOT overtighten any connectors.
- Philips head screwdriver (not provided) required for assembly.
- Danger d'étouffement – Ce produit contient des petites pièces. Garder toute la quincaillerie hors de la portée des enfants.
- Deux personnes sont recommandées pour le montage.
- Déballez sur une surface douce, lisse et faites l'inventaire de toutes les pièces.
- NE serrez aucune des connexions trop fortement.
- Un tournevis Phillips (pas inclus) est nécessaire pour le montage.
- Peligro de Asfixia – Este producto contiene piezas pequeñas. Mantenga toda la ferretería fuera del alcance de los niños.
- Desembale sobre una superficie suave y lisa y verifique que todas las piezas estén incluidas.
- NO apriete demasiado ninguna conexión.
- Se necesitara un destornillador (no incluido) tipo Philips (en Cruz) para el montaje.

Caution! Weight Limitations / Précaution! Limites de Poids / ¡Precaución! Limitaciones de Peso

This accent console is intended for use only with products and maximum weights shown on this label. Use with other products or products heavier than maximum weights shown below may result in instability causing possible injury.

Cette console d'accent est conçue pour utiliser uniquement avec les produits et les poids maximums indiqués dans cette étiquette. Son emploi avec d'autres produits ou des produits plus lourds que les poids maximum indiqués ci-dessous peuvent occasionner instabilité provoquant possiblement des blessures.

Este compartimento de acento tiene es con intención a ser utilizado únicamente con productos y pesos máximos indicados en esta etiqueta. Su empleo con otros productos o productos más pesados que los pesos máximos indicados debajo puede provocar inestabilidad, causando posibles lesiones.

Maximum top weight: 131.5 kg/290 lb
Poids total maximum: 131.5 kg/290 lb
Peso Máximo de la Mesa: 131.5 kg/290 lb

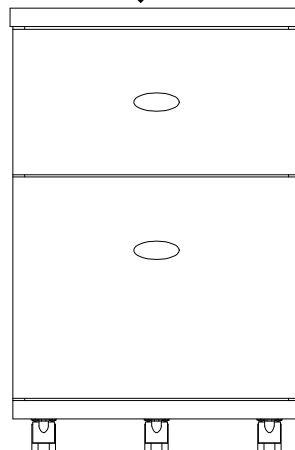



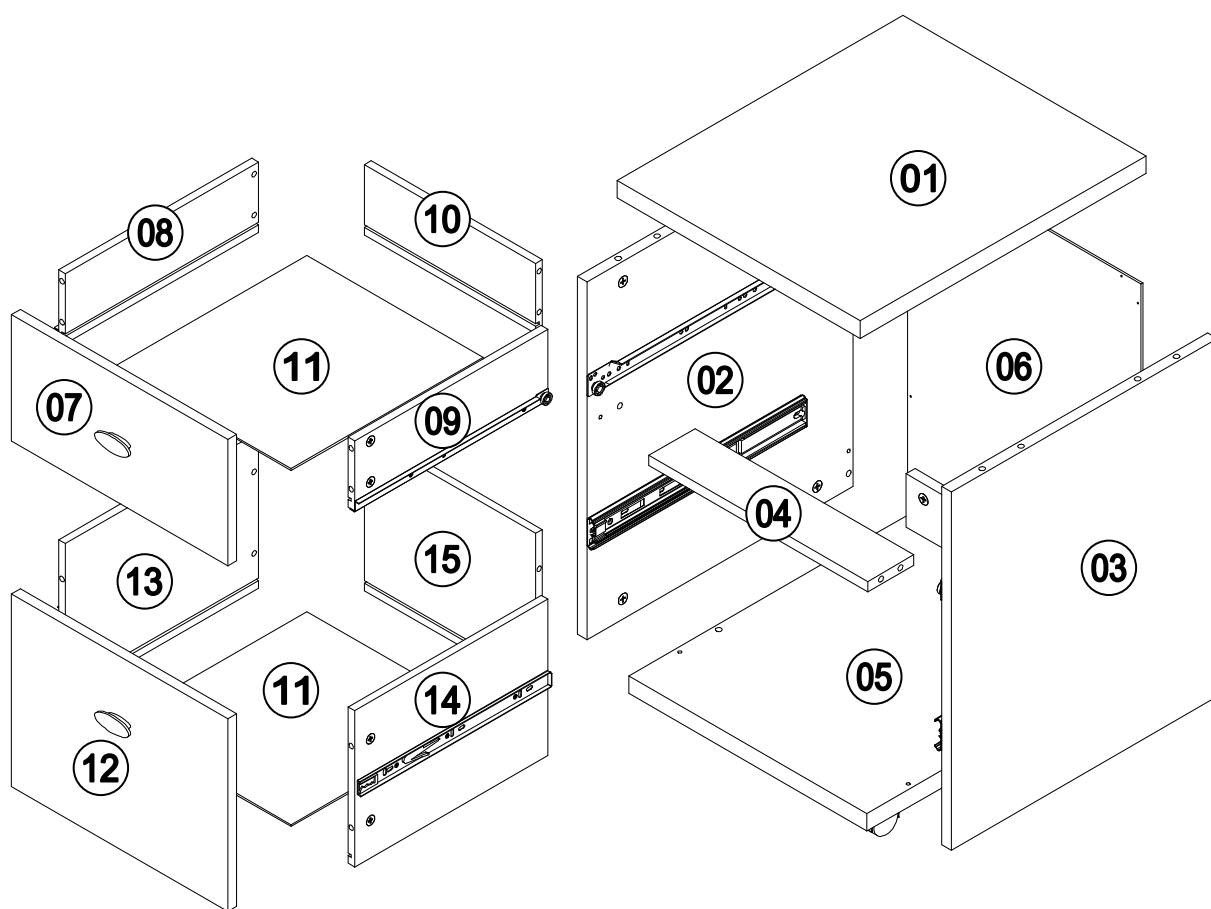

Exploded Drawing / Diagramme Agrandi / Diagrama Agrandad



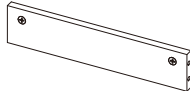
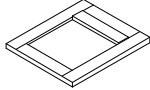

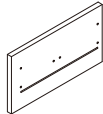
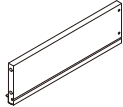
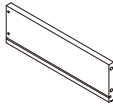
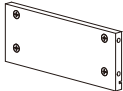
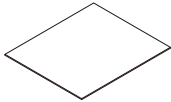
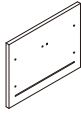

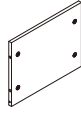



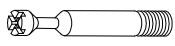

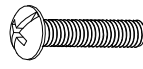
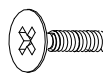
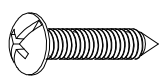
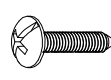
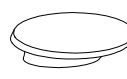
Parts List / Liste de Pièces / Lista de Piezas

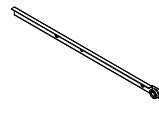
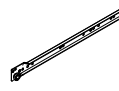
Label Étiquette Etiqueta	Part Number Diagramme de la Pièce Diagrama de la pieza	Description Description Descripción	Qty Quantité Cantidad	Part Image Diagramme de la Pièce Diagrama de la pieza
01	P00210045901	Table Top Dessus de Table Encimero	1	
02	P00380056201	Left Side Panel Panneau du Côté Gauche Panel Lateral Izquierdo	1	
03	P00380056301	Right Side Panel Panneau du Côté Droit Panel Lateral Derecho	1	

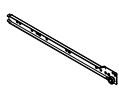
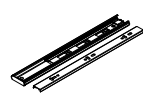
04	P00050159201	Connect Panel Panneau de Connexion Panel de Conexión	2	
05	P00010041801	Base Base Base	1	
06	P00400032601	Back Panel	1	
07	P00390013201	Box Drawer Front Panel 1 Panneau Avant de la Boite du tiroir 1 Panel Frontal del Armazón del Cajón 1	1	
08	P00380056401	Box Drawer Left Side 1 Côté Gauche de la Boite du tiroir 1 Lateral Izquierdo del Armazón del Cajón 1	1	
09	P00380056501	Box Drawer Right Side 1 Côté Droit de la Boite du tiroir 1 Lateral Derecho del Armazón del Cajón 1	1	
10	P00400032701	Box Drawer Back Panel 1 Panneau Arrière de la Boite du tiroir 1 Panel Trasero del Armazón del Cajón 1	1	
11	P00430010101	Box Drawer Bottom Panel Panneau du Fond de la Boite du tiroir Panel Inferior del Armazón del Cajón	2	
12	P00390013301	Box Drawer Front Panel 2 Panneau Avant de la Boite du tiroir 2 Panel Frontal del Armazón del Cajón 2	1	
13	P00380056601	Box Drawer Left Side 2 Côté Gauche de la Boite du tiroir 2 Lateral Izquierdo del Armazón del Cajón 2	1	
14	P00380056701	Box Drawer Right Side 2 Côté Droit de la Boite du tiroir 2 Lateral Derecho del Armazón del Cajón 2	1	
15	P00400032801	Box Drawer Back Panel 2 Panneau Arrière de la Boite du tiroir 2 Panel Trasero del Armazón del Cajón 2	1	

Hardware Pack / Sachet de Quincaillerie / Bolsa de Ferretería

Label Étiquette Etiqueta	Part Number Diagramme de la Pièce Diagrama de la pieza	Description Description Descripción	Qty Quantité Cantidad	Part Image Diagramme de la Pièce Diagrama de la pieza
H1	H100010064	Cam Bolt D6*35 Boulon de la Came D6*35 Tornillo de Leva D6*35	28	
H2	H100020003	Cam Lock Ø15*12 (preassembled) (pré-installée) (ya montado)	28	
H3	H010110072	Bolt M4*20 Boulon M4*20 Tornillo M4*20	4	
H4	H030050049	Screw ST3.2*12 (preassembled) Vis ST3.2*12 (pré-installée) Tornillo ST3.2*12 (pré-installée)	24	
H5	H030070492	Screw ST3.5*20 Vis ST3.5*20 Tornillo ST3.5*20	20	
H6	H030040043	Screw ST3.5*12 Vis ST3.5*12 Tornillo ST3.5*12	14	
HH1	P00510034101	Handle Manche Mango	2	
HH2	H060030003	Dowel Ø8*30 Cheville Ø8*30 Clavija Ø8*30	12	
HH3	P005100171	Drawer Slide 1 (preassembled) Coulisse du Tiroir 1 (pré-installée) Corredero del Cajón 1 (ya montado)	1	
HH4	P005100172	Drawer Slide 2 (preassembled) Coulisse du Tiroir 2 (pré-installée) Corredero del Cajón 2 (ya montado)	1	
HH5	P005100173	Drawer Slide 3 (preassembled) Coulisse du Tiroir 3 (pré-installée) Corredero del Cajón 3 (ya montado)	1	
HH6	P005100174	Drawer Slide 4 (preassembled) Coulisse du Tiroir 4 (pré-installée) Corredero del Cajón 4 (ya montado)	1	
HH7	P005100134	Drawer Slide 5 (preassembled) Coulisse du Tiroir 5 (pré-installée) Corredero del Cajón 5 (ya montado)	2	

HH8	P00330005900	Caster Roulette Rueda	5	
HH9	P005100324	File Bar 1 Barre du Fichier 1 Barra de Archivo 1	1	
HH10	P00760010400	File Bar 2 Barre du Fichier 2 Barra de Archivo 2	2	

Cam Bolt + Cam Lock Hidden Connector System Assembly Technique
 Boulon de la Came + Verrou de Came Technique de Montage du Système de Connexion
 Tornillo de Leva + Técnica de Montaje del Sistema de Conexión del tornillo de leva

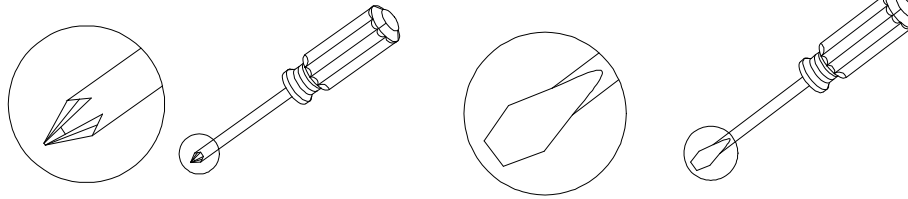

Screw the cam bolt into the threaded inserts on the panel.

Connect both panels together, making sure the cam bolt goes into the pre-drilled hole on the end of panel and is visible so the cam lock can be attached.

Insert the cam lock into the pre-drilled large hole on the panel, making sure the arrow on the face of the cam lock faces out and points toward to cam bolt.

Take a Phillips head screwdriver and rotate cam lock clockwise to lock the cam bolt into place.

Vissez le boulon de la came dans les orifices filetés du panneau.

Connectez les deux panneaux ensemble, tout en vous Assurant que le boulon de la came entre dans l'orifice déjà percé à l'extrémité du panneau et qui est visible pour que de verrou de la came puisse se fixer.

Introduisez le verrou de la came dans le grand orifice déjà percé sur le panneau, tout en vous Assurant que la flèche sur la face du verrou de la came se dirige vers l'extérieur et ver le boulon de came.

Avec un tournevis Phillips (en croix), tournez le verrou de came vers la droite pour verrouiller la came en place.

Atornille el tornillo de leva en el inserto con rosca sobre el panel.

Conecte los paneles juntos, asegurándose que el tornillo de leva entra en el orificio ya taladrado del la extremidad del panel y que sea visible para poder conectar el tornillo de leva.

Introduzca el tornillo de leva en el orificio grande, ya taladrado del panel, asegurándose que la fleche de la cara del tornillo de leva apunta hacia fuera y hacia el tornillo de leva.

Con un destornillador Phillips (en cruz) gire el tornillo de leva hacia la derecha para bloquear el tornillo de leva en su sitio.

HIDDEN CONNECTOR.ASSEMBLY TECHNIQUES / CONNEXION CACHÉE.TECHNIQUE DE MONTAGE / CONEXIÓN OCULTA.TÉCNICAS DE MONTAGE

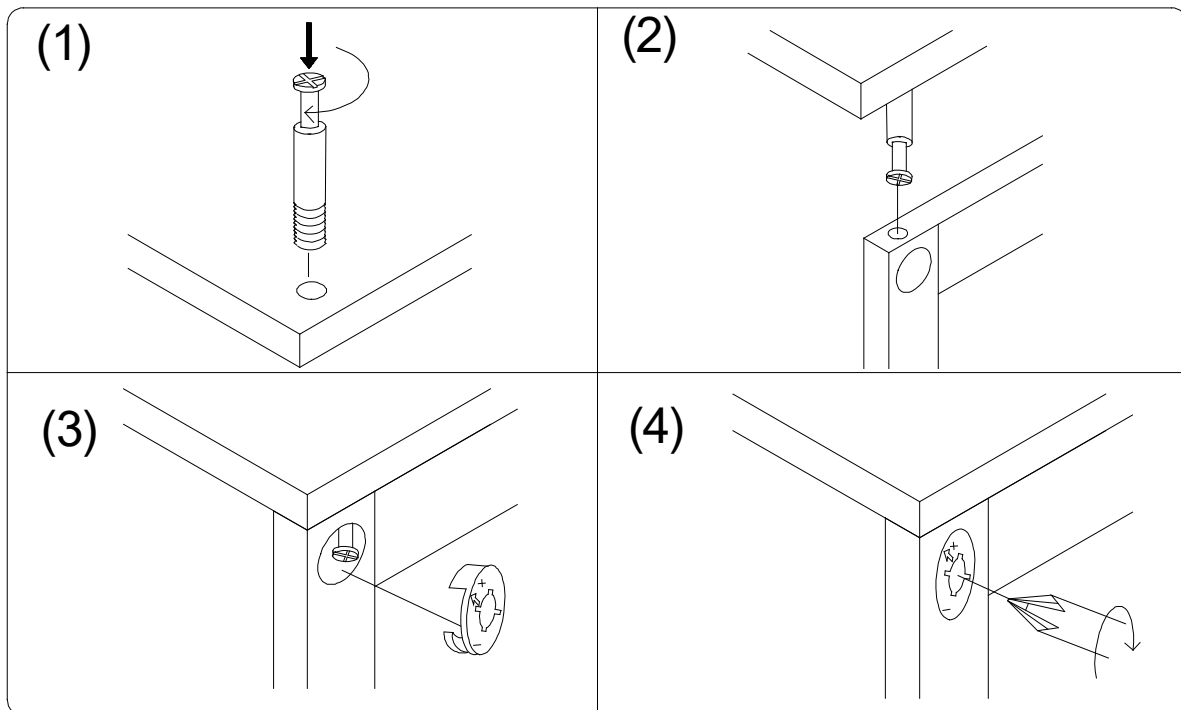

Before beginning assembly of product, make sure all parts are present. Assemble on a soft surface.

Avant de commencer à assembler le produit, assurez-vous que toutes les pièces sont présentes. Assemblez sur une surface douce.

Antes de empezar a montar el producto, asegúrese de tener todas las piezas. Monte sobre una superficie suave.

STEP 1

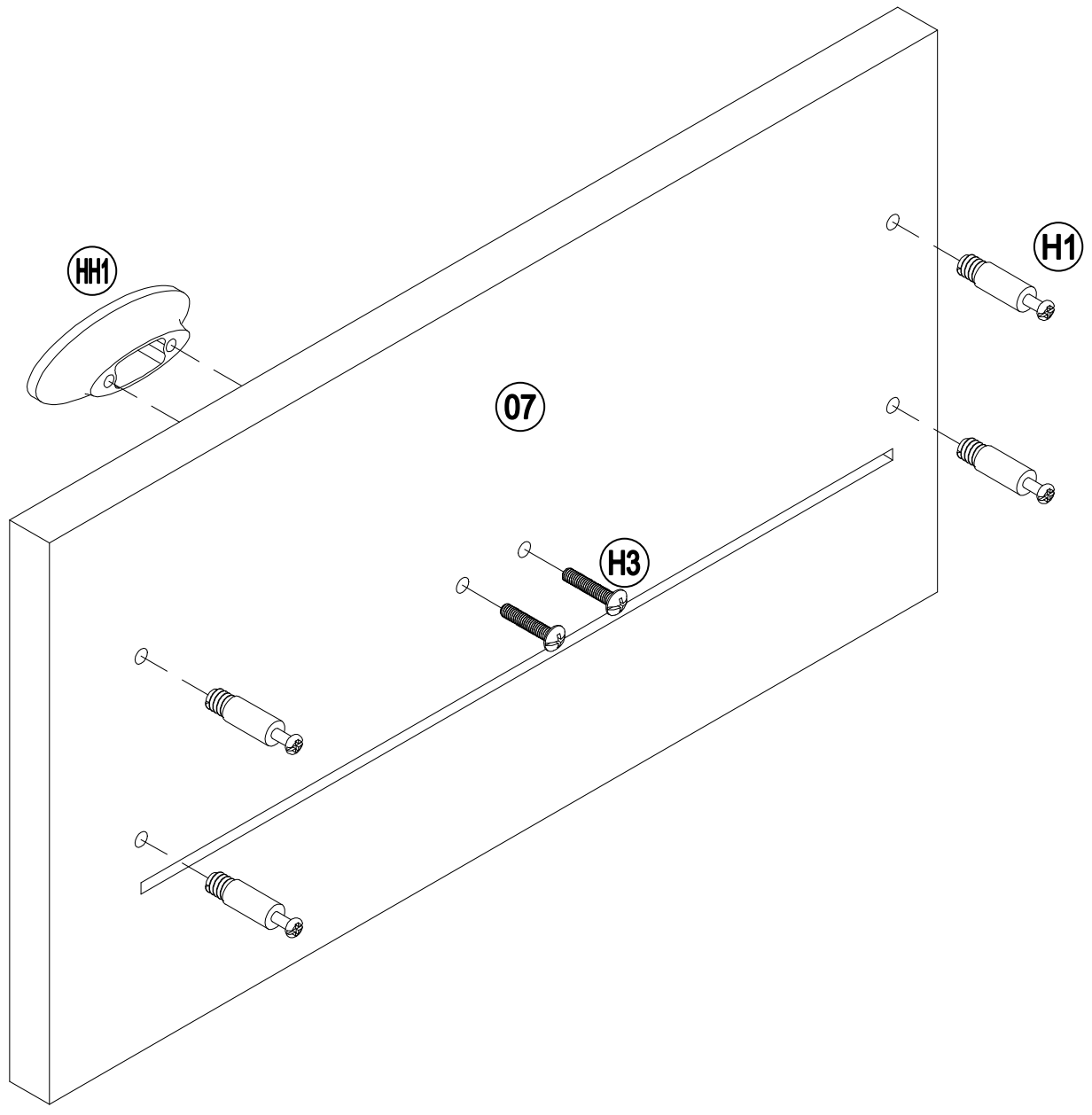
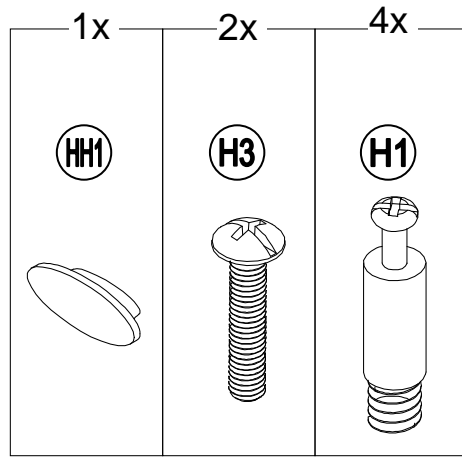
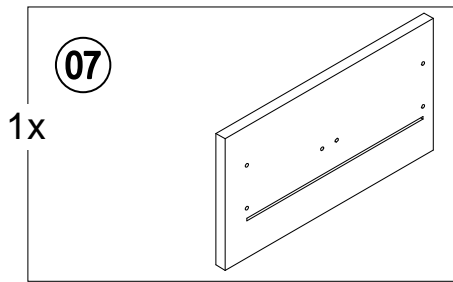

STEP 2

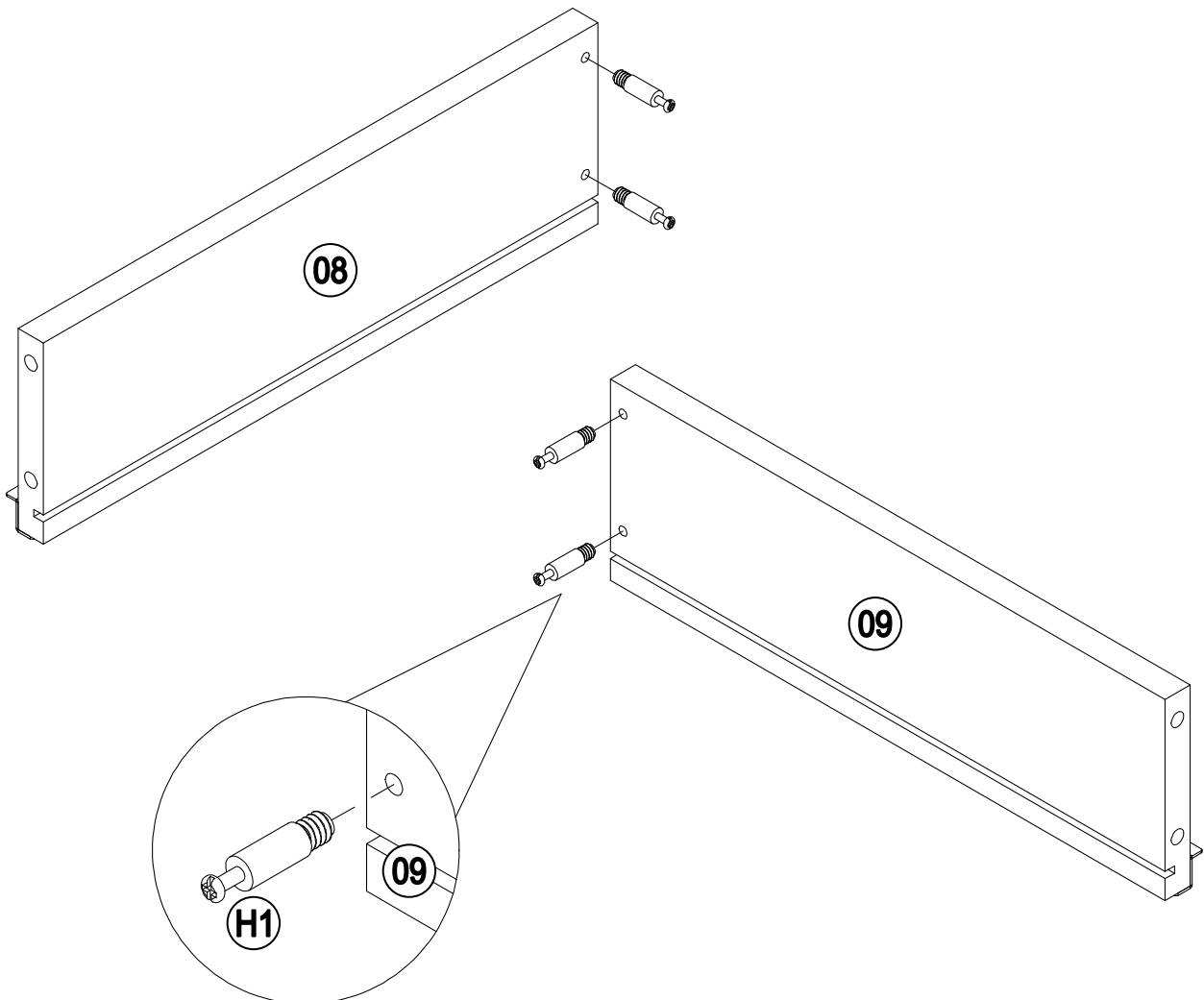
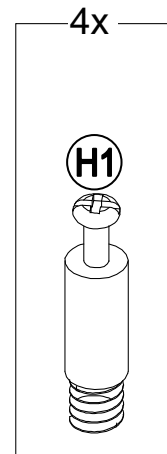
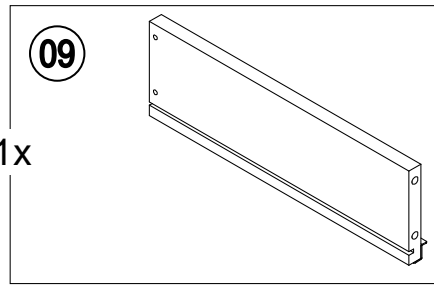
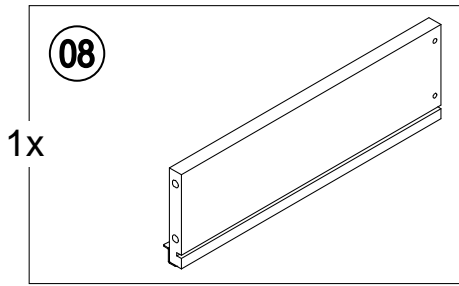

STEP 3

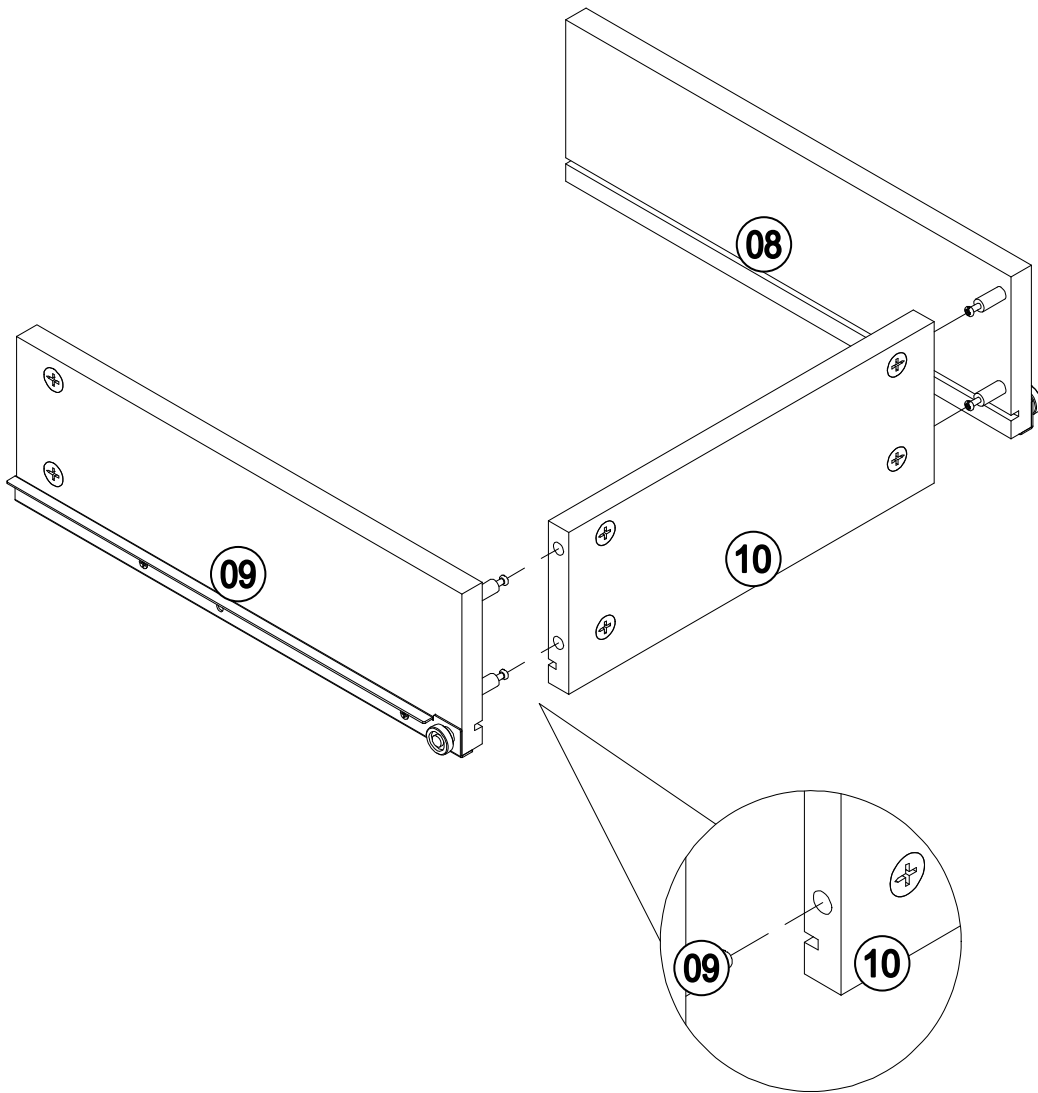
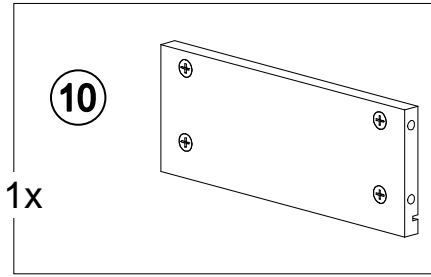

STEP 4

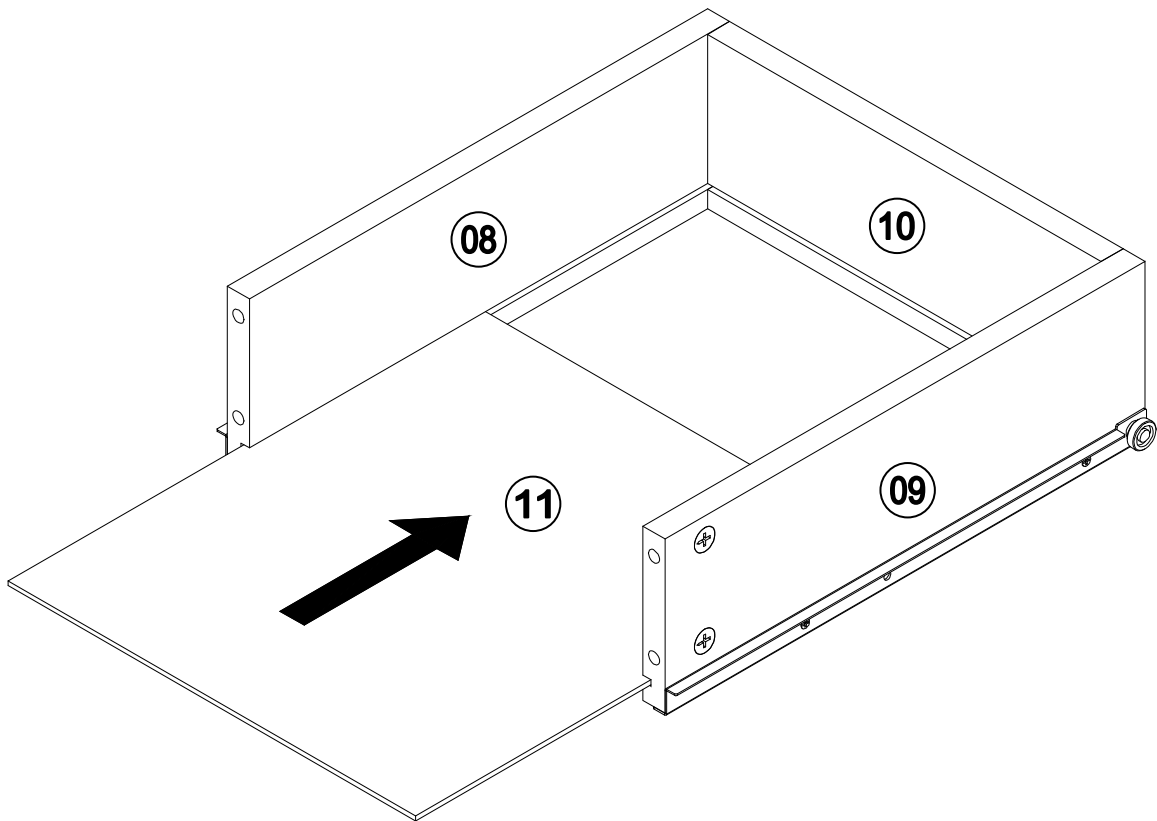
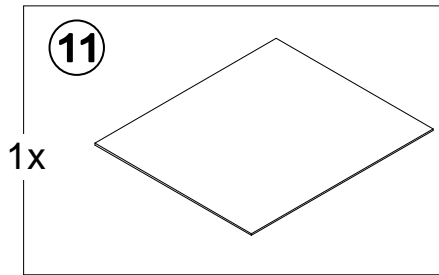

STEP 5

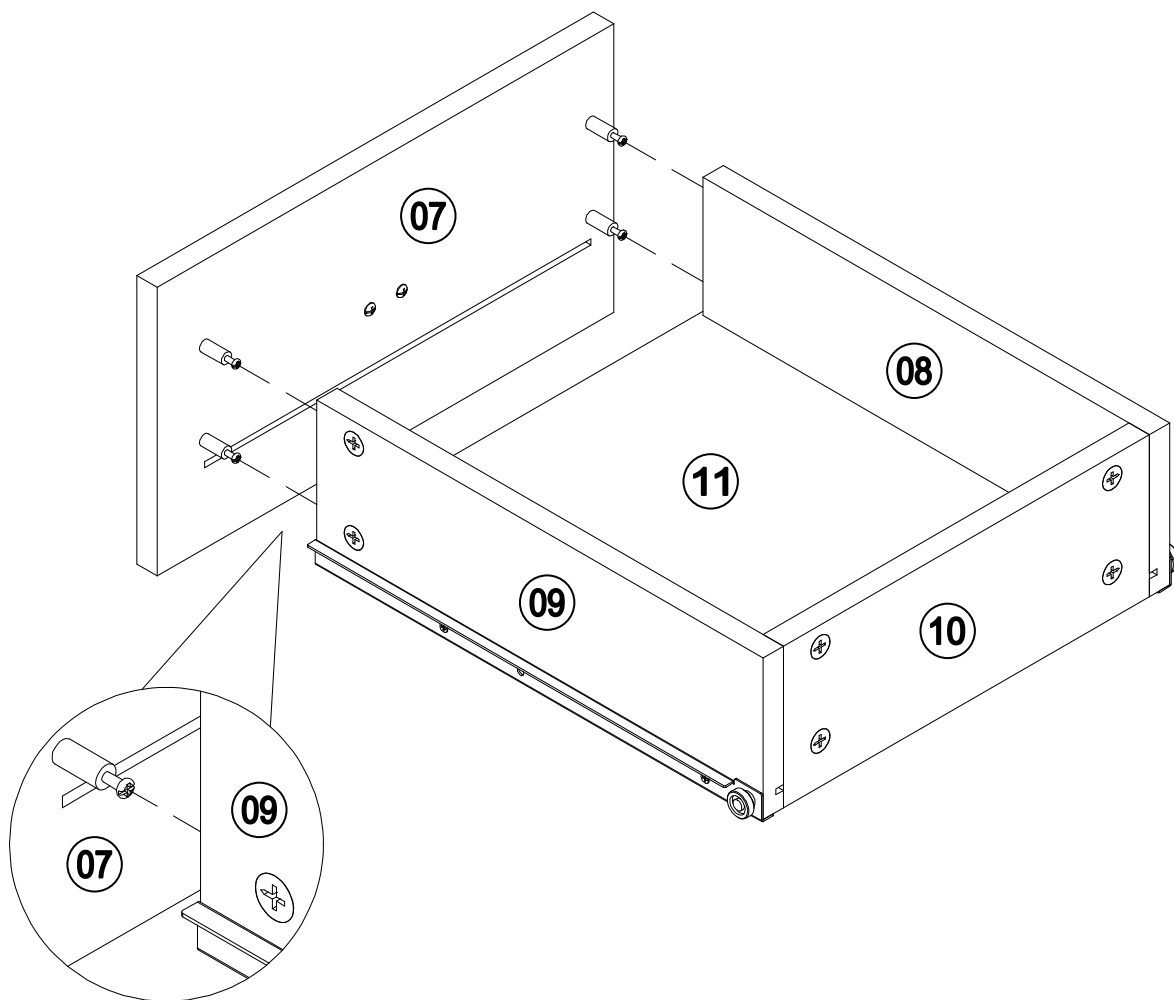

STEP 6

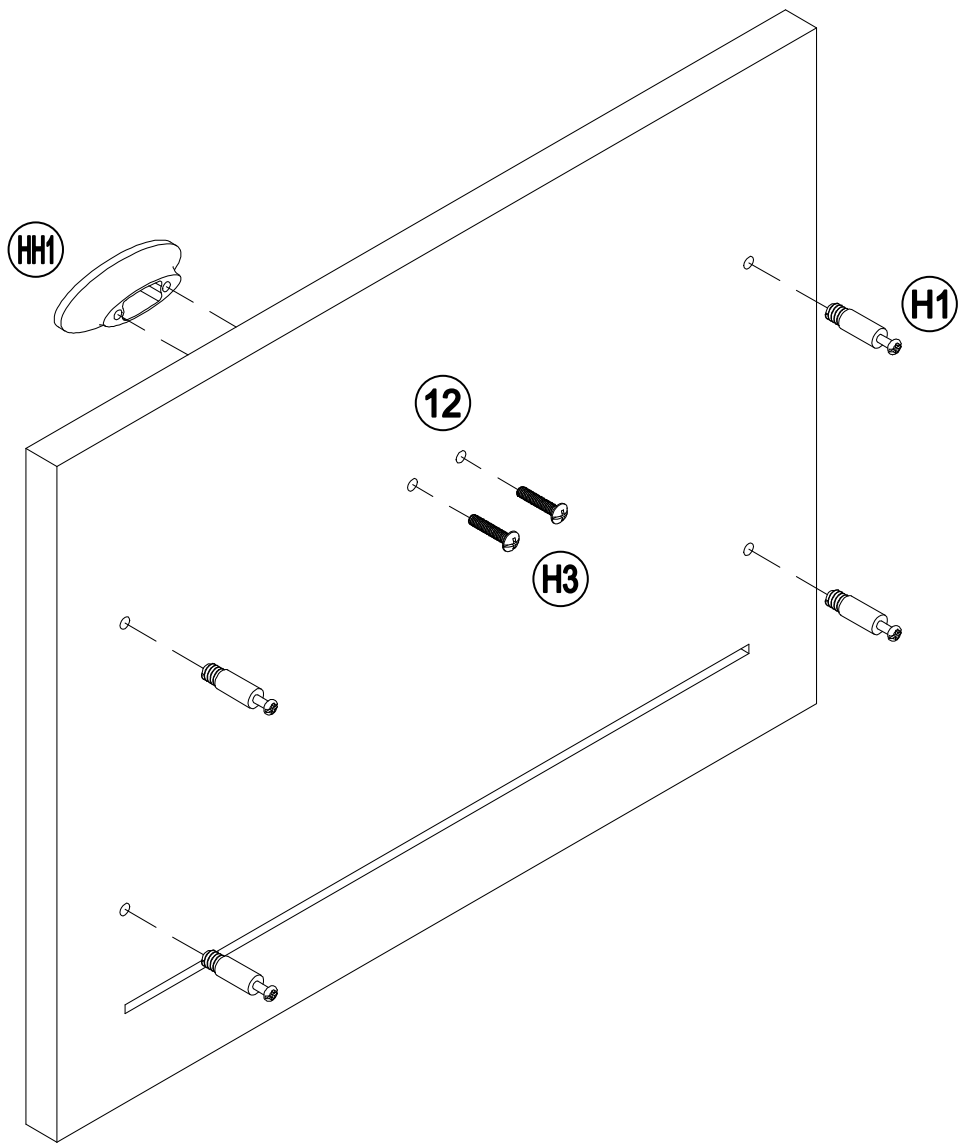
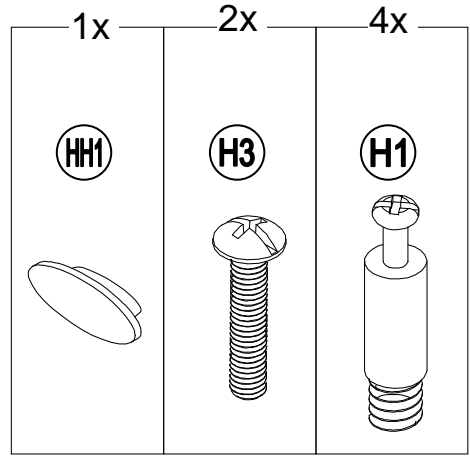
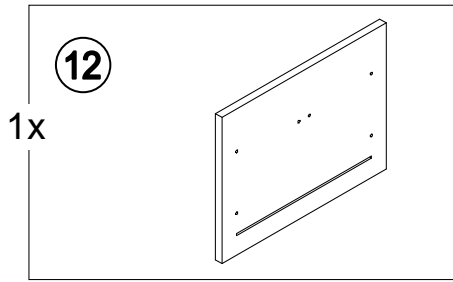

STEP 7

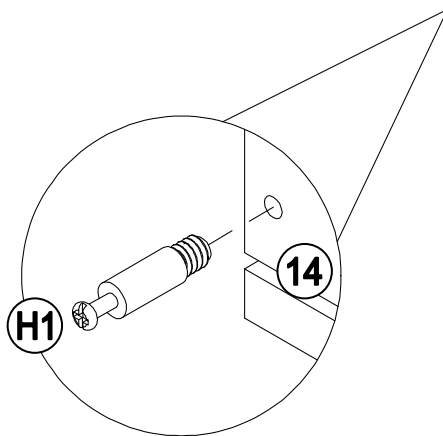
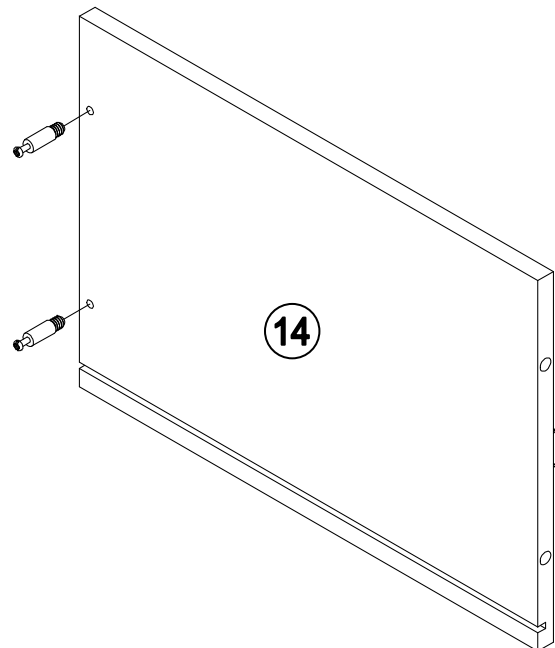
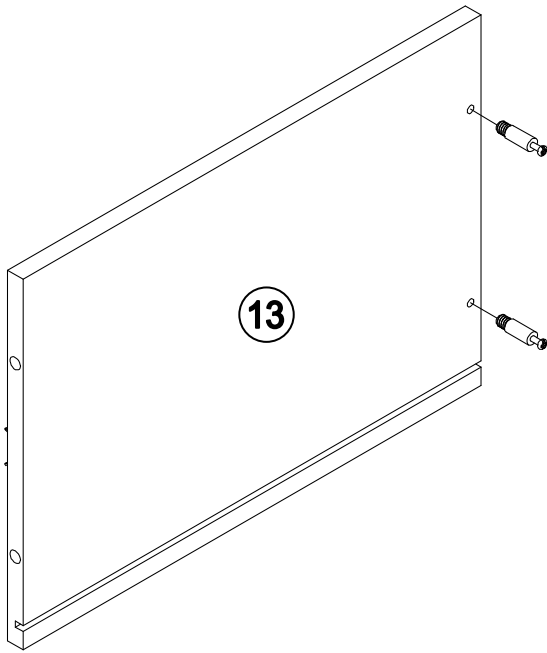
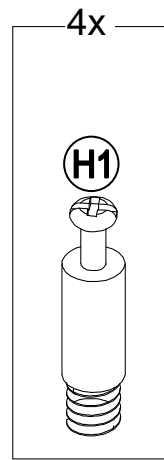
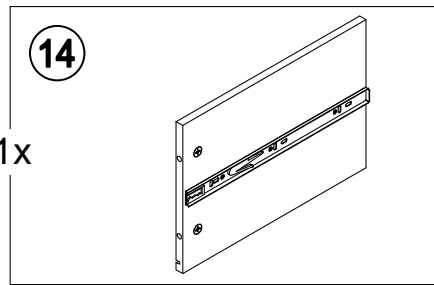
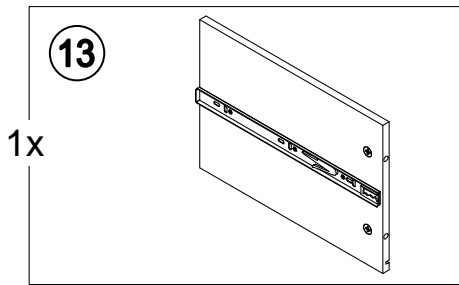

STEP 8

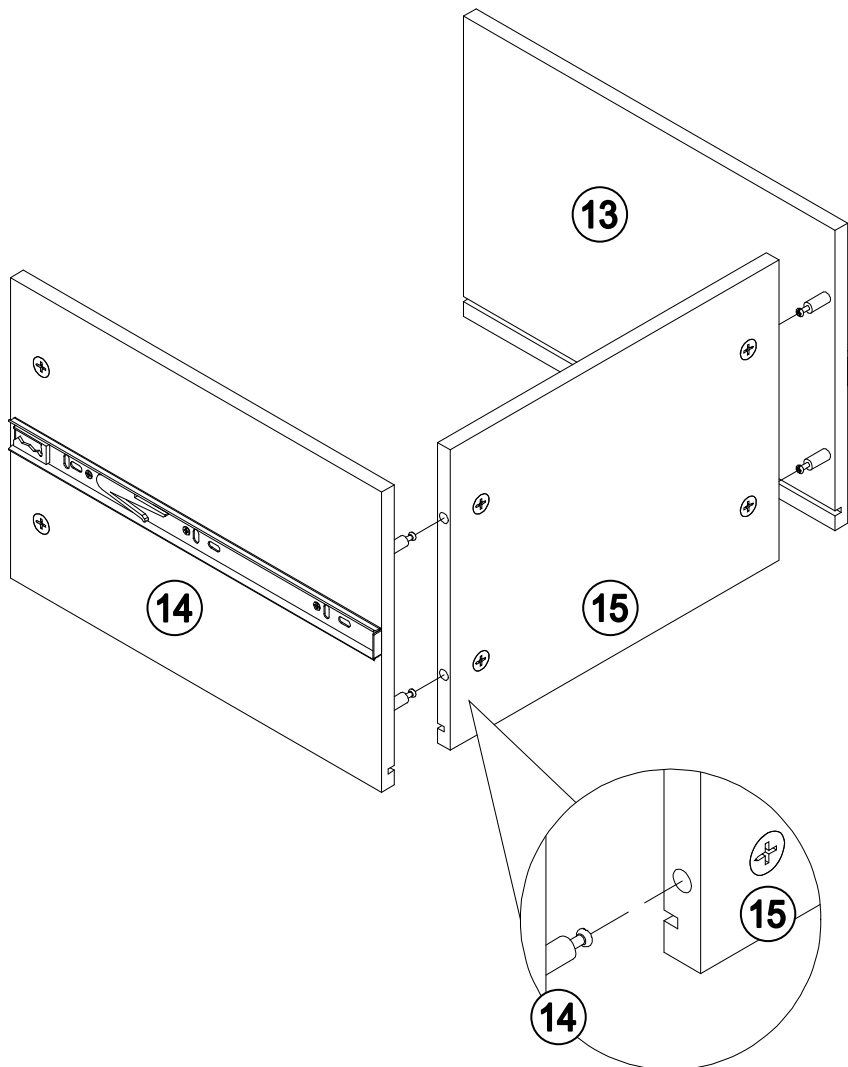
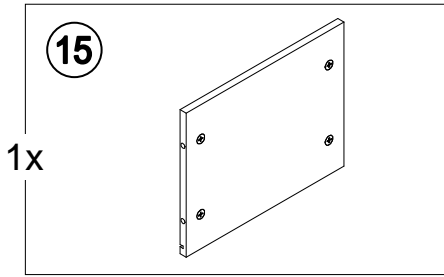

STEP 9

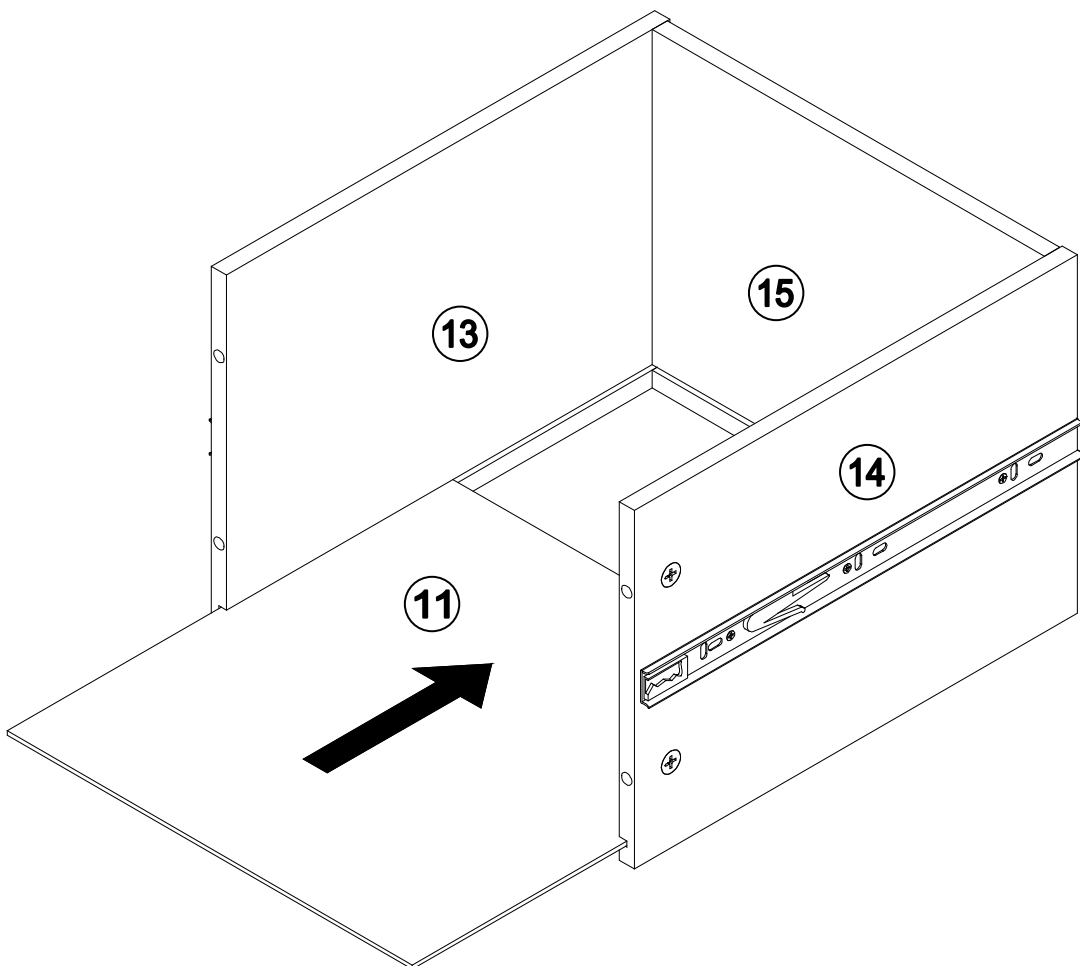
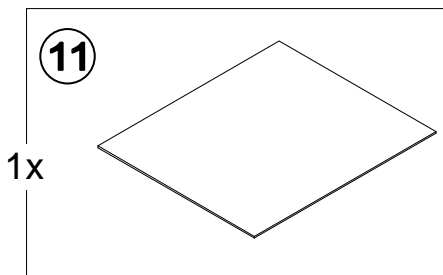

STEP 10

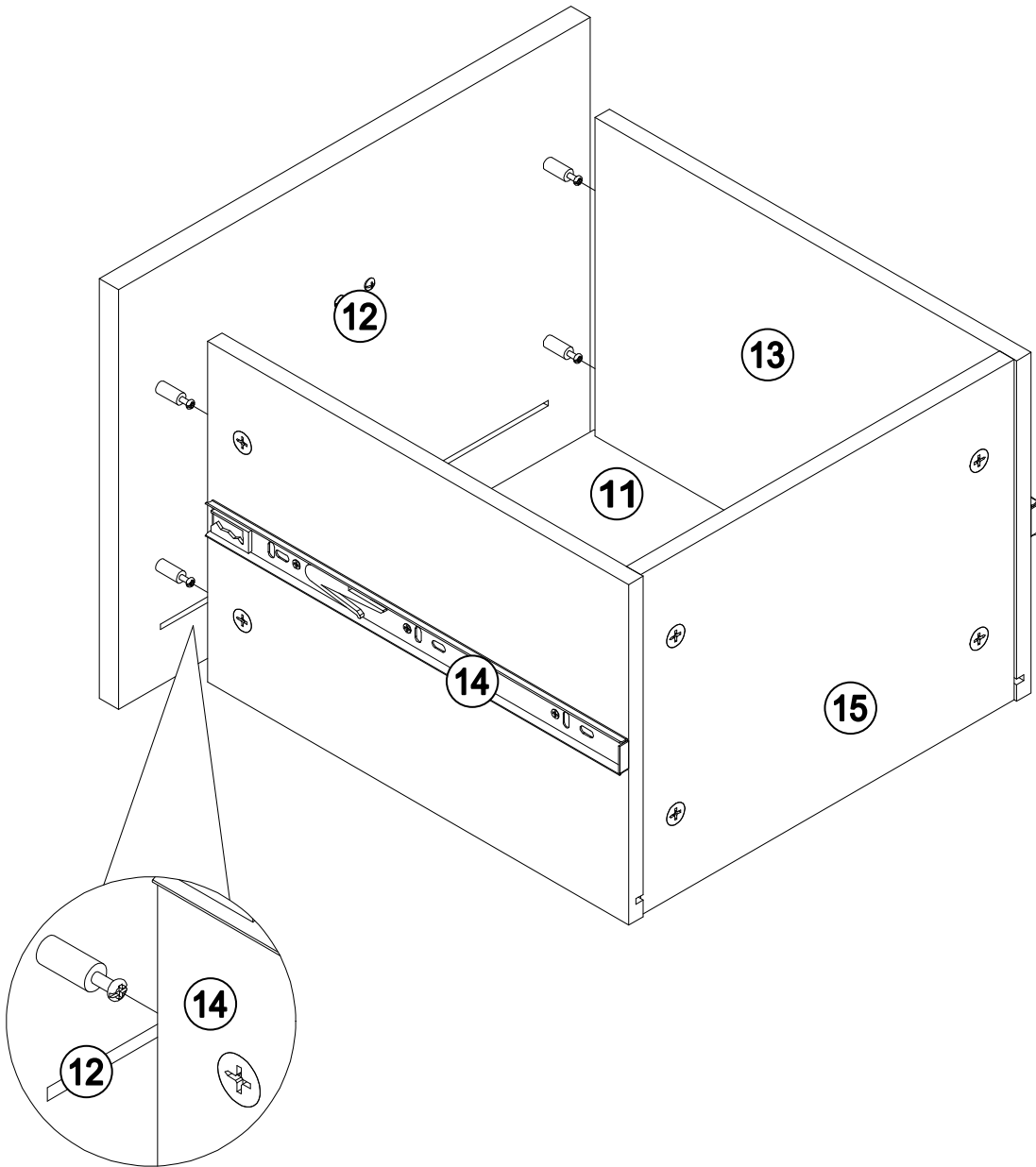

STEP 11

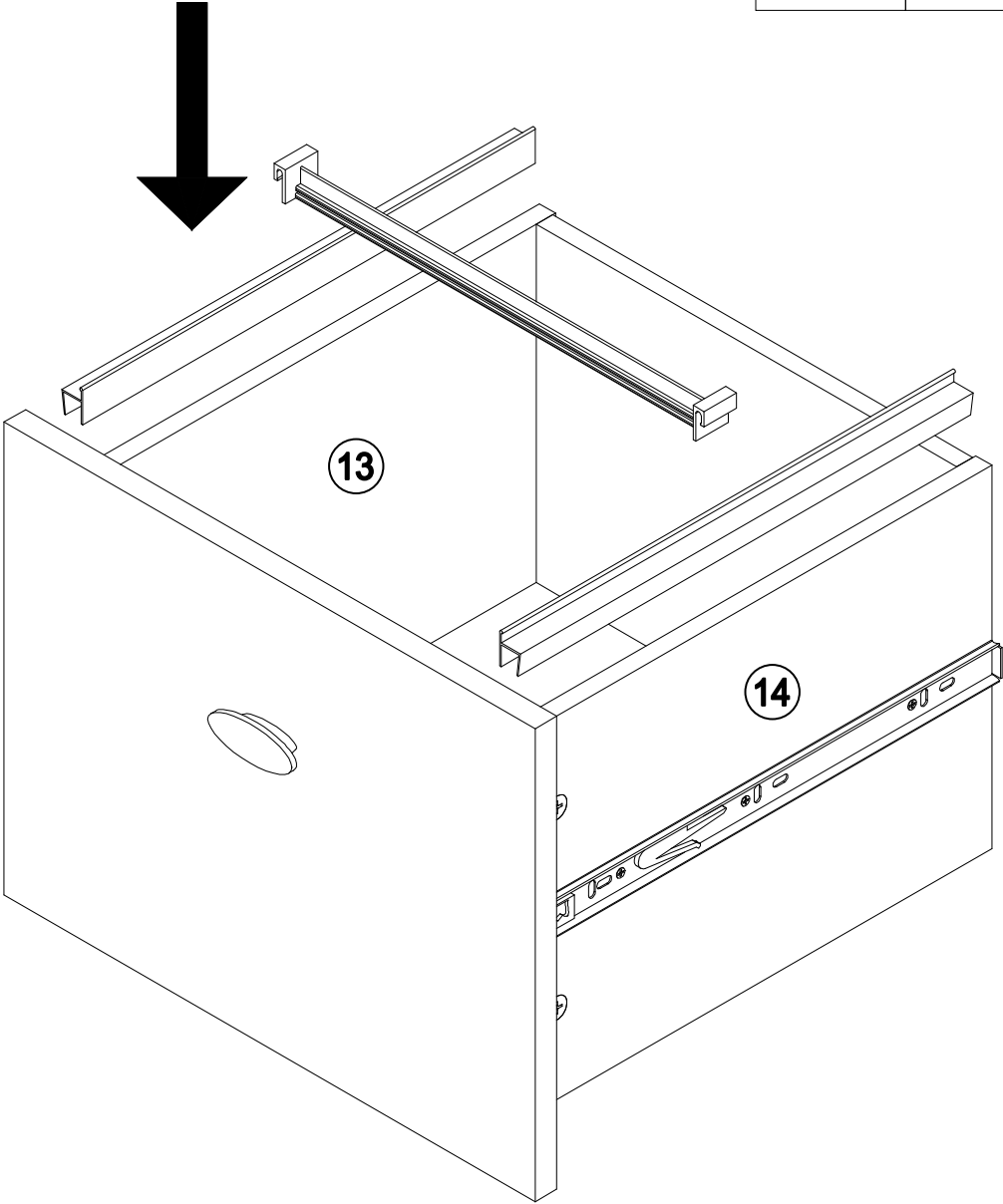
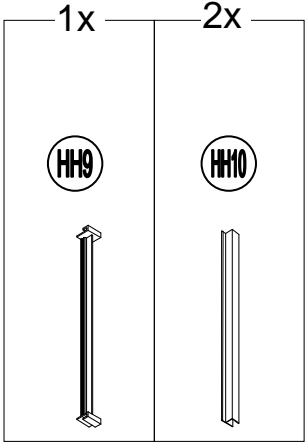

STEP 12

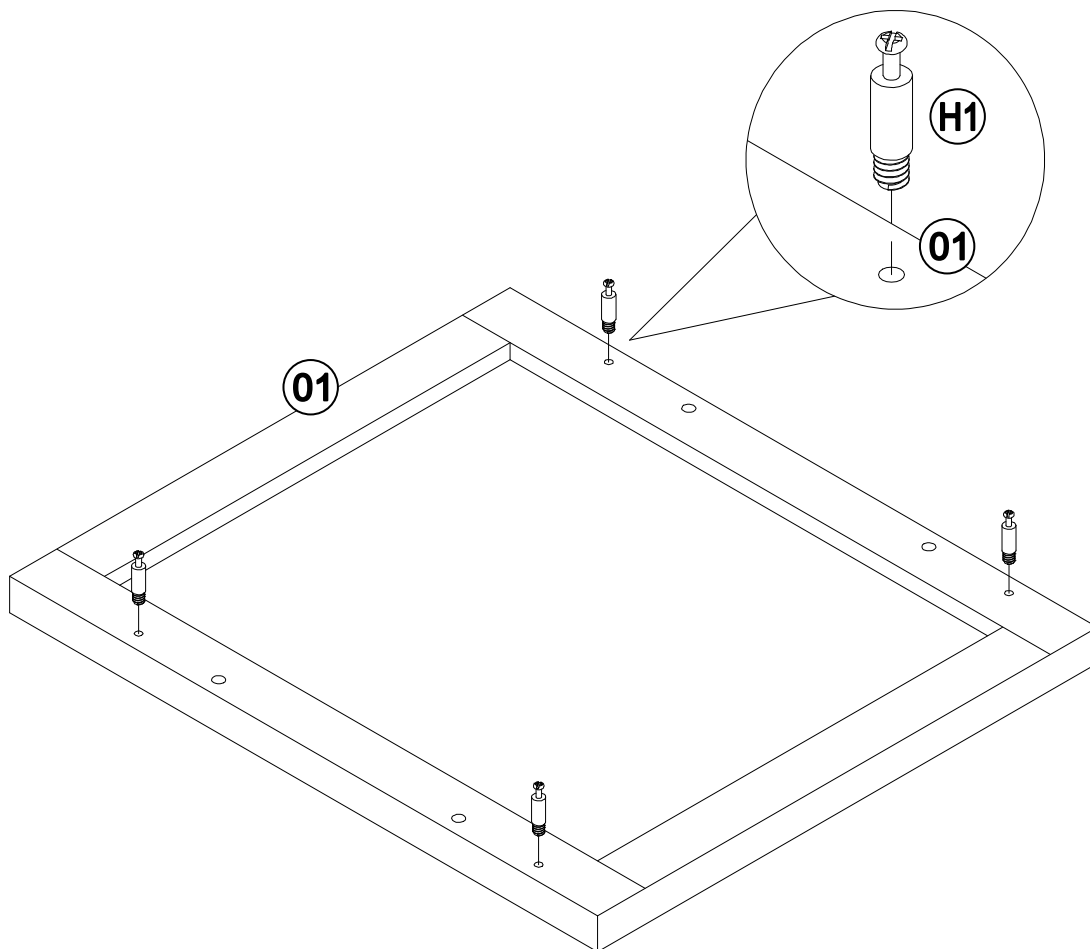
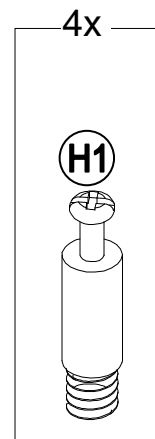
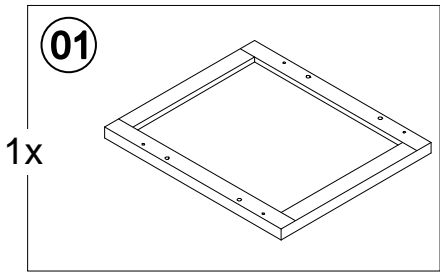

STEP 13

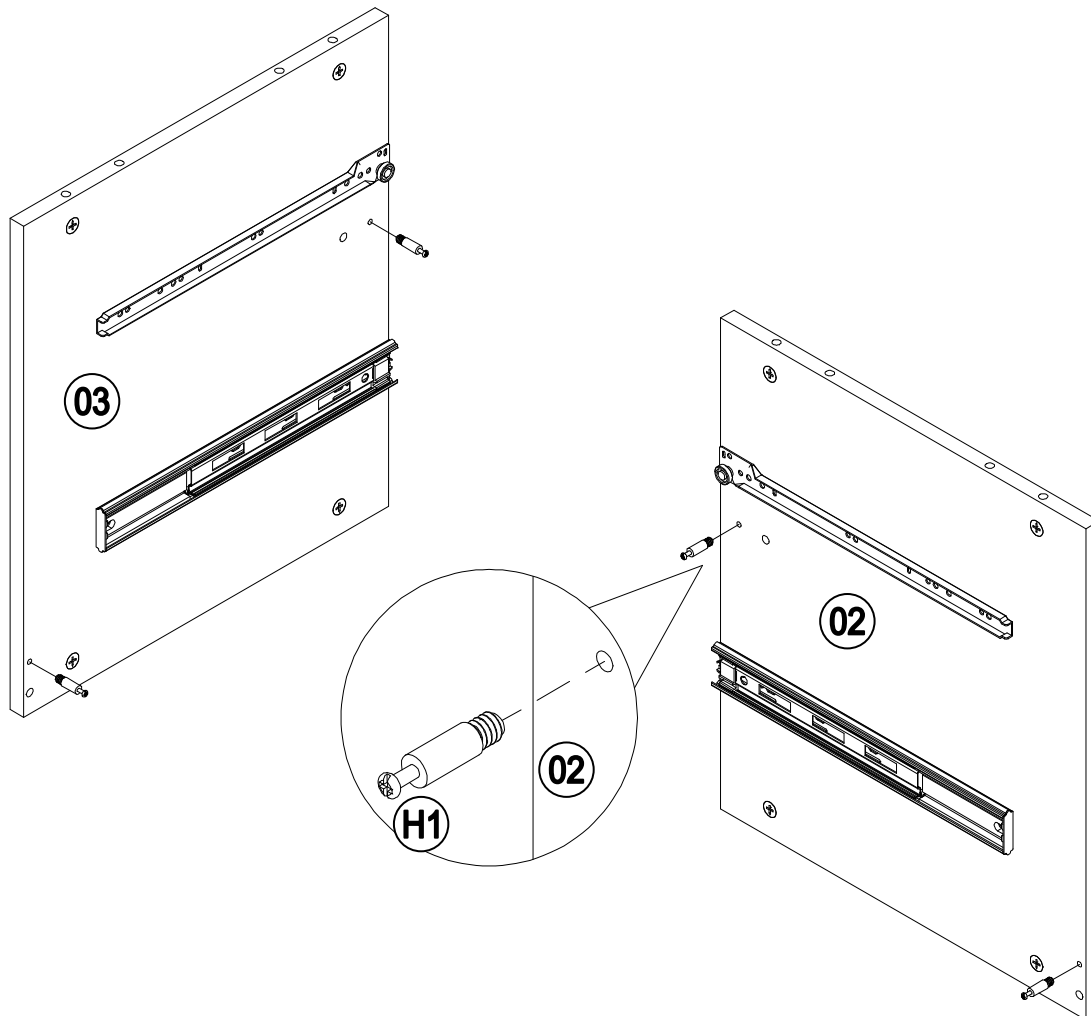
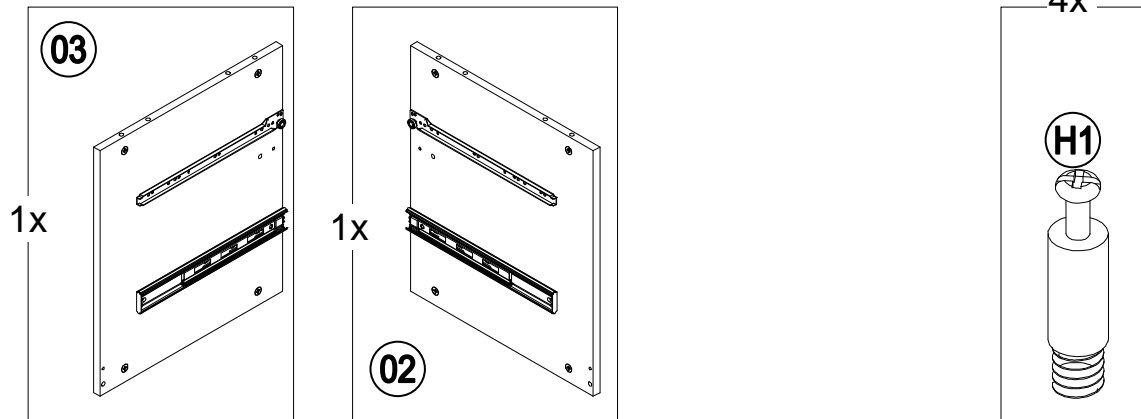

STEP 14

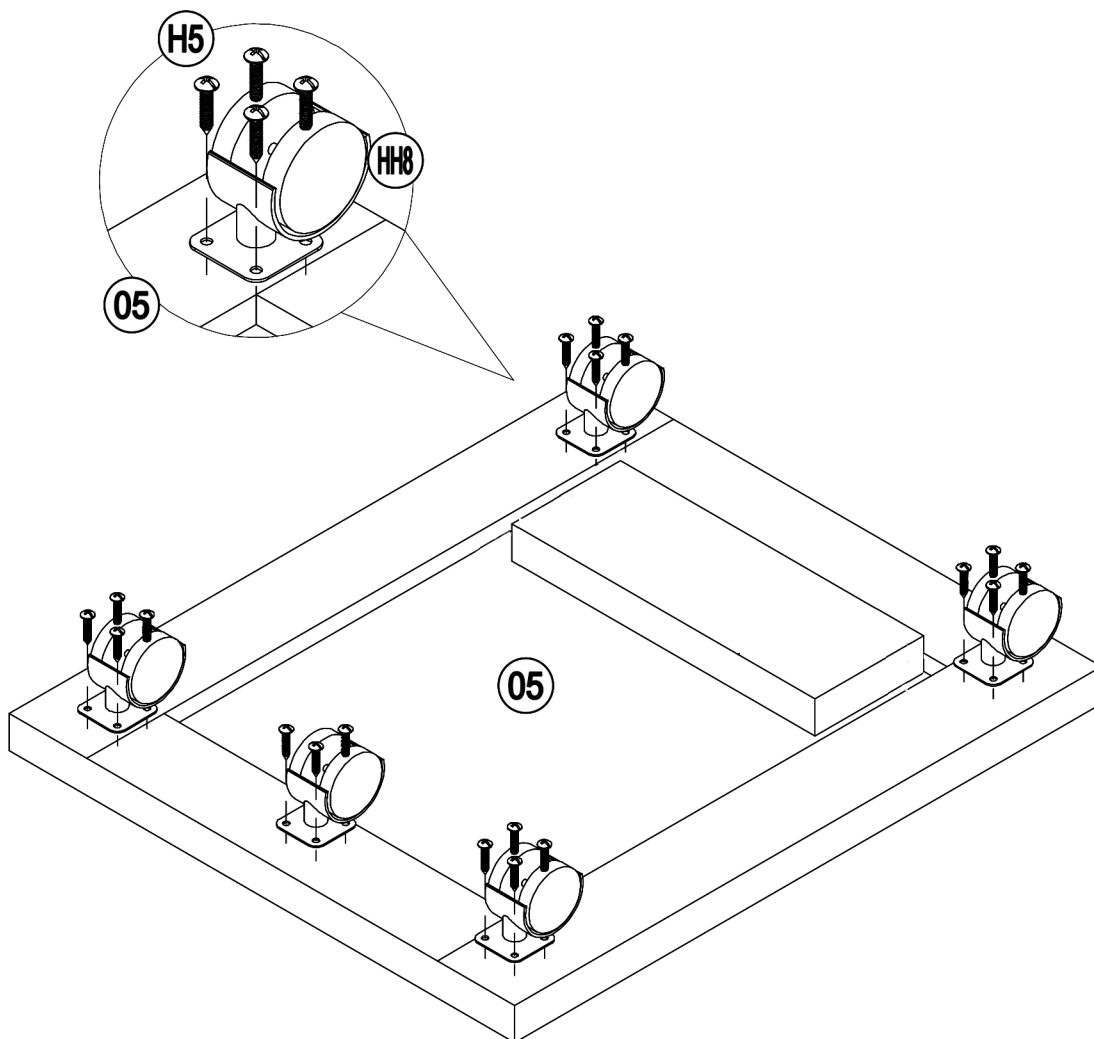
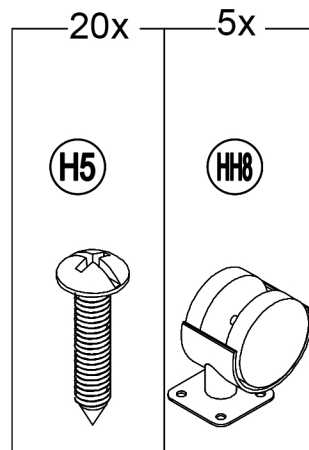
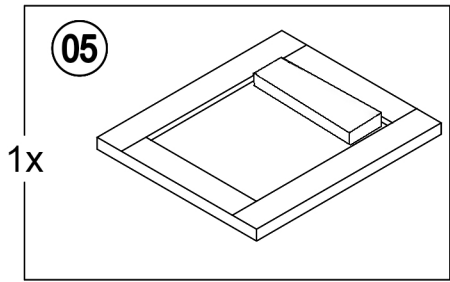

STEP 15

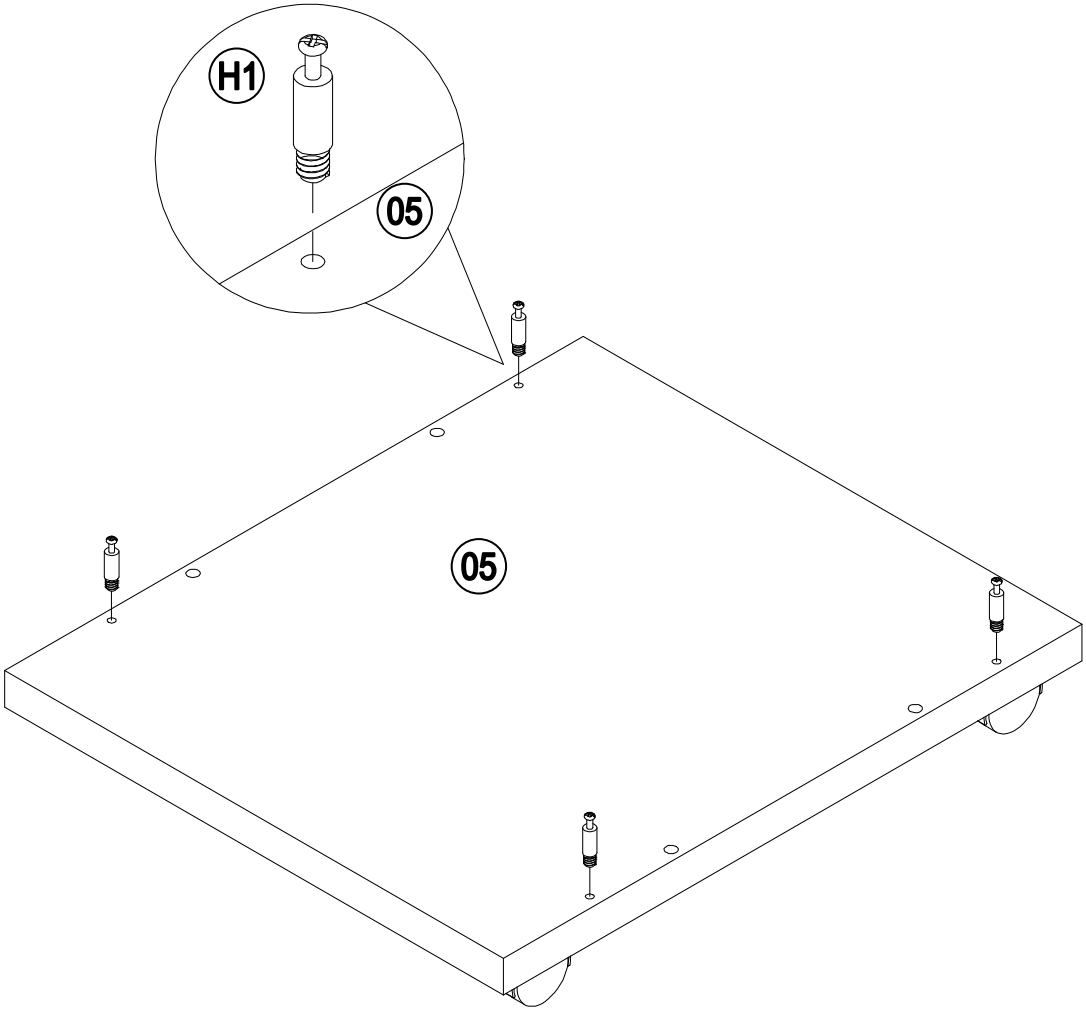
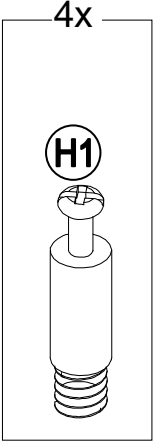

STEP 16

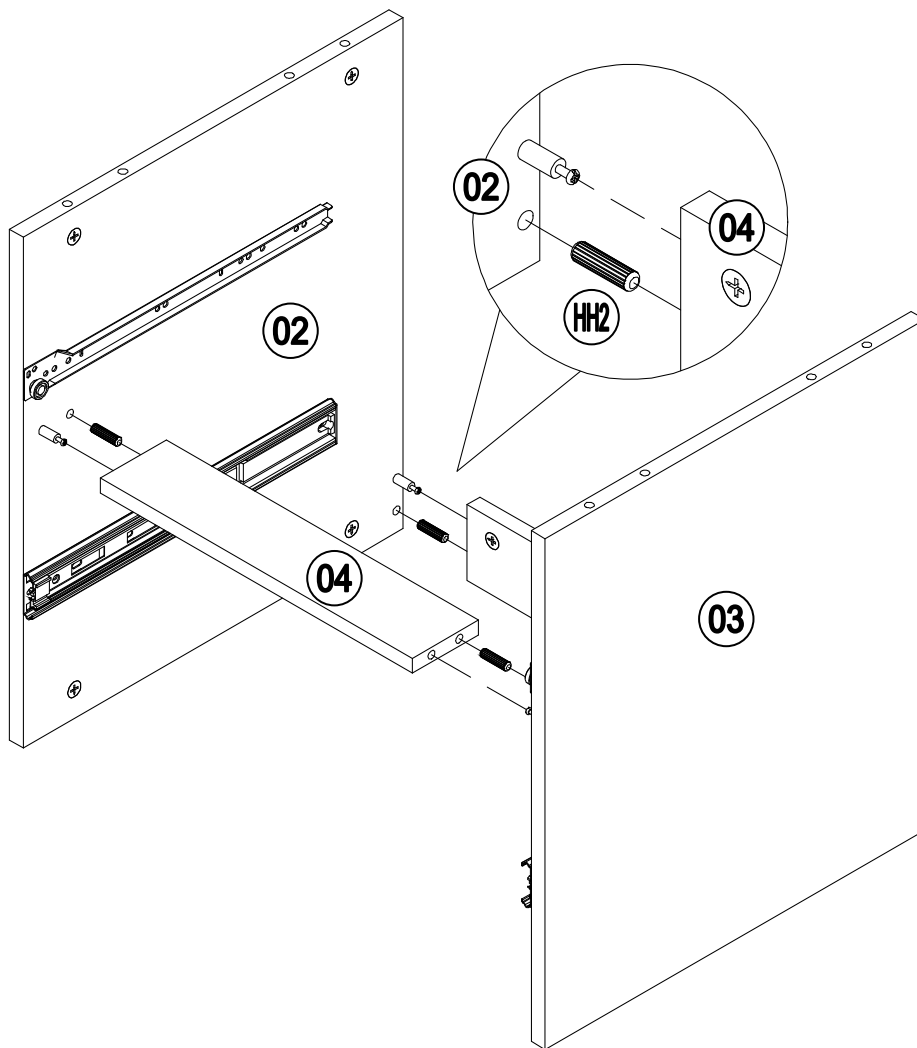
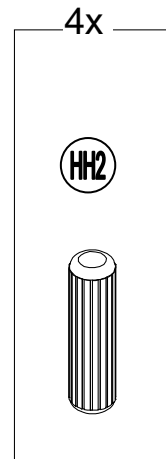
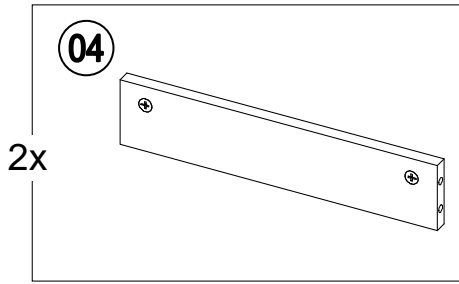

STEP 17

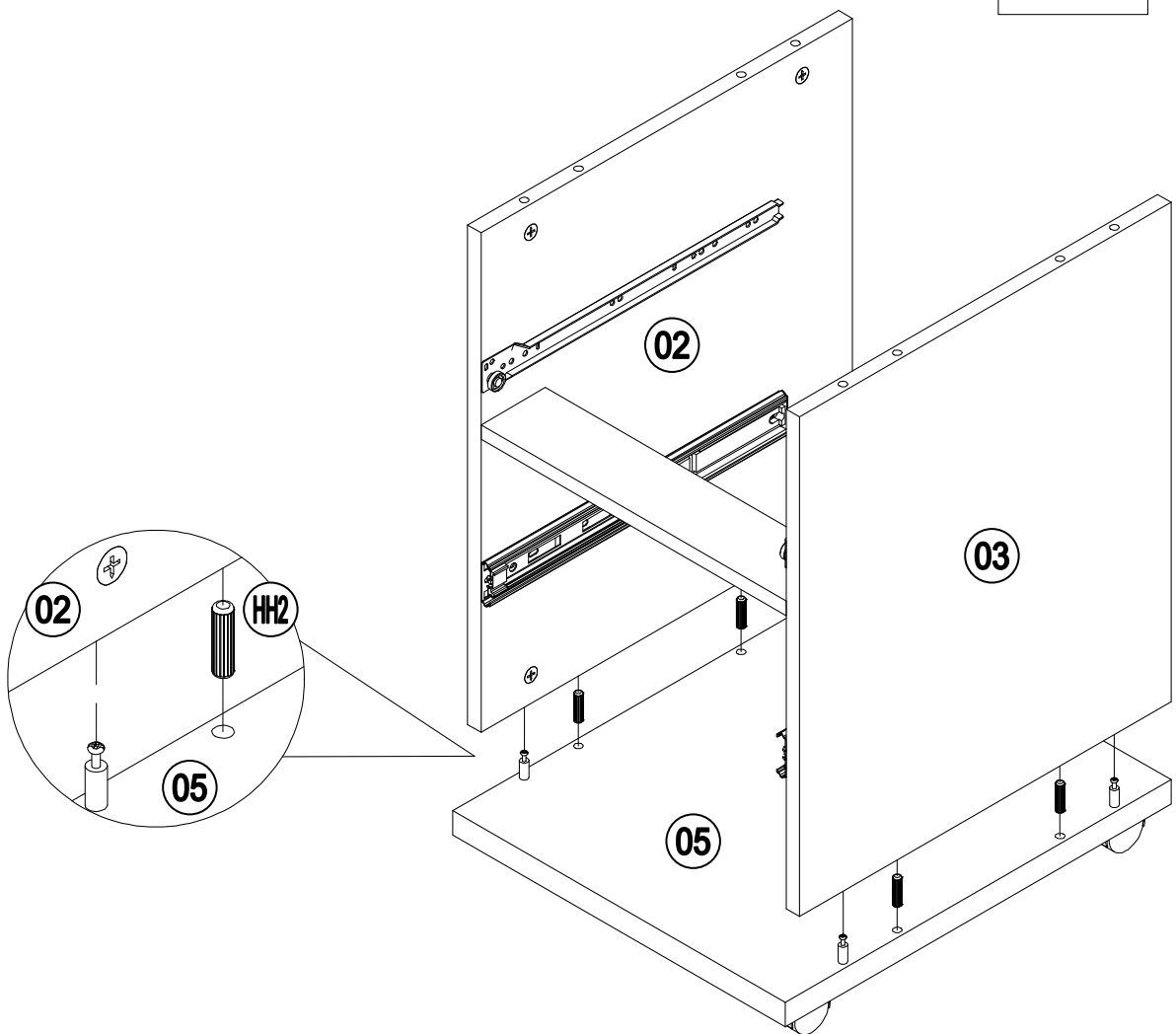
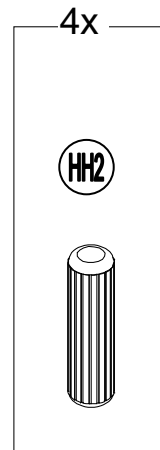

STEP 18

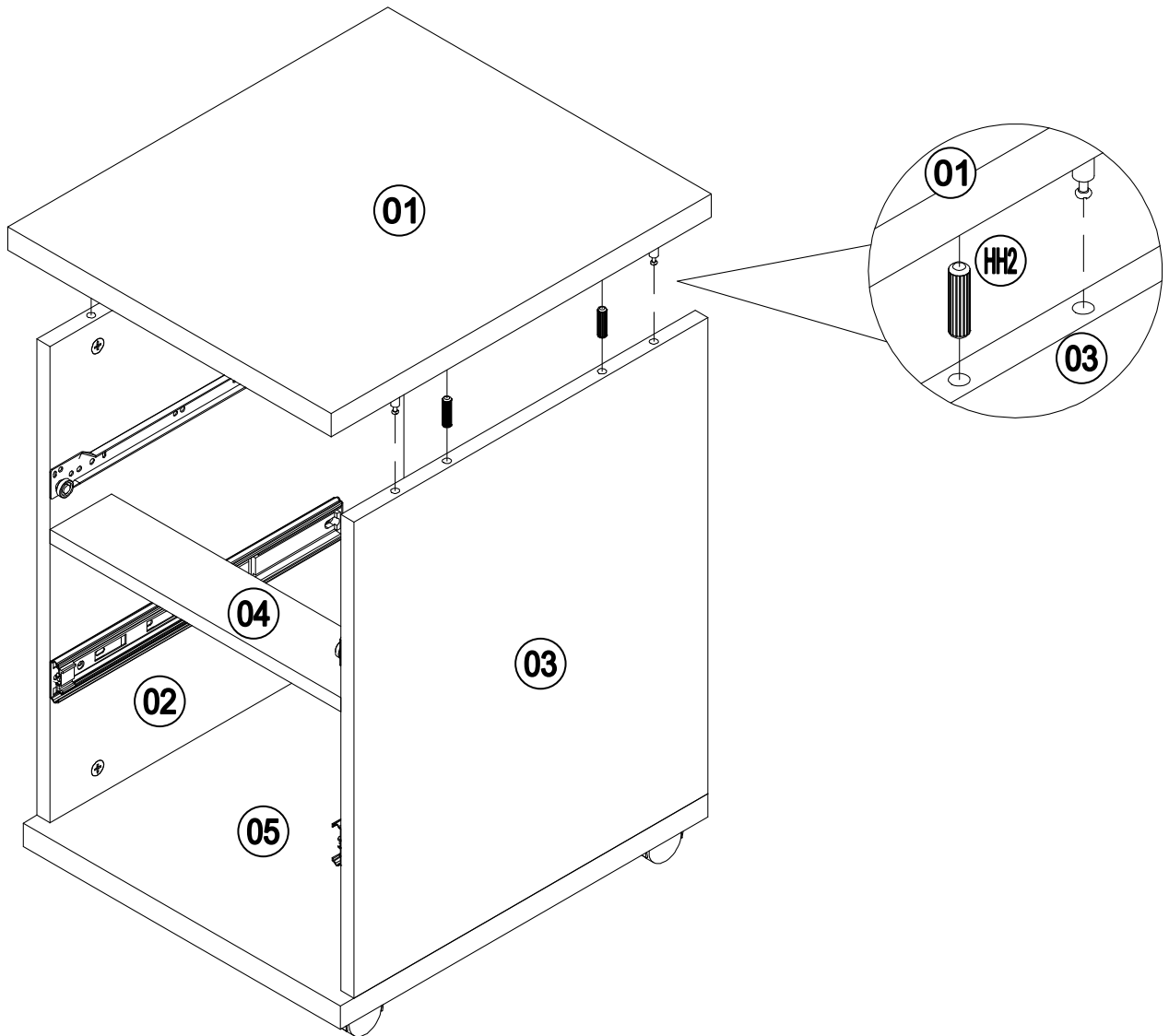
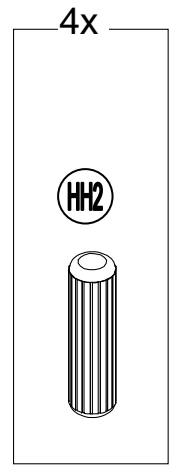

STEP 19

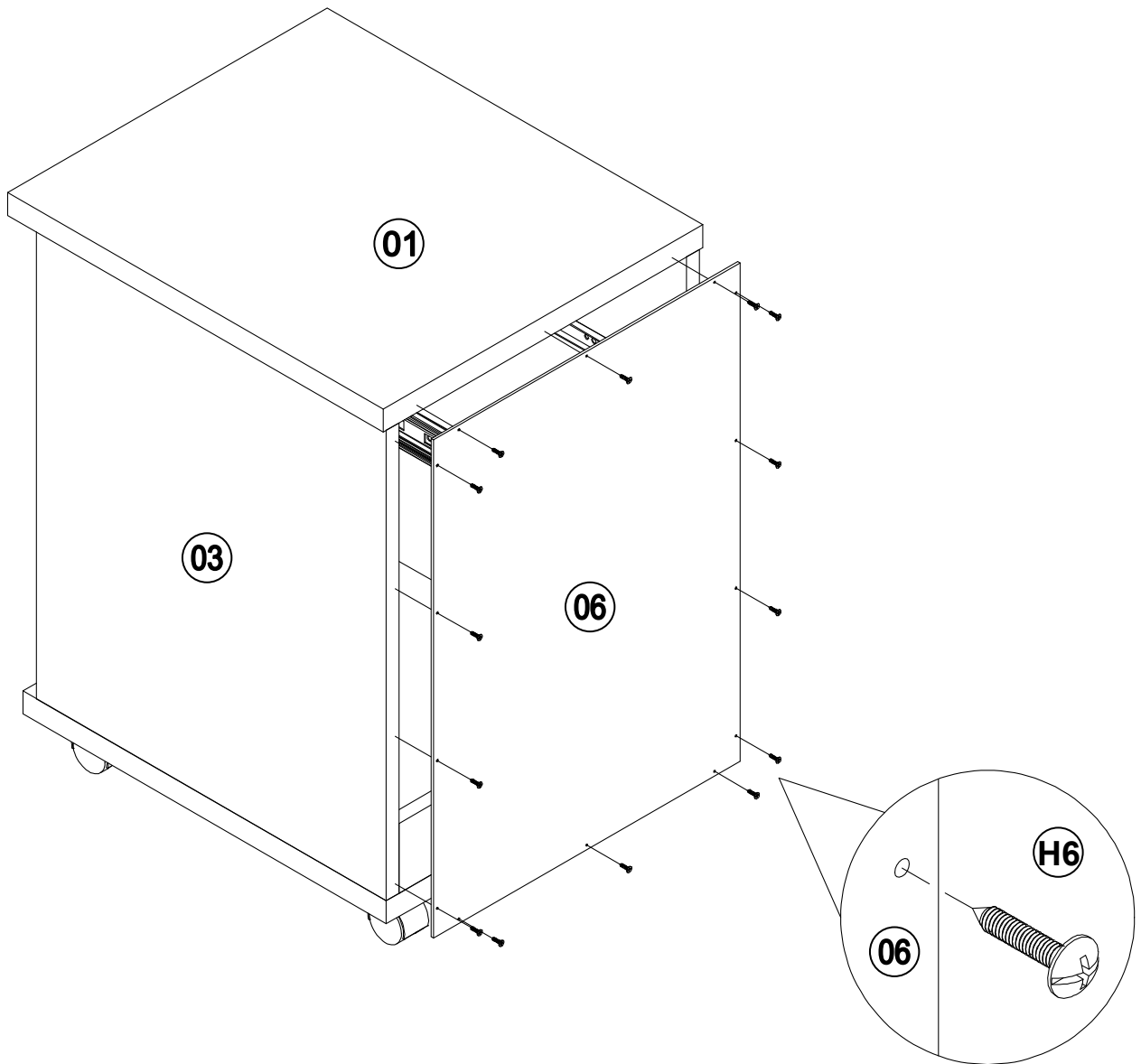
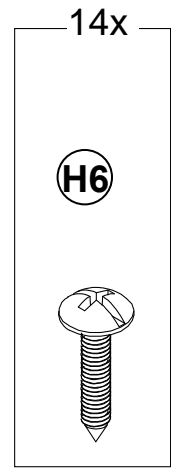
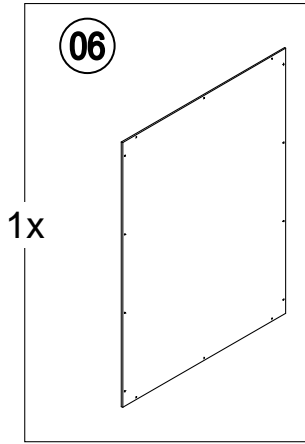

STEP 20

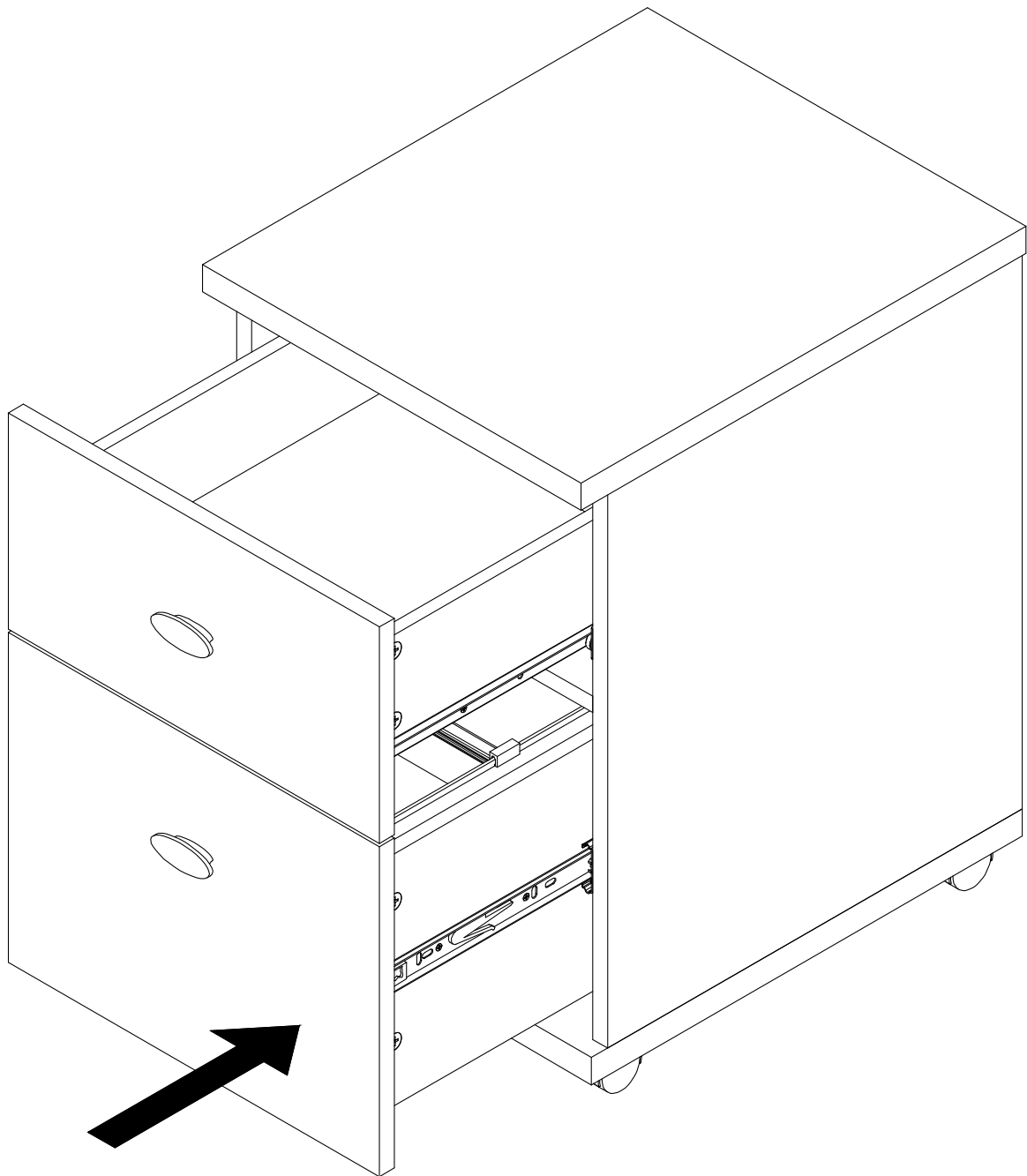

CARE AND MAINTENANCE / SOIN ET ENTRETIEN / CUIDADO Y MANTENIMIENTO

- Use a soft, clean cloth that will not scratch the surface when dusting.
- Using solvents of any kind on your furniture may damage the finish.
- Never use water to clean your furniture as it may cause damage to the finish.
- Liquid spills should be removed immediately. Using a soft, clean cloth, blot the spill gently. Avoid rubbing.
- Always use protective pads under hot dishes and plates. Heat can cause chemical changes that may create potting within the furniture finish.
- It is best to keep your furniture in a climate-controlled environment. Extreme temperature and humidity changes can cause fading, warping, shrinking and splitting of wood. It is advised to keep furniture away from direct sunlight as sun may damage the finish.
- Proper care and cleaning at home will extend the life of your purchase. Following these important and helpful tips will enhance your furniture as it ages.
- Utilisez un chiffon doux et propre qui ne va pas égratigner la surface quand vous faites la poussière.
- Vous pouvez endommager la finition de votre meuble si vous utilisez des dissolvants quelconques.
- N'utilisez jamais de l'eau pour nettoyer votre meuble pour éviter les dommages à la finition.
- Si vous renversez du liquide, nettoyez immédiatement. Utilisez un chiffon doux et propre et tamponnez délicatement la tache. Ne frottez pas.
- Utilisez toujours des coussinets protecteurs sous les plats et les assiettes chaudes. La chaleur peut causer un changement chimique qui peut créer des taches dans la finition du meuble.
- Il est préférable de garder votre meuble dans un environnement climatisé. Les températures extrêmes et l'humidité peuvent affaiblir, déformer, rétrécir, et fissurer le bois. Nous recommandons de garder le meuble hors de la lumière directe du soleil pour éviter les dommages à la finition.
- Les soins nécessaires et le nettoyage chez vous prolongera la vie de votre achat. Suivre ces conseils importants et utiles rehaussera votre meuble à mesure qu'il vieillit.
- Utilice un trapo suave y limpio que no vaya a arañar la superficie cuando limpia el polvo.
- Puede dañar el acabado de su mueble si utiliza cualquier disolvente.
- No utilice nunca agua para limpiar su mueble para evitar los daños al acabado.
- Si derrama algún líquido, límpielo inmediatamente. Utilice un trapo suave y limpio y dele toquecitos suaves a la mancha. No se debe restregar.
- Utilice siempre almohadillas protectoras bajo los platos y vajilla calientes. El calor puede causar un cambio químico que puede provocar manchas en el acabado del mueble.
- Es preferible guardar su mueble en un entorno climatizado. Las temperaturas extremas y la humedad pueden atenuar, deformar, estrechar y rajar la madera. Se recomienda guardar el mueble fuera de la luz directa del sol para evitar daños al acabado.
- Los cuidados y limpieza adecuada en su casa pueden alargar la vida de su compra. Seguir estos consejos importantes y útiles realzará su mueble a medida que los años pasan.

ONE-YEAR LIMITED WARRANTY / GARANTIE LIMITÉE DE UN AN / UN AÑO DE GARANTÍA LIMITADA

This limited warranty is extended to the original purchaser and applies to defects in material and workmanship of your item provided the item is maintained with care and used only for personal, residential purposes. The manufacturer warrants this item is free of defects in material and workmanship for a period of one year. If any defect is found, please email at customer.care@sunjoygroup.com for help. The manufacturer will not cover transportation or delivery costs or compensate the individual or any outside party for assembling or disassembling the product.

Cette garantie limitée ne s'applique qu'à l'acheteur original et aux défauts en matériel et en main d'oeuvre de votre produit, à condition que l'article a été maintenu avec soin et utilisé uniquement pour emploi personnel et résidentiel. Le fabricant garanti que cet article n'a aucun défaut matériel et de main d'oeuvre pendant une période de deux ans. Si vous trouvez un défaut, veuillez email à customer.care@sunjoygroup.com pour de l'aide. Le fabricant ne couvre pas pour frais de transport ni de livraison et n'indemnise ni l'individu, ni n'importe quelle autre personne pour le montage et démontage du produit.

Esta garantía limitada se concede al comprador original y se aplica a defectos materiales y de mano de obra de su producto, siempre y cuando el artículo haya sido mantenido con cuidado y utilizado solo para uso personal y residencial. El fabricante garantiza que este artículo no tiene ningún defecto material y de mano de obra durante un periodo de dos años. Si encuentra algún defecto, llame, por favor, por correo E a staples@sunjoygroup.com para que le ayuden. El fabricante no cubre por los gastos de transporte o de entrega, ni compensa al individuo o cualquier otra persona por el montaje o desmontaje del producto.