



MANUFACTURED BY:
Backyard Discovery
3305 Airport Drive, Pittsburg, KS 66762
800-856-4445

Basepoint Business Centre: Rivermead Drive, Westlea, Swindon SN5 7EX Phone: 0800-118-2476
J.P. Coenstraat 7, The Hague, 2595 WP, Netherlands Phone: 0800-567-8990

14x10 PERGOLA

Model # 1802513

The assembly manual must be retained
since it contains important information



Please visit www.backyarddiscovery.com

For the most up to date assembly manual, to register your set, or to order replacement parts

Para obtener instrucciones en español, visite www.backyarddiscovery.com



EASY STEP-BY-STEP
3D INTERACTIVE INSTRUCTIONS
DOWNLOAD THE FREE APP



Made in China

INS-1802513-A-14x10 PERGOLA-ENG 5-15-24

Owner's Manual - Basic Setup Dimensions & Assembly Notes

It is critically important that you start with square and level footings, concrete pad or deck to attach your structure

- Pay close attention to the items needed for each step. Make sure you are using the correct hardware for each step. Using incorrect hardware may result in improper assembly
- Remember to double check for underground utilities and overhead electrical lines

Post mounts are provided with your structure which allows you to permanently install your structure to a pre-existing or new wood or concrete surface.

- The hardware to attach the post mounts to the structure is included.
- The hardware to mount the structure permanently to a concrete surface is included.
- The hardware to mount the structure permanently to a wood deck is NOT included and will need to be purchased separately. **You must ensure there is ample structural support under the deck before permanently attaching.**

Metal Roof Assembly

Remove plastic covering from metal roof panels before installing each piece. Place roofing materials on a nonabrasive, flat surface before and after assembly as it could bend, dent or scratch

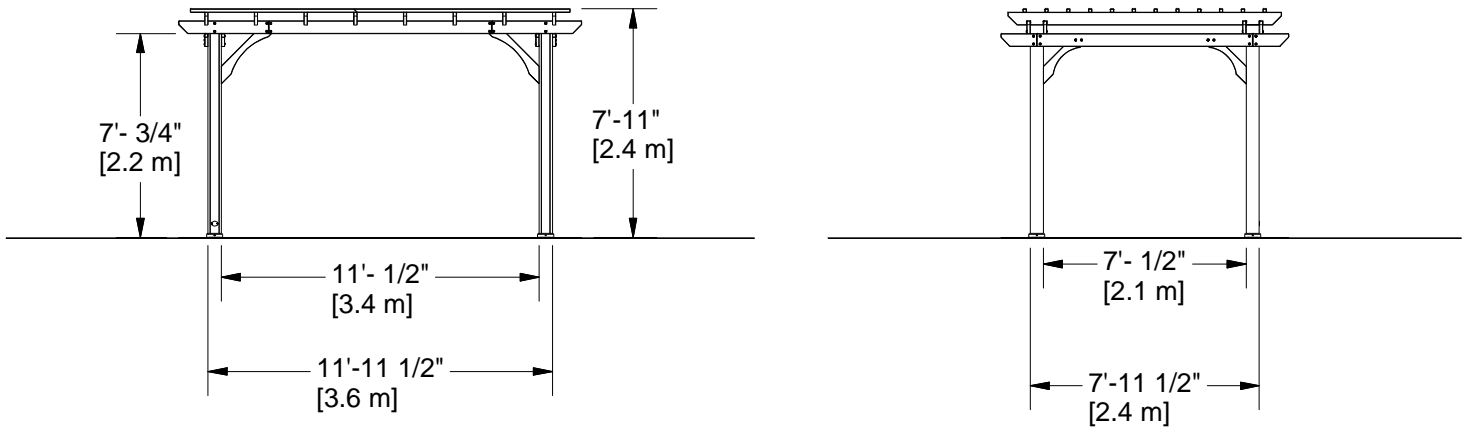

Owner's Manual - Anchoring Layout

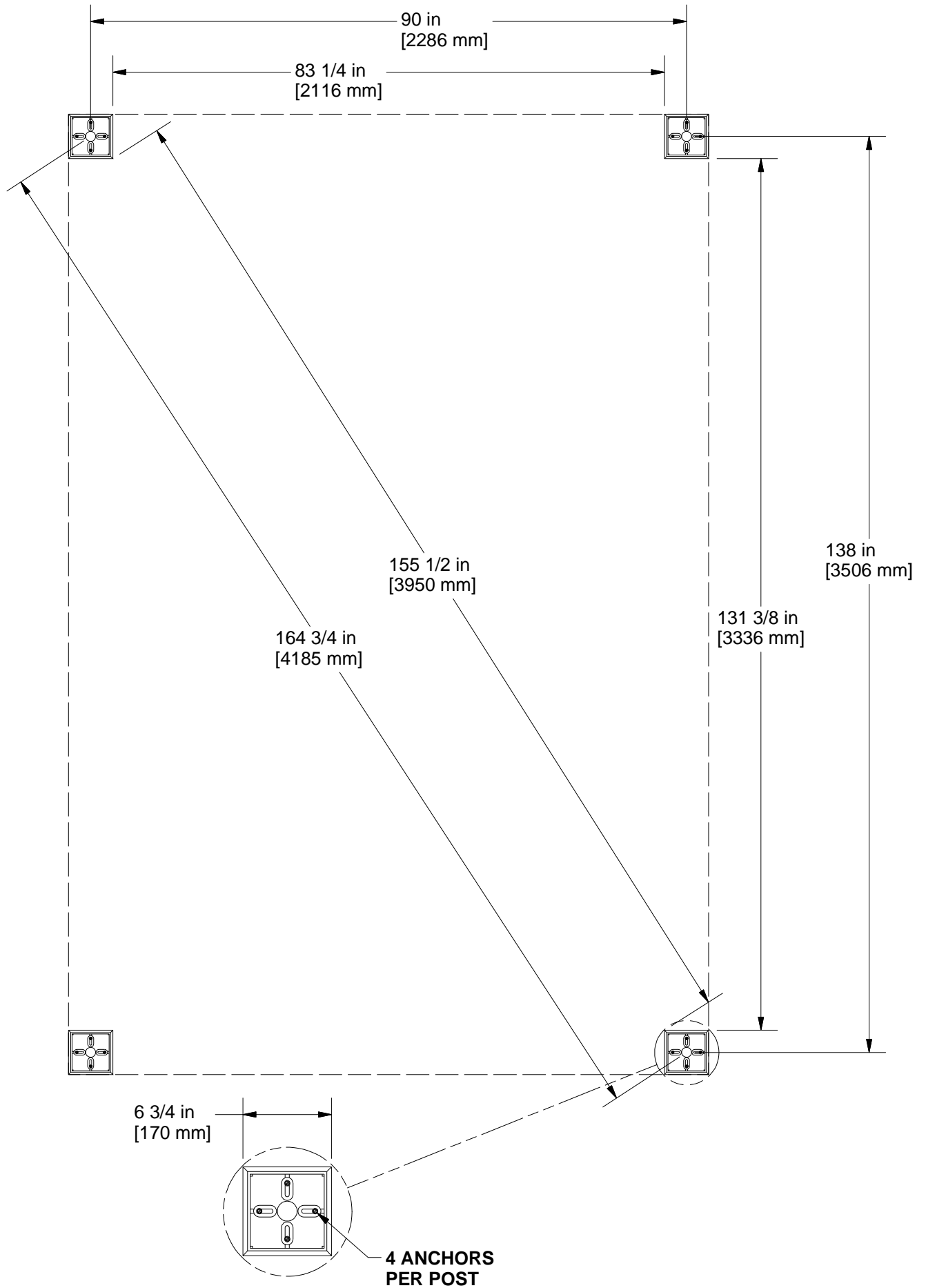

Owner's Manual - Parts Identification

Wood Components (Not to Scale)



D1 JOIST - W4L11635

(x2) 1 3/8"x5 1/4"x92 7/8" (36x134x2360)

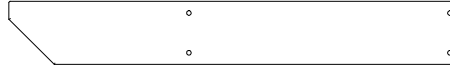

D2 JOIST END - W4L11643

(x4) 1 3/8"x5 1/4"x37 1/2" (36x134x954)



D3 SLOTTED JOIST - W4L11637

(x8) 1 3/8"x5 1/4"x114" (36x134x2896)



D4 JOIST - W4L18489

(x2) 1 3/8"x5 1/4"x90" (36x134x2286)



D5 JOIST - W4L11638

(x2) 1 3/8"x5 1/4"x90" (36x134x2286)



D6 JOIST END - W4L11633

(x8) 1 3/8"x5 1/4"x15" (36x134x381)

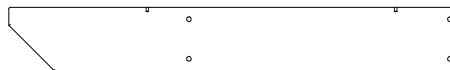

D7 JOIST END - W4L11634

(x4) 1 3/8"x5 1/4"x37 1/2" (36x134x954)

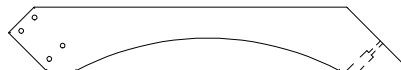

D8 LONG ANGLE BRACE - W4L18490

(x8) 1 3/8"x5 1/4"x33 1/2" (36x134x850)



D9 SHORT ANGLE BRACE - W4L18491

(x4) 1 3/8"x5 1/4"x26 5/8" (36x134x675)

Owner's Manual - Parts Identification

Wood Components (Not to Scale)



D11 JOIST - W4L11646

(x2) 1 3/8"x5 1/4"x92 7/8" (36x134x2360)

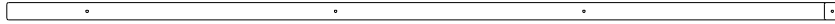

P1 PURLIN - W4L11639

(x12) 1 3/8"x1 3/8"x69 5/8" (36x36x1767)

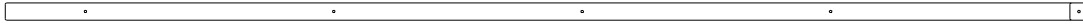

P2 PURLIN - W4L11640

(x12) 1 3/8"x1 3/8"x90 1/4" (36x36x2291)

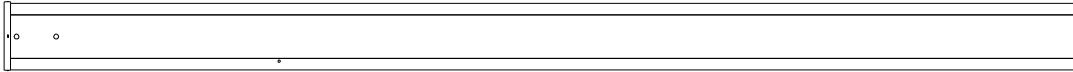

WP2 PERGOLA POST - W2A03771

(x2) 5 1/2"x5 1/2"x89 1/2" (140x140x2273)



WP1 PERGOLA POST - W2A03772

(x2) 5 1/2"x5 1/2"x89 1/2" (140x140x2273)

Owner's Manual - Parts Identification

Hardware Components

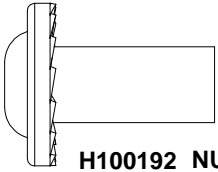

**H100192 NUT BARREL WH
BLK**
(x40) 5/16x7/8

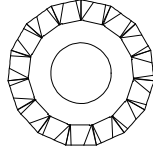

**H100198 WASHER LOCK
EXT BLK**
(x80) 8x19

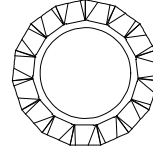

**H100199 WASHER LOCK
EXT BLK**
(x64) 12x19

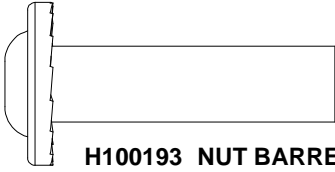

**H100193 NUT BARREL WH
BLK**
(x24) 5/16x1-1/2

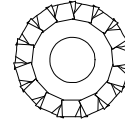

**H100405 WASHER LOCK
EXT BLK**
(x12) 6x15

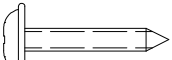

H100392 SCREW PWH BLK
(x2) 8x3/4

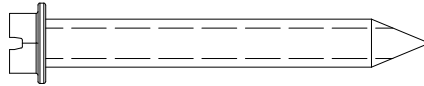

**H100120 SCREW
CONCRETE
ANCHOR**
(x16) 1/4x2



H100200 SCREW PFH BLK
(x16) 8x1 1/2

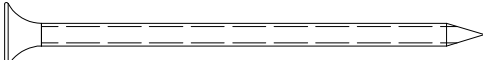

H100201 SCREW PFH BLK
(x96) 8x2-1/2

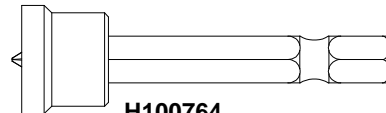

H100764 SCREW SETTER
(x1)

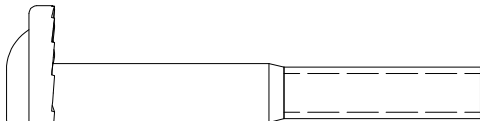

H100205 BOLT WH BLK
(x40) 5/16x2-1/4

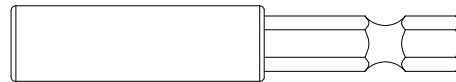

H101100 MAGNETIC DRIVER
(x1)

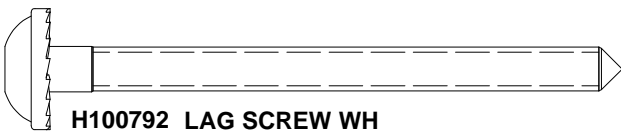

**H100792 LAG SCREW WH
BLK**
(x12) 1/4x3

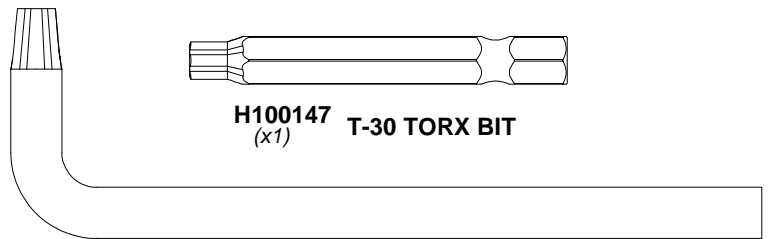

H100147 T-30 TORX BIT
(x1)

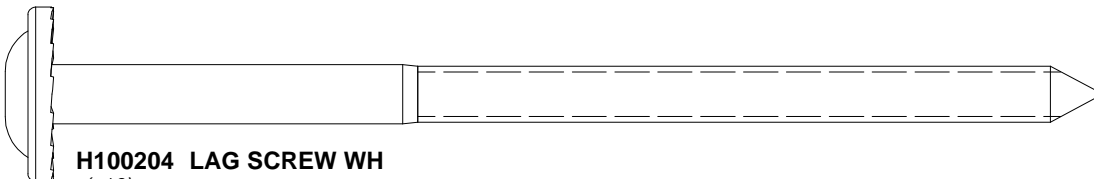

**H100204 LAG SCREW WH
BLK**
(x16) 5/16x5 1/2

H100114 T-30 TORX WRENCH
(x1)

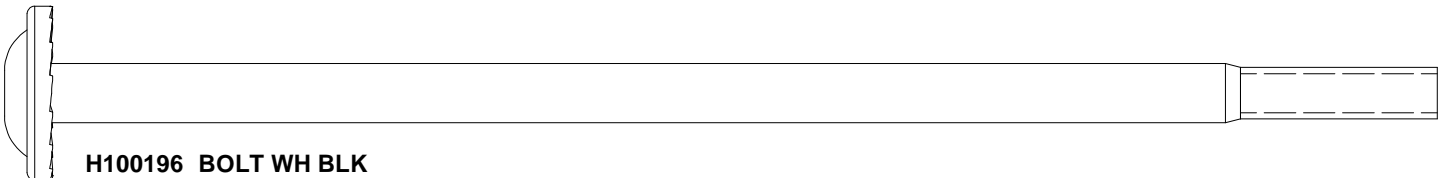

H100196 BOLT WH BLK
(x24) 5/16x7-1/4

Owner's Manual - Parts Identification

Accessory Components (Not to Scale)

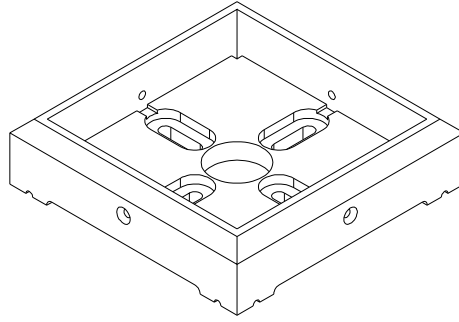

A100029
(x4) FOOT 142 SQUARE POST



A100241
(x1) BYD ID TAG (SMALL) WITHOUT AGES

PRE-ASSEMBLY STEP 1 - SORTING PARTS

It is critical for ease of assembly that you take the time to sort and organize the wood and hardware.

WOOD PARTS:

- Organize wood parts by the three-digit, alpha-numeric number stamped on each board (ex. P01).
- If there are multiple boards with the same stamped number, stack those pieces together.
- Stamps can be found on the flat surface of the boards or on the end of the boards.
- Allow yourself plenty of room - the wood pieces can take up a significant amount of space.

NOTE: CARTONS ARE NOT ORGANIZED BY BOARD NUMBER.



HARDWARE PARTS:

- We recommend that you have a separate table to organize the hardware.
- Hardware bags are printed with a seven-digit, alpha-numeric part number.
- You can organize your hardware by part number or group by hardware type (i.e. bolts, nuts, etc.).
- During assembly you only need to reference the last four digits of the number.

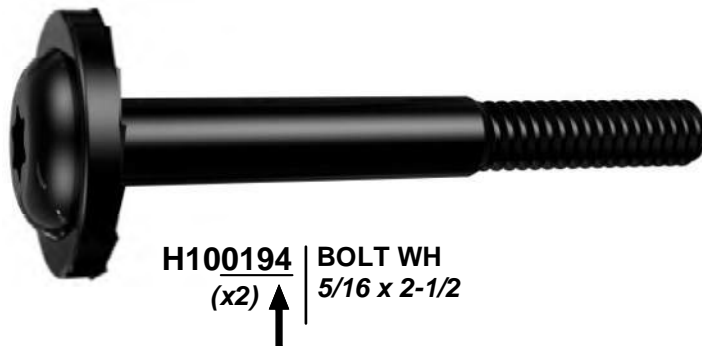

PRE-ASSEMBLY STEP 2 - TOOLS REQUIRED



Cordless Drill or
Electric Drill



Drill Attachments:
Phillips Head



1/8", 3/16", 3/8" & 7/16"
Drill Bits



Phillips Screw Driver



Open End Wrenches 1/2" & 9/16"



3/8" Drive Ratchet, 1/2" &
9/16" STD Sockets 1/2" & 9/16" Deep
Sockets



Claw Hammer



Rubber Mallet - Optional



Tape Measure

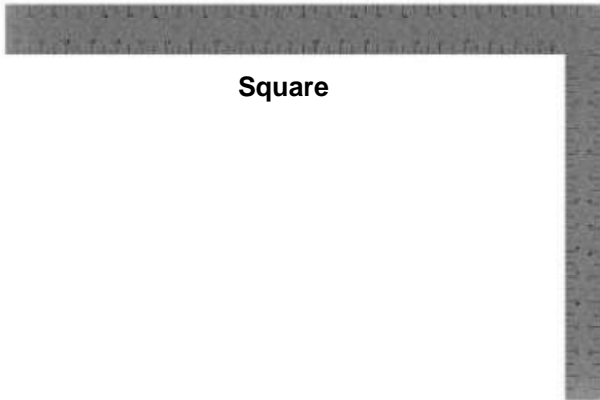

Square



Level 24"

PRE-ASSEMBLY STEP 3 - CHOOSE YOUR ASSEMBLY METHOD

There are several types of assembly instructions available to you.

1. Printed Assembly Manual included with your set
2. BILT APP - 3D interactive instructions
3. Combination of the Printed Manual and BILT APP (Note: Step numbers can differ between the two methods)

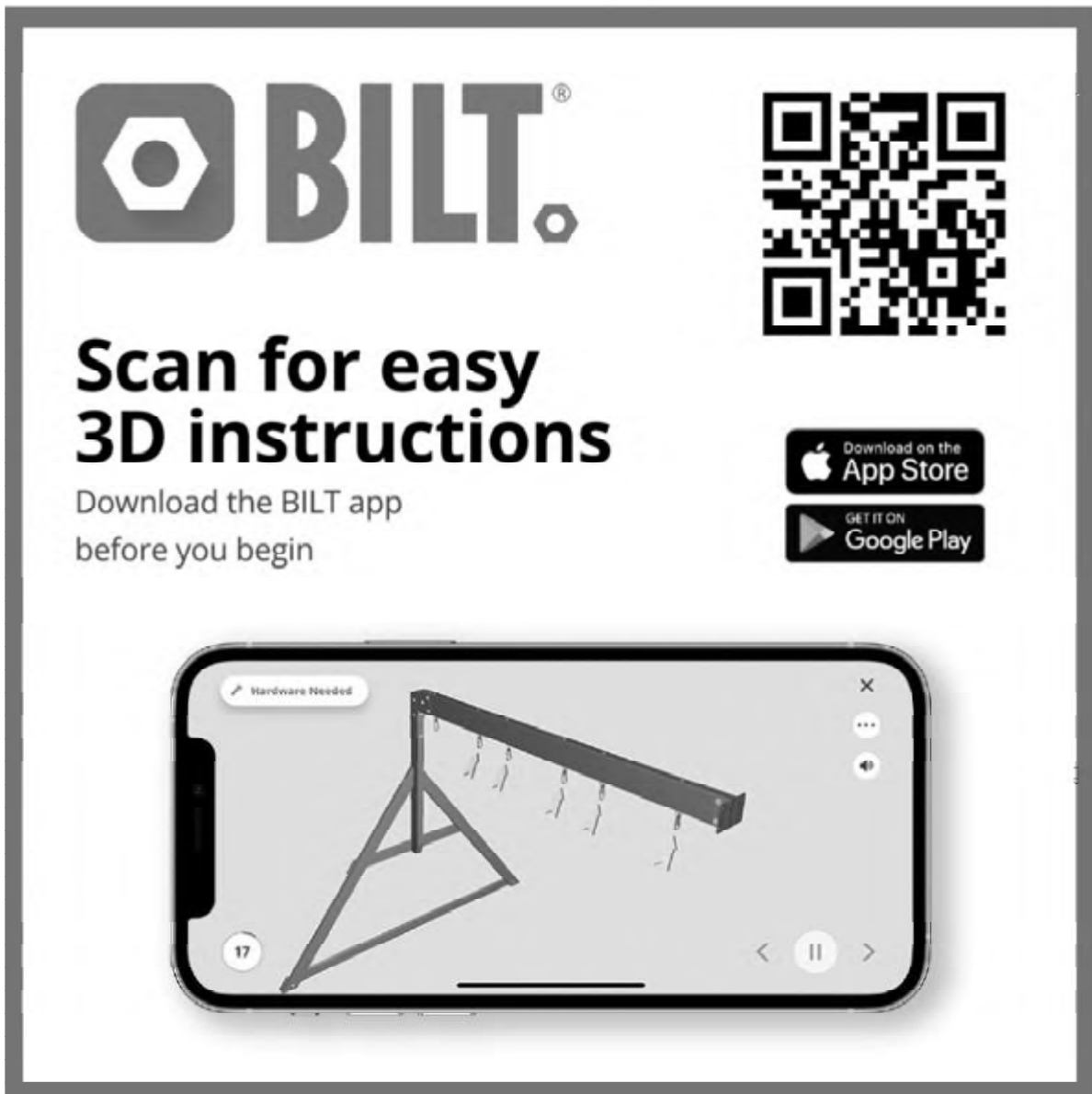

The advertisement features the BILT logo (a hexagon with a dot) and the text "BILT.®" in a large, bold font. To the right is a QR code. Below the logo, the text reads "Scan for easy 3D instructions" and "Download the BILT app before you begin". Two buttons are present: "Download on the App Store" and "GET IT ON Google Play". At the bottom, a smartphone displays a 3D assembly instruction for step 17, showing a metal frame with a horizontal bar and several hanging components. The phone screen also shows a "Hardware Needed" button, a close button (X), and navigation arrows.

STEP 1 - PERGOLA ASSEMBLY

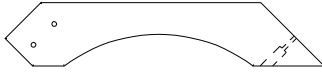

D9 SHORT ANGLE BRACE - W4L18491
 (x4) 1 3/8"x5 1/4"x26 5/8" (36x134x675)

| QTY | PART NUMBER | DESCRIPTION |
|-----|-------------|----------------------------|
| 8 | H100192 | NUT BARREL WH 5/16x7/8 BLK |
| 8 | H100198 | WASHER LOCK EXT 8x19 BLK |
| 8 | H100199 | WASHER LOCK EXT 12x19 BLK |
| 8 | H100205 | BOLT WH 5/16x2-1/4 BLK |



D4 JOIST - W4L18489
 (x2) 1 3/8"x5 1/4"x90" (36x134x2286)

REPEAT PROCESS FOR OPPOSITE SIDE.

*****HAND TIGHTEN ONLY AT THIS TIME.*****

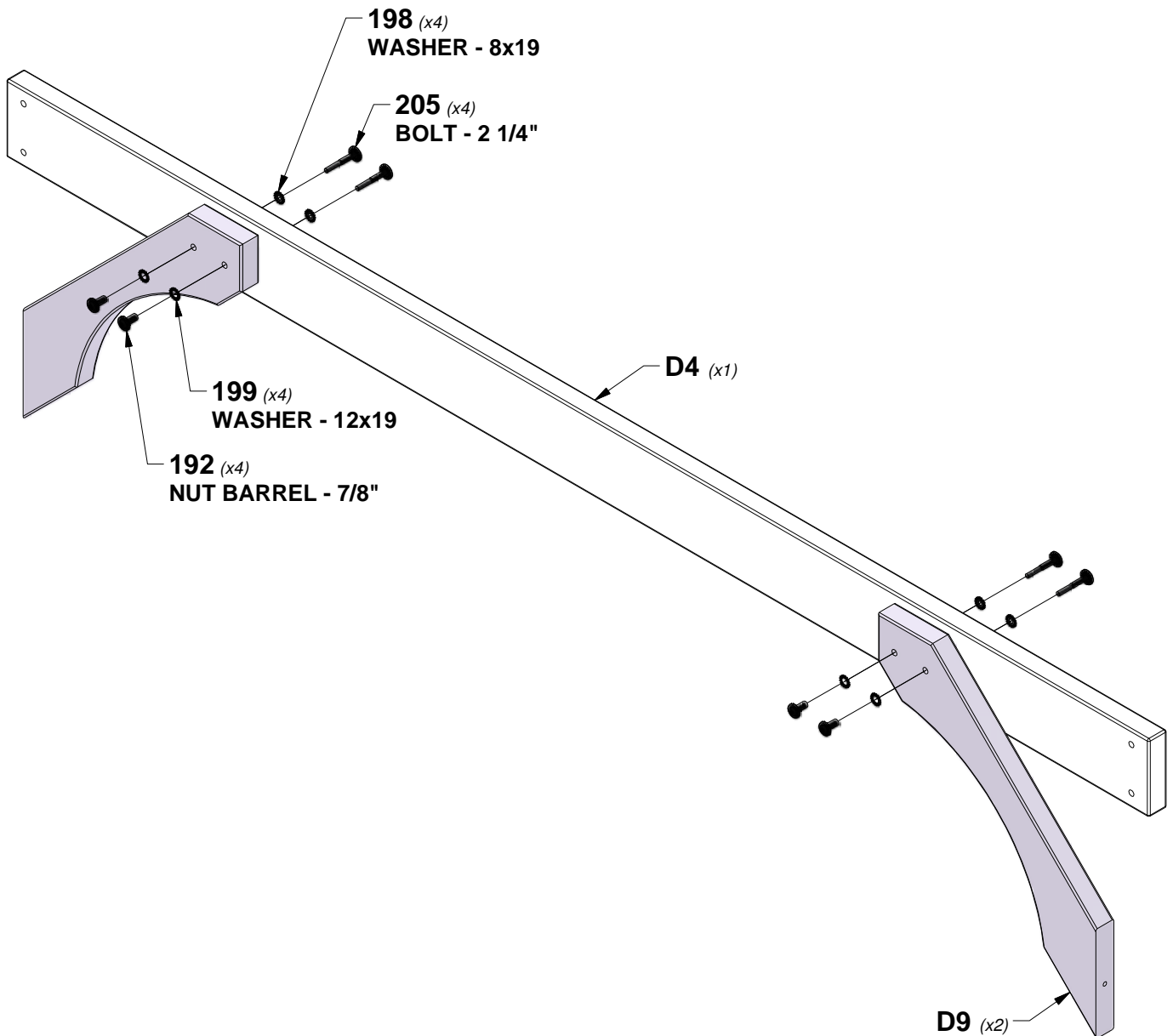

STEP 2 - PERGOLA ASSEMBLY

| QTY | PART NUMBER | DESCRIPTION |
|-----|-------------|----------------------------|
| 16 | H100192 | NUT BARREL WH 5/16x7/8 BLK |
| 16 | H100198 | WASHER LOCK EXT 8x19 BLK |
| 16 | H100199 | WASHER LOCK EXT 12x19 BLK |
| 16 | H100205 | BOLT WH 5/16x2-1/4 BLK |

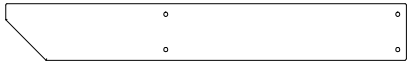

D2 JOIST END - W4L11643
(x4) 1 3/8"x5 1/4"x37 1/2" (36x134x954)



D8 LONG ANGLE BRACE - W4L18490
(x4) 1 3/8"x5 1/4"x33 1/2" (36x134x850)



D11 JOIST - W4L11646
(x2) 1 3/8"x5 1/4"x92 7/8" (36x134x2360)

REPEAT PROCESS FOR OPPOSITE SIDE.

*****HAND TIGHTEN ONLY AT THIS TIME.*****

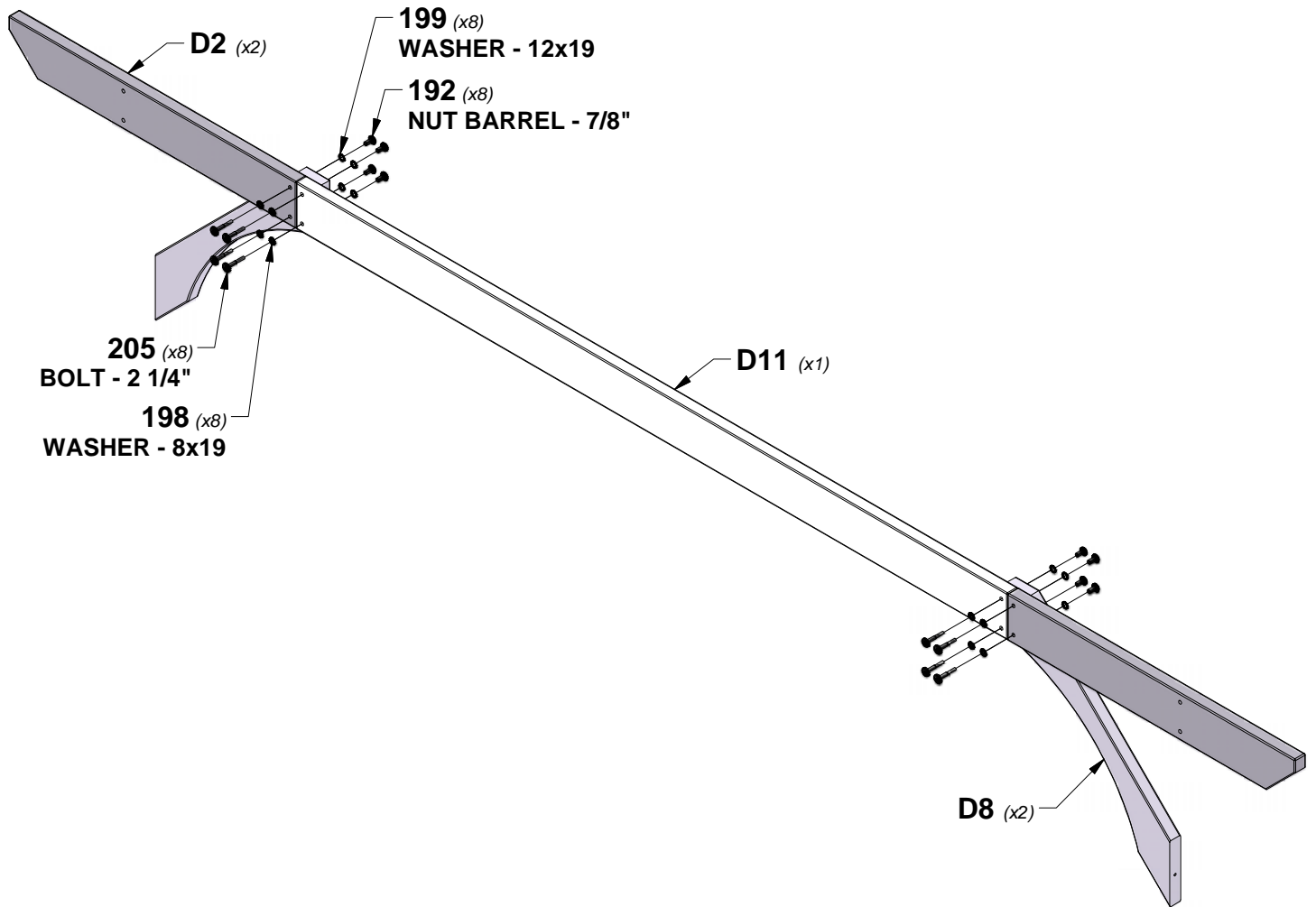

STEP 3 - PERGOLA ASSEMBLY



D7 JOIST END - W4L11634
 (x4) 1 3/8"x5 1/4"x37 1/2" (36x134x954)



D8 LONG ANGLE BRACE - W4L18490
 (x4) 1 3/8"x5 1/4"x33 1/2" (36x134x850)

| QTY | PART NUMBER | DESCRIPTION |
|-----|-------------|----------------------------|
| 16 | H100192 | NUT BARREL WH 5/16x7/8 BLK |
| 16 | H100198 | WASHER LOCK EXT 8x19 BLK |
| 16 | H100199 | WASHER LOCK EXT 12x19 BLK |
| 16 | H100205 | BOLT WH 5/16x2-1/4 BLK |



D1 JOIST - W4L11635
 (x2) 1 3/8"x5 1/4"x92 7/8" (36x134x2360)

REPEAT PROCESS FOR OPPOSITE SIDE.

*****HAND TIGHTEN ONLY AT THIS TIME.*****

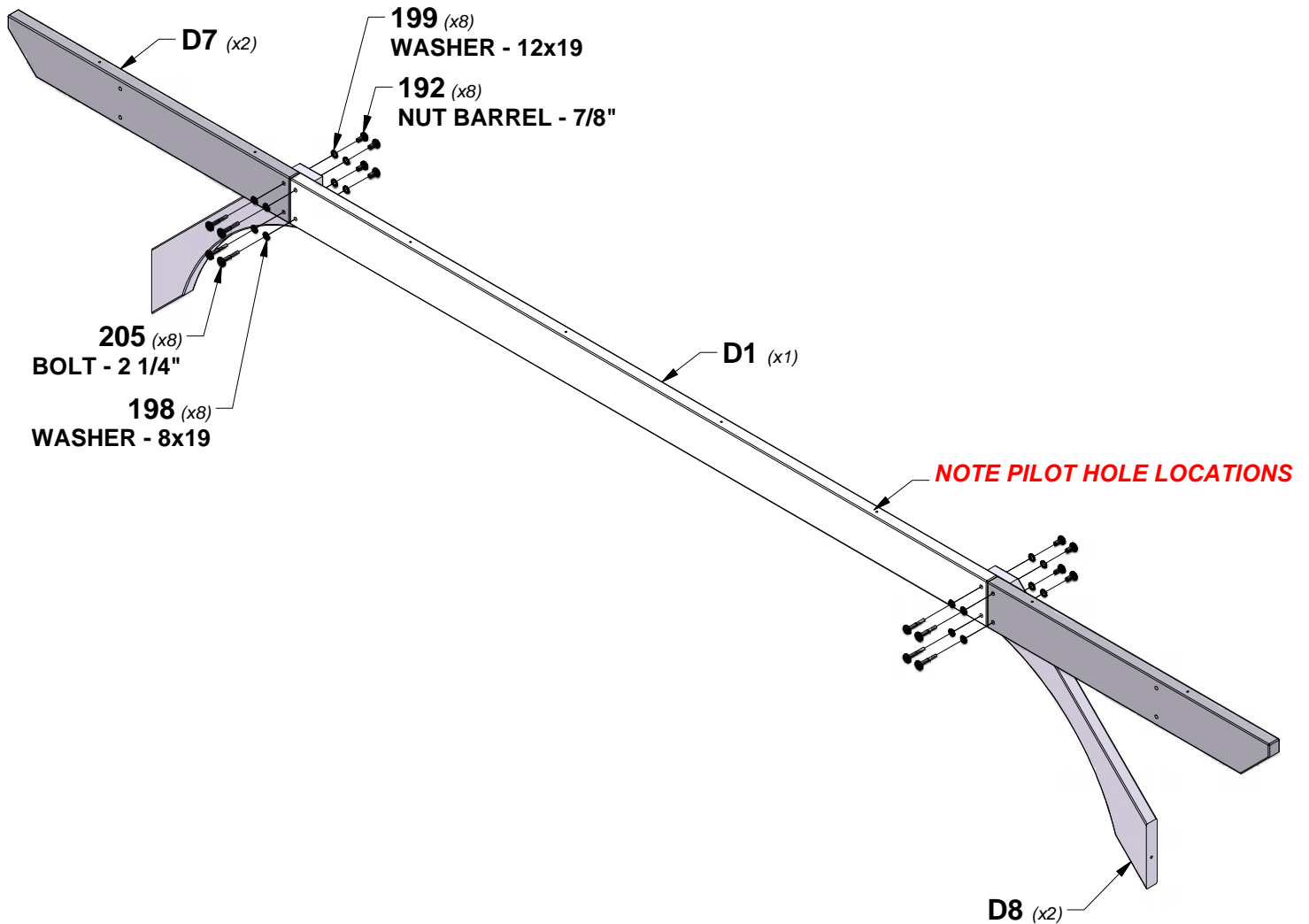

STEP 4 - PERGOLA ASSEMBLY



D5 JOIST - W4L11638
(x2) 1 3/8"x5 1/4"x90" (36x134x2286)

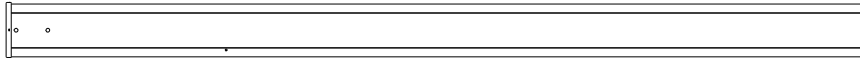

WP2 PERGOLA POST - W2A03771
(x2) 5 1/2"x5 1/2"x89 1/2" (140x140x2273)



WP1 PERGOLA POST - W2A03772
(x2) 5 1/2"x5 1/2"x89 1/2" (140x140x2273)

| QTY | PART NUMBER | DESCRIPTION |
|-----|-------------|------------------------------|
| 8 | H100193 | NUT BARREL WH 5/16x1-1/2 BLK |
| 8 | H100196 | BOLT WH 5/16x7-1/4 BLK |
| 8 | H100198 | WASHER LOCK EXT 8x19 BLK |
| 8 | H100199 | WASHER LOCK EXT 12x19 BLK |
| 4 | H100405 | WASHER LOCK EXT 6x15 BLK |
| 4 | H100792 | LAG SCREW WH 1/4x3 BLK |

REPEAT PROCESS FOR OPPOSITE SIDE.

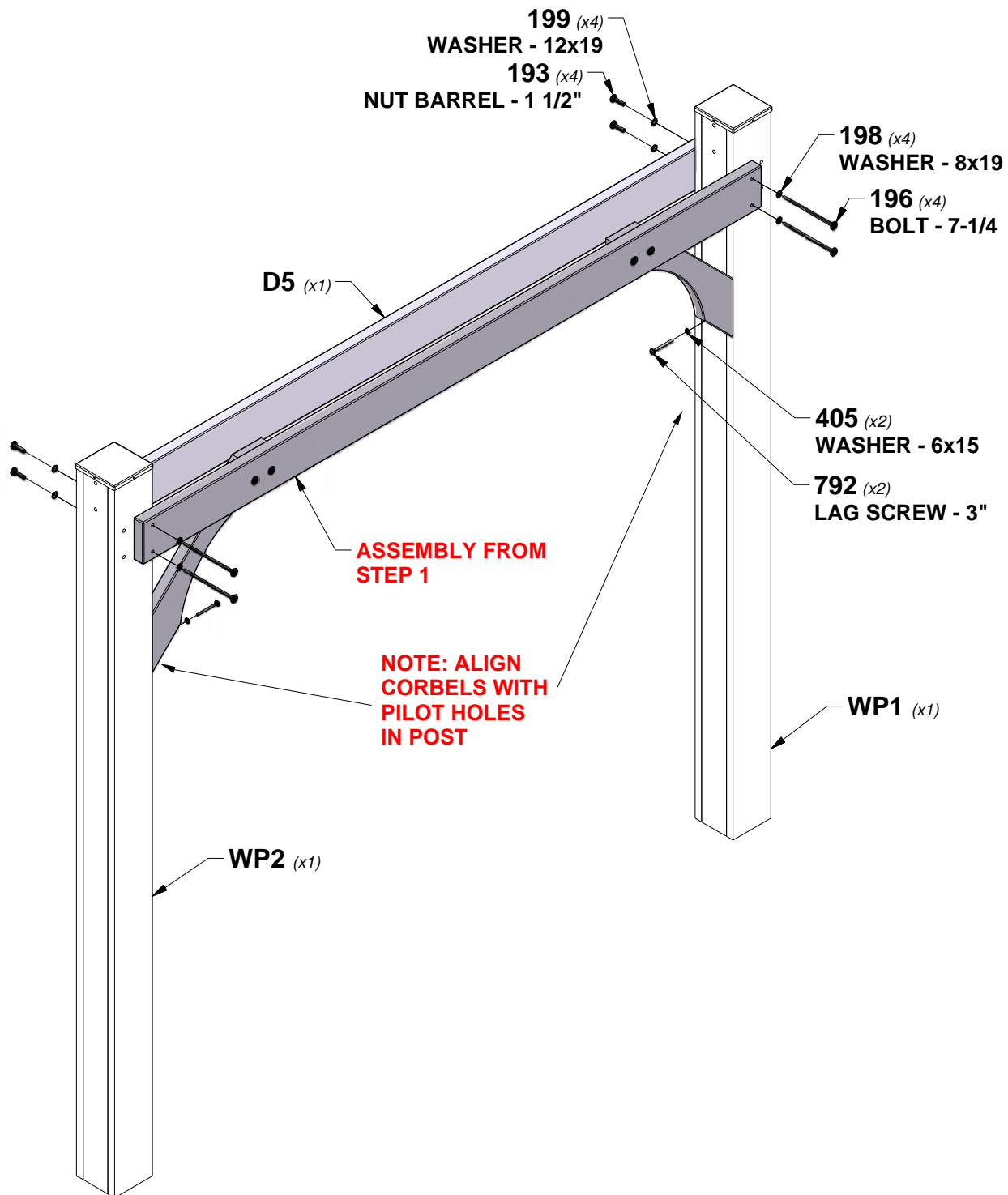

STEP 5 - PERGOLA ASSEMBLY



D6 JOIST END - W4L11633
 (x8) 1 3/8"x5 1/4"x15" (36x134x381)

| QTY | PART NUMBER | DESCRIPTION |
|-----|-------------|------------------------------|
| 8 | H100193 | NUT BARREL WH 5/16x1-1/2 BLK |
| 8 | H100196 | BOLT WH 5/16x7-1/4 BLK |
| 8 | H100198 | WASHER LOCK EXT 8x19 BLK |
| 8 | H100199 | WASHER LOCK EXT 12x19 BLK |

REPEAT PROCESS FOR OPPOSITE SIDE.

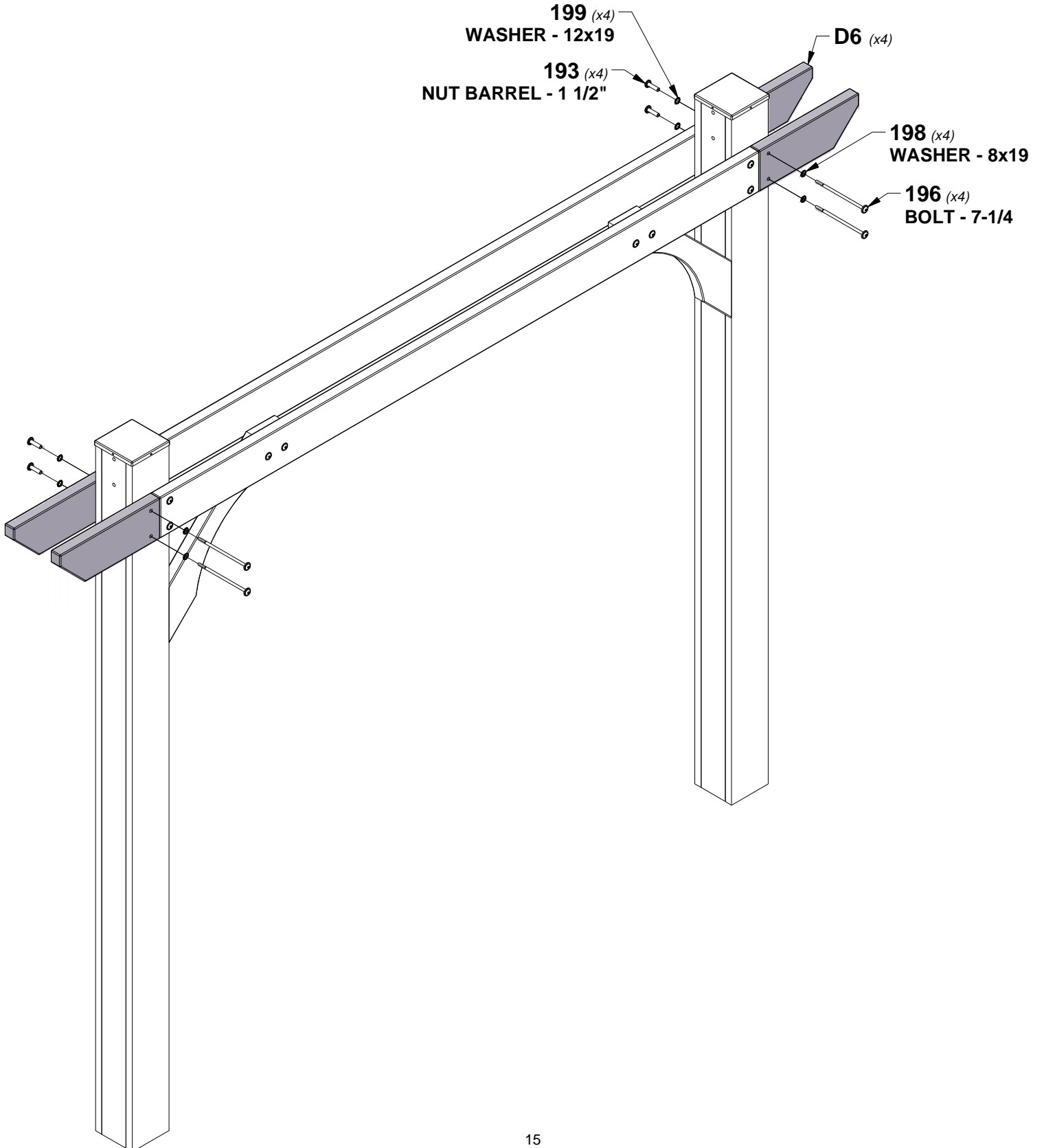

STEP 6 - PERGOLA ASSEMBLY

| QTY | PART NUMBER | DESCRIPTION |
|-----|-------------|------------------------------|
| 8 | H100193 | NUT BARREL WH 5/16x1-1/2 BLK |
| 8 | H100196 | BOLT WH 5/16x7-1/4 BLK |
| 8 | H100198 | WASHER LOCK EXT 8x19 BLK |
| 8 | H100199 | WASHER LOCK EXT 12x19 BLK |
| 8 | H100405 | WASHER LOCK EXT 6x15 BLK |
| 8 | H100792 | LAG SCREW WH 1/4x3 BLK |

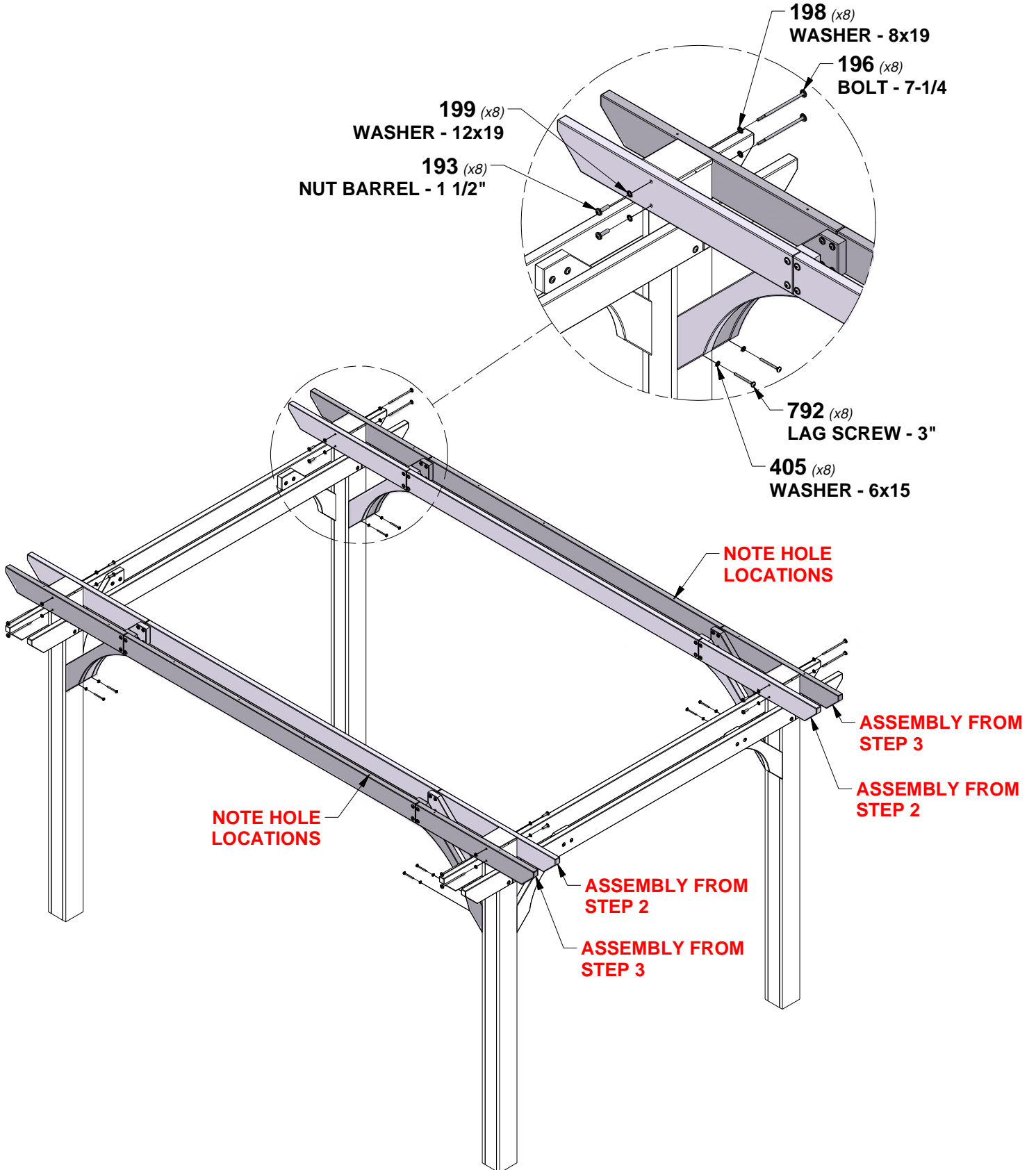

STEP 7 - PERGOLA ASSEMBLY

| QTY | PART NUMBER | DESCRIPTION |
|-----|-------------|-----------------------------|
| 16 | H100198 | WASHER LOCK EXT 8x19 BLK |
| 16 | H100204 | LAG SCREW WH 5/16x5-1/2 BLK |

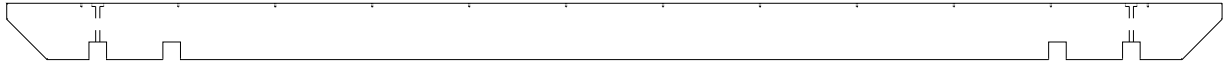

D3 SLOTTED JOIST - W4L11637
(x8) 1 3/8"x5 1/4"x114" (36x134x2896)

ALIGN JOIST OVER PILOT HOLES IN LOWER JOIST

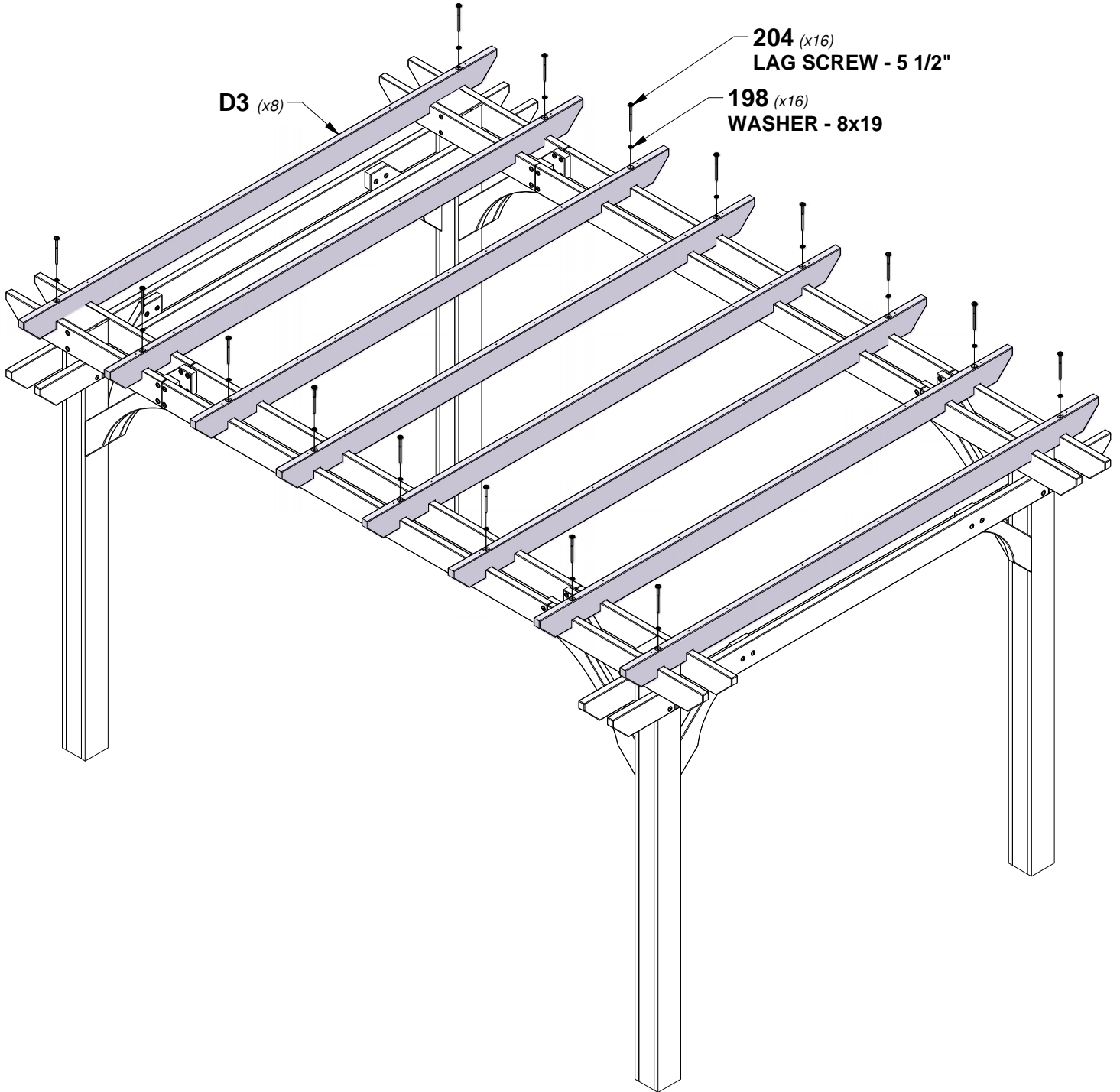

STEP 8 - PERGOLA ASSEMBLY

| QTY | PART NUMBER | DESCRIPTION |
|-----|-------------|-----------------------|
| 96 | H100201 | SCREW PFH 8x2-1/2 BLK |

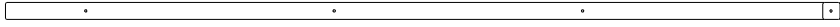

P1 PURLIN - W4L11639
(x12) 1 3/8"x1 3/8"x69 5/8" (36x36x1767)

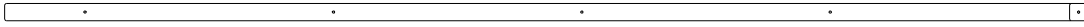

P2 PURLIN - W4L11640
(x12) 1 3/8"x1 3/8"x90 1/4" (36x36x2291)

ASSEMBLE REMAINING P1 AND P2 PURLINS ALTERNATING LOCATIONS AS SHOWN.

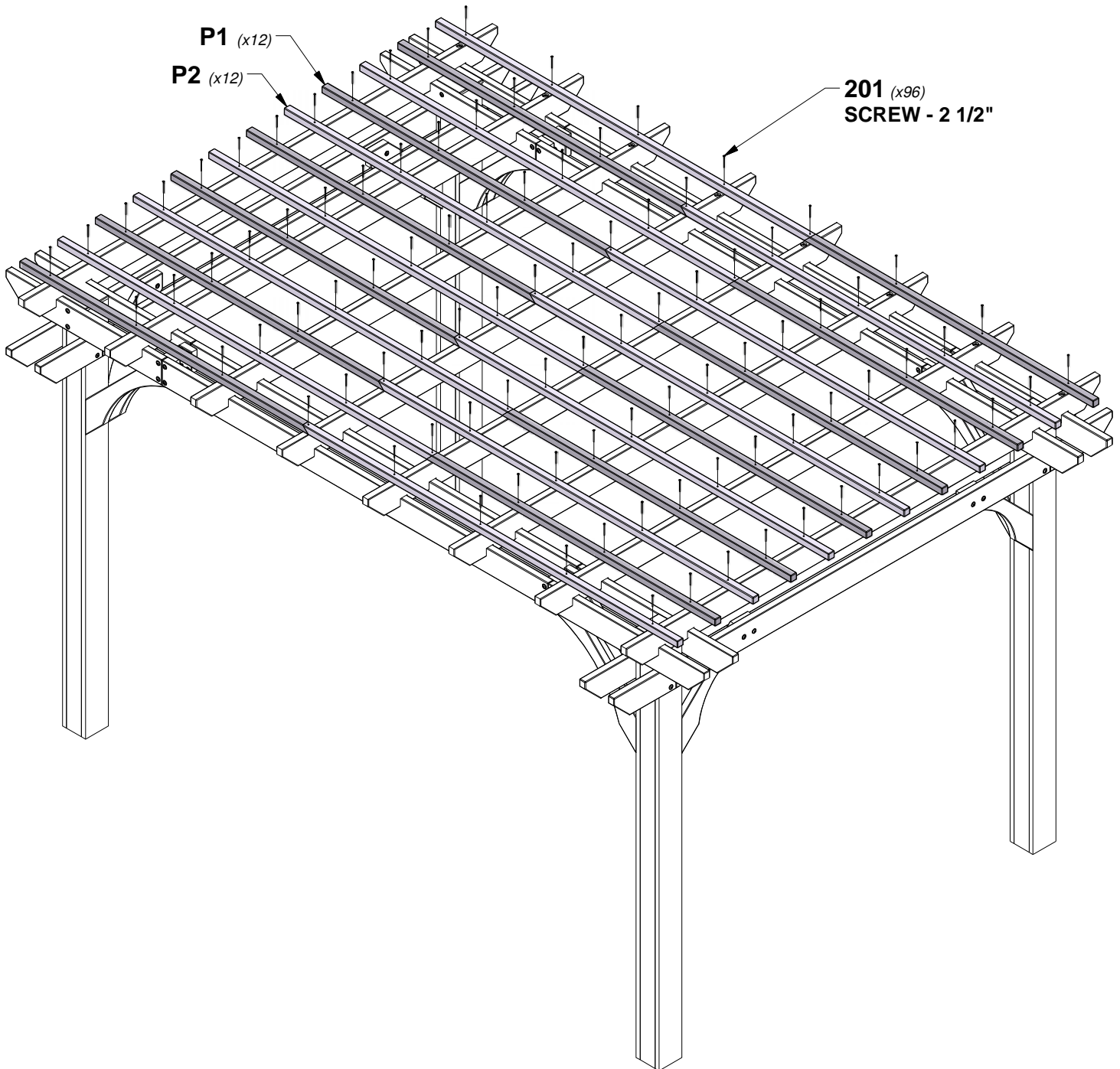

STEP 9 - PERGOLA ASSEMBLY

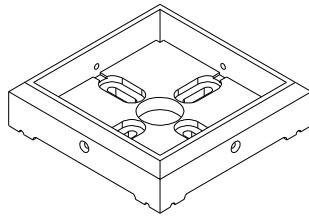

A100029
(x4) FOOT 142 SQUARE POST

DECIDE WHERE TO PLACE THE PERGOLA; GRASS, CONCRETE OR OTHER MATERIAL. PLACE THE PERGOLA EXACTLY WHERE IT WILL BE ANCHORED WHEN COMPLETED AND SLIDE A FOOT UNDER EACH POST 'WP1'.

**NOTE:
IF NOT PLACING ON CONCRETE, PROCEED TO STEP 13.**

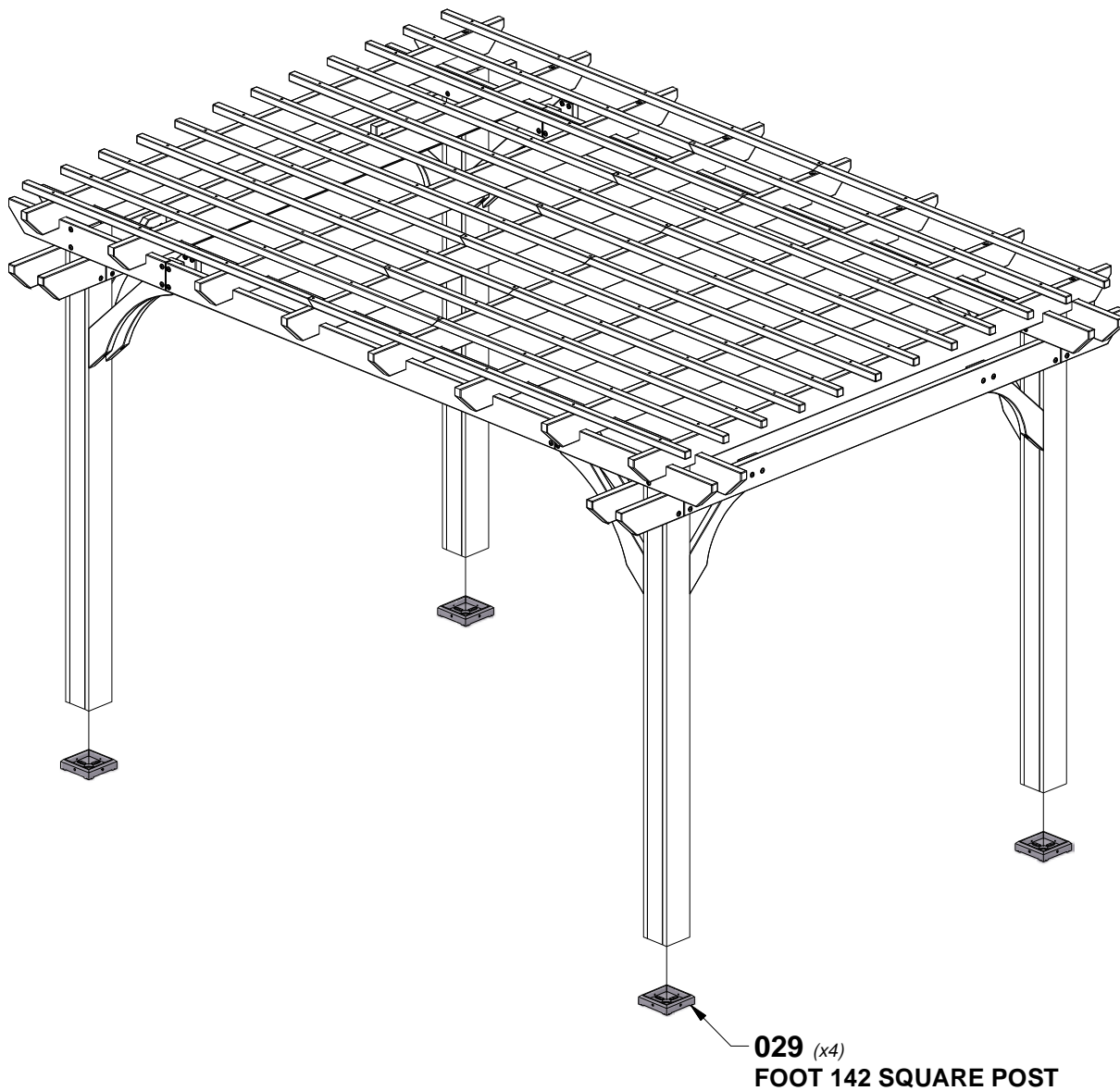

STEP 10 - PERGOLA ASSEMBLY

USE CHALK TO TRACE AROUND THE EDGES OF EACH FOOT.

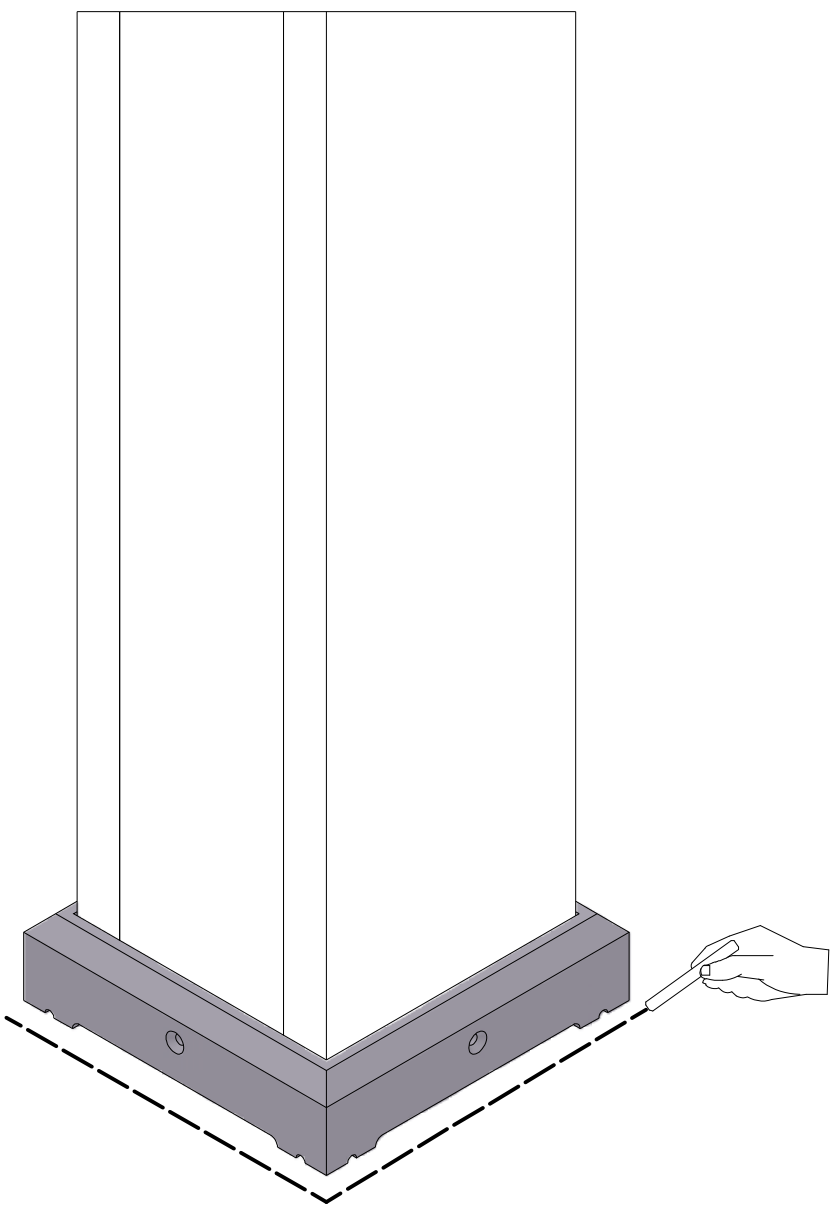

STEP 11 - PERGOLA ASSEMBLY

| QTY | PART NUMBER | DESCRIPTION |
|-----|-------------|-----------------------|
| 16 | H100120 | CONCRETE ANCHOR 1/4x2 |

MOVE THE PERGOLA ASIDE. PLACE EACH FOOT INSIDE OF THE LINES DRAWN IN STEP 14. USING A CONCRETE DRILL BIT, PILOT DRILL ATTACHMENT HOLES INTO THE CONCRETE PAD.

NEXT, USE THE 1/4"x2" CONCRETE ANCHORS TO ATTACH EACH FOOT TO THE CONCRETE SURFACE.

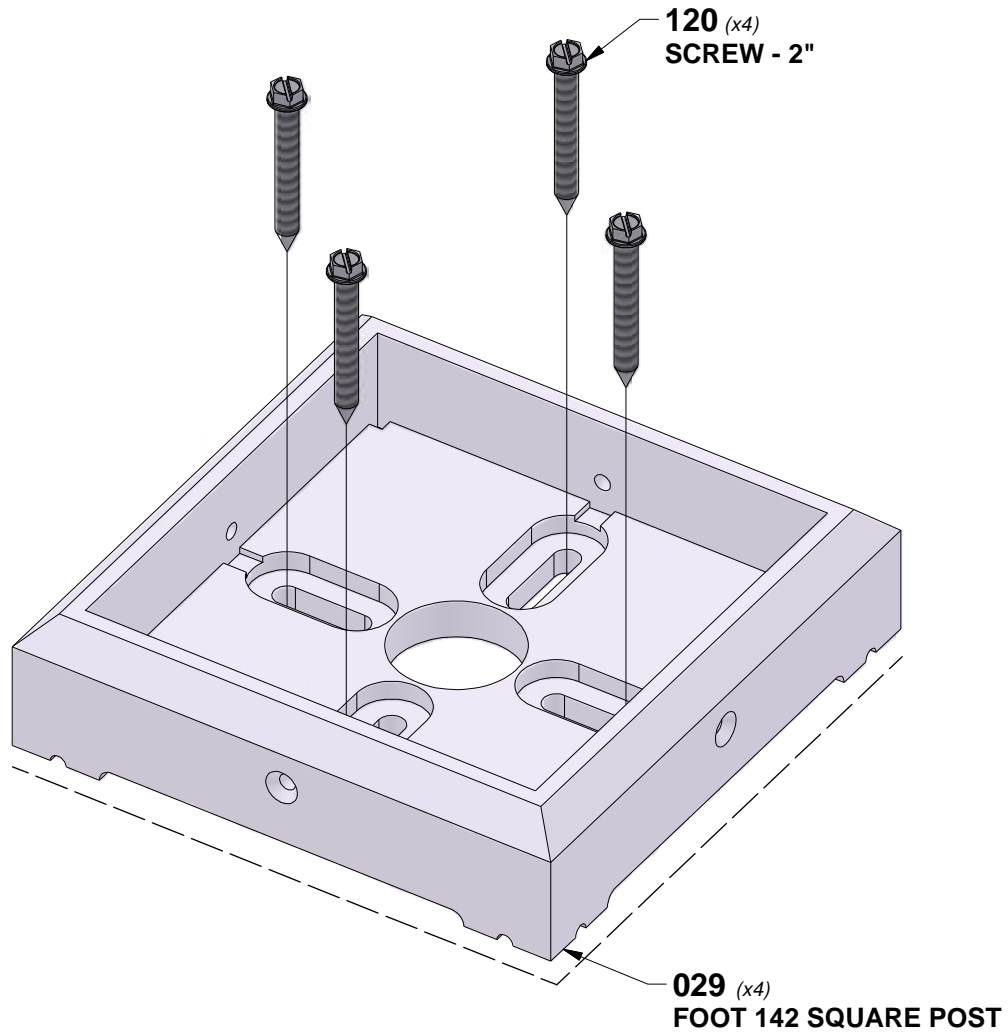

STEP 12 - PERGOLA ASSEMBLY

SET THE PERGOLA BACK IN PLACE, SETTING EACH POST 'WP1' INSIDE AN FOOT.

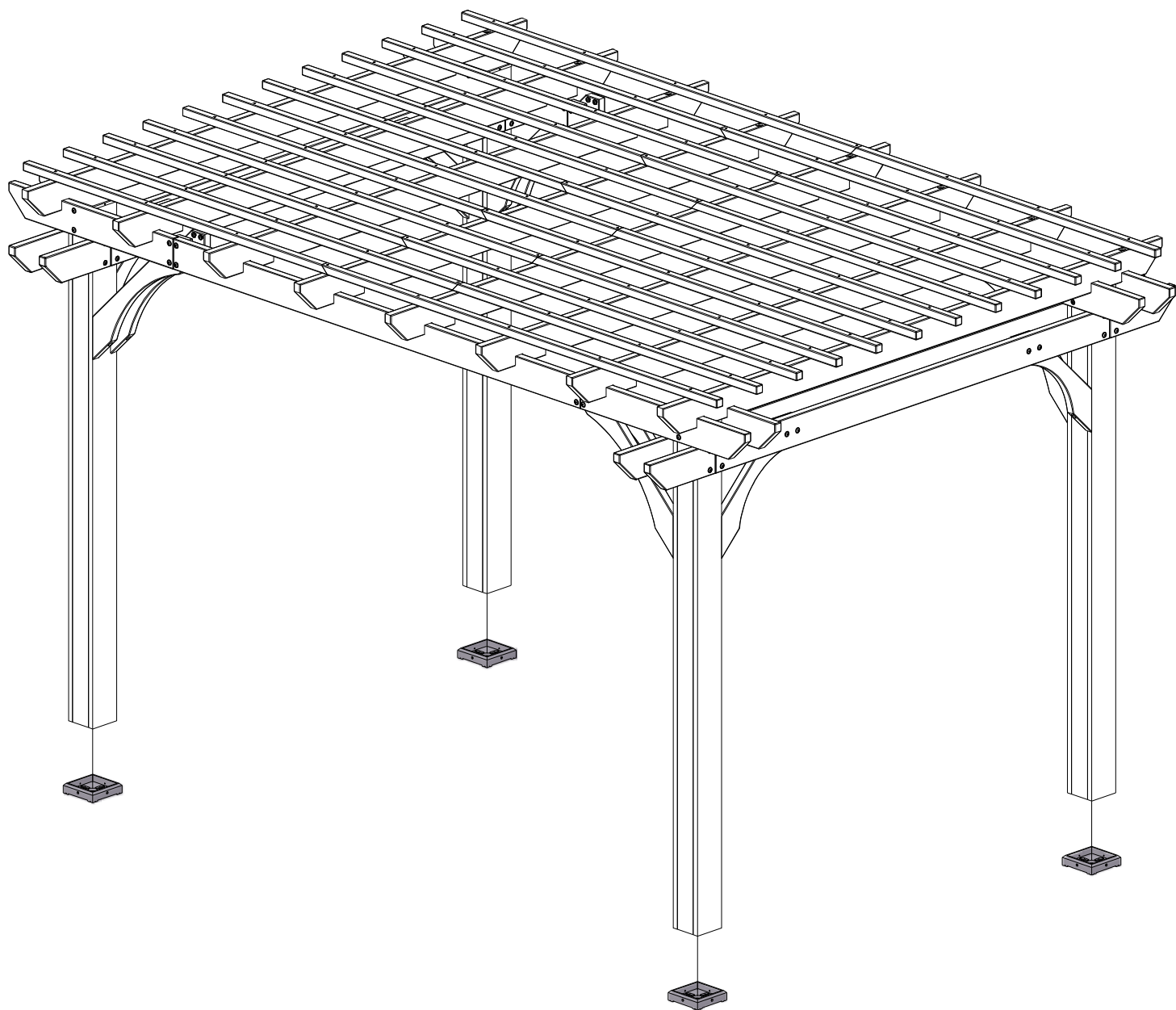

STEP 13 - PERGOLA ASSEMBLY

| QTY | PART NUMBER | DESCRIPTION |
|-----|-------------|-----------------------|
| 16 | H100200 | SCREW PFH 8x1-1/2 BLK |

ATTACH FEET TO EACH 'WP1' POST USING 1-1/2" SCREWS INTO EACH SIDE OF FOOT, AS SHOWN.

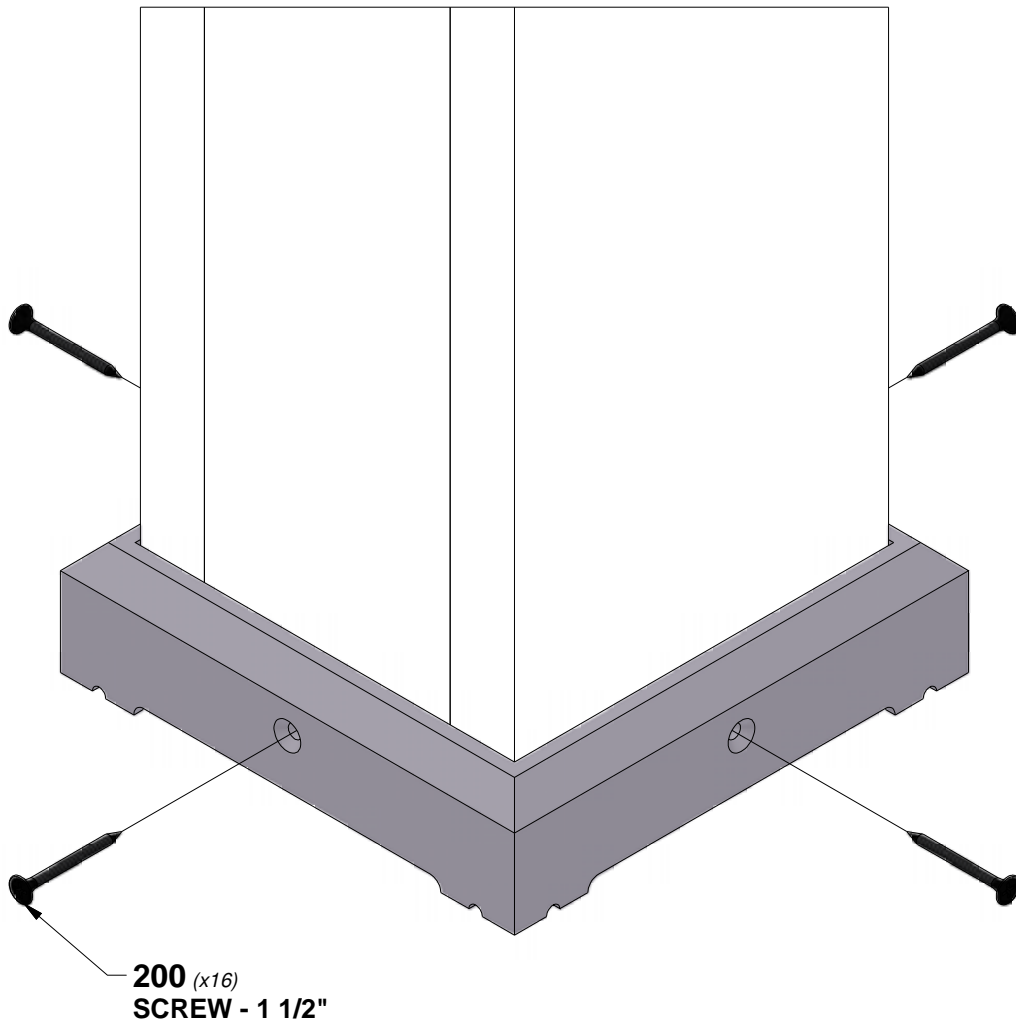

STEP 14 - PERGOLA ASSEMBLY

| QTY | PART NUMBER | DESCRIPTION |
|-----|-------------|---------------------|
| 2 | H100392 | SCREW PWH 8x3/4 BLK |



A100241 (x1) | BYD ID TAG (SMALL) WITHOUT AGES

PLACE I.D. PLACARD ON FRONT OF POST APPROXIMATELY AS SHOWN.

SQUARE POSTS AND TIGHTEN ALL HARDWARE AT THIS TIME.

