

2-Tier Printer Stand

Ok, let's get rolling

Estimated time for assembly





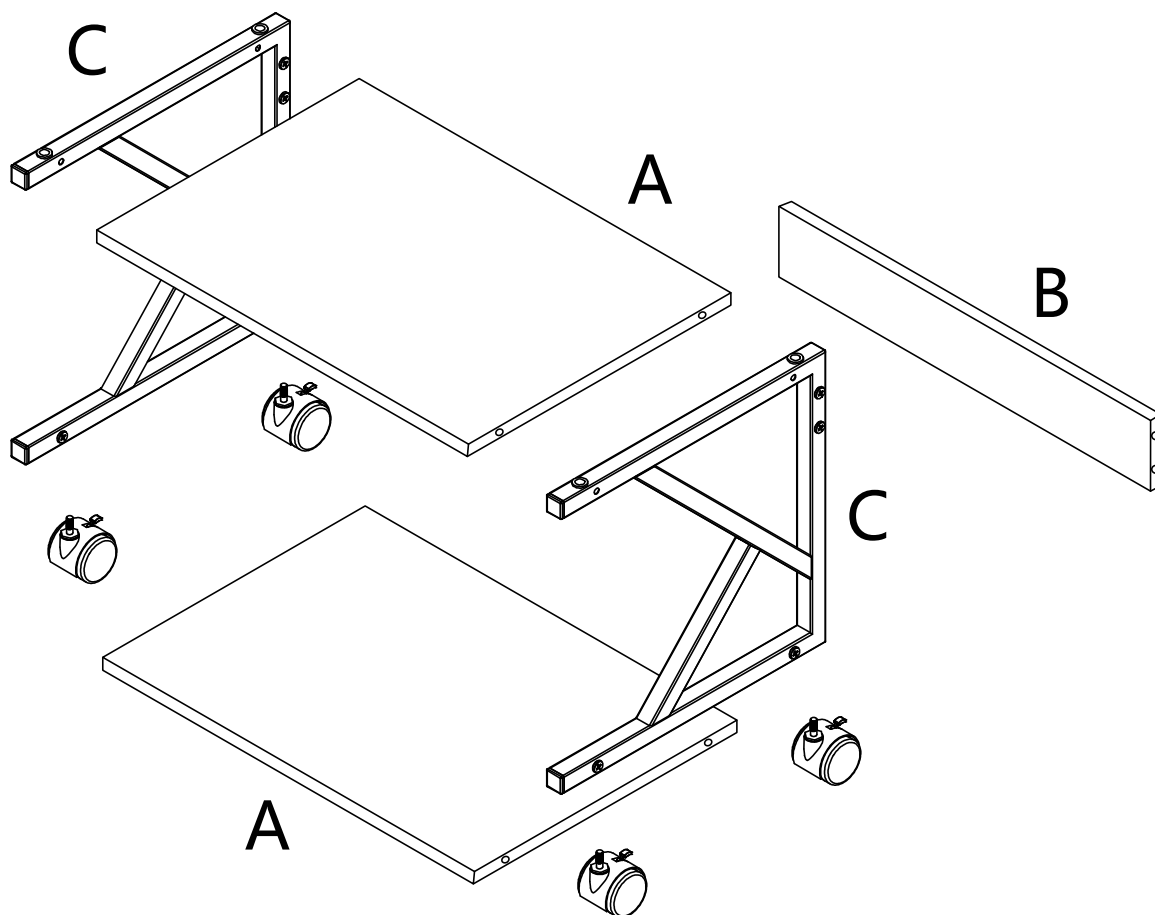

15:00

Precautions before installation

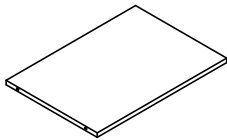
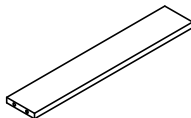
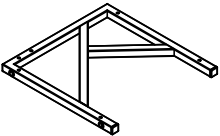
1. We try our best to make no mistakes in the instructions, but if you find any problems in our instructions, welcome to contact our online customer service feedback, thank you very much!

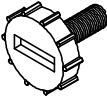

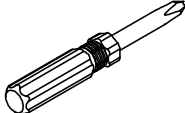
①x 2 	B x 1 	C x 2 	D x 12 	E x 4 
F x 4 	G x 1 			

1

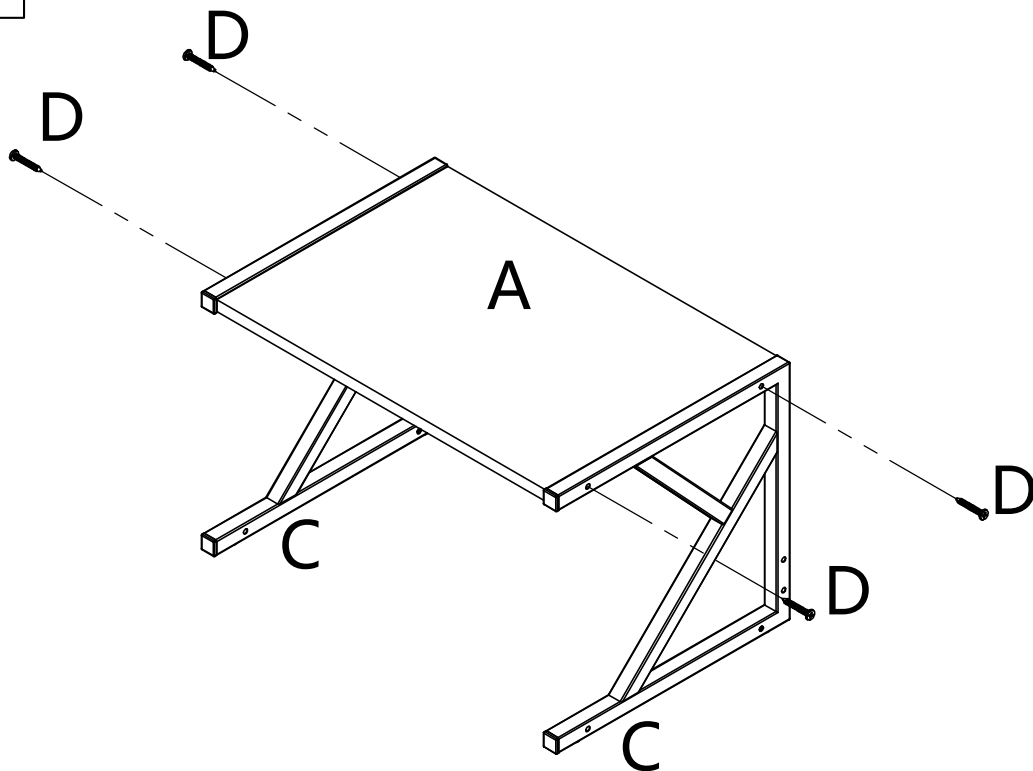
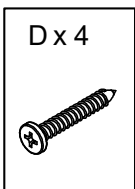

2

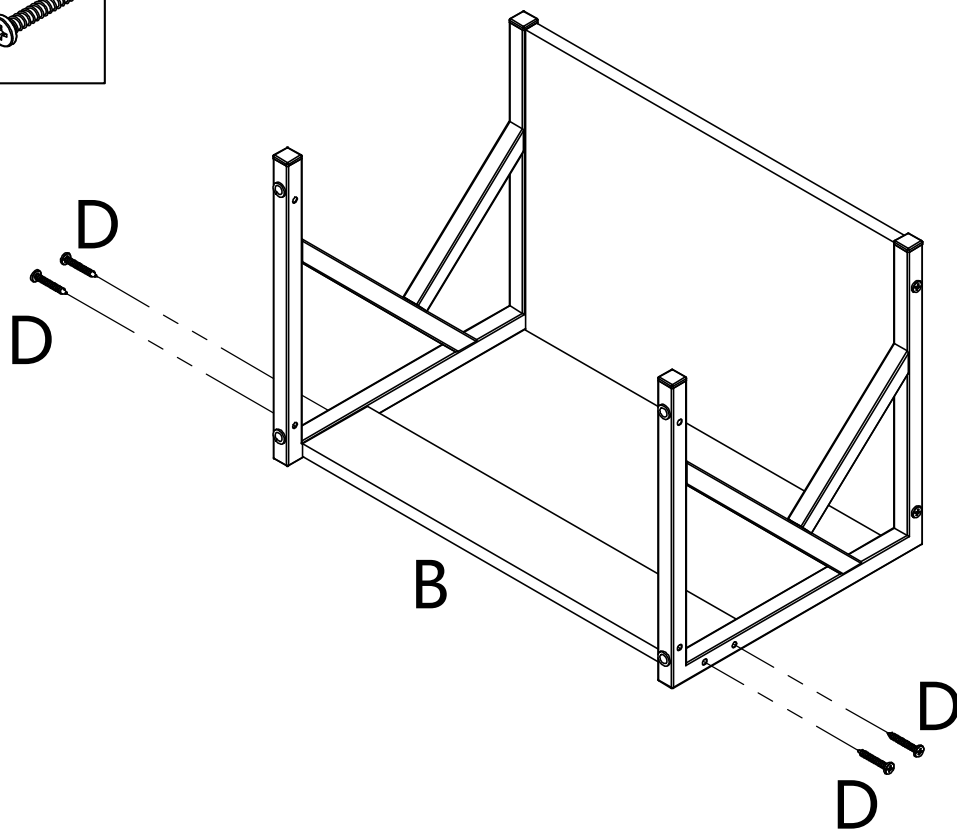
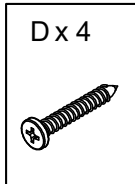

3

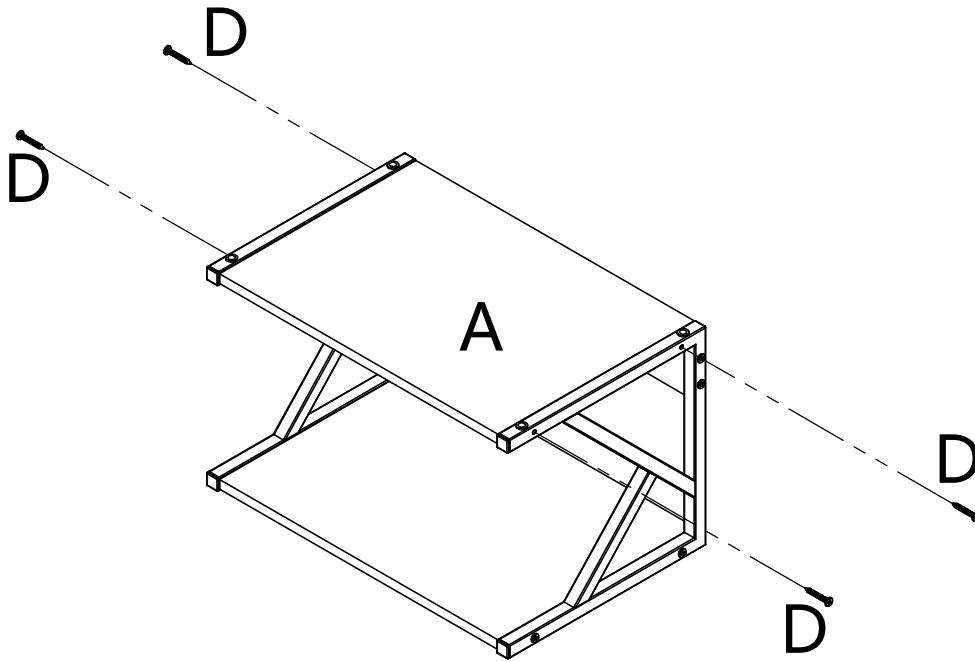
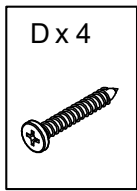

4

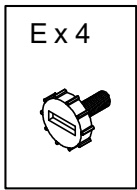

OR

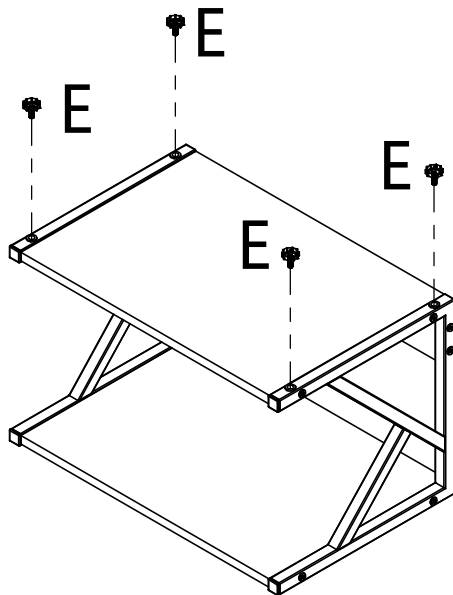
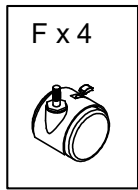

OR

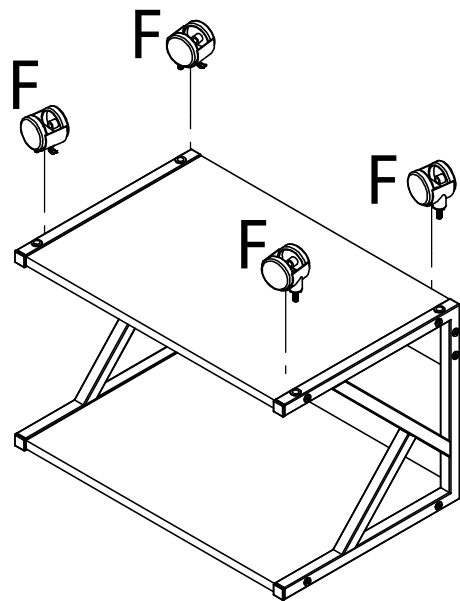

5

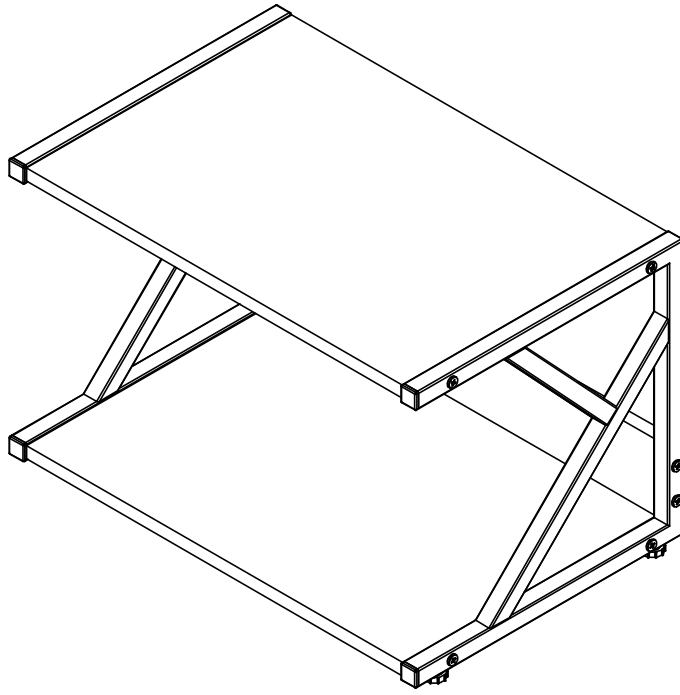

OR

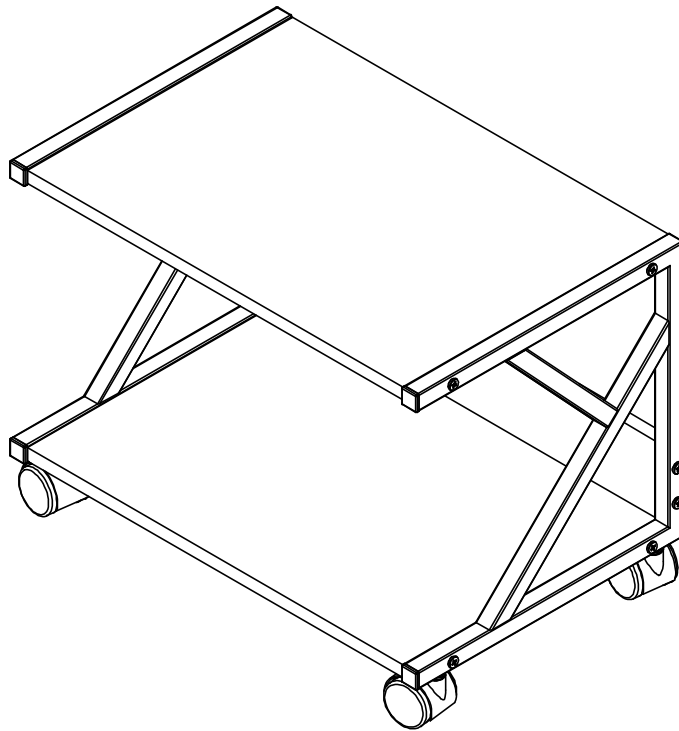

5

Comfort starts and ends at our furniture

Thank you for your support

 If you have any doubt, please contact our online service

We do our best to ensure your furniture arrives without any damages.

If you have received a faulty or incorrect part,

we will send the replacement part(s) for free immediately.

ENJOY YOUR PURCHASE!

We strive to make you happy and we'd love your feedback. Please share it with us!