

# Faringdon Traditional Angled Thermostatic Radiator Valve



Available Finishes	
Antique Brass	Antique Copper
Brass	Black Nickel
Chrome	Nickel
Satin Nickel	Polished Copper
Brushed Copper	White
Old English Brass	Pewter
Un-lacquered Brass	Brushed Brass
Textured Black	Light Pewter

Connection Size	
Valve to Radiator	1/2" BSPT
Valve to Pipe	15 mm Compression

Allen Key size	
To adjust Lock-Shield	8 mm
To fit Coupler to Radiator	1/2"
Allen Keys are not included	

Pressure Ratings	
Max Test Pressure	12 Bar
Max Operating Pressure	10 Bar
Max Differential Pressure	1 Bar
Pressure Drop Value (Kvs)	1.6
Kvs value is the metric measure for the flow of a fully opened valve. It is defined as: The volume flow in cubic metres per hour of water at a temperature of between 5° and 40° Celsius with a pressure drop across the valve of 1 bar.	

Flow Ratings	
Normal Flow Rate	0.20m <sup>3</sup> /h
Max Flow Rate	0.30m <sup>3</sup> /h

Temperature Ratings	
Max Test Temperature	120°C
Max Operating Temperature	110°C
Temperature Adjustment Range	7 - 30 °C

**Disclaimer**  
 All dimensions are approximate and for roughing in only.  
 We reserve the right to alter dimensions without notice.  
 We recommend no work be carried out until the goods arrive.  
 We can take no responsibility for errors in information supplied.

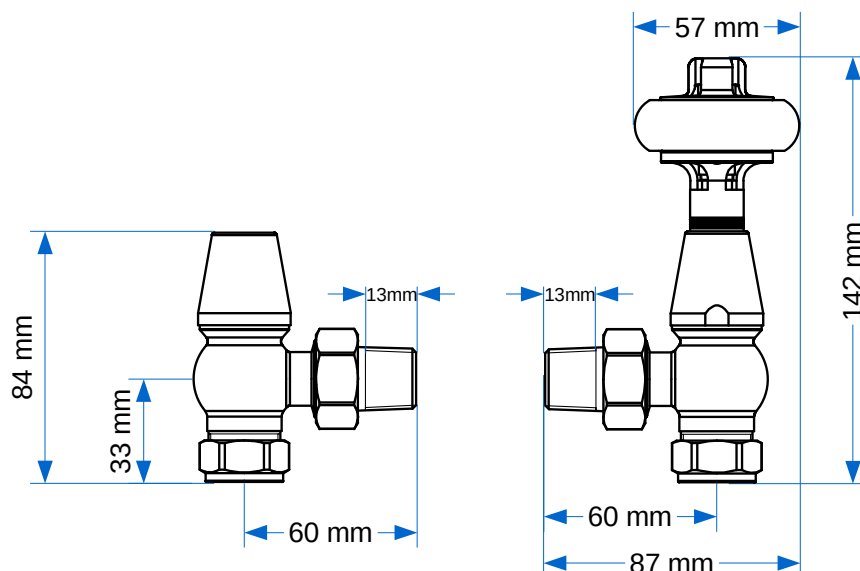

# Traditional Thermostatic Radiator Valve

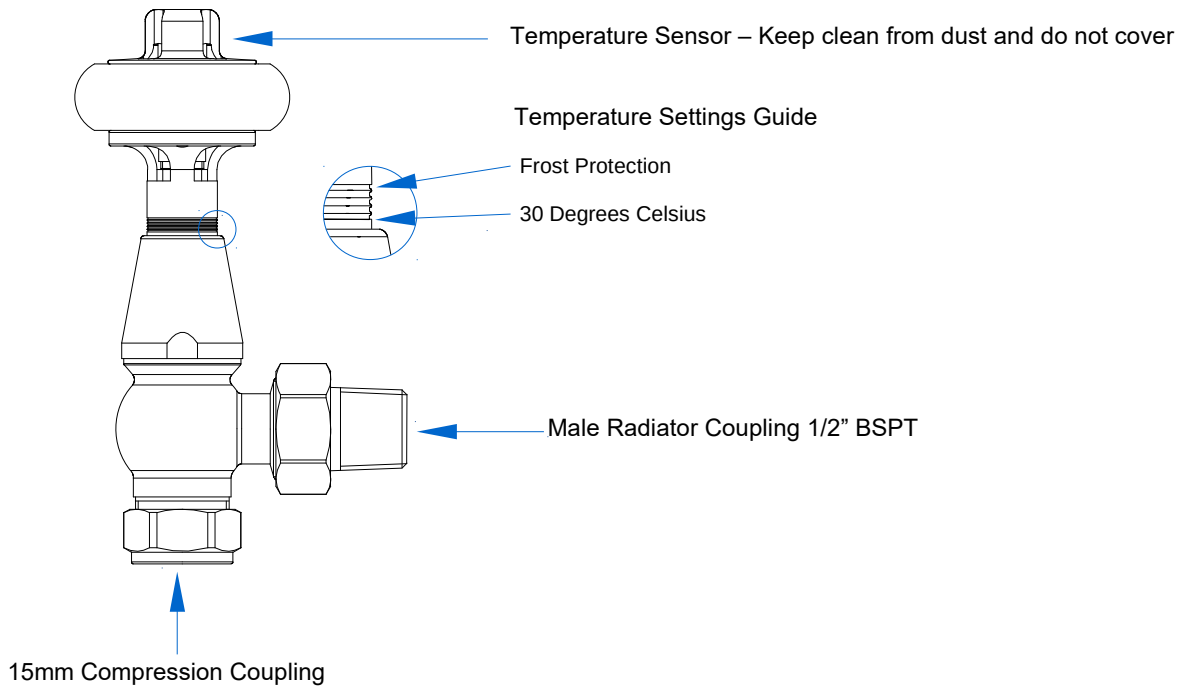

## Thermostatic Temperature Control

When the wheel head is wound clockwise to the closed position the valve will still operate if the room temperature falls below 7 degrees C, providing frost protection.

When fully open the thermostatic control operates to around 30 degrees C. The small grooves on the shaft can be used as a temperature guide. The more grooves showing, the higher the room temperature.

As with any valve, if fully opened (anti-clockwise) always turn the wheel head back one ¼ turn, to prevent sticking as room & valve temperatures alter.

Note: Never over tighten in either direction.

## Installation

Your radiator valves should only be installed by a competent and suitably qualified installer. Your warranty may be void if installation is not carried out by a suitably qualified heating engineer.

All plumbing joints should be sealed using appropriate tools, methods and materials. Never over tighten any joint or coupling.

Ensure care is taken to protect the decorative finish on the valves during installation. We would recommend applying protection (for example, at least two layers of paper between the faces of the nuts and any spanner) to ensure the surfaces are not marked.

We recommend all TRV's are installed on the flow, rather than the return pipework of a radiator. When used in conjunction with a system automatic bypass valve, this thermostatic valve can be installed on either the flow or return in any orientation. System automatic bypass valves are a specific building regulation requirement for all new installations and boiler upgrades. All bi-directional TRV's from any manufacturer require the bypass valve to function correctly and thus avoid radiator hammer.

Identifying Parts  
(FAR-AG-SN shown)



Lock-Shield

Wheel Head

