

Basebox

by Green Retreats

**Building
Instruction Manual.**

WIDE POD.

DOOR TYPE | FRENCH

3.66m x 2.44m

12ft x 8ft

Welcome.

This is your Basebox building instruction manual for the Wide Pod.

Ready.

- 01. About This Building pg 04
- 02. Safety Preparations & Advice pg 05
- 03. How to Use this Instruction Manual pg 06

Get set.

- 04. Screws, Parts & Tools pg 08
 - Additional Required Tools pg 08
 - BOX 01. pg 08
 - BOX 02. pg 10
- 05. Basebox Building Parts pg 11

Build.

- 06. Installation pg 14
 - Base pg 14
 - Floor pg 15
 - Walls pg 18
 - Roof pg 40
 - Doors pg 56
 - Trims pg 76



READY.

Make sure you're prepared for the installation of your building.



01. About your Basebox Building

Name:

Wide Pod

Approx Size:

12ft x 8ft

(for accurate sizes see details below)

Door Type:

French Door

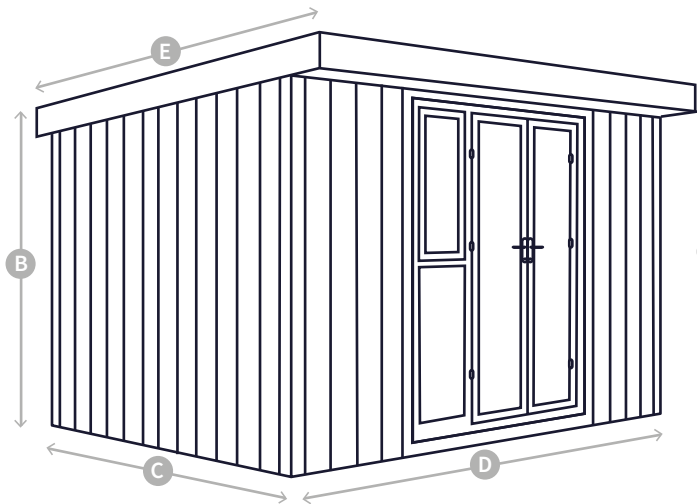

- A** External Height Front: 2500mm
- B** External Height Back: 2350mm
- C** External Depth: 2620mm
- D** External Width: 3680mm
- E** External Depth Including Overhangs: 3025mm

MM

Internal Dimensions: 3500mm (w) x 2440mm (d)

Internal Area: 8.54m²

Internal Height - Front: 2235mm

Internal Height - Back: 2085mm

External Footprint : 3680mm (w) x 2620mm (d)

External Size with Overhangs: 3680mm (w) x 3025mm (d)

External Height - Front: 2500mm

External Height - Back: 2350mm

Roof Thickness: 80mm

Overall Wall Thickness: 90mm

Wall Insulation Thickness: 70mm

Floor Thickness: 80mm

Door Height: 2070mm

Door Width: 1830mm

Glazing Thickness: 28mm

All pods have a 300mm front overhang on the roof, and a 110mm gutter at the back.



02. Safety Preparations & Advice

We strongly advise all customers to follow the below safety preparations and advice:

GENERAL ADVICE:



2 Person Build



Check for Overhead Obstacles



Consider Weather Conditions



Ensure Ladders are Supported

PPE:



Safety Footwear



Safety Gloves



FFP3 Mask



Safety Goggles

1. Prior to starting your build, check all your equipment and ensure that it is in good working condition and safe to use.
2. We strongly recommend that the construction of the building is undertaken by a minimum of two persons.
3. Check the immediate area where the building will be installed for overhead obstacles that could obstruct or cause injuries e.g. low tree branches, overhead power lines/telephone lines.
4. When lifting, be sure to use the correct technique and always lift/carry these materials with two people.
5. Wear gloves when handling materials as some edges may be sharp.
6. Ensure weather conditions are considered. Avoid installing your building in wet/icy conditions or high wind speeds. Take the relevant precautions when working in sunny or hot weather.
7. Strong sturdy footwear should be worn at all times when constructing your building.
8. Whilst cutting, drilling or using impact drivers, be sure to use the correct safety equipment i.e., safety glasses, suitable face dust mask (Recommended FFP3).
9. When using consumables, such as silicone or expanding foam, follow the COSHH data sheet for that product and pay particular attention to the minimum safety equipment requirements.
10. When working off ladders/stepladders ensure the ladders/stepladder equipment is secured or supported at all times.
11. Keep the area tidy to reduce slips trips and falls.
12. Follow the instructions at all times.



03. How to Use this Instruction Manual

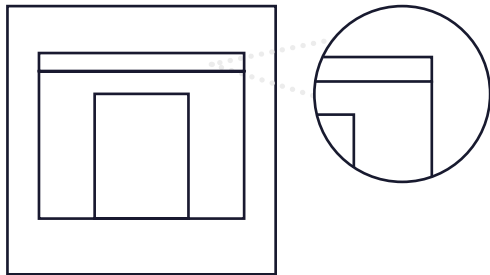

← **Take a closer look.**
Where a step has a small circle like this, it's showing you a close up.

→ **Keep track of your progress.**
Under each step number is a handy tick box to help keep track of your build.

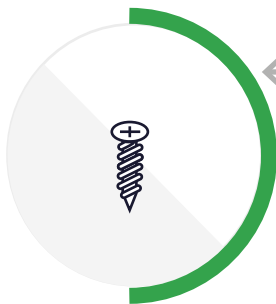
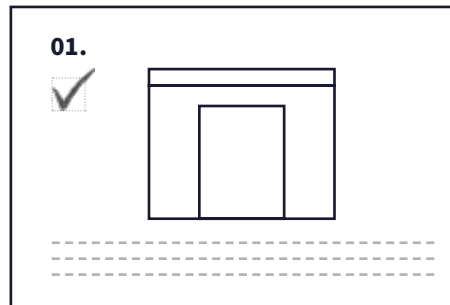

← **Colour coded screws.**
Each screw has been helpfully given a colour to help make them easier to identify. You will find this colour on your screw menu and inside the pocket for your chosen screw.

← 2x SC-1
Using PZ1

← **Screw Quantity & Type**
← **Screw Bit to Use**

→ **Easily find the correct screw location.**
Look out for these coloured pointers to help show where screws are located. These pointers will also be colour coded to the correct screw type.

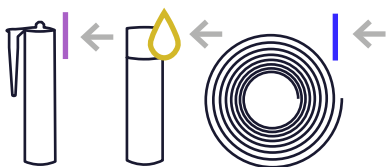

← **Find where to apply adhesives.**
Next to each adhesive icon is a coloured line. Look for this coloured line in the image for each step to find where to apply the adhesive.





GET SET.

Check that you have all of the parts, tools and equipment you need.



04. Screws, Parts & Tools

Additional Tools Required

Your Basebox is supplied with almost all of the specialist tools and equipment you'll need. These can be found in BOX 01. and BOX 02.

The only additional tools and equipment required which are not supplied are:

- 18v Drill & Impact Driver
- No.2 Hand-Held Screwdriver
- 8M Tape Measure
- 1.8m Spirit Level
- 6ft A Frame Ladder
- Platform/Hop-Up
- Silicone /Mastic Gun
- Pozi 2 Screwdriver
- Utility Knife
- Hand Saw
- String Line
- Pencil

BOX 01.

Window Packers



WP-1



WP-2



WP-3



WP-5



WP-6

Door Packers

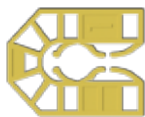

DP-1



DP-2



DP-3



DP-4



BOX 01. cont.

Screws



Drill Bits



Screw Bits

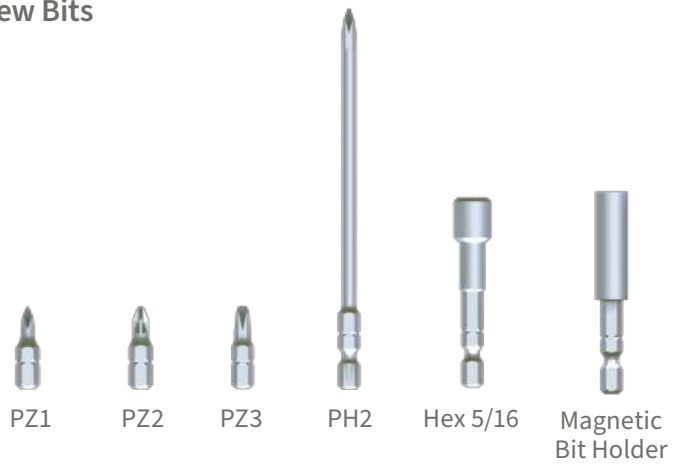

Trickle Vents

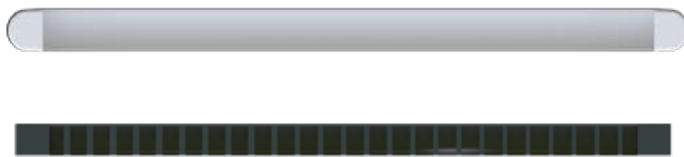

Door Adjusting Spanner



Drainage Cap



BOX 02.

Tools

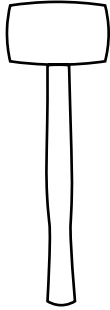

White Rubber Mallet

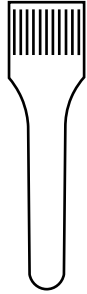

Glazing Shovel



Multi-Knife

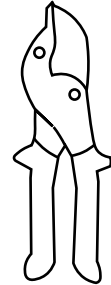

Mitre Shear

Silicone s & Adhesives

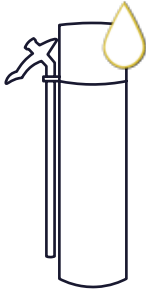

Adhesive



Silicone - Clear

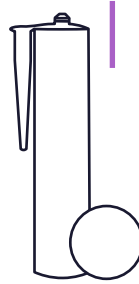

Silicone - White

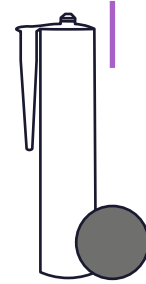

Silicone - Anthracite

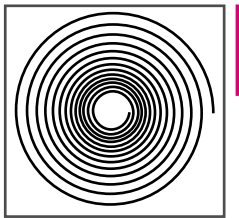

Butyl Tape

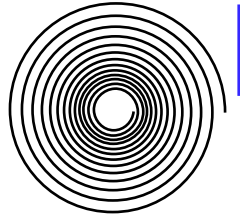

Double-Sided Tape

Guttering



T-Pipe



Downpipe End



U-Shaped Stop End



U-Shaped Gutter Bracket



Downpipe Bracket



05. Basebox Building Parts

Walls



Doors



French doors

Guttering



Foam Fillers



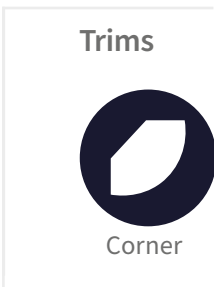
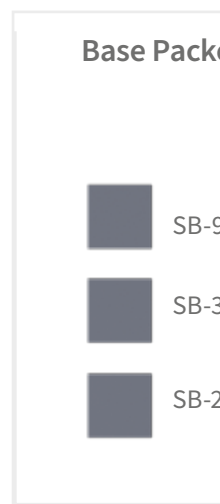
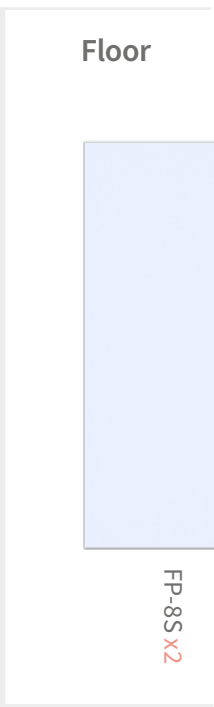

-
-
-
-
-
-
-
-
-
-
-
-
-
-
-

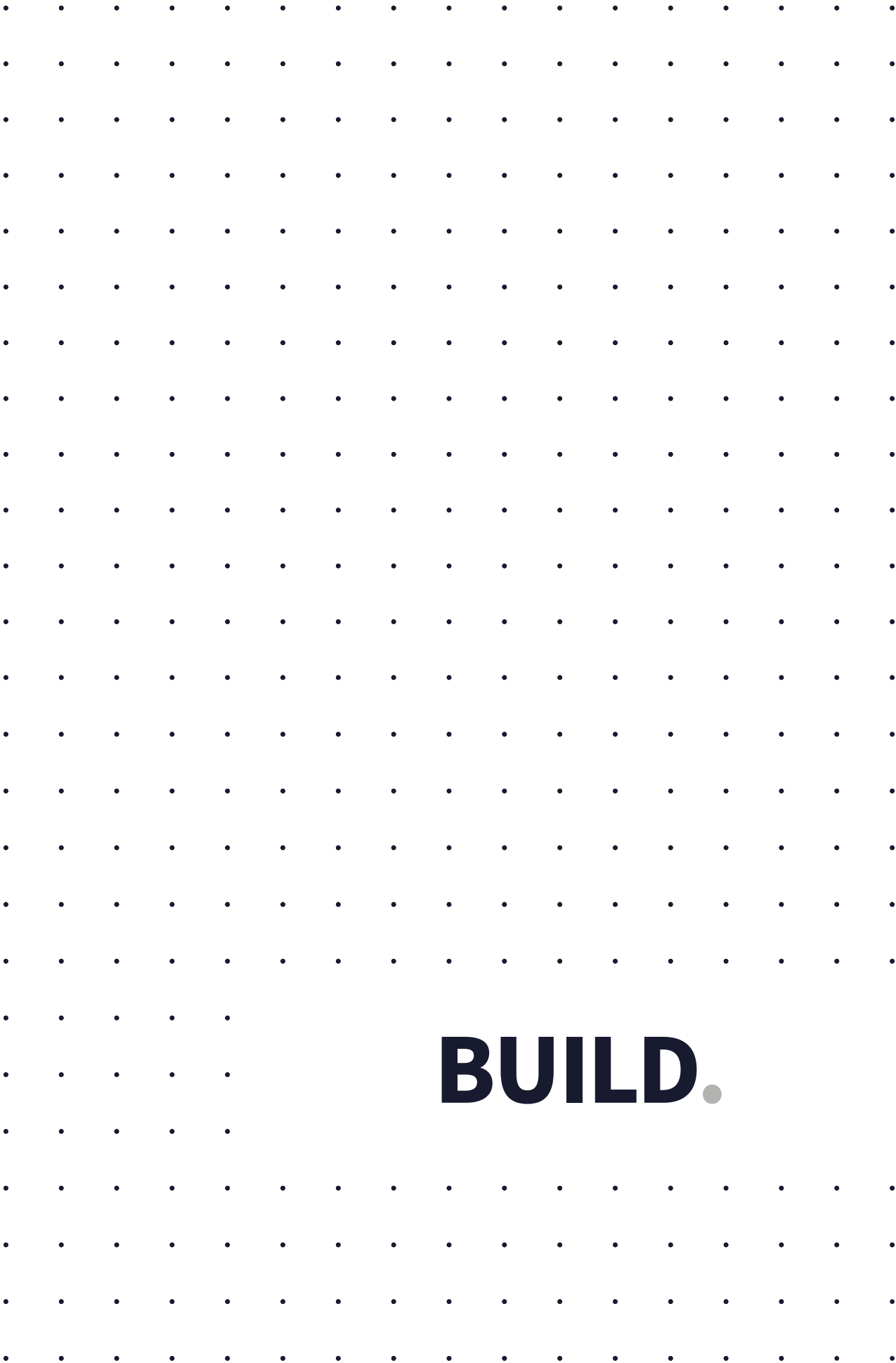

BUILD.

06. Installation



01.



TICK WHEN COMPLETE

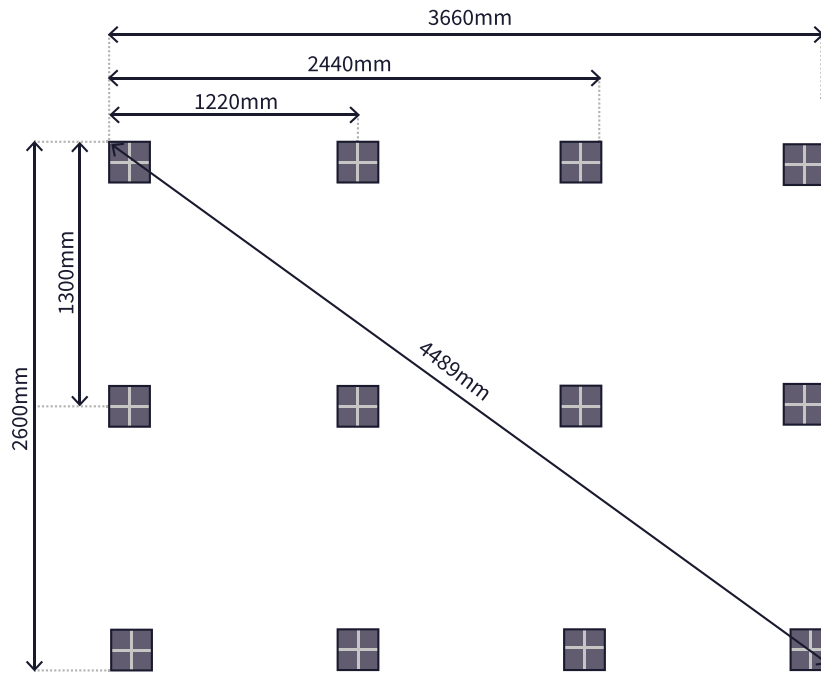

The position and site of your building should already be determined, with a level concrete base or paving slab surface laid to match the footprint of your pod building.

Lay the 9mm base packers (SB-9) onto the site using the formation shown above.

Use a spirit level to ensure all of the base packers sit at the same height once laid. As a minimum, each support location (as shown above) should have at least 1x SB-9 base packer to raise the building from contact with the floor.

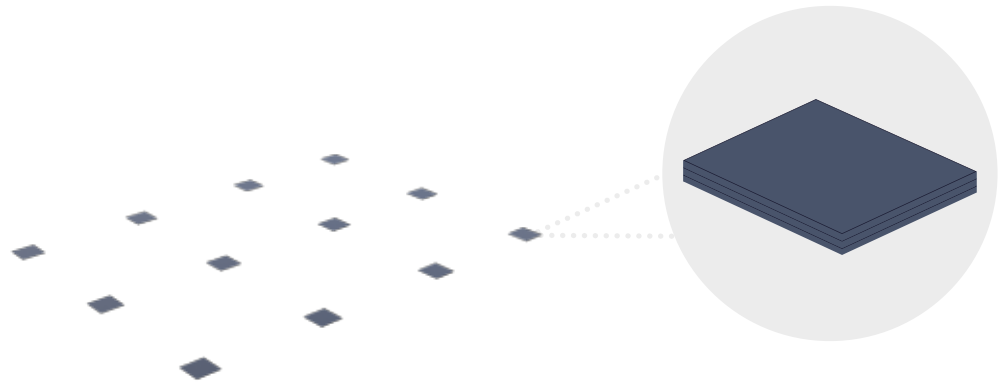

The site for your building should already be flat, however additional 3mm base packers (SB-3) and 2mm base packers (SB-2) can be used to level small tolerances in the base if required. Work from the highest natural point and then use the additional packers to bring the other support locations up to that level, using your spirit level to check the heights are flat with each other.



02

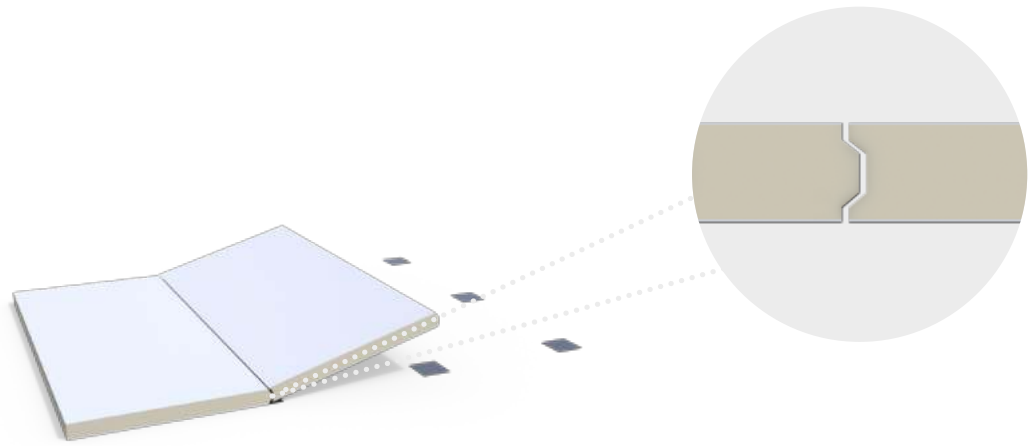

Remove the protective sticky pads from the surface of the floor panels.
Place the floor panel labelled FP-8S onto the left side of the base packers, running front to back. Then slot the floor panel labelled FP-8S into the right side of the first panel, making sure the panels join with the groove in the centre.

03

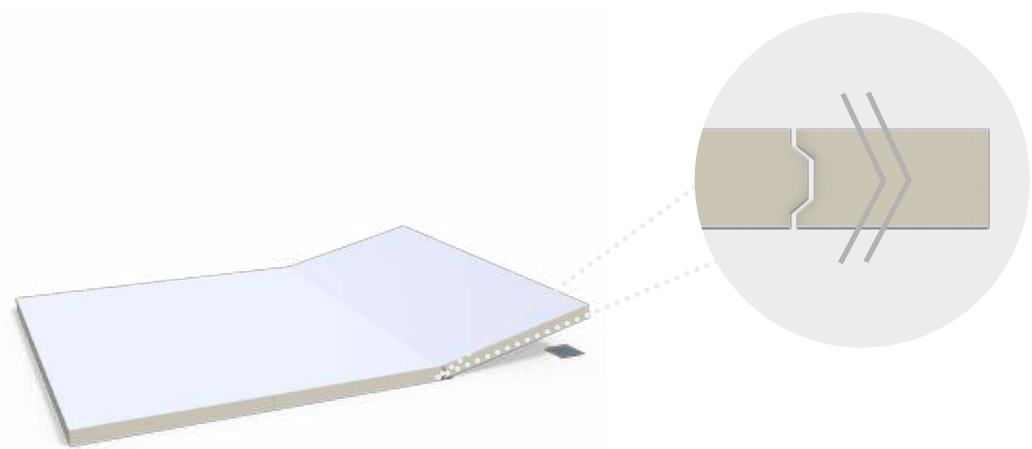

Then slot the floor panel labelled FP-8F into the right side of the first panel, making sure the panels join with the groove in the centre. This finishing floor panel has a square edge to the outside.



04

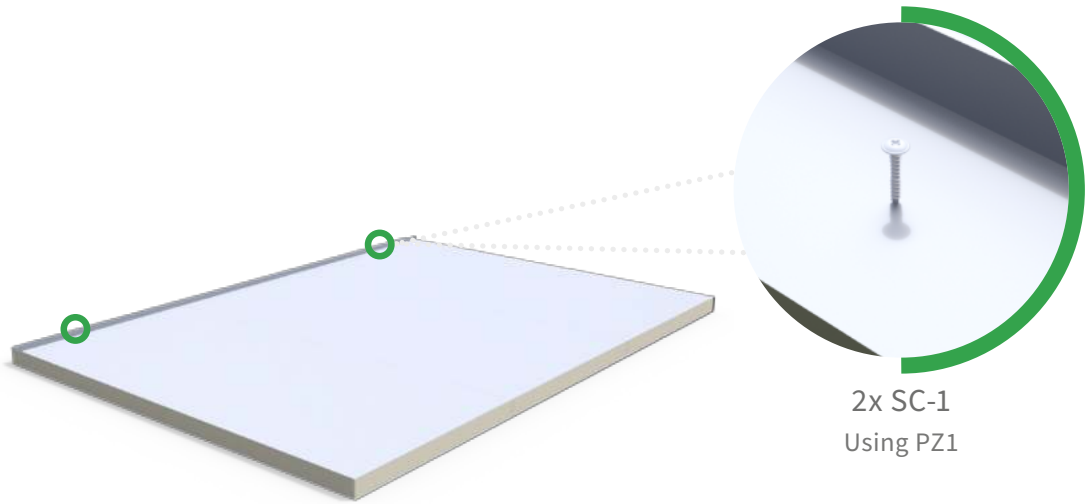

Place the base flashing labelled BF-12 on top of the floor panel along the back edge. Push the floor panels together tightly so the total building width is 3660mm. Screw the base flashing into the floor panels using 2x SC-1 screws at approx. 300mm from each end using the pre-drilled holes.

Note: If the back base flashing overhangs the floor panels then adjust the floor panels outwards so that they sit level with the outside edge of the back base flashing.

05

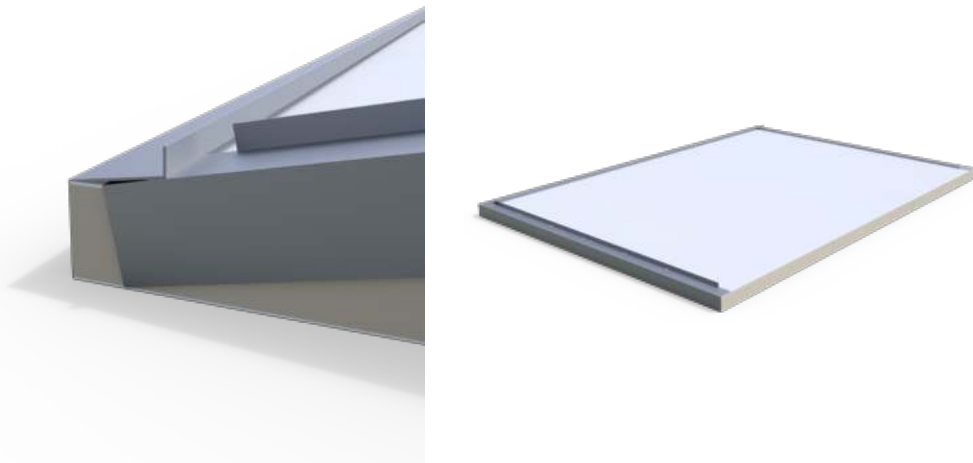

Slide each of the side base flashings labelled BF-8N under the back base flashing so that they sit square with the outside edges of the floor panels.



06

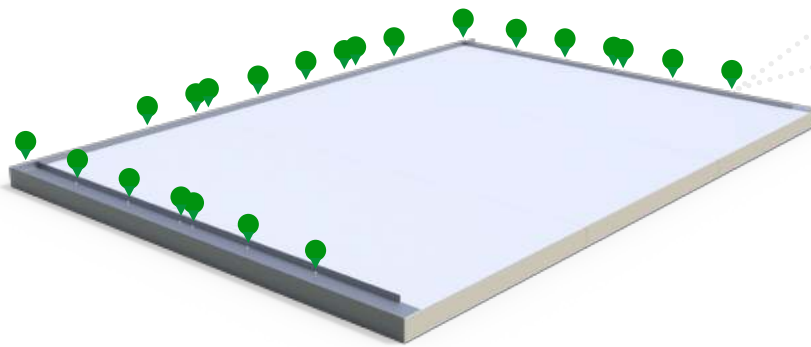

22x SC-1
Using PZ1

Attach the side base flashings to the floor panels using 22x SC-1 screws. These screws will be positioned using the punched holes provided. Be careful not to over tighten these screws which would cause the threads to strip.

07

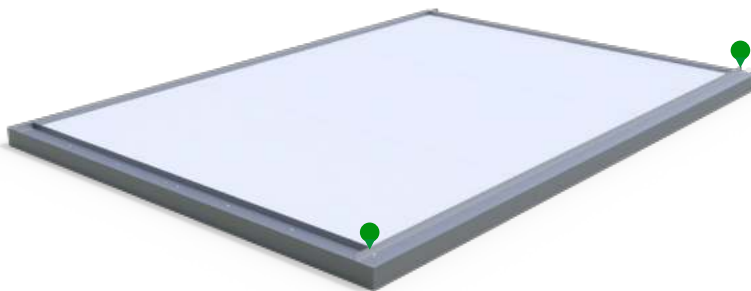

2x SC-1
Using PZ1

Attach the front base flashing labelled BF-8 using 2x SC-1 screws in the two front corners only. This step is to secure the floor panels together for strength whilst the building comes together. You will remove this front section at a later step.



08



Top:
Long Edge

Bottom:
Short Edge

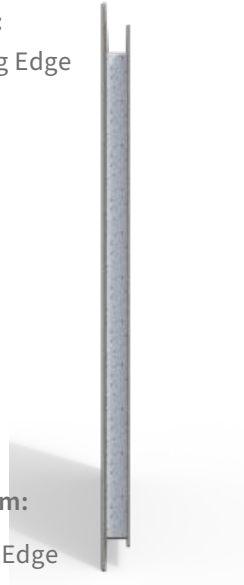

Place the back wall panel labelled BP-8 onto the back left corner of the building on the back base flashing.
Make sure that the panel is placed with the short edge positioned at the bottom and the long edge positioned at the top.

09

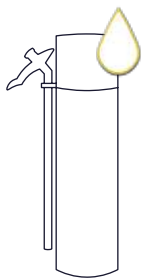

Apply 4 small drops of expanding foam adhesive glue onto the inner left hand side of the wall panel BP-8, making sure that the adhesive is applied only to the white insulating foam of the panel.

Note: Wear a face mask and gloves when using the adhesive.



10

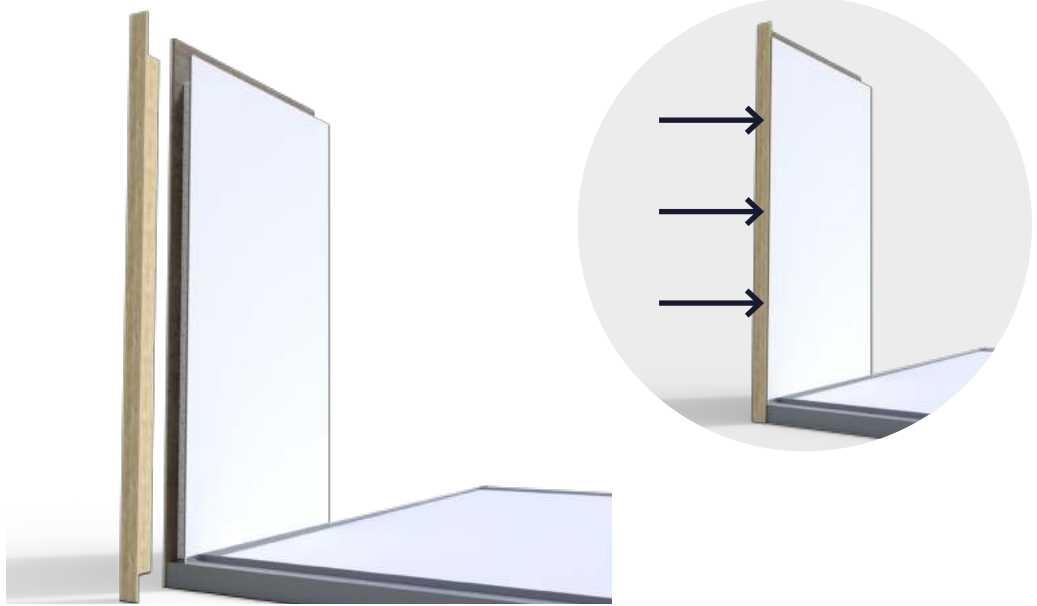

Push the corner post CP-8 into the glued slot, ensuring the bottom of the ply is in line with the floor. Ensure the post is pressed tightly into the insulation all the way up.

11

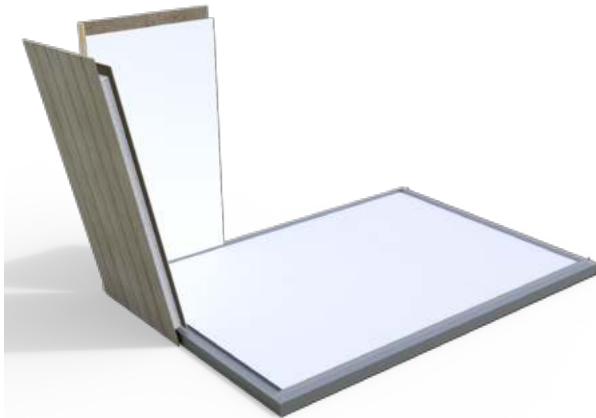

Place the wall panel labelled L-2/WT onto the left hand side floor flashing towards the back of the building.

Push this panel upright and against the back panel BP-8 to create a corner.



12

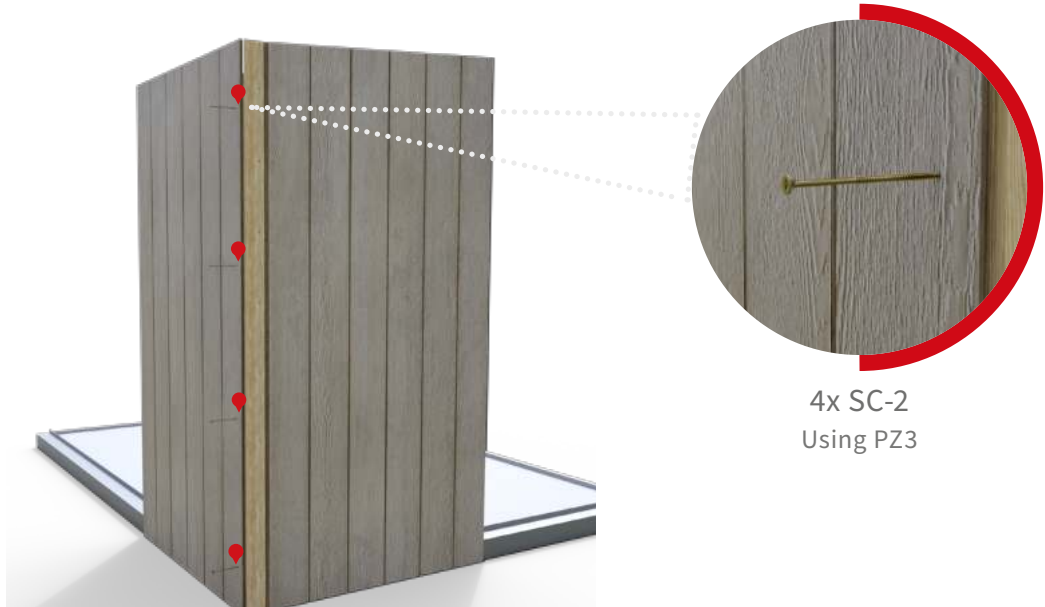

From the outside of the building, screw the wall panel BP-8 into the wall panel L-2/WT using 4x SC-2 screws. Use the pilot hole indicators at the rear corner for the screw locations, and use the 5mm long series drill bit to pilot a hole 90mm deep. Ensure the ply surface is level with the side wall cladding panel to make sure the panels are straight. Fit the screws from the bottom pilot hole and work up to the top. *Note: Pilot hole indicators are only to be drilled into where a corner is being joined between rear and side panels.*

13



Ensure that the wall panel is pushed tightly against the floor panel.



14

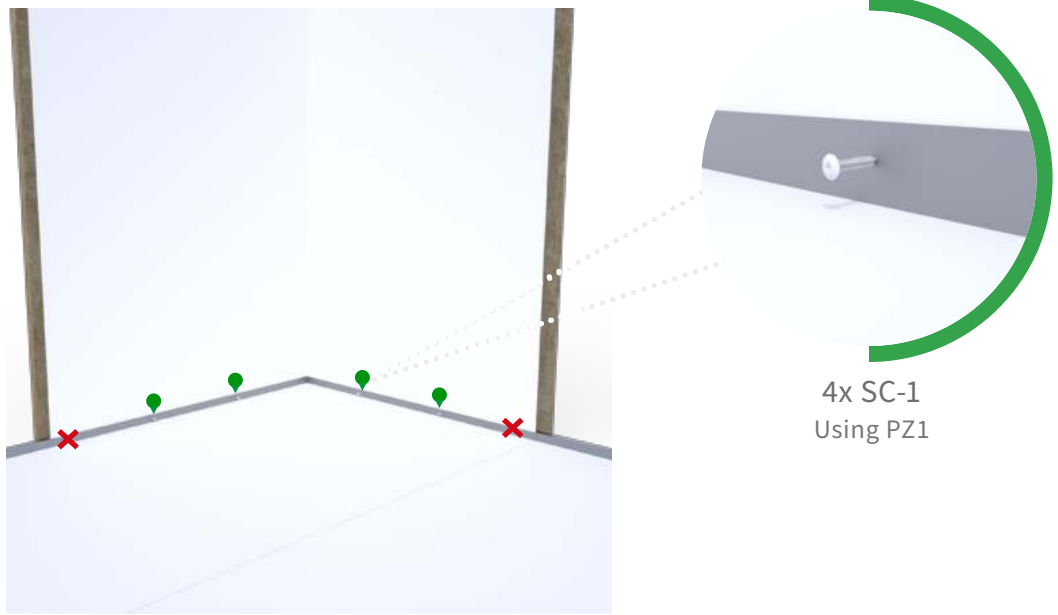

On the inside of the building, you will find punched holes along the inside of the base flashing. Fit 4x SC-1 in the positions shown above using the punched holes as your pilot guide. This will secure the base flashing to the wall panel.

Be careful not to over-tighten these screws which would cause the threads to strip.

15



Place the next BP-8 wall panel next to the already fitted BP-8 panel at the back of the building. Leave a small gap between the panels for now.



16

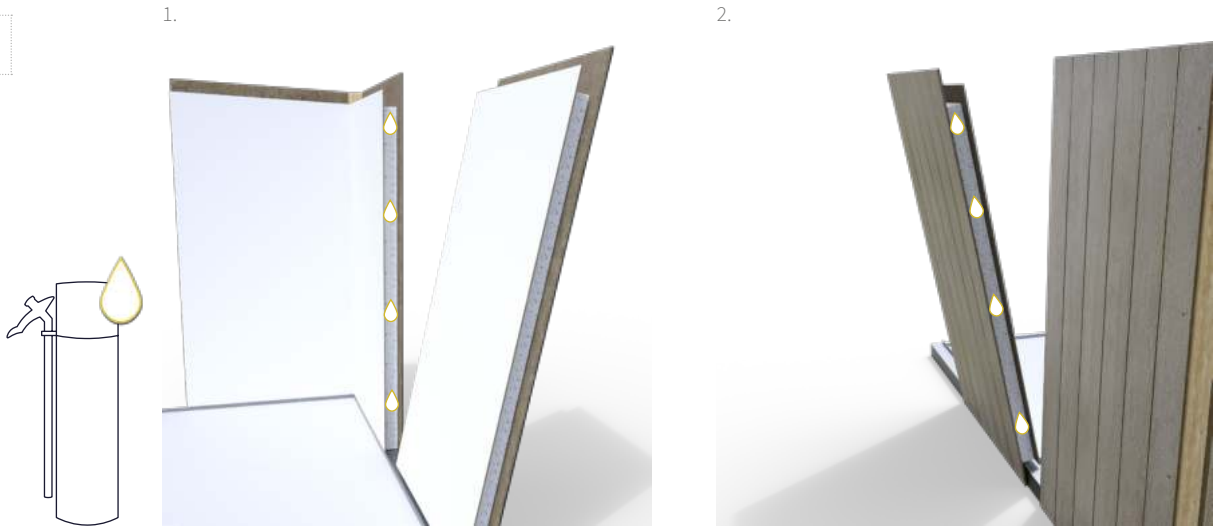

Spray 4 drops of expanding foam adhesive down the inside groove of both back panels, making sure that the foam is applied only to the insulating foam of each panel.

17

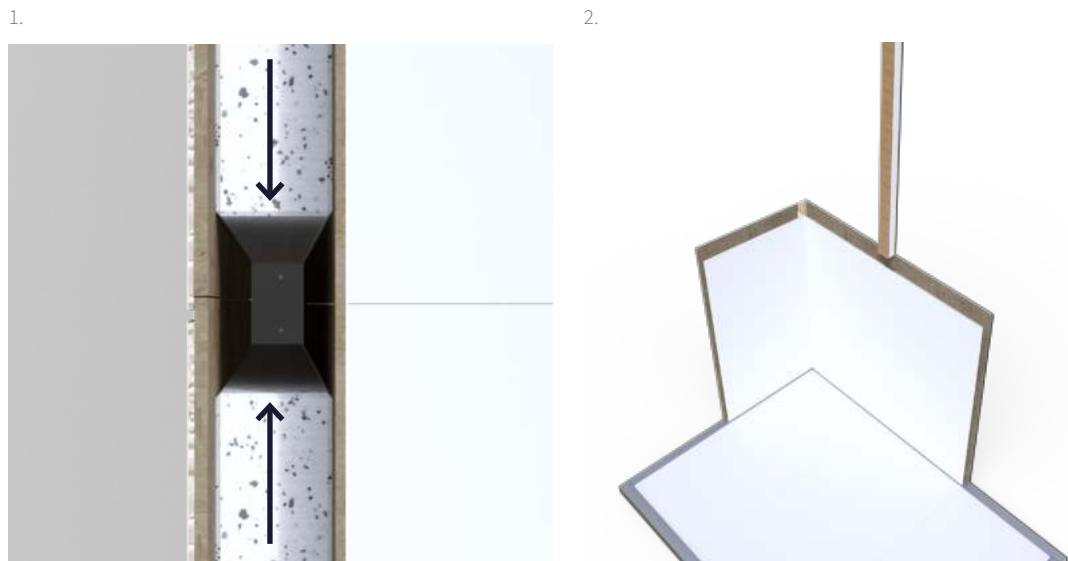

Now push the wall panels together, making sure the exterior cladding joints overlap each other. Then immediately drop the insert labelled RT-8 down into the cavity between the panels from above. RT-8 should have the thicker edge of ply (12mm) facing into the inside of the building. The RT should be level with the interior wall insulation.

Top Tip: If you have restricted height above your building then you can cut the insert into two pieces and drop them down separately into the gap.

18

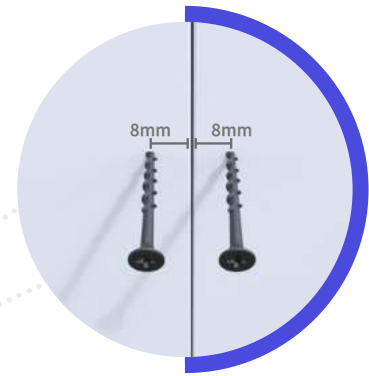
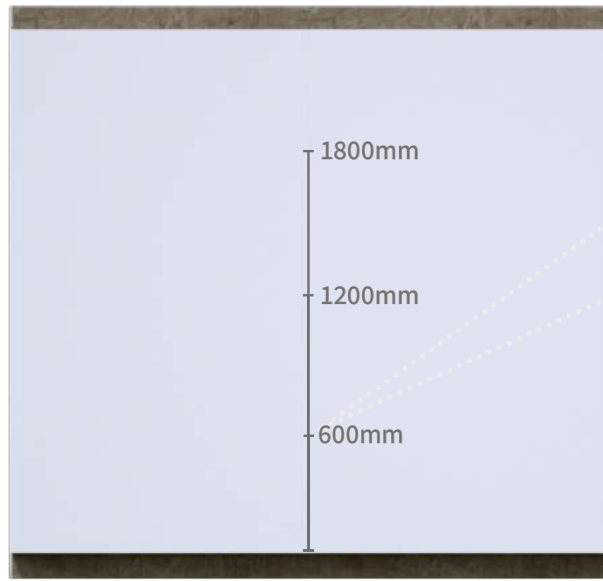

6x SC-8
Using PZ2

On the inside of the building where the wall panels join, measure 600mm up from the floor and fit an SC-8 screw at 8mm on either side of the join. Repeat at 1200mm up from the floor and then again at 1800mm from the floor - using 6x SC-8 screws. These screws will be hidden by the interior wall trims when they are fitted at the end of this manual.

19

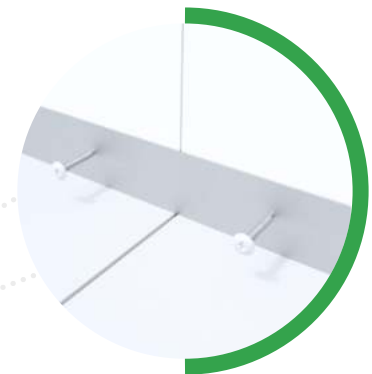
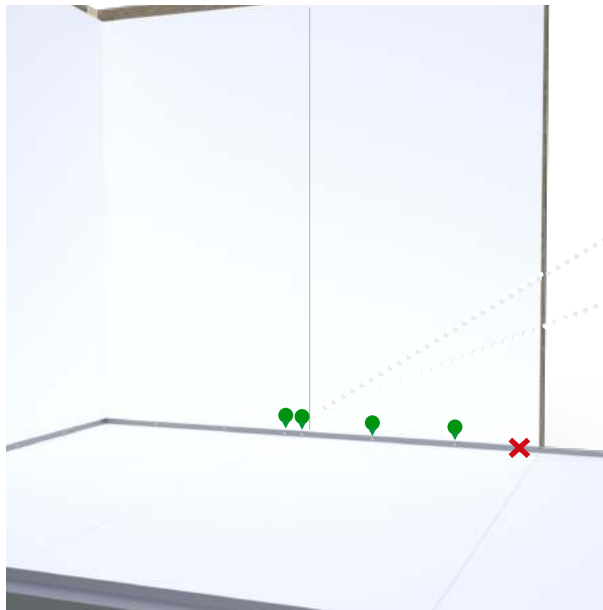

4x SC-1
Using PZ1

On the inside of the building near the floor, you will find punched holes along the inside of the base flashing. Fit 4x SC-1 in the positions shown above using the punched holes as your pilot guide. This will secure the base flashing to the wall panel. Be careful not to over-tighten these screws which would cause the threads to strip.



20

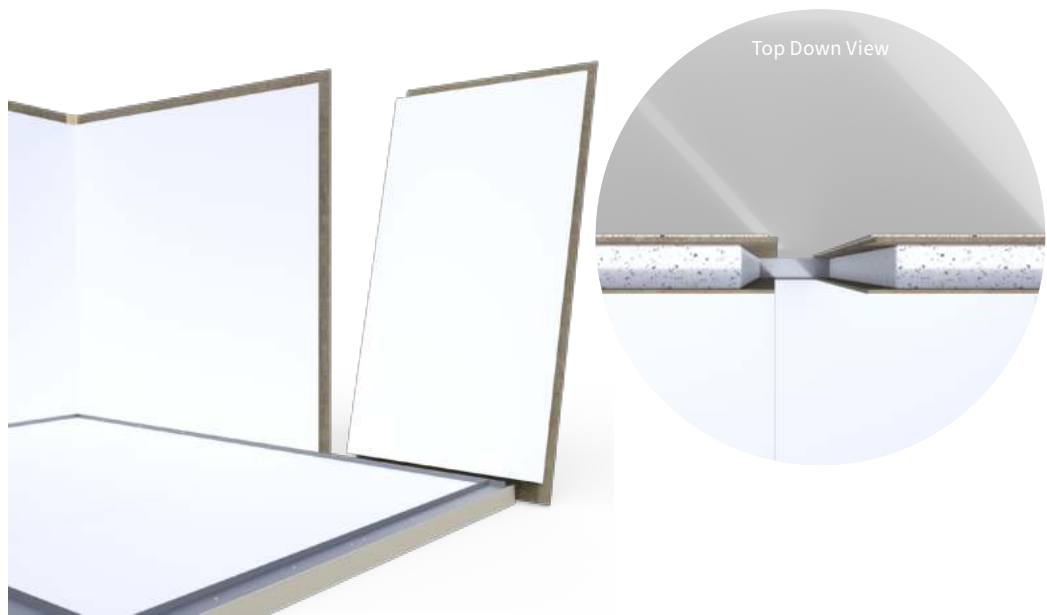

Place the wall panel BP-8F next to the already fitted BP-8 panel at the back of the building. Leave a small gap between the panels for now.

21

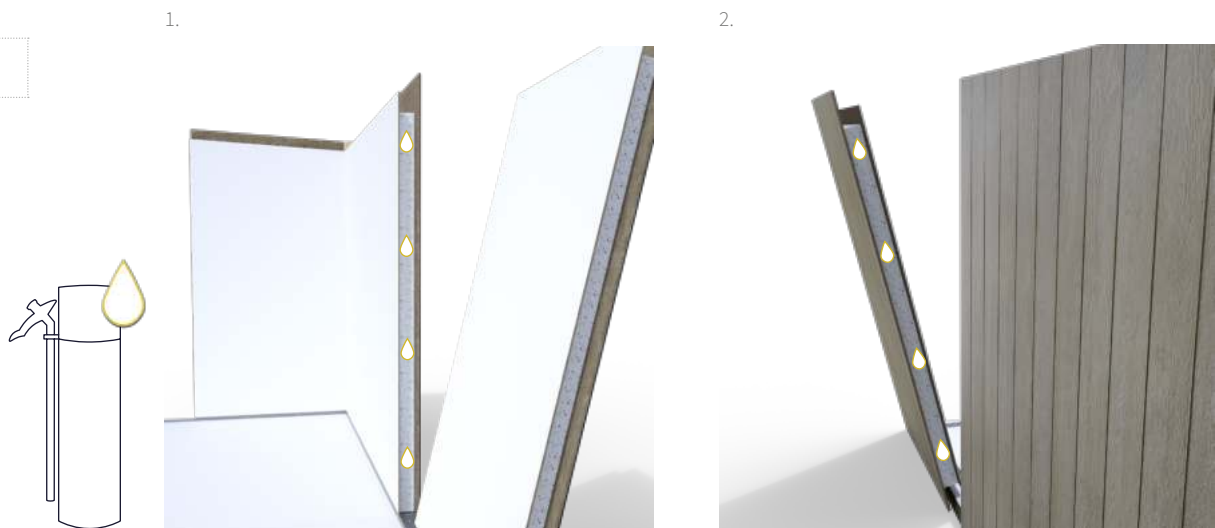

Spray 4 drops of expanding foam adhesive down the inside groove of both back panels, making sure that the foam is applied only to the insulating foam of each panel.



22

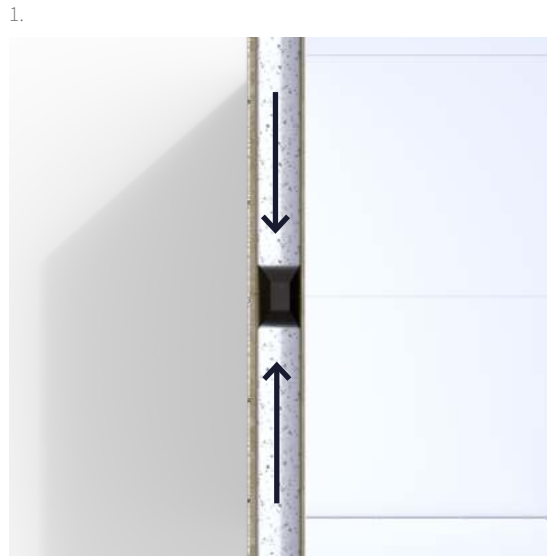

Now push the wall panels together, making sure the exterior cladding joints overlap each other. Then immediately drop the insert labelled RT-8 down into the cavity between the panels from above. RT-8 should have the thicker edge of ply (12mm) facing into the inside of the building.

23

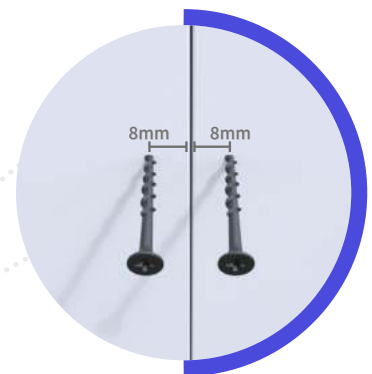
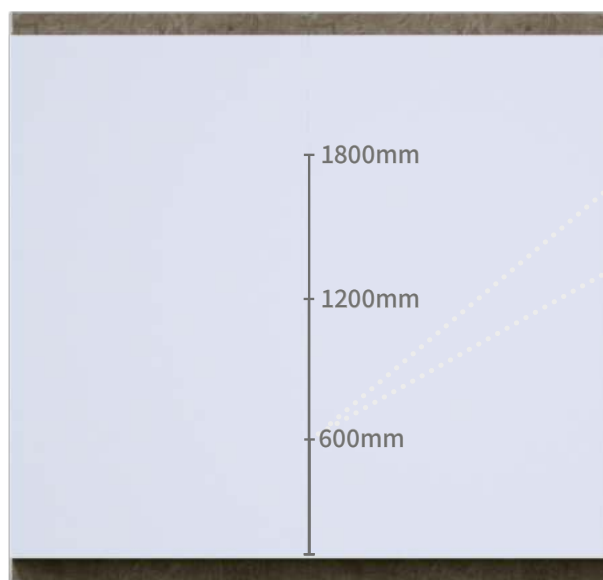

6x SC-8
Using PZ2

On the inside of the building where the wall panels join, measure 600mm up from the floor and fit an SC-8 screw at 8mm on either side of the joint. Repeat at 1200mm up from the floor and then again at 1800mm from the floor - using 6x SC-8 screws.

These screws will be hidden by the interior wall trims when they are fitted at the end of this manual.



24

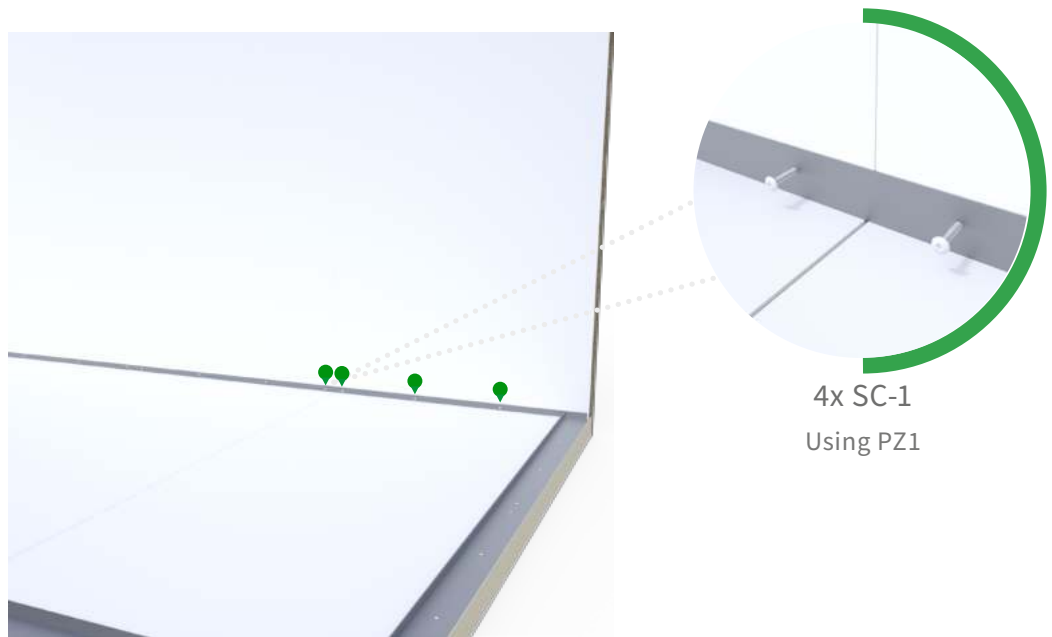

On the inside of the building, you will find punched holes along the inside of the base flashing. Fit 4x SC-1 in the positions shown above using the punched holes as your pilot guide. This will secure the base flashing to the wall panel.

Be careful not to over-tighten these screws which would cause the threads to strip.

25

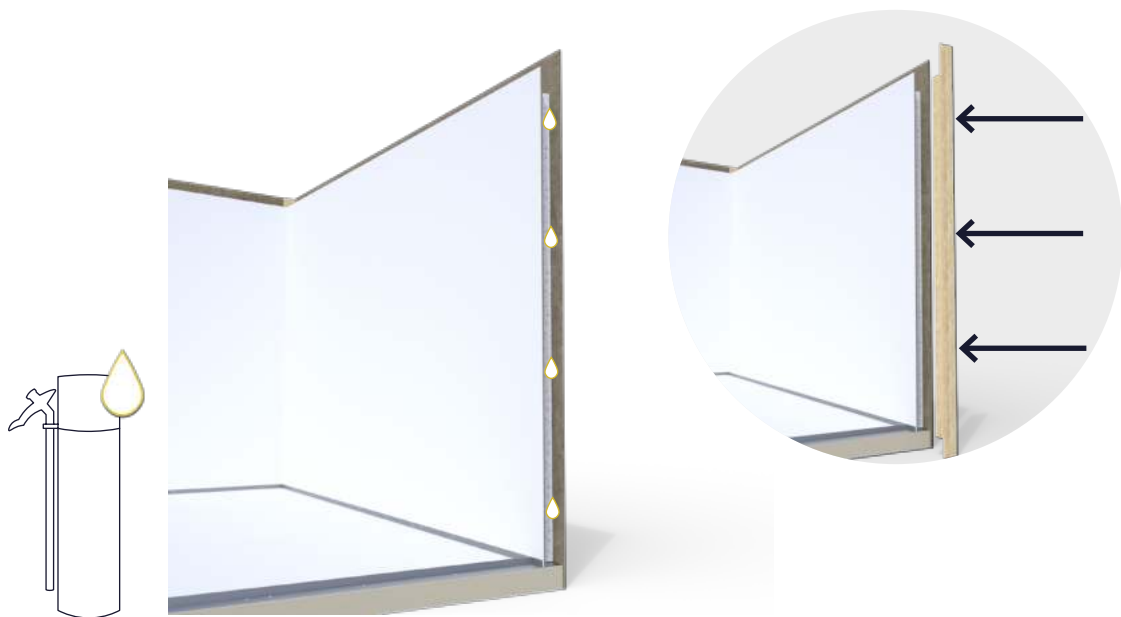

Spray 4 drops of expanding foam adhesive onto the white foam insulation inside the groove of the back corner wall panel labelled BP-8. Then push the post labelled CP-8 into the end of that right hand panel, making sure the taller ply of the outside edge comes up to the roof line, and the smaller ply overhang overlaps the floor panel. Ensure the post is pressed tightly into the insulation all the way up.

26



26



Place the right wall panel R-2/WT against wall panel BP-8 in the back right corner and lift to sit upright. Screw the wall panels together from the outside using 4x SC-2 screws using the pilot hole indicators located at the back of the building.

Note: Pilot hole indicators are only to be drilled where a corner is being joined between back and side panels.

27

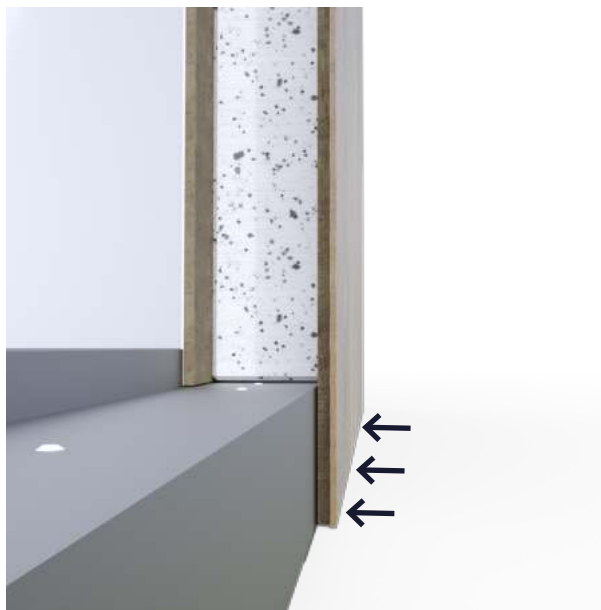

Ensure that the wall panel is pushed tightly against the floor panel.



28

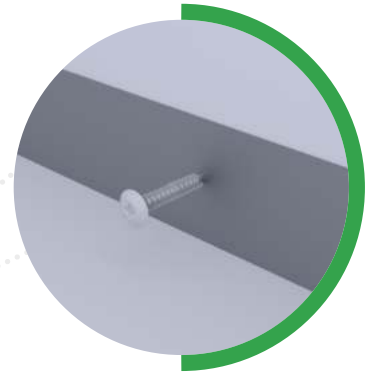
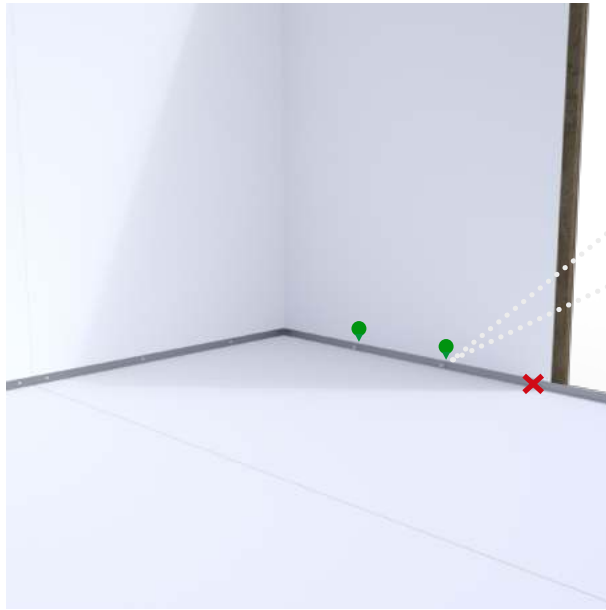

2x SC-1
Using PZ1

On the inside of the building, locate the punched holes on the base flashing as shown above. Use 2x SC-1 screws to secure the wall panel R-2 onto the base flashing.

29



Unscrew and remove the front base flashing from the front of the building and put to one side.

28



30



Top Down View

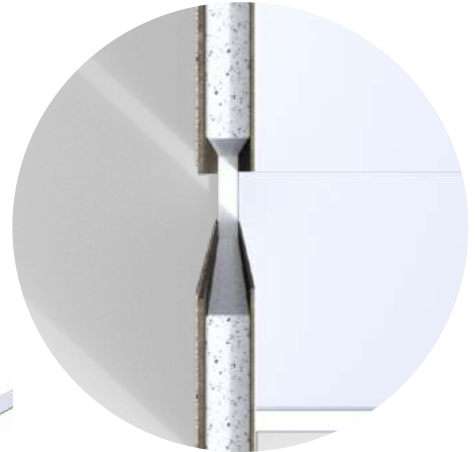

Place wall panel L-1 next to the already fitted L-2/WT wall panel, but leave a small gap.

31

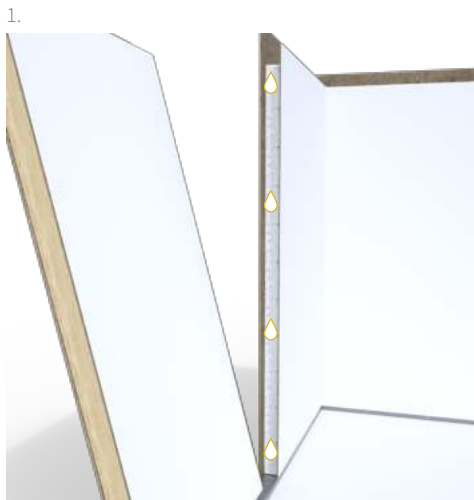
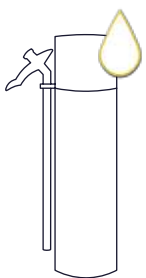

Spray 4 drops of adhesive expanding foam into the sides of the wall panels labelled L-1 and L-2/WT, being careful to apply the adhesive to only the white foam insulation of each panel.



32

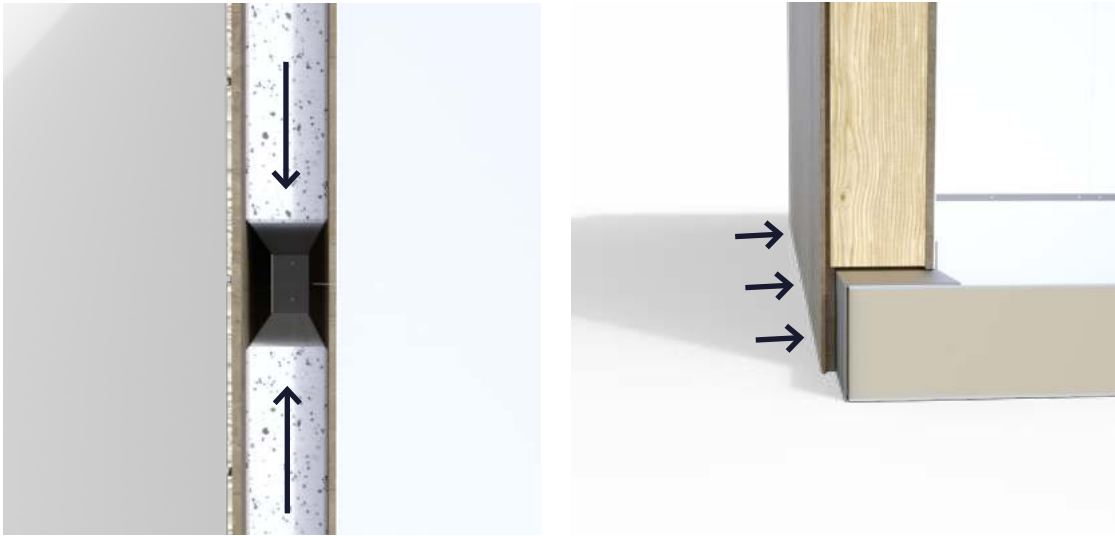

Now push the wall panels together, making sure the exterior cladding joints overlap each other.

Ensure that the wall is pushed tightly against the floor flashing.

33

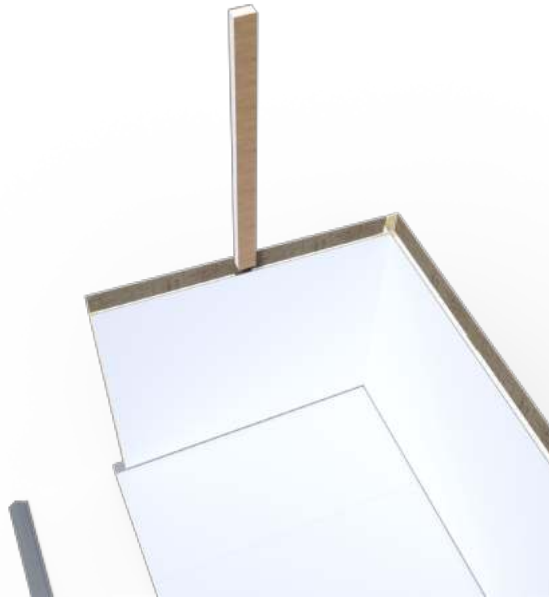

Immediately drop the insert labelled ST-4 down into the cavity created. Remember to have the thicker edge of ply facing inwards.



34

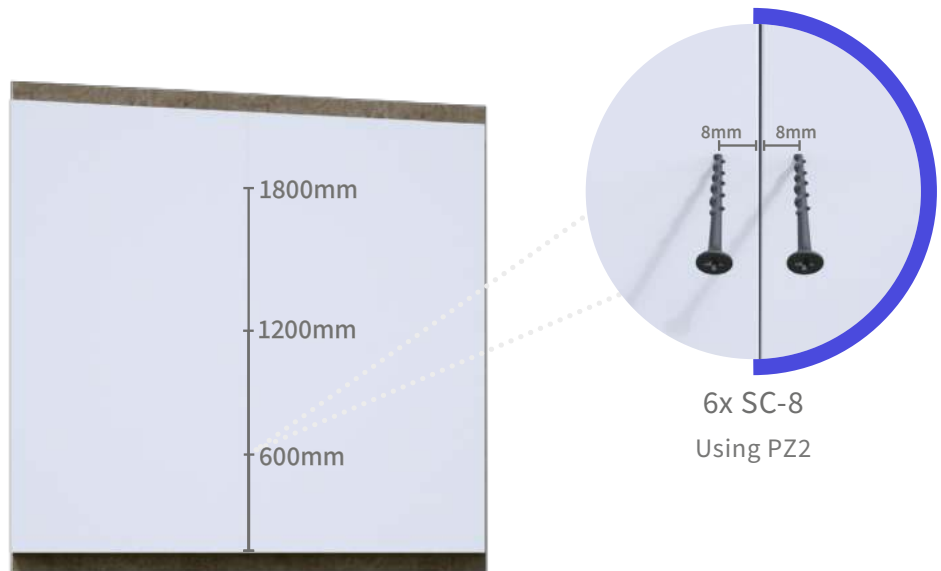

On the inside of the building where the wall panels join, measure 600mm up from the floor and fit an SC-8 screw at 8mm on either side of the join. Repeat at 1200mm up from the floor and then again at 1800mm from the floor - using 6x SC-8 screws. These screws will be hidden by the interior wall trims when they are fitted at the end of this manual.

35

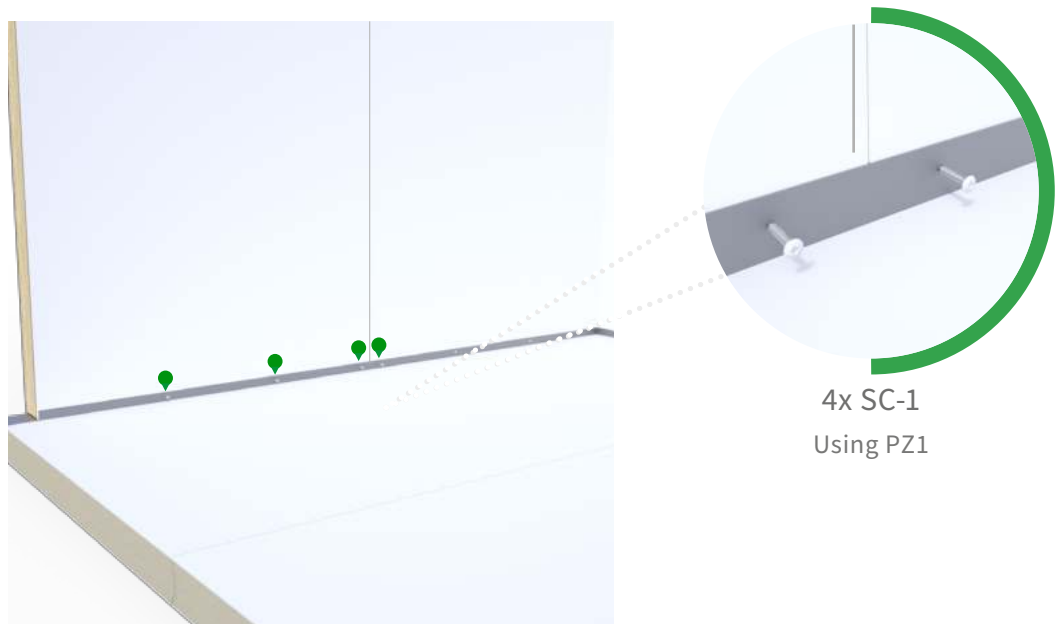

Inside the building, locate the punched holes on base flashing as shown above. Screw the base flashing and wall panels together using 4x SC-1 screws in the locations shown.



36

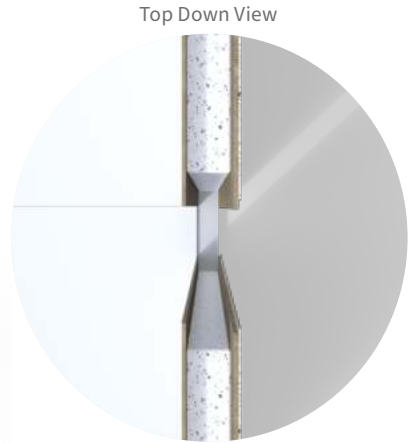

Place wall panel R-1 next to the already fitted R-2/WT wall panel, but leave a small gap.

37

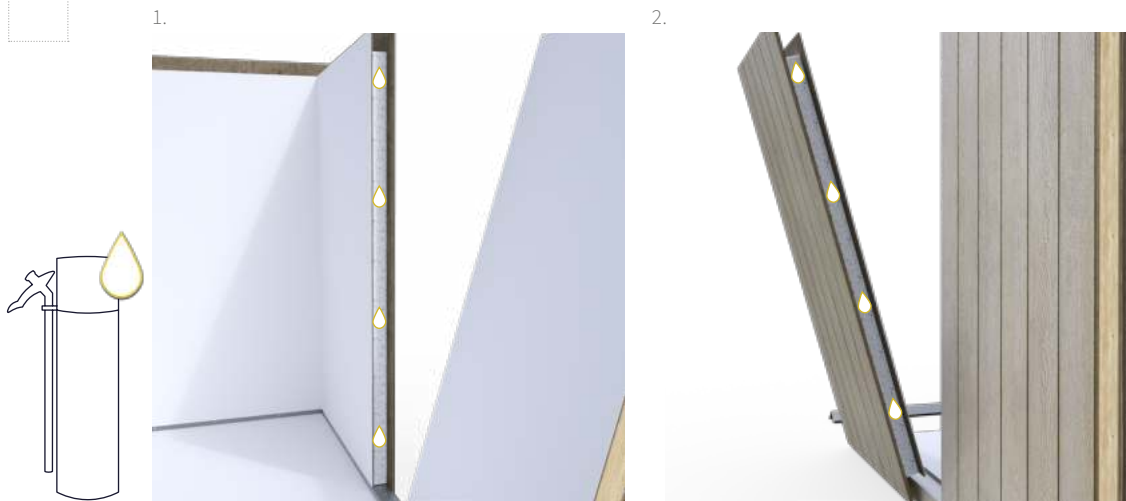

Spray 4 drops of adhesive expanding foam into the sides of the wall panels R-1 and R-2/WT. Be sure to apply the adhesive to the white foam insulation of the panel.



38



Now push the wall panels R-1 and R-2/WT together, making sure the exterior cladding joints overlap each other. Ensure that the wall is pushed tightly against the floor flashing.

39



Drop the insert labelled ST-4 down into the groove created. Remember to have the thicker edge of ply facing inwards.



40

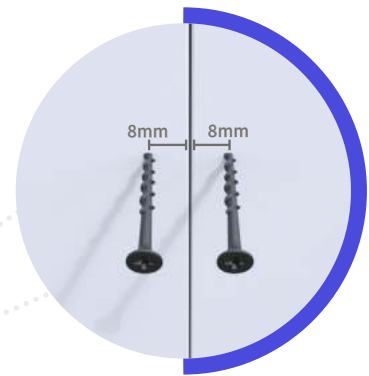
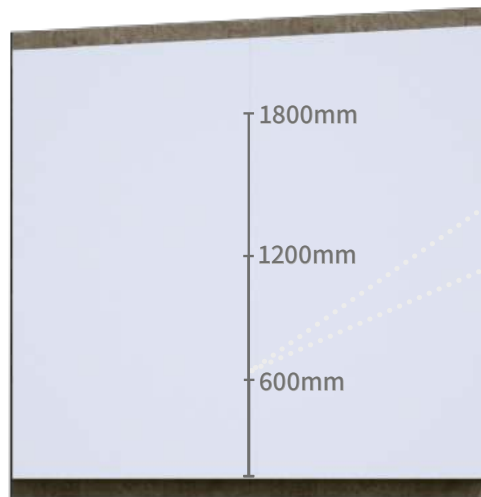

6x SC-8
Using PZ2

On the inside of the building where the wall panels join, measure 600mm up from the floor and fit an SC-8 screw at 8mm on either side of the join. Repeat at 1200mm up from the floor and then again at 1800mm from the floor - using 6x SC-8 screws. These screws will be hidden by the interior wall trims when they are fitted at the end of this manual.

41

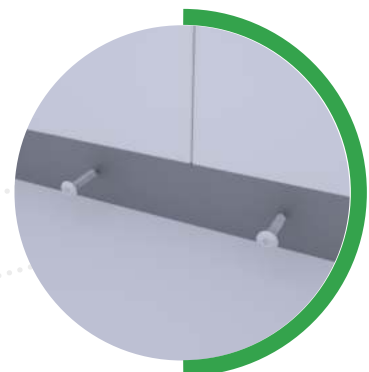
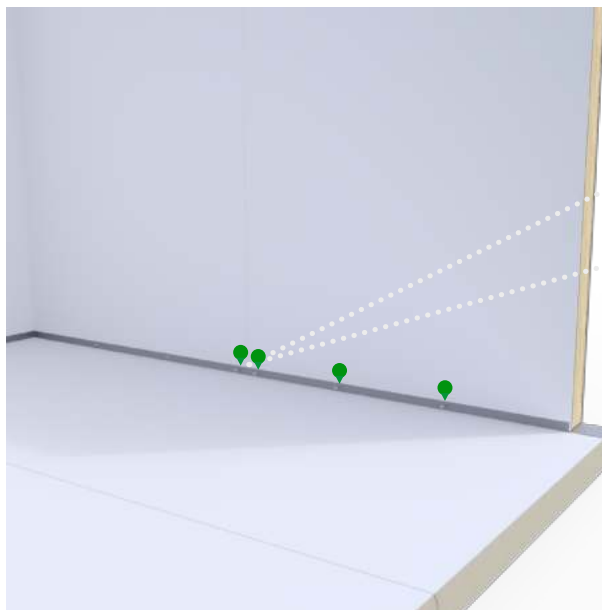

4x SC-1
Using PZ1

Inside the building, locate the punched holes on base flashing as shown above. Screw the base flashing and wall panels together using 4x SC-1 screws in the locations shown.



42



At this point in the build, check that the floor panels are still sitting tightly together by pushing from all sides. This is also a good time to check that the walls are sitting tightly and straight together.

43

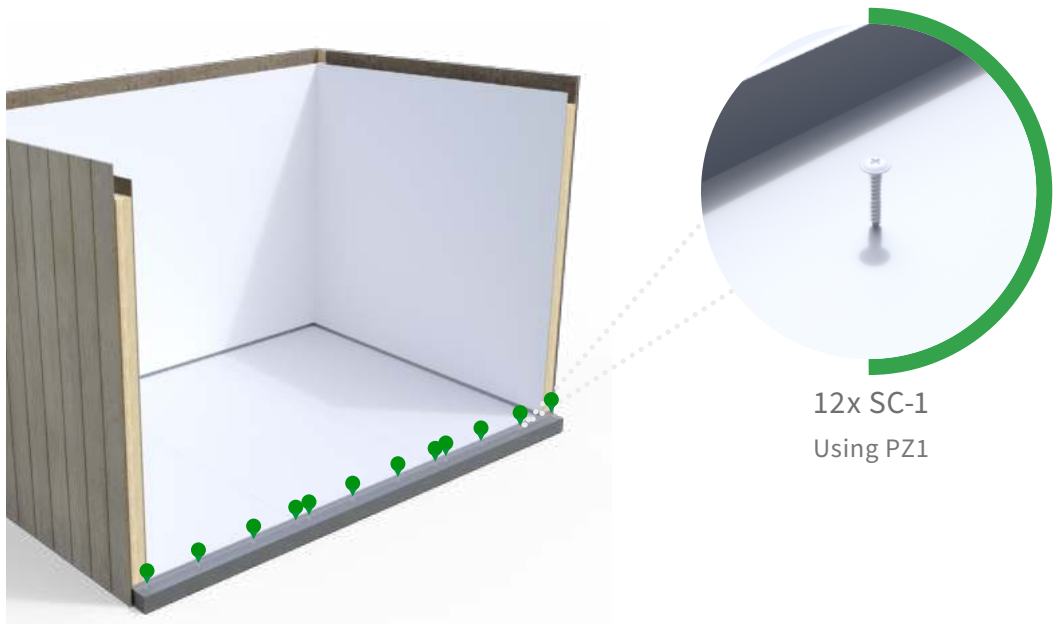

12x SC-1
Using PZ1

Place the front base flashing labelled BF-12 back onto the front of the floor base and use 12x SC-1 screws to attach it to the floor using the punched holes as a guide.



44



Place the under door trim, labelled UDT-6, in the middle of the front floor panels as a guide to where the doors will fit. This trim is the same width as the door-set, so will allow you to place the front wall panels at the correct width. Do not secure the under door trim to the floor at this point.

45

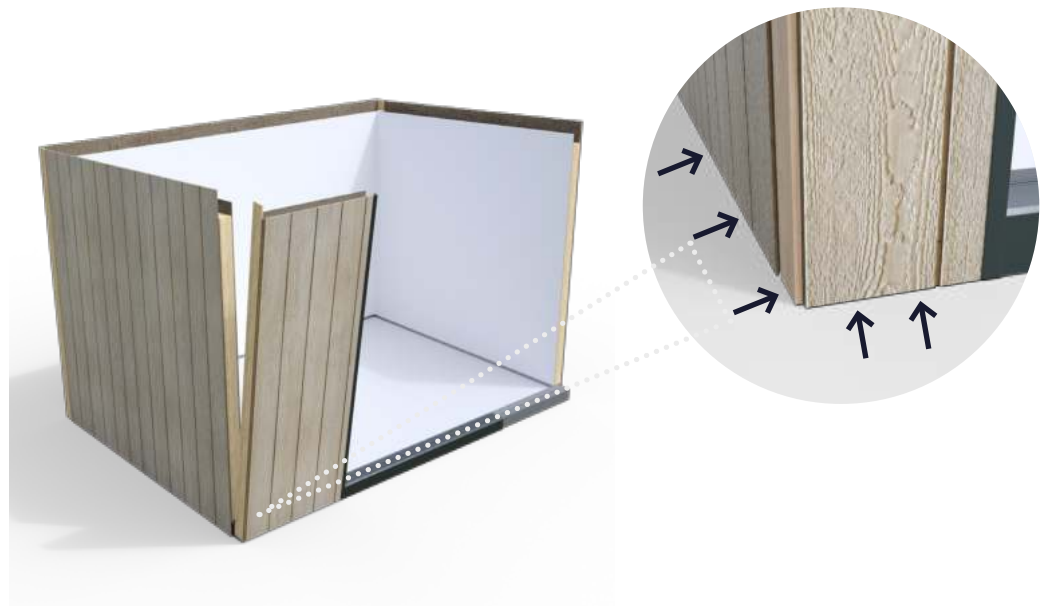

Place the wall panel labelled FL-9 onto the front left of the floor base, ensuring the plywood is pushed tight to the base flashing.



46



4x SC-2
Using PZ3

Use 4x SC-2 screws to attach the wall panel FL-9 onto the wall panel L-1 using the pilot hole indicators on the front of the FL-9 panel. Ensure the ply surface is level with the side wall cladding panel to make sure the panels are straight, then fit the screws from the bottom pilot hole and work up to the top.

47

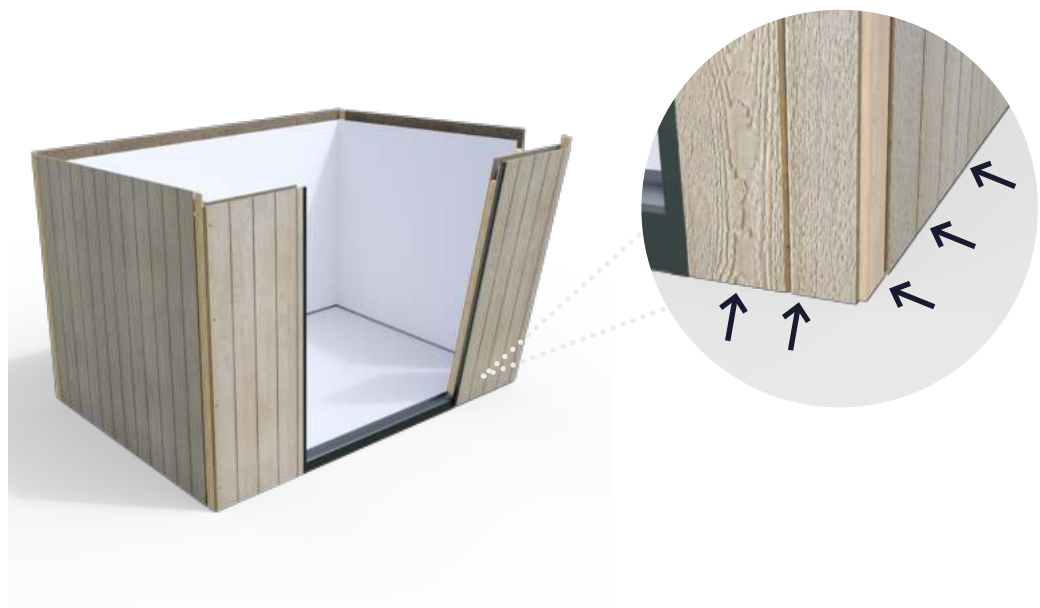

Place the wall panel labelled FR-9 onto the front right of the floor base, ensuring the plywood is pushed tight to the base flashing.



48

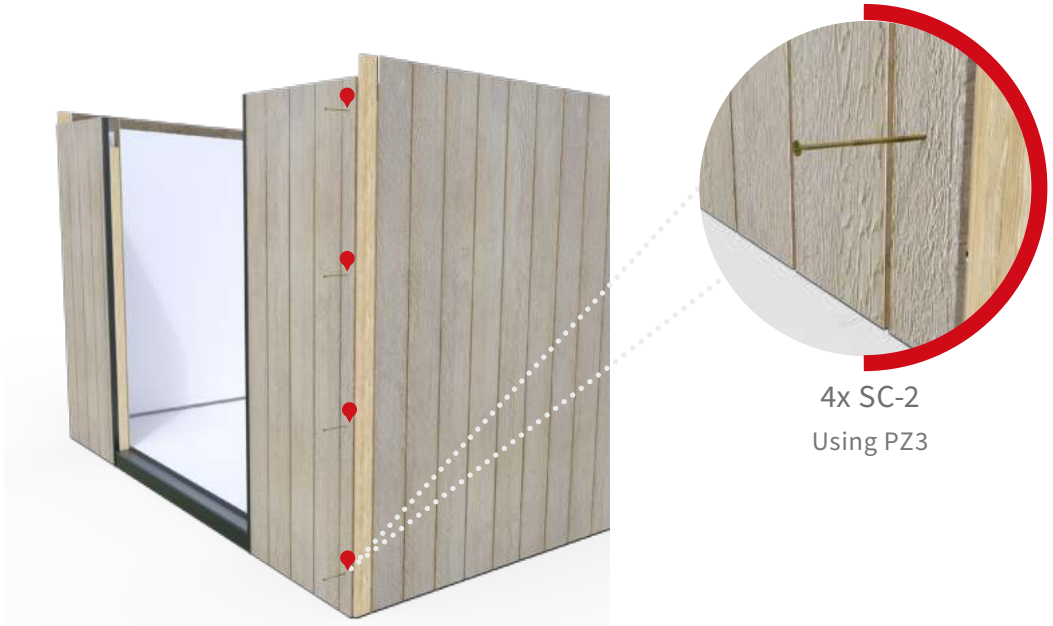

Use 4x SC-2 screws to attach the wall panel FR-3 onto the wall panel R-1 using the pilot hole indicators on the front of the FR-3 panel. Ensure the ply surface is level with the side wall cladding panel to make sure the panels are straight, then fit the screws from the bottom pilot hole and work up to the top.

49

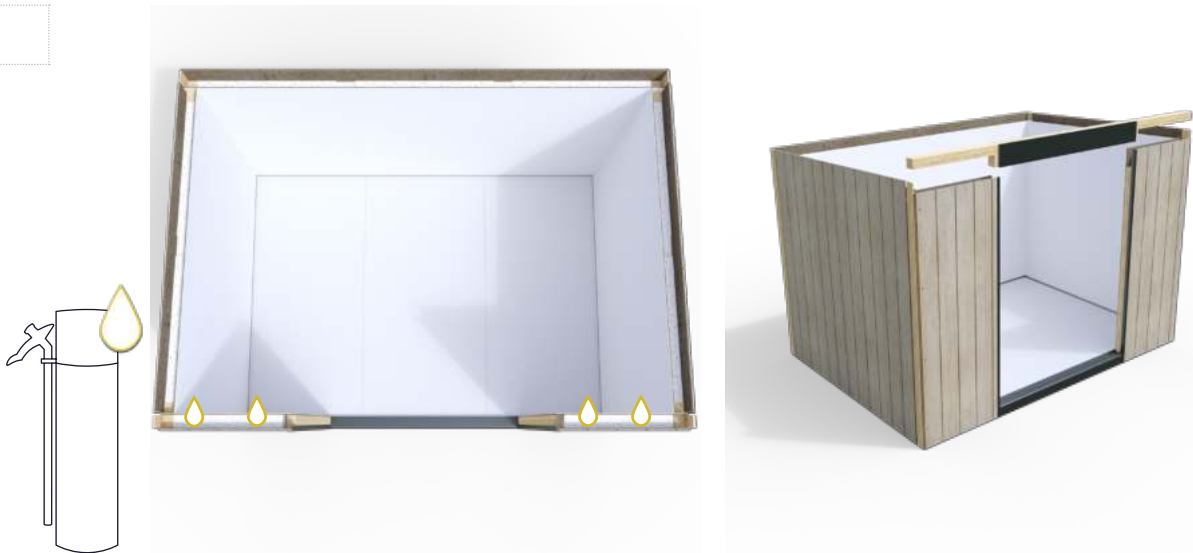

Apply 2 drops of adhesive foam into the top of the FL-9 and FR-9 wall panels. Drop LRS-6/12 into the grooves of the wall panels you've just installed. This will sit on top of the door supports which are built into FL-9 and FR-9.



50

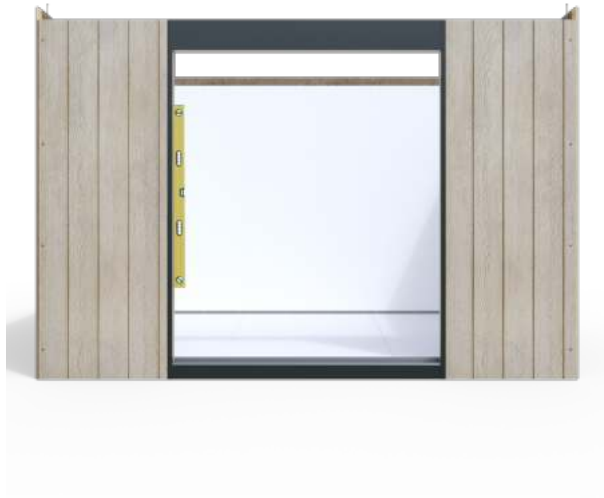

Use a spirit level to ensure the panels around the door are square and upright. You should place the level on the both the inside and outside of the door frame. The more care taken in this step, the easier the doors are to install further through the process.

Note: If the door opening is not level then push the wall sections until they measure as level.

51



2x SC-2
Using PZ3

Using 2x SC-2 screws, measure 25mm in from the ply internal face at the top corners of the roof and fit one screw into each corner at this location, screwing down through the ends of the LRS-6 beams and into the corner post below. Drilling a pilot hole with the 5mm bit will assist with fitting the screw.



52

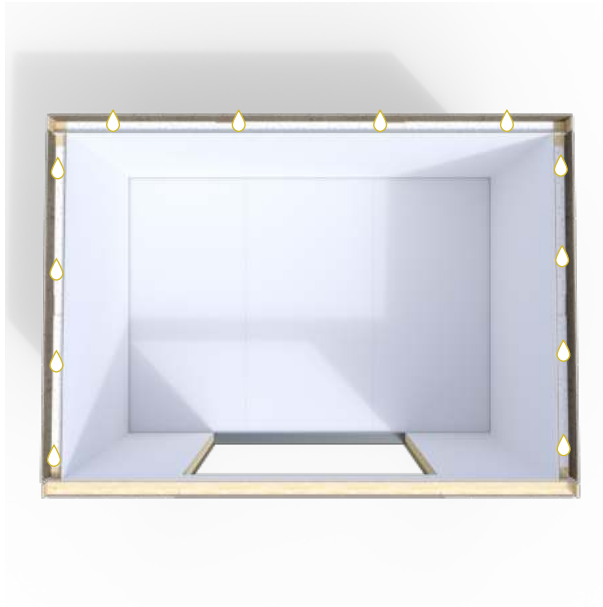
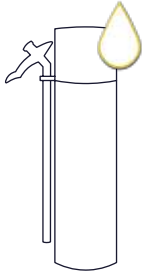

Spray 4 drops of expanding adhesive down the groove along the top of each of the remaining wall panels (back wall, left wall and right wall).

53



Locate the 2 x RB-8 ringbeams, and the back ringbeam labelled RB-12. Drop an RB-8 ringbeam into the top groove of the wall panels on both the left and right hand side of the building. Then drop the RB-12 ringbeam into the top groove of the back wall panel.



54

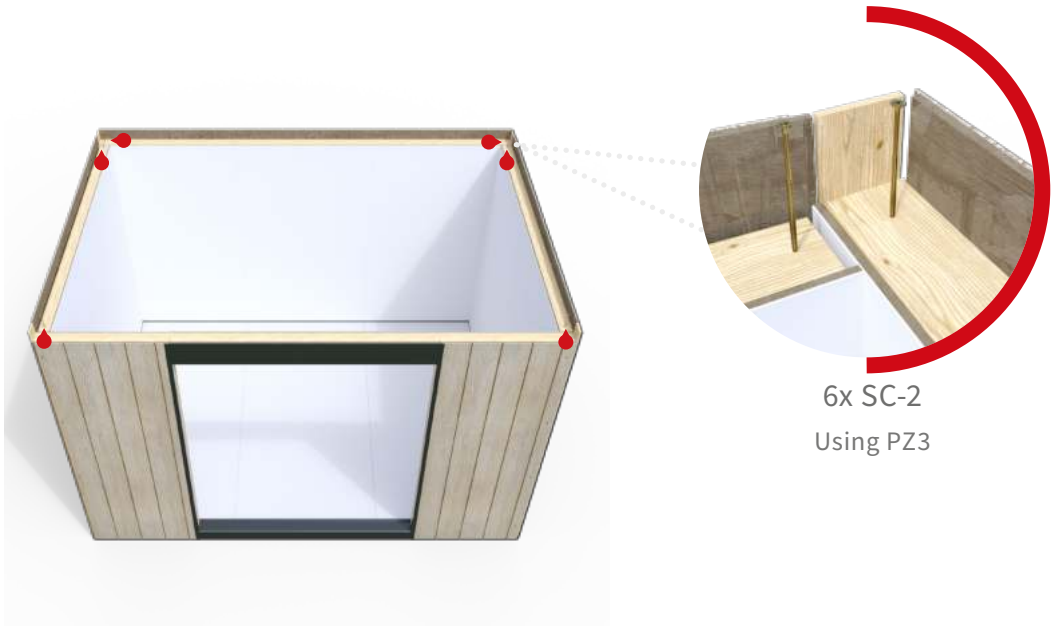

Using 6x SC-2 screws, fit one screw 25mm from the end of each of the 3 ring beams to secure them into the wooden posts below.

55



Remove the under door trim labelled UDT-6 and apply clear silicone along the front and top of the BF-12 flashing underneath. Then reinstall UDT-6 and push it in place, ensuring that the ply is on the front (vertical) face behind the metal. Please note this door trim is not screwed in place and is only attached using the silicone.



56

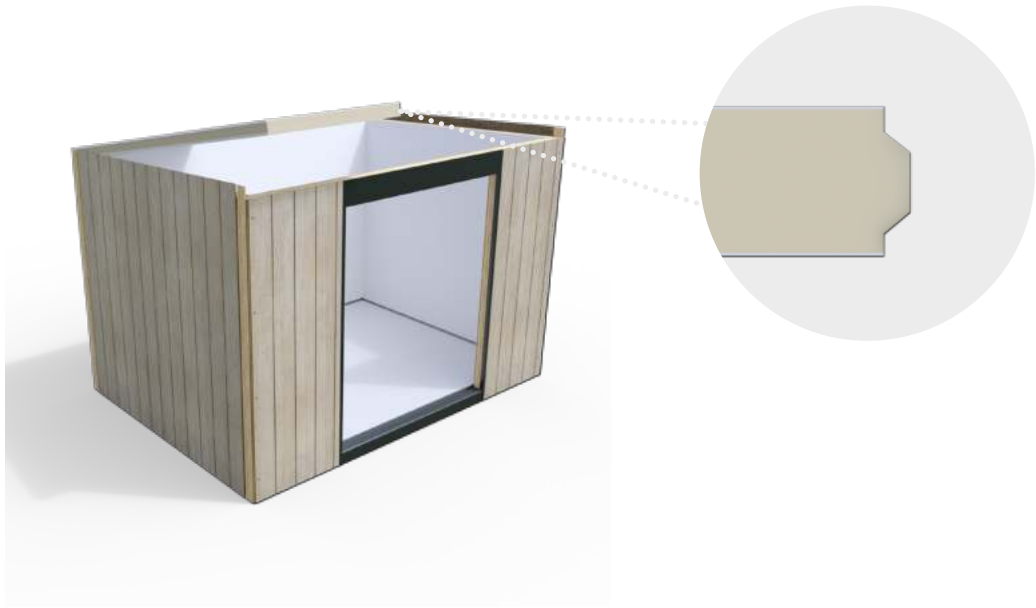

Lift the roof panel RP-8S onto the top of the building and position the roof panel tight to the cladding on the back wall and left hand side of the building, causing an overhang at the front of the building. Be careful to not slide the roof panel along the walls as this could damage the interior finish.

57

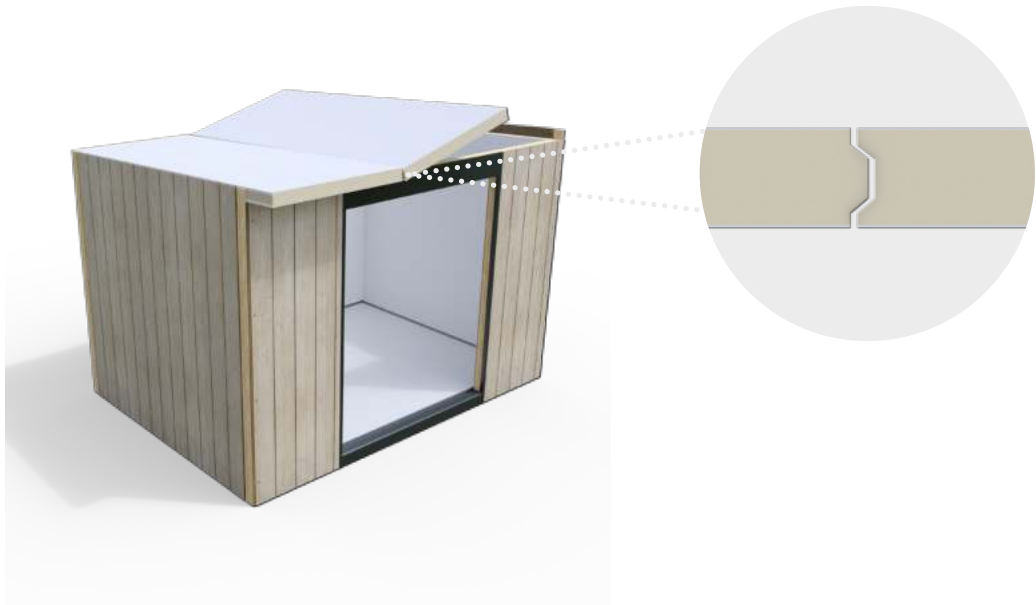

Lift the second roof panel RP-8S on top of the building and line up the groove with the first roof panel. Slot the roof panels together. If you angle the panel as shown in the diagram you will be able to drop the panel into place within the right hand wall cladding.



58

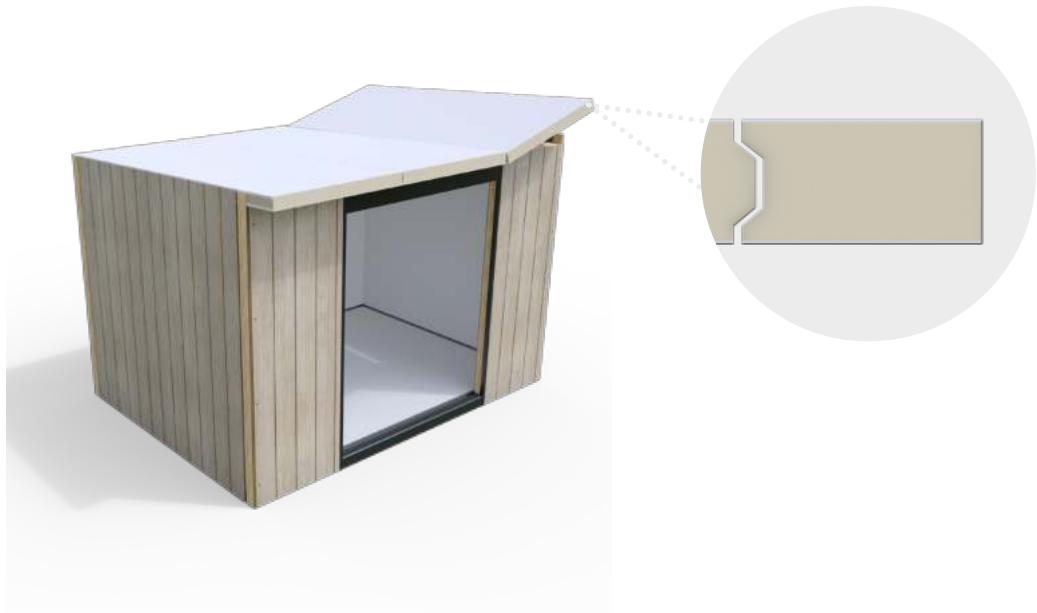

Repeat with the final roof panel RP-8F.

59



At this point check that the roof panels are overhanging the front wall by 290mm.



60

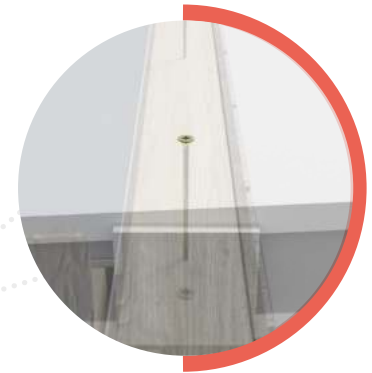
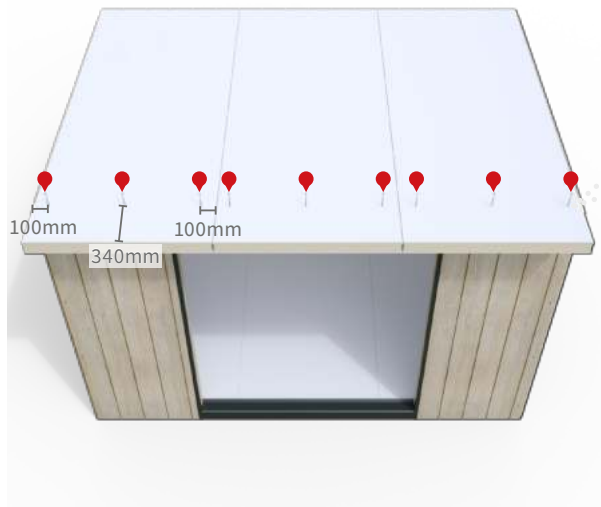

9x SC-2
Using PZ3

Measure 340mm from the front of the roof panels and fit 9x SC-2 screws down through the roof panels into the door support beam below. You will need to install 3 screws per panel. One in the centre of the panel and one 100mm in from each side. Ensure the angle of the screw goes down into the beam underneath and not through the roof into the building.

61

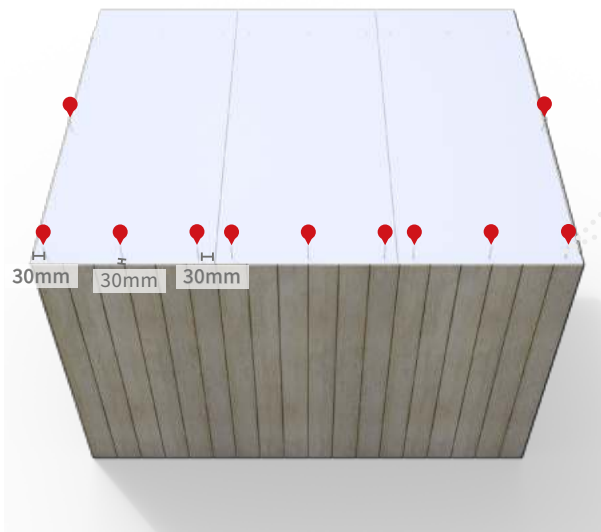

9x SC-2
Using PZ3

Measure 30mm from the back of the roof panels and fit 9x SC-2 screws down through the roof panels into the back walls below. You will need to install 3 screws per panel. One in the centre of the panel and one 30mm in from each side. Fit another 2x SC-2 screws at either side of the roof panel, centrally between the front and the rear side screws.
Take the stickers off the roof panels.



62



Lift the roof sheets (RS-8) into place on top of the roof panels. Place them in position so that they overlap each other. The width of the roof sheets once laid out should be just less than the width of the roof panels, and be central to the roof overall. The front of the roof sheet should sit level with the front of the roof panel. At the back you will find the roof sheet slightly overhangs the back of the roof panel.

63



Once you have established the correct positions remove all but the first sheet. Ensure the front of the roof sheet sits level with the front of the roof panel, and overhangs at the back.



64

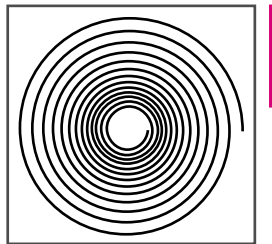

Apply the butyl tape along the ridge of the sheet in the position shown above.

Note: When applying the butyl tape, keep the protective paper over the tape to help guide your line along the roof and to stop the tape becoming too tacky in your hand. Then remove the protective paper once applied to the correct position.

65

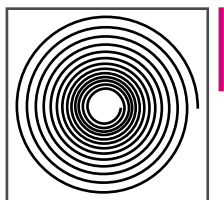

Then install the second sheet by overlapping on top, pressing down along the ridge to create a seal by sandwiching the butyl tape between the ridge of the top and bottom overlapping sheets.



66

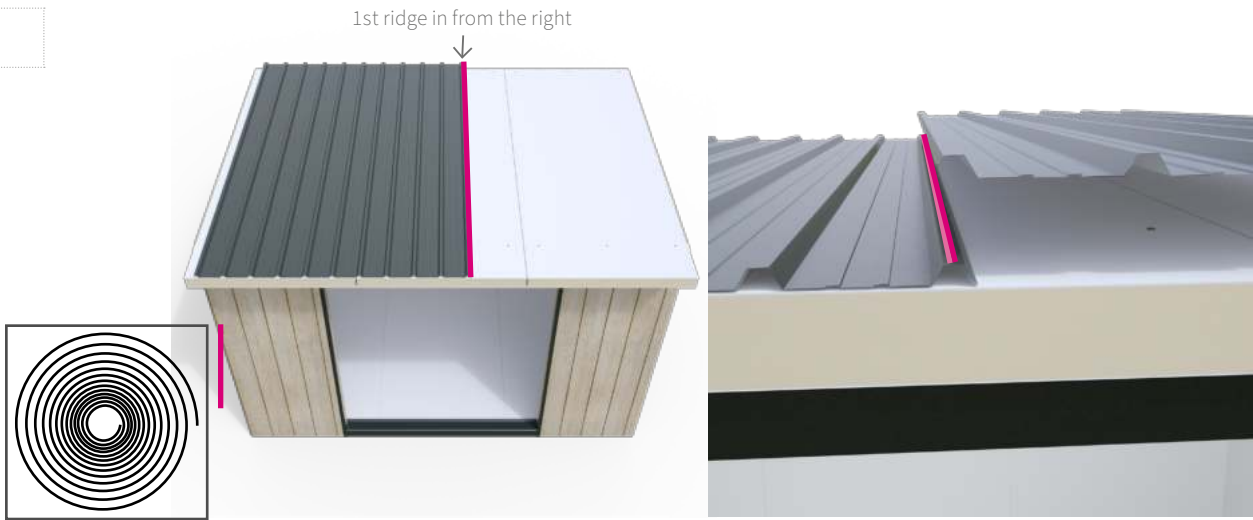

Apply the butyl tape along the ridge of the second sheet in the position shown above. Then install the third sheet by overlapping on top, pressing down along the ridge to create a seal by sandwiching the butyl tape between the ridge of the top and bottom overlapping sheets. Again, ensure the front of the roof sheet sits level with the front of the roof panel.

67



Apply the butyl tape along the ridge of the second sheet in the position shown above. Then install the fourth sheet by overlapping on top, pressing down along the ridge to create a seal by sandwiching the butyl tape between the ridge of the top and bottom overlapping sheets. Again, ensure the front of the roof sheet sits level with the front of the roof panel. Once all of the sheets are fixed, adjust them so they sit centrally across the width of the building.



68

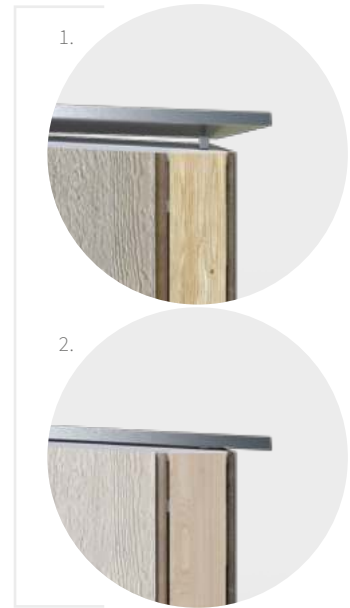

At the back you will find the roof sheet overhangs the back of the roof panel. Lift the roof sheets slightly and slide the foam eaves fillers just underneath the back of the roof sheets so they sit over the back walls below. Later on, when you screw down from above the screw should go down through the roof sheet, then through the foam eaves fillers, down into the roof panel and then into the back ring beam.

69

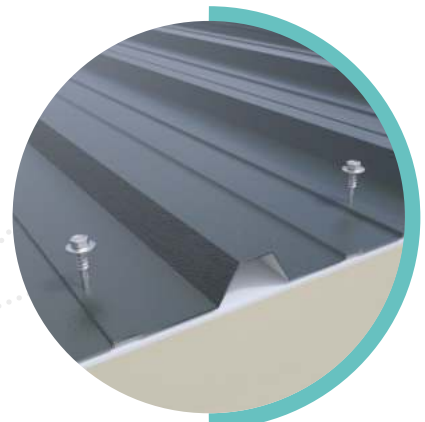
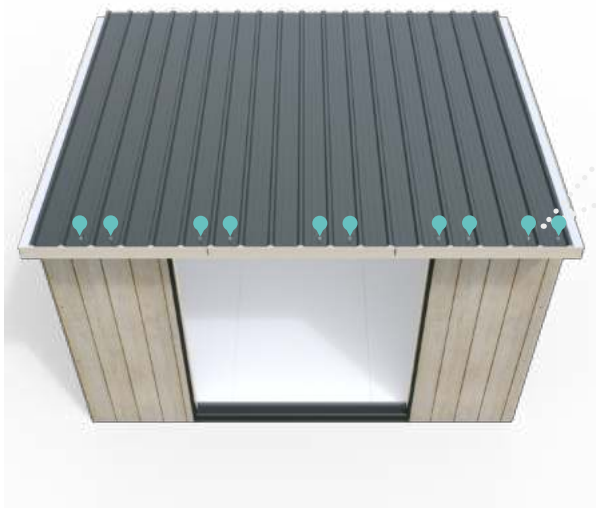

10x SC-3
Using Hex 5/16

At the front of the building measure back 50mm and fit 10x SC-3 stitcher screws into two of the central ridges of each roof sheet. Ensure these screws go into the very slightly raised part of the roof sheet within the furrows. See close up image for details.

Top Tip: To help guide the screw into the roof you should create a divot in the metal by placing the screw in the desired location, then firmly tap the head with a mallet to punch a small dent



70



9x SC-4
Using Hex 5/16

At the back of the building measure 115mm from the back of the roof sheet. Using 9x SC-4 screws, fit one screw through the tall ridge of the roof sheet, through the foam ridge fillers, down into the roof panel and then into the back ring beam below. These screws should be fitted every other ridge from left to right but not in the outer ridges of the roof as we will be covering this with a flashing shortly. Use the image above for the placement of the screws.

Note: Fit the screw at the same angle as the roof so that the washer creates a seal with the roof sheet.

71

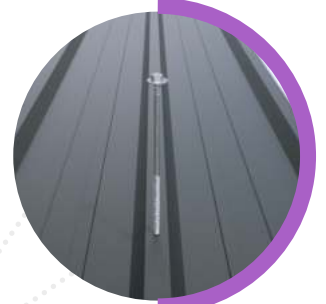
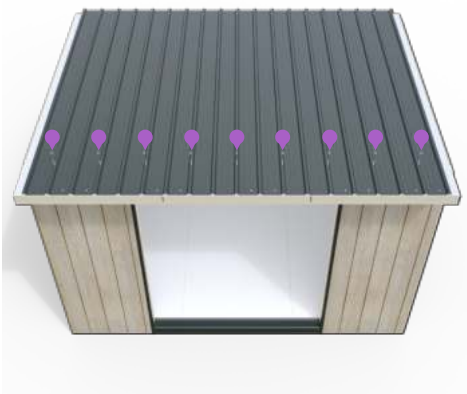

9x SC-4
Using Hex 5/16

Move to the front of the building. Measure back 340mm and screw down using 9x SC-4 screws, again fitting a screw on every other ridge from left to right but not in the outer ridges of the roof.

Note: Fit the screw at the same angle as the roof so that the washer creates a seal with the roof sheet.



72



Apply a bead (line) of clear silicone to the bottom of the UH-8 and UH-4 under hood black board and lift it into place. The black board should overhang the roof by around 5mm.

73

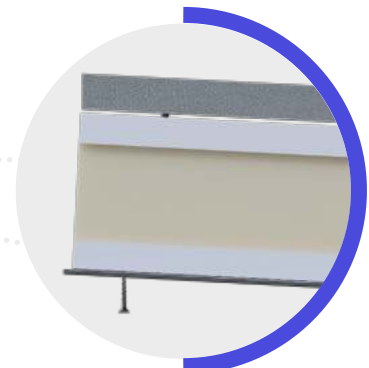
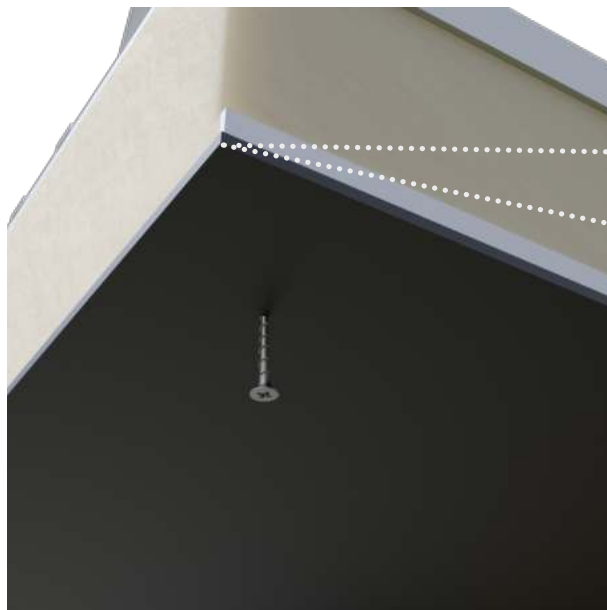

10x SC-8
Using PZ2

When in position the black board will overhang the underhood by around 5mm. Screw the under hood black board UH-8 into place using 10x SC-8 screws into the pre-drilled holes. Be careful to not over tighten these screws.





Top Tip: Whether you've purchased our Paint Pack, or have your own paint already - now is a great time to paint the outside of your building. Painting your building before any exterior metal flashings are fitted saves you having to be very careful cutting in for a tidy finish.

In any case, the building must be painted within 3 months to seal the exterior.

74

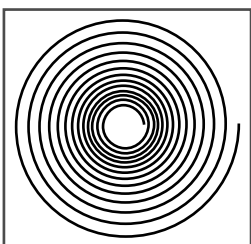

Apply the butyl tape along the outside side ridges of the roof. This will create a weather tight seal when the roof side flashings are fitted in the next step. Remove the protective paper from the butyl tape ready for fitting the side roof flashings.



75

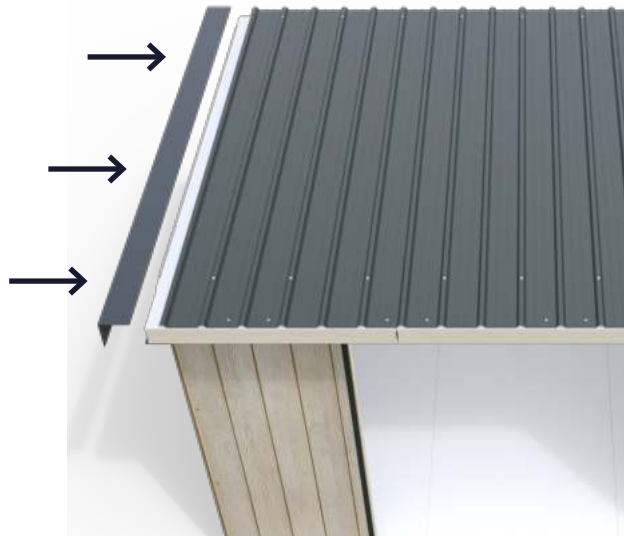

To fit the roof side flashings (SF-8) you should start with the left hand side, lifting it onto the roof whilst ensuring it is square to the front of building. You can check that the side flashing is in the correct position by looking underneath the hood of the roof to see that it lines up well with the black board fitted underneath as shown above.

76

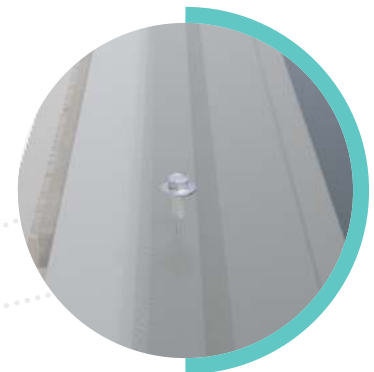
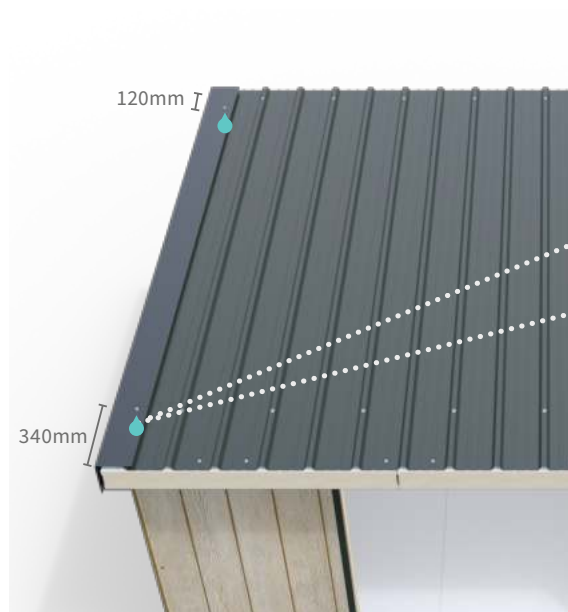

2x SC-3
Using Hex 5/16

To attach the side metal flashing, measure 340mm back from the front of the roof and screw a SC-3 stitching screw. Then measure 120mm forward from the back of the building and screw another SC-3 screw at this point.

Both of these screws should be positioned to go through the high ridge underneath the flashing - you will need to feel for where this is to ensure the proper position.



77

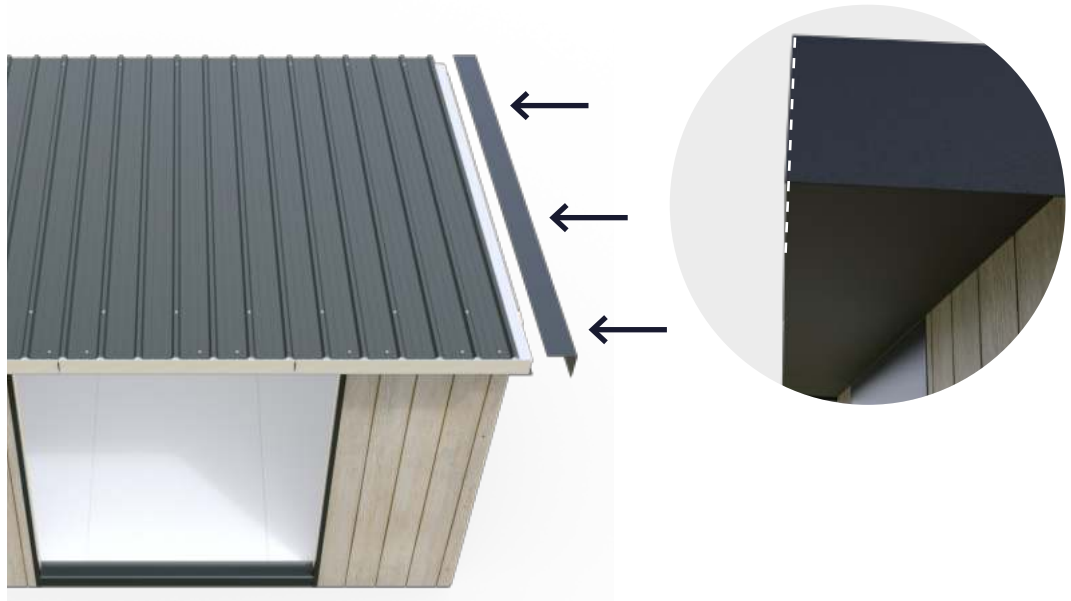

Now repeat on the right hand side of the building by lifting an SF-8 onto the roof, and checking again that it is level with the black board underneath the hood.

78

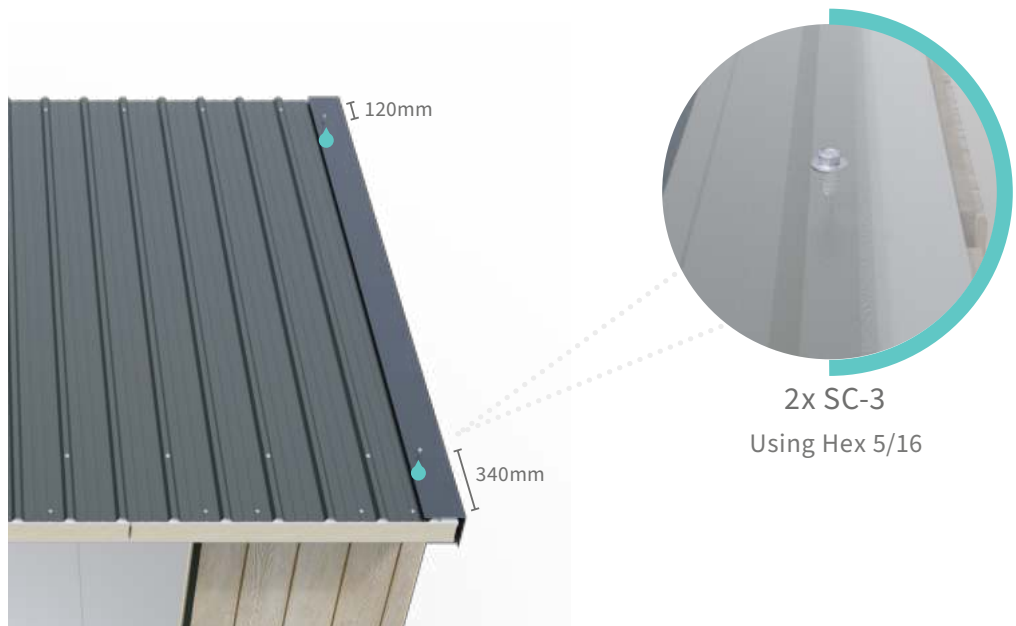

2x SC-3
Using Hex 5/16

To attach the right metal flashing, measure 340mm back from the front of the roof and screw a SC-3 stitching screw. Then measure 120mm forward from the back of the building and screw another SC-3 screw at this point.

Both of these screws should be positioned to go through the high ridge underneath the flashing - you will need to feel for where this is to ensure the proper position.



79

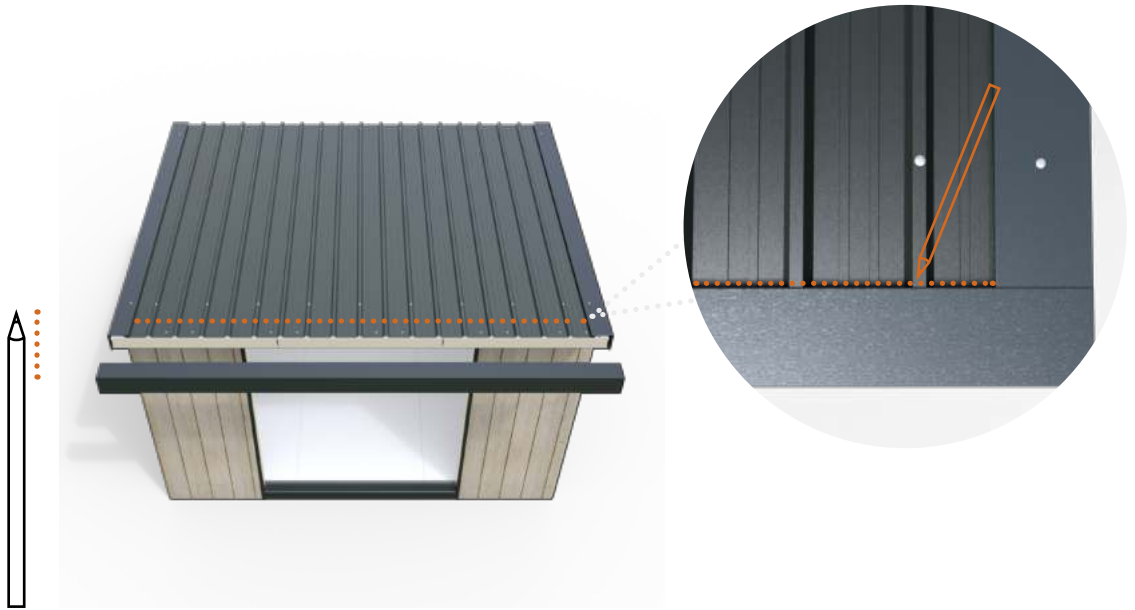

Pick up the front flashing (FF-12) and place it onto the front of the roof. Using the flashing as a guide, mark the roof across the point where the flashing ends with a pencil.

80

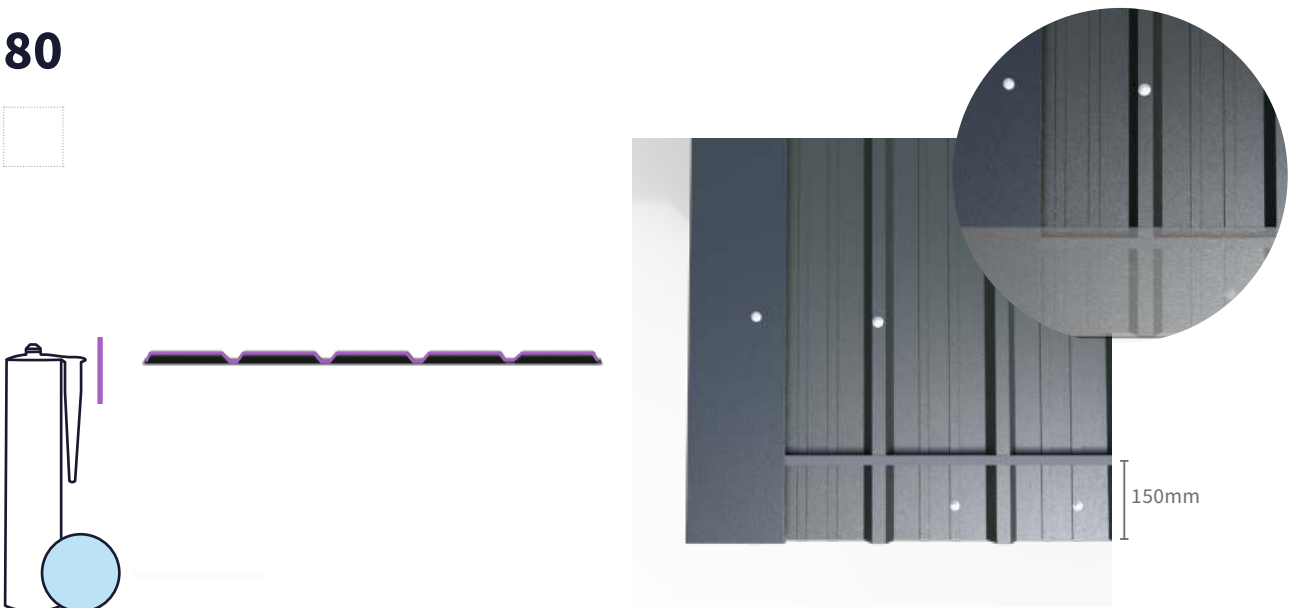

Apply clear silicone to the ridge filler along the grooved side, and then lay the ridge filler on the roof following the grooves, placing the ridge filler with the siliconed side facing down. Make sure that the ridge fillers is laid no more than 150mm back from the front of the roof using the guide line you've just created.

54



81

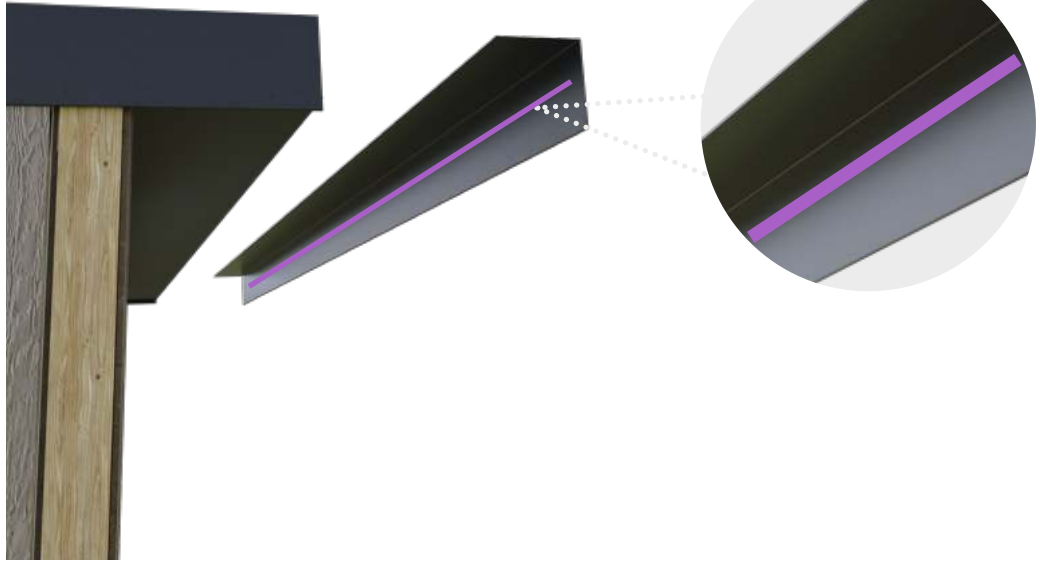

Apply clear silicone to the front facing inside edge of the front flashing. Make sure to apply the silicone at around 80mm from the central crease (the safe area is between 70mm - 100mm from the central crease).

82

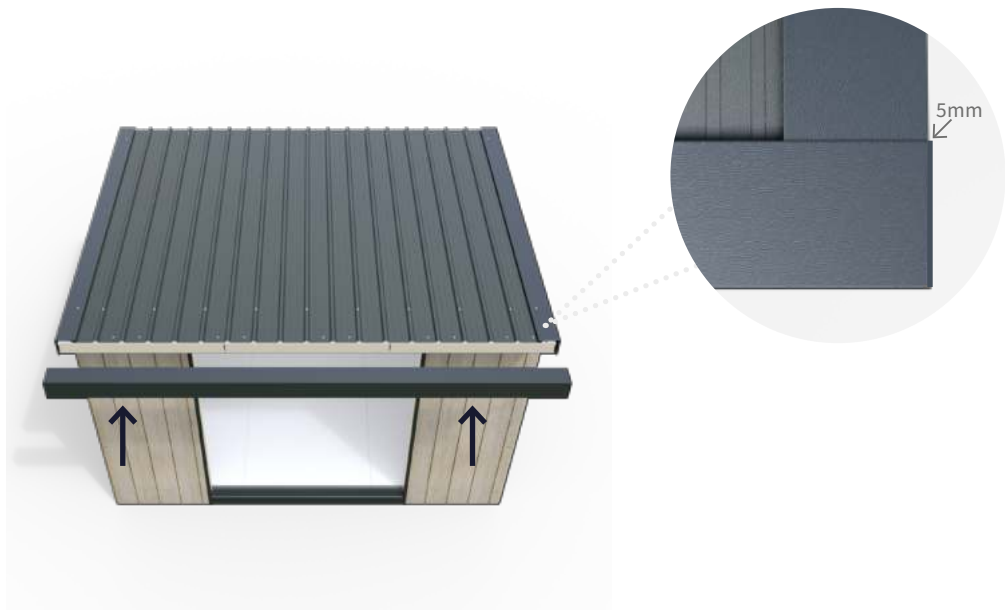

Place the front flashing (FF-12) onto the front of the roof, making sure that the siliconed inside edge sits on the front face of the roof. The front flashing should overlap the side roof flashing, and there should be an approx 5mm overhang on either side.



83



9x SC-3
Using Hex 5/16

Following the screw positions on the diagram above, start to screw the front flashing into the roof from the top, working from the middle outwards using 9x SC-3 screws. Make sure to screw into the ridges of the roof as to pinch the foam ridge filler between the roof and the flashing, approx 140mm from the front corner crease of the flashing.

84



3x SC-3
Using Hex 5/16

Use 3x SC-3 screws in the locations shown above to secure the left corner of the front flashing. These screws are located 25mm in and across from the corners shown.

Repeat on the right corner of the front flashing.



85

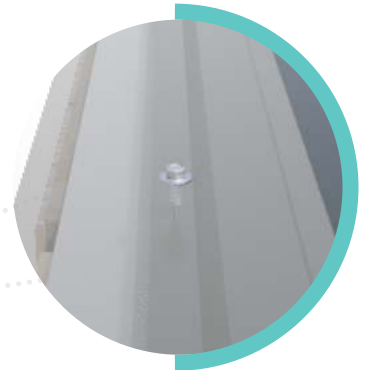
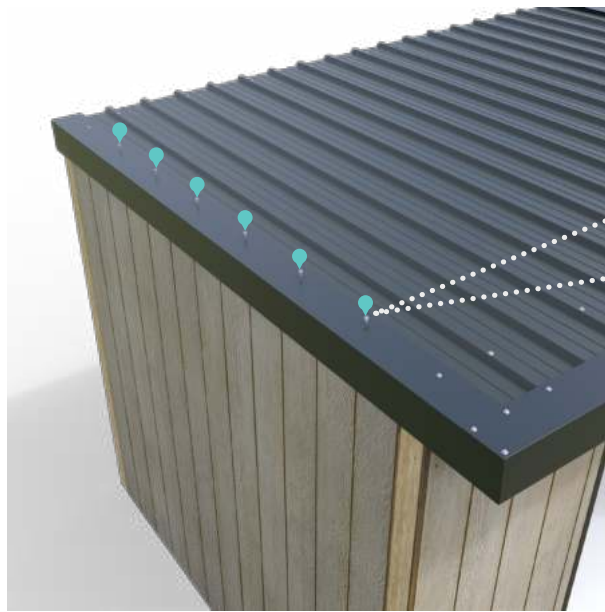

6x SC-3
Using Hex 5/16

Fix the left roof flashing in place using 6x SC-3 screws every 350mm from the front screws you have already installed.

86

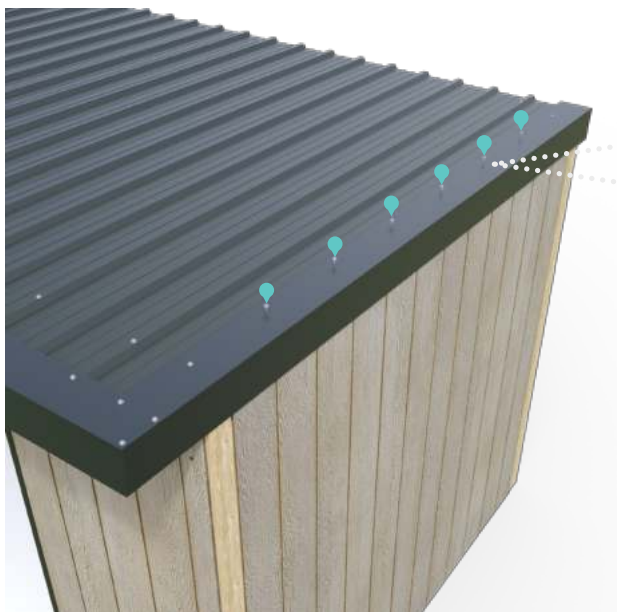

6x SC-3
Using Hex 5/16

Fix the right roof flashing in place using 6x SC-3 screws every 350mm from the front screws you have already installed.



87

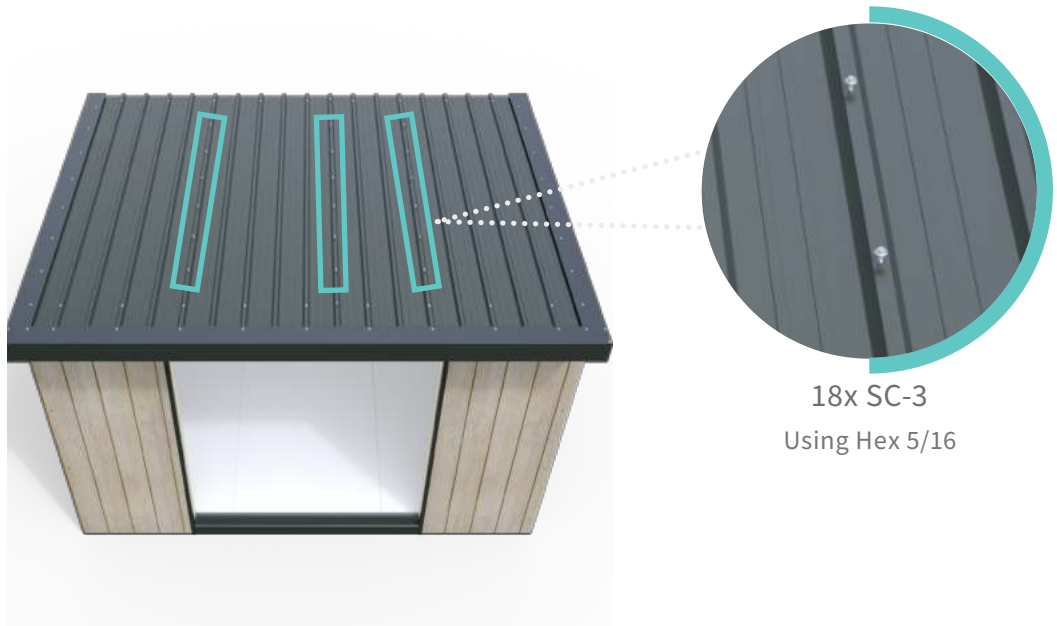

Secure the outer ridge of the overlapping central roof sheets using the same process. Fit 6x SC-3 screws along the ridge of the second, third and fourth roof sheet overlapping joins (18 x SC-3 screws in total). This step helps secure these panels against the wind.

88



Check the frame around the doors is level and upright with a spirit level ready for the doors to be installed. Check the flashing along the bottom first and then the uprights to the side of the doors. If it's not level check that you have 1830mm between the door uprights. You can then measure corner to corner to ensure they are equal. You may need to push the building from the sides to get it square.

58



89



Remove the keys from inside of the door frame; you will find the keys screwed into the inside of the indicated door panels. Use the keys to make sure the doors are unlocked.
 Unscrew the small protective corners at the bottom of the door frame, using PH2 long series bit.
 Unpeel the stickers that cover the doors on the inside base of the frame.
 Remove all protective films.

90

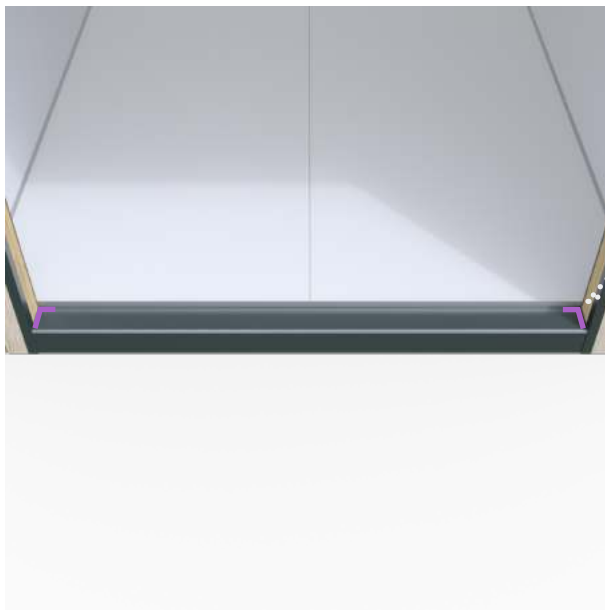

Silicone the top corners of the under door trim (UDT-6) in the locations shown above.
 This creates an L shape seal for the doors to sit in.
 Ensure that the 12mm upstand of the trim pushes against the upright metal base flashing.



91



With 2 people, lift the doors into place and make sure the inside of the doors are level with the inside of the wall panel. Ensure there is the same size gap between the edge of the door-set and the wall on each side. The rear face of the door needs to sit against the lip on the under door trim, which when pushed upright will make the inside frame sit flush with the interior white walls.

92



It is important that someone is always holding the doors into place until they are secure. Open the right hand door as viewed from the outside and open the window ready to be able to screw through the uPVC.

60



93



1x SC-5
Using PZ2 Extended

To initially secure the door in place, pilot a hole 250mm in from the top right hand side from the inside of the doors using the 5mm long series drill bit. Pilot the hole through the uPVC only, and not into the timber behind the door-set.

Then fit an SC-5 screw into the pilot hole and all the way through into the timber behind. For now, do not fully tighten this screw, leaving around 5mm of the screw exposed. All screws for the doors will be tightened at a later step.

94

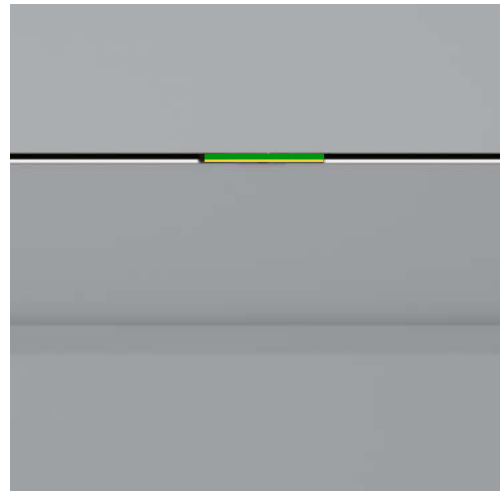
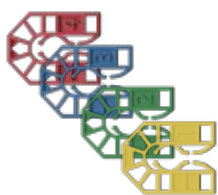

Follow this guidance every time you pack around a screw. Packing the doors is an important step to ensure the doors fit correctly and prevent breakage. The goal is to pack between the doors and the walls tightly to encourage the doors to sit completely straight from side to side, and from top to bottom. The doors should not be screwed into the walls where it would cause them to flex outwards, as creating a straight line with packers is essential. To pack the screw you've just fitted, choose from a combination of DP-1/2/3/4 door packers to push tightly into the gap between the door and the wall. When inserted, the door packer should hook over the screws you've fitted and be completely flush between the door and the wall without protruding.

Note: You may need to layer more than one packer on each side to tightly fill the gap. Use your glazing shovel or multi-knife to widen the gap and tightly insert as many packers as are needed.

- • • • • • • • • • • • • • • •
- • • • • • • • • • • • • • • •

95

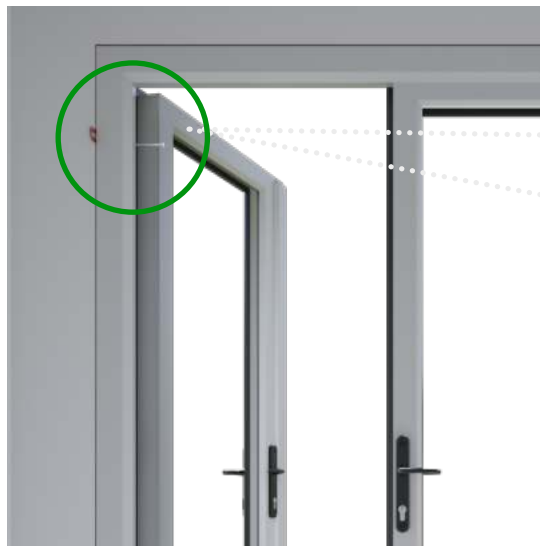
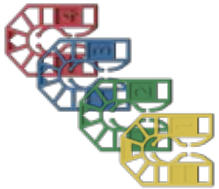

1x SC-5
Using PZ2 Extended

Measure 250mm from the top left hand corner of the door set.
 Pilot a hole at this location using the 5mm long series drill bit, again only drilling a hole through the uPVC and not into the timber behind.
 Fit 1x SC-5 through the pilot hole and through into the timber, and remember to not fully tighten the screw.
 Pack around the screw using a combination of DP-1/2/3/4 to pack tightly between the door and the wall, hooking over the screws you've just fitted.

96



1x SC-5
Using PZ2 Extended

Repeat as above at the top right hand side of the door set; drilling a hole, loosely fitting the screw and packing around the screw using a combination of door packers.

The door is now secured enough that it should not need to be held.



97

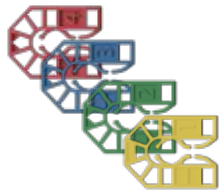

1x SC-5
Using PZ2 Extended

Measure 250mm up from the bottom left hand corner of the door set.
Pilot a hole at this location using the 5mm long series drill bit, again only drilling a hole through the uPVC and not into the timber behind.
Fit 1x SC-5 through the pilot hole and through into the timber, and remember to not fully tighten the screw.
Pack around the screw using a combination of door packers.

98

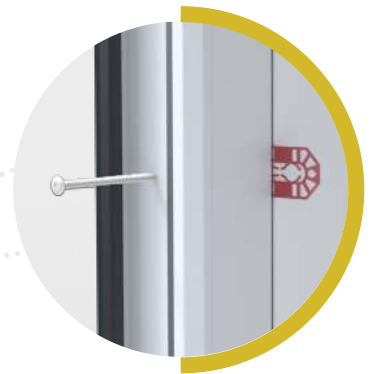
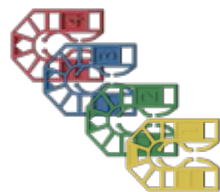

1x SC-5
Using PH2

Measure 250mm up from the bottom right hand corner of the door set.
Pilot a hole at this location using the 5mm long series drill bit, again only drilling a hole through the uPVC and not into the timber behind.
Fit 1x SC-5 through the pilot hole and through into the timber, and remember to not fully tighten the screw.
Pack around the screw using a combination of door packers.



99

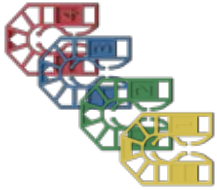

2x SC-5
Using PH2

Inside the building on the right hand side of the doors, measure 500mm below the screw you have fitted in the top corner, and fit 1x SC-5 screw in this location. Fit the screw but without tightening it for now, leaving 5mm of the screw exposed.
Repeat by fitting a screw 500mm above the screw you have fitted in the bottom right hand corner. Select from a combination of DP-1/2/3/4 to pack tightly between the door and the wall, hooking over the screws you've just fitted.

100

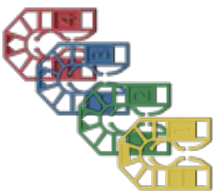

1x SC-5
Using PH2

Inside the building on the left hand side of the doors, measure 500mm below the screw you have fitted in the top corner, and fit 1x SC-5 screw in this location. Fit the screw but without tightening it for now, leaving 5mm of the screw exposed.
Repeat by fitting a screw 500mm above the screw you have fitted in the bottom right hand corner. Select from a combination of DP-1/2/3/4 to pack tightly between the door and the wall, hooking over the screws you've just fitted.



101

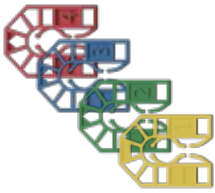

4x SC-5
Using PH2

Repeat this process to secure the top of the doors:
Measure 250mm from the top left and top right hand corner of the open door. At each location pilot a hole, fit a SC-5 screw without tightening and hook door packers over the screws to securely pack.
Repeat again at 100mm on either side of the central locking block.

102



1x SC-5
Using PH2

Measure 100mm in from the top right hand corner of the open top window. Pilot a hole, fit an SC-5 screw without tightening and hook door packers over the screw to tightly pack.



103

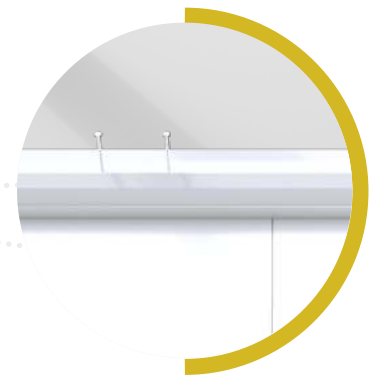
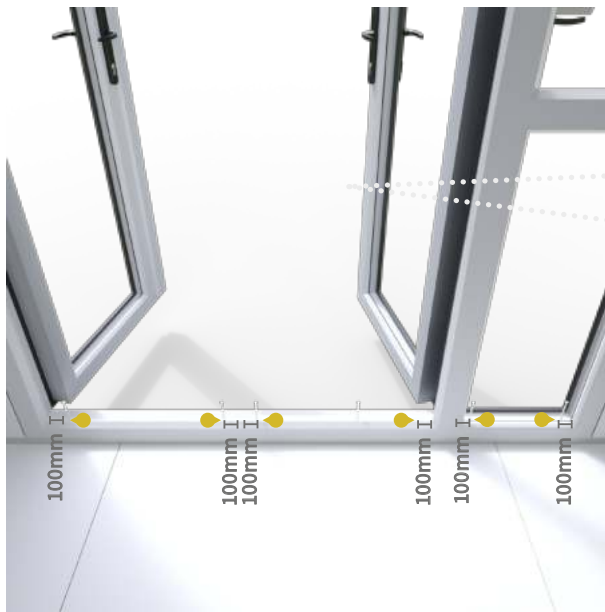

6x SC-5
Using PH2

To secure the base of the doors is a slightly different process. Measure 100mm in from the left and right corners of both the doors and the windows and pilot a hole through the frame of the doors only, and not into the timber behind. Fill the piloted holes with clear silicone to create a water barrier, then fit an SC-5 screw without overtightening. Repeat in the centre of the doors, 100mm either side of the central locking block.

104



Now secure the doors to the timber frame by **tightening all of the screws**, including the screws in the door and window sections of your doorset.

Do not use an impact driver to tighten the screws as this could cause the frame to crack.



105

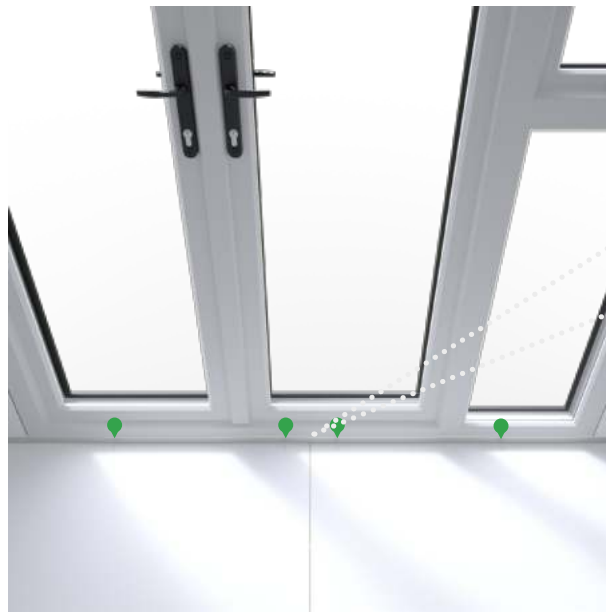

4x SC-1

You can now close your doors and windows. On the inside of the building, locate the base trim that sits underneath the doors. There will be 6 punched holes on this trim to indicate where to fit the screws. Use 4x SC-1 screws to pull the base flashing tight towards the doors.

106

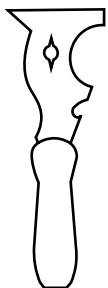

You are now going to start installing the glazing for the windows.

Remove the beading from the inside of the bottom fixed panel window, using your multi-knife to wedge between the beading and the frame to pop it free. Start by removing the vertical longer beading and then remove the shorter horizontal beading.

Note: If the weather is cold, we recommend keeping the beading stored in warm soapy water.



107



Remove the beading from the inside of the top opening window using the same process as above.

108

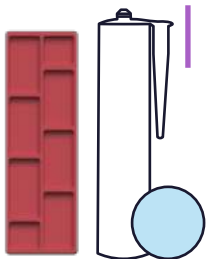

Starting with the bottom window, apply a small amount of silicone in the locations shown above (indicated by the red window packer) and then push a red window packer WP-6 onto the silicone dots. Approximate measurements for the locations of the silicone and packers are 100mm from either corner at the bottom of the window, and 250mm from either corner on the sides of the window.



109



Make sure that the sticker on the glass is facing inside the building (read the sticker to confirm the glass is facing the correct way). Keep the black tape around the edge of the glass in place, and remove the sticky blue pads.

Fit the glass into the gap and on top of the packers.

110

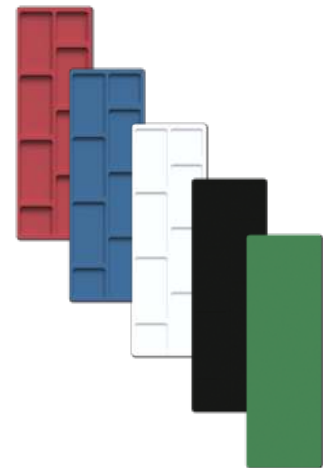
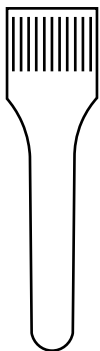

Slide 2 x WP-6 red window packers above the glass to pack it tight at the top.

If the glass seems loose inside the window gap, fit additional window packers around all sides until it is tight within the frame. You may need to use a combination of different colours and widths to get the best fit. Use the glazing shovel to create more space between the glass and frame if needed.



111

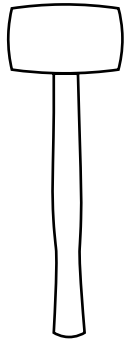

Top and Bottom Beads First:

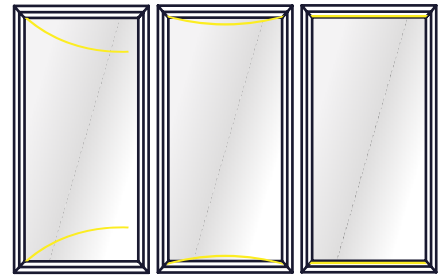

Vertical Beads Second:

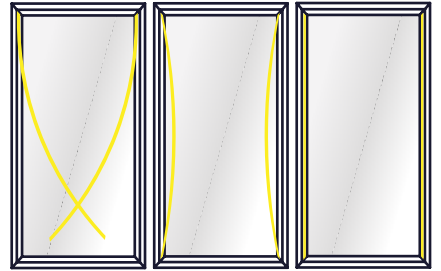

Once you are happy that your window glass is tightly in place, replace the beading. Start with the top and bottom beads, then finally replace the vertical beading using the technique shown in the illustration above.

Technique: The beads need to be fitted in each corner first, causing the centre to bow, and then use the rubber mallet to knock the middle of the beads straight in the centre.

112

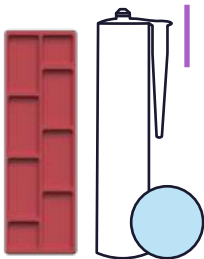

Now repeat the process for the top window.

Apply a small amount of silicone in the locations shown above (indicated by the red window packer) and then push a WP-6 red window packer onto the silicone dots.

Approximate measurements for the locations of the silicone and packers are 100mm from either corner at the bottom of the window, and 250mm from either corner on the sides of the window.



113



Make sure that the sticker on the glass is facing inside the building (read the sticker to confirm the glass is facing the correct way). Keep the black tape around the edge of the glass in place, and remove the sticky blue pads.

Fit the glass into the gap and on top of the packers.

114

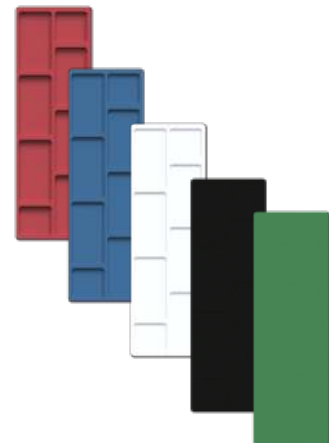
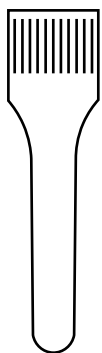

Slide 1 x WP-6 red window packer above the glass to pack it tight at the top.

If the glass seems loose inside the window gap, fit additional window packers around all sides until it is tight within the frame. You may need to use a combination of different colours and widths to get the best fit. Use the glazing shovel to create more space between the glass and frame if needed.



115

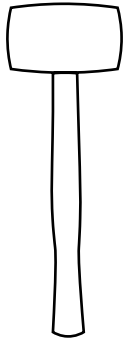

Top and Bottom Beads First:

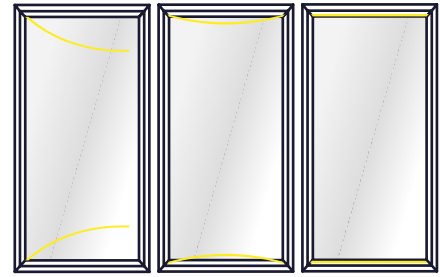

Vertical Beads Second:

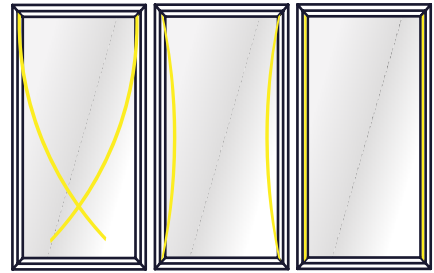

Once you are happy that your window glass is tightly in place, replace the beading. Start with the top and bottom beads, then finally replace the vertical beading using the technique shown in the illustration above.

Technique: The beads need to be fitted in each corner first, causing the centre to bow, and then use the rubber mallet to knock the middle of the beads straight in the centre.

116

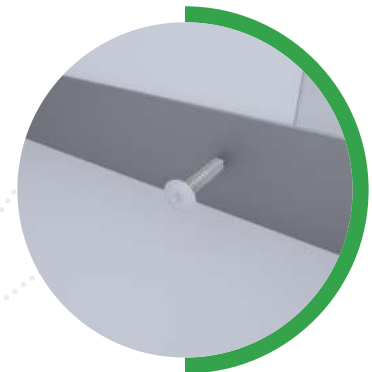

2x SC-1
Using PZ1

Inside the building, locate the metal base flashing near the door exit. Measure 20mm out from the door frame on each side and using 2x SC-1 screws, fit one screw on each side of the doors to attach the base flashing to the vertical timber framing the doors in the panels FL-9 and FR-9.



117

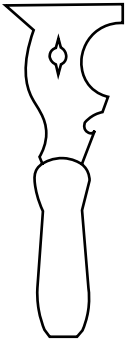

You are now going to start installing the glazing for the doors, starting with the right hand door as viewed from the inside.

Remove the beading from the inside of the doors using the multi-knife. Start by removing the vertical longer beading and then remove the shorter horizontal beading.

Note: If the weather is cold, we recommend keeping the beading stored in warm soapy water.

118



In the top left hand corner of the window opening of the right hand door, measure 80mm along from the corner and 80mm down from the corner. Fit a WP-6 red window packer at each 80mm location by applying a drop of clear silicone and placing the packer on top.

Repeat on the bottom right hand corner of the door opening. You will use 4 red packers in total for this step.



119

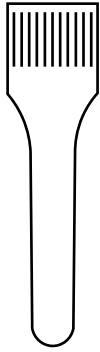

Make sure that the sticker on the glass is facing inside the building (read the sticker to confirm the glass is facing the correct way). Keep the black tape around the edge of the glass in place, and remove the sticky blue pads.

Fit the glass into the gap and on top of the packers.

120

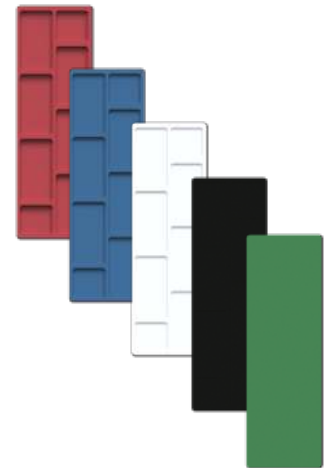
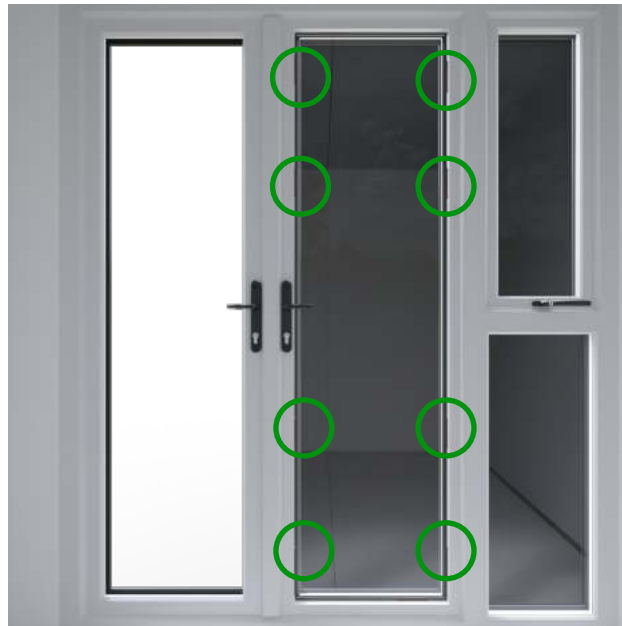
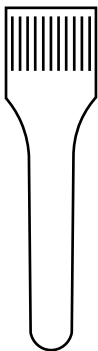

Insert a combination of window packers WP-1/2/3/5/6 to the sides of the glass to make it sit centrally in the frame. Use the glazing shovel to widen the gap if needed.



121

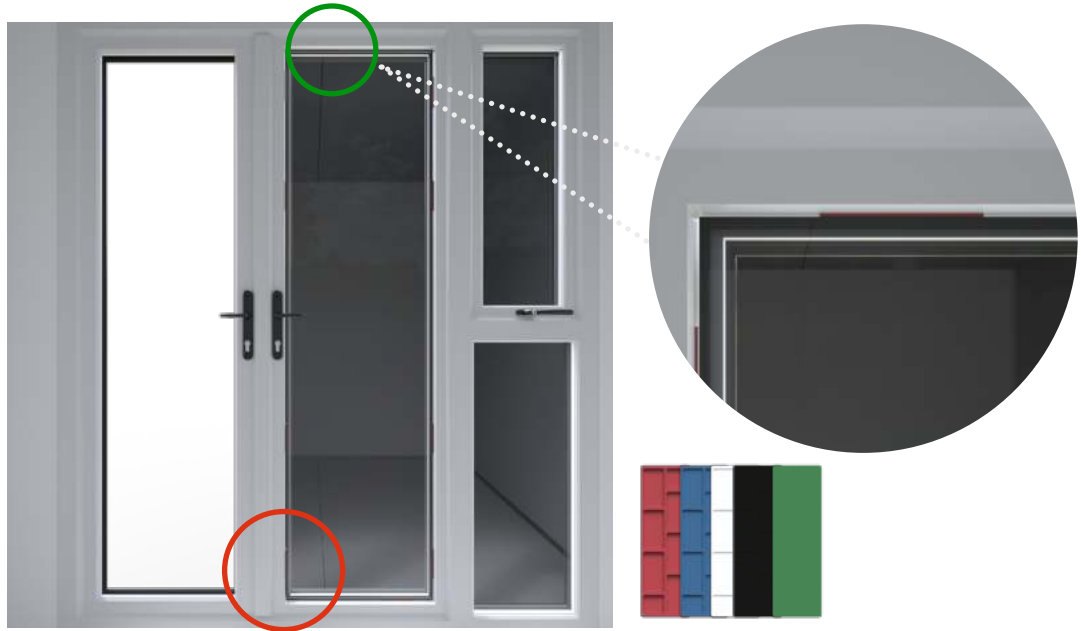
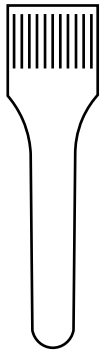

If the bottom corner of the door scrapes the frame at the bottom (location indicated by the red circle), then you will need to add more window packers at the top of the doors in the location shown by the green circle.

122

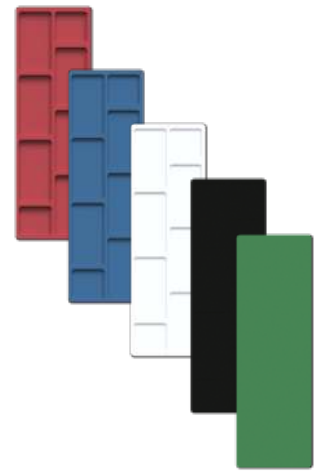
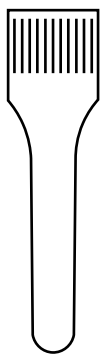

Measure from the top of the door sash to the top of the glass on each side to check how balanced the glass is sitting. If this measures as parallel then no adjustments are required. If the measurements are not parallel then the adjustments that you will make on the next steps will cause the doors to sit more level and ensure that they close properly.



123



Check that the door closes without catching at the top or bottom of the frame. You can also check that the door is sitting square by measuring from the top of the door sash to the door head.

Continue to make adjustments until you are happy with the closure fit.

124

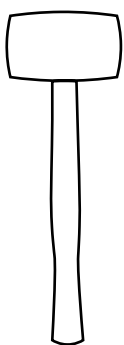

Top Beads First:

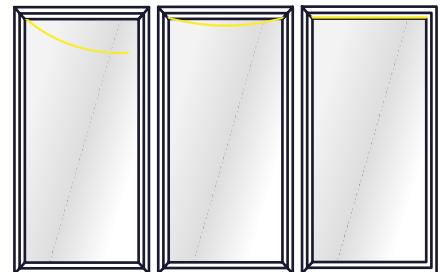

Bottom Beads Second:

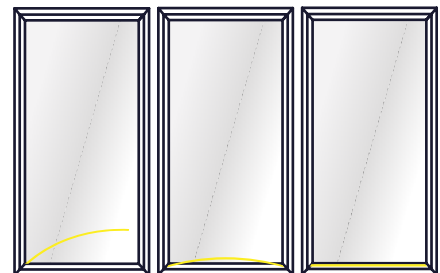

Now replace the top beading flexing it as shown in the diagram above. Start by fixing one corner of the beading, then flex the beading to fit the other end into the corner and then push the centre of the beading down towards the frame. Use the rubber mallet to gently tap it into the frame. Repeat with the bottom beading.



125

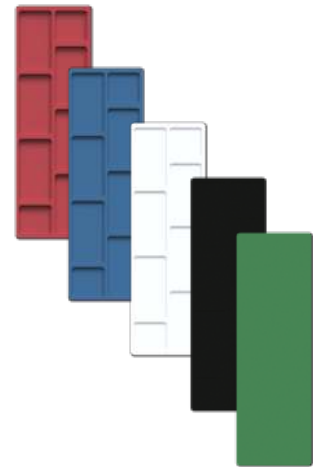

If required, insert a combination of window packers WP-1/2/3/5/6 to the side of the glass nearest to the door handle to make sure this section of the glass is tightly packed. Use the glazing shovel to widen the gap if needed. The sash of the door should be parallel.

126

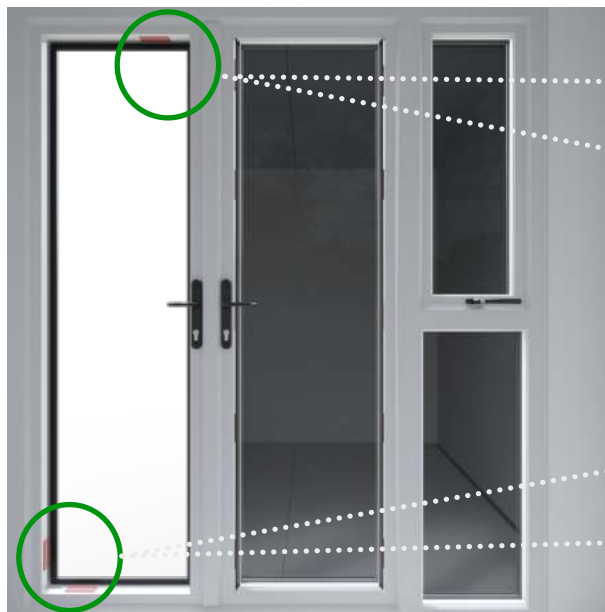

Now repeat with the left hand door.

Remove the beading using the multi-knife. Insert 2 WP-6 red window packers in each of the two locations shown above, remembering to fit them with a drop of clear silicone.



127

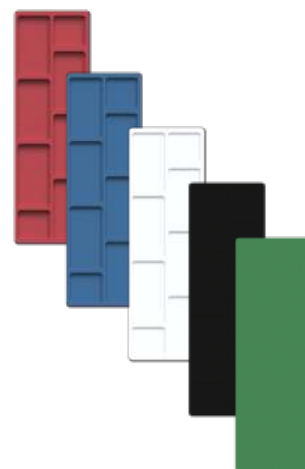
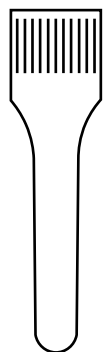

Insert the glass into the frame, making sure that the glass is facing the correct direction (see glass sticker for details).

Insert a combination of window packers red/2/3/5/6 to the sides of the glass to make it sit centrally in the frame. Use the glazing shovel to widen the gap if needed.

128



Adjust as before, adding window packers at the top of the glass to encourage the door to sit straight within the frame.



129

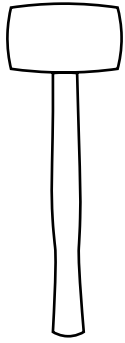

Top Beads First:

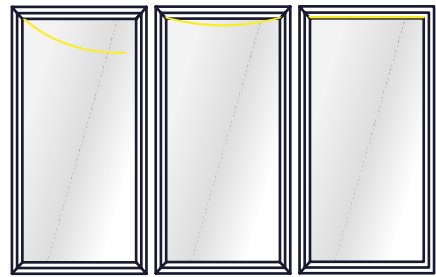

Bottom Beads Second:

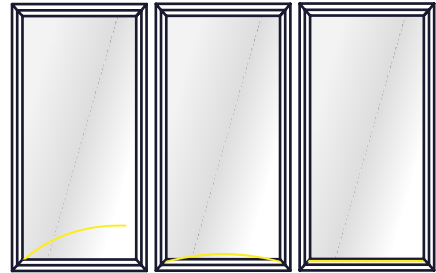

Replace the top and bottom beading as before, again leaving the side vertical beading off for now.

130



The central gap between the doors from the front of the building should be consistently between 20-22mm from top to bottom. This allows for expansion and contraction through the seasons.

If adjustments are still needed at this stage you can add more window packers from the inside of the building to the side of the glass.



131

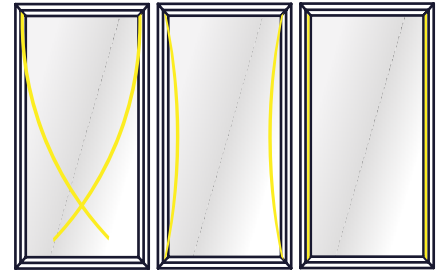
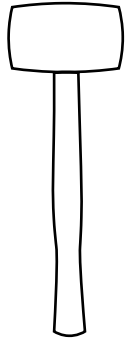

Now that your doors are level you can replace the side vertical beading on both doors.

132



Remove all stickers and protective films from the door and window frames.
Clip the trickle vents into the inside and outside of the doors.



133



Clip the drainage caps into the gaps on the outside of the doorset.

134

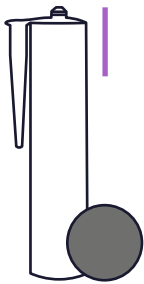

Using the anthracite silicone, apply a thin bead around the doors in the position shown above.



135



Collect the 4 corner trims from your pack and lay them near the correct corner ready for fitting at each location.

136



Note: When fitting the corner metal flashings, be sure to place the section of the corner that measures 93mm on the front face (or back face) of the building, and the wider section on the side face of the building. If you have painted your building already, you can also add a bead of clear silicone underneath each corner for added security. If you are painting your building later, you might want to leave the silicone for now so that you can remove the corner metal flashing for a neater finish on the paint.



137

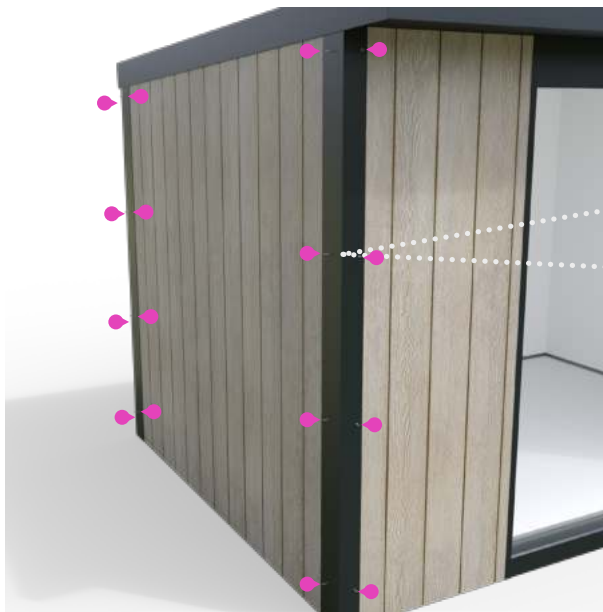

32x SC-6
Using PZ1

On each face of the corner metal flashing you will find 4 punched holes running from top to bottom. Fit 4x SC-6 screws through the punched holes on each face of the corner metal flashings, using 8 screws per corner in total. Repeat on all 4 corners, using 8 screws in each corner and 32 screws in total.

138



Gently lift the side of the metal roof flashing away from the building to apply a bead (line) of silicone to only where the building and the flashing will meet. Repeat this step on the left and right hand side of the building. Press the flashing tightly to the side of the building for it to become secured. This step helps secure the side flashing from wind damage.



139

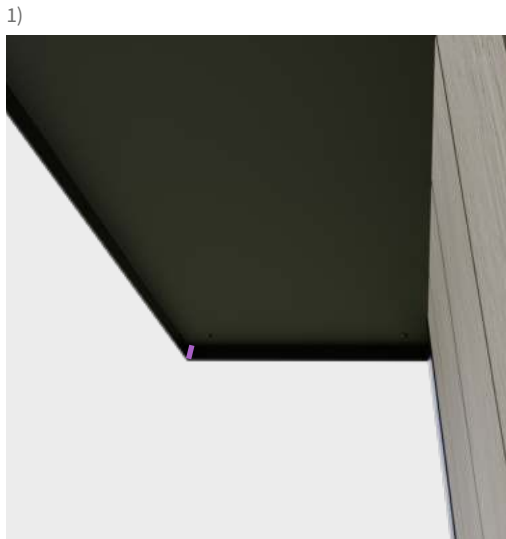
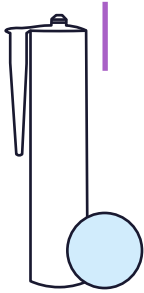

Using the clear silicone, apply a bead to the inside corner join of the roof flashings on the hood of the building. Be sure to repeat this step in both inside front corners.

Repeat on both outside corner joins.

140

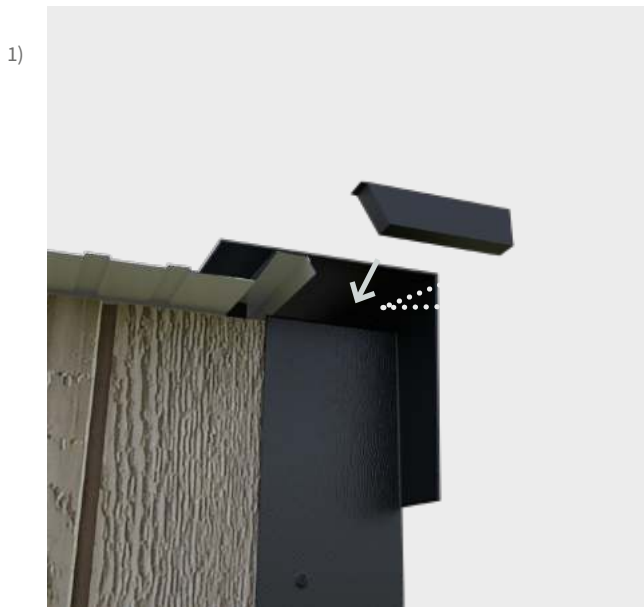

Cut a spare piece of foam ridge filler and insert it into the gap that the side flashing creates over the roof sheets. Repeat this step on both sides of the building.



141

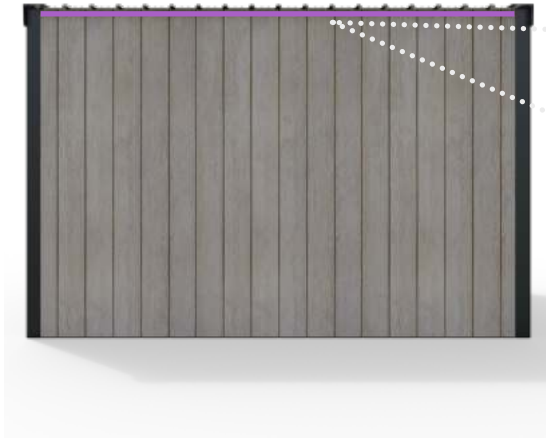

Apply a bead of clear silicone along the top edge of the building, where the roof sheets meet the back wall panels.

142

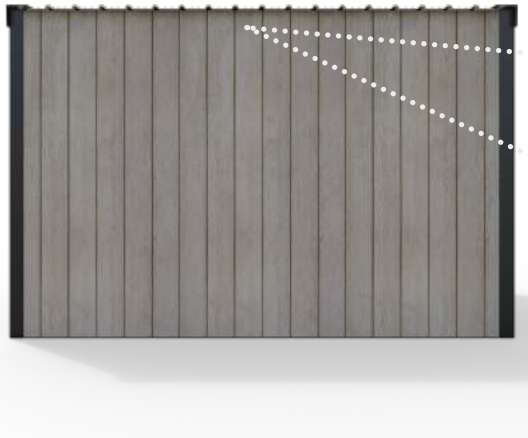

Locate the centre line of the back of the building, and use a pencil to mark a small line 30mm down from the top of the cladding.



143



Left)

Right)

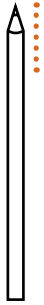

At either side of the building, mark a pencil line 5mm down and 50mm in from the corner flashing. The lines you have drawn help guide where you screw the clips in the next steps.

144



1)



2)



Complete:



Connect the guttering T-pipe, downpipe and downpipe end.

Note: Check that the rubber seals are in place as you snap the parts together.



145

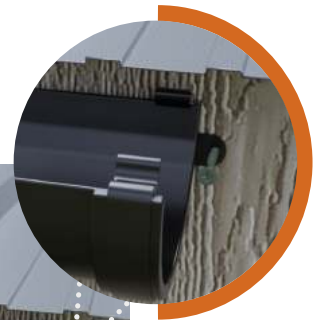
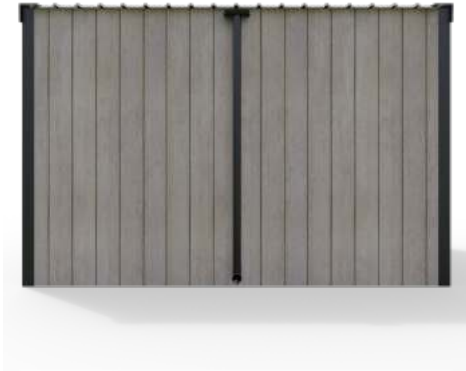

2x SC-7
Using PZ2

Align the T-pipe below the line you marked previously in the centre of the building. If you're happy with the length of the downpipe then secure it in place using 2x SC-7 screws, fixing one screw to either side of the T-pipe bracket.

If the downpipe needs to be shortened, use your saw to remove length from the downpipe. Check that the rubber seals are in place on either side of the T-pipe bracket.

146



Remove the downpipe end piece and apply clear silicone to the joint, and then reattach to the downpipe.



147



1)

2)

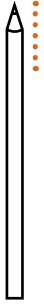

Now place your long spirit level flat in the gutter and align it with the line you've previously marked at the top left of the building. Mark another line with your pencil, exactly halfway between the two existing lines. The 3 lines you've drawn should mark a slight slope from the edge of the building inwards, which allows rainwater from your roof to flow to the downpipe.

148



1)

2)

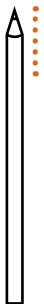

Again, use your long spirit level to mark another line halfway between the centre line, and the line you marked on the top right of the building.



149

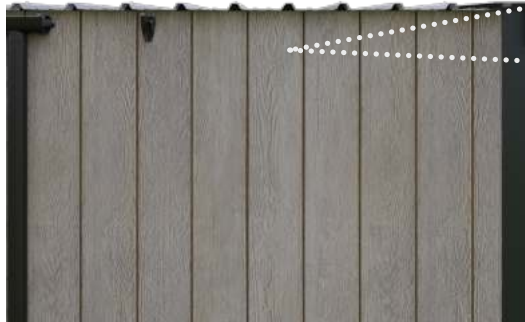

2x SC-7
Using PZ2

Take a u-shaped gutter bracket and align it just under the line you created on the centre-right of the building, and fix it to the cladding using 2x SC-7 screws.

150



2x SC-7
Using PZ2

Now attach another u-shaped gutter bracket to the top right of the building, again making sure to align the top just under the pencil mark you created previously. Affix the bracket using 2x SC-7 screws.



151



Before:

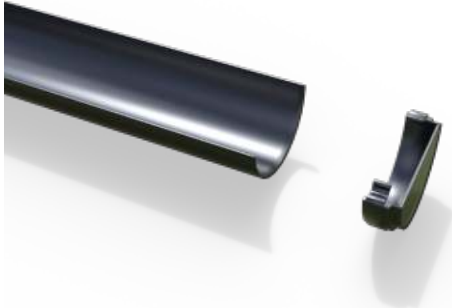

After:



Attach a u-shaped gutter stop to the right hand side end of one of your u-shaped gutter lengths. It should snap on when its correctly attached.

Note: Check that the rubber seal is in place as you snap the parts together.

152



Place this completed u-shaped guttering length onto the right hand side of the building, laying it onto the T-Pipe and the brackets you've installed. Push the back of the pipe into the brackets first, then snap the front of the brackets onto the pipe. You should hear a snap when it's correctly attached.



153



2x SC-7
Using PZ2

Now move onto the left side of the building.

Align the top of both remaining brackets with the marks you created earlier. The bracket on the far left should sit the highest, with the bracket to the right of that slightly lower. Screw these two brackets in with 2x SC-7 screws on each bracket.

154



Before:

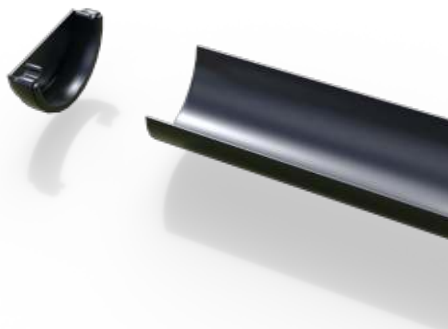

After:



Attach your remaining u-shaped gutter stop end piece to the left hand end of the remaining u-shaped guttering length. Again snapping it on tightly.

Note: Check that the rubber seal is in place as you snap the parts together.



155



Place your final guttering length onto the left side of the building, laying it down into the T-Pipe and brackets. Push the back of the pipe into the bracket first, then snapping the bracket onto the pipe. Again, you should hear a snap when it's fitted correctly.

156



Measure 700mm up from the bottom of the building, and place a downpipe bracket over the downpipe at that location.



157



Measure 1400mm up from the bottom of the building and place other downpipe bracket over the downpipe at that location.

158

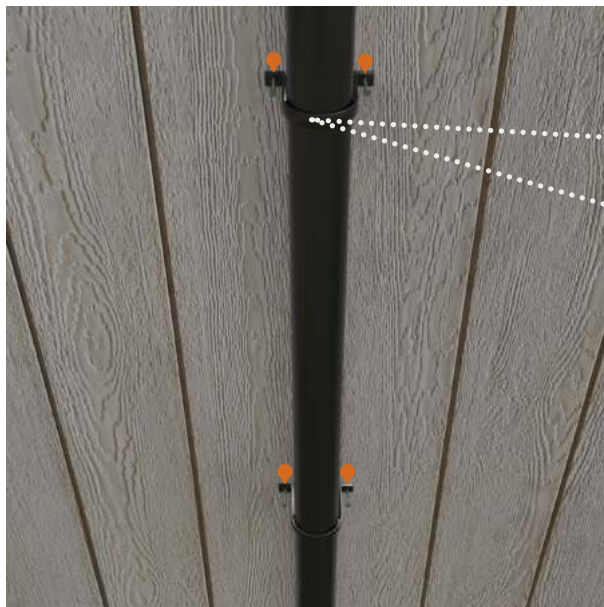

4x SC-7
Using PZ2

Check that the downpipe is dropping straight vertically before fixing it to the building by comparing it to a ridge of the cladding.

When straight use 2x SC-7 screws in each bracket to secure it to the building.





Top Tip: Whether you've purchased our Flooring Pack, or you have sourced your own flooring - now is the perfect time to fit it. By laying your floor now you can ensure that the interior wall trims finish neatly at the top of your skirting boards.

159



Dust and wipe down the inside of the building. This will ensure that the finishing tape will stick to the walls and ceiling properly. Be careful not to use any chemicals to clean the building at this point, as this could cause the adhesives to not stick.



160

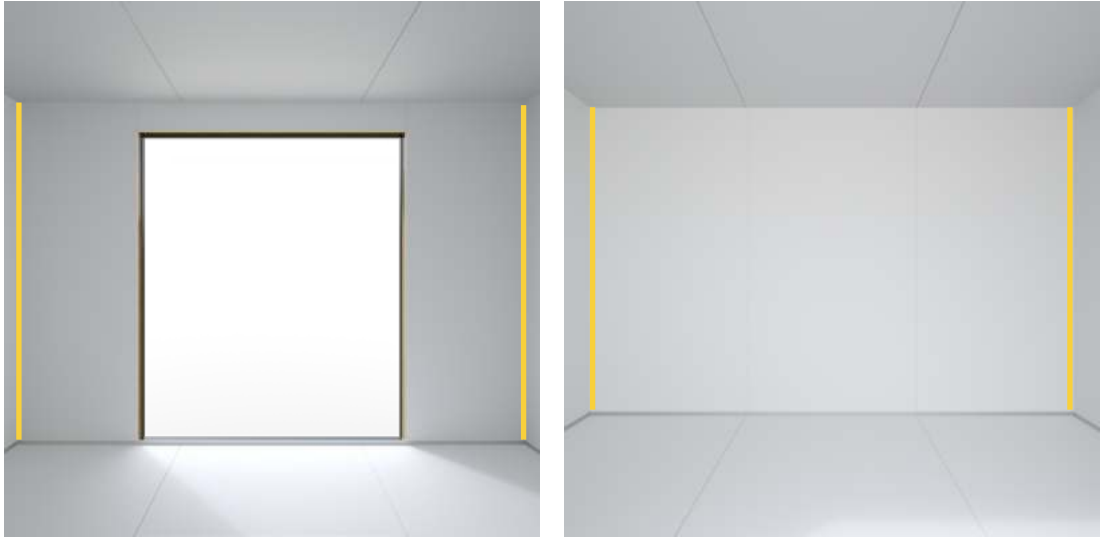

The first step to trimming the inside of the building is to start at the corners, which are highlighted above.

161

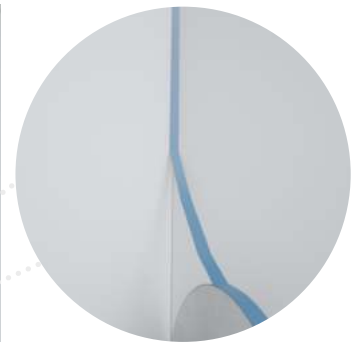
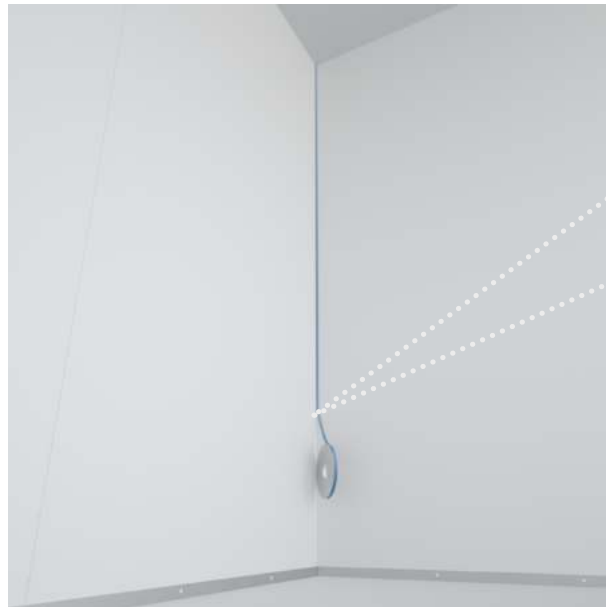
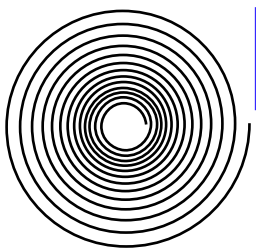

Carefully apply the double-sided tape over the gap between the walls in each corner of the building, taking care to hide the join between both walls with one long piece of tape.



162

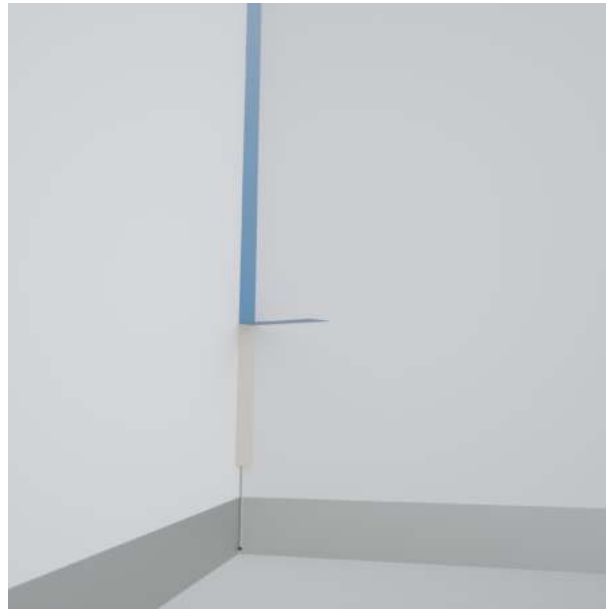

Cut the tape at the bottom just before you reach the skirting, and peel off the protective top layer of the tape.

163



Attach the corner trim by pressing it against the tape from top to bottom.



164

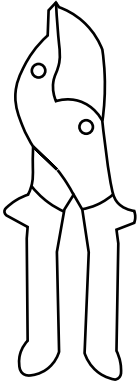

The trims come quite long, so using the mitre shears make a rough cut to trim it down to a more manageable size.

165



Now mark a more accurate cut with a pencil and cut it with the mitre shears to ensure it fills the vertical space. The cut lengths could vary depending on your chosen floor thickness.



166

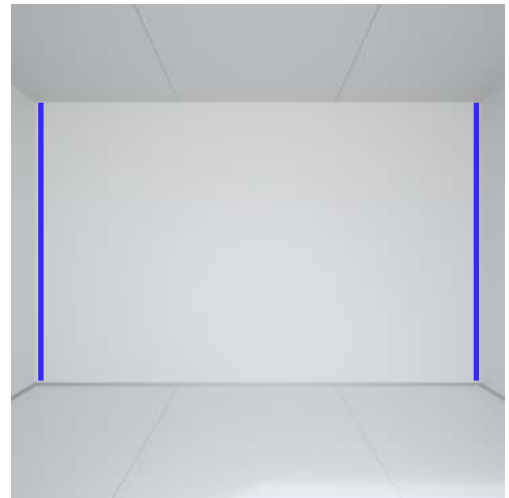
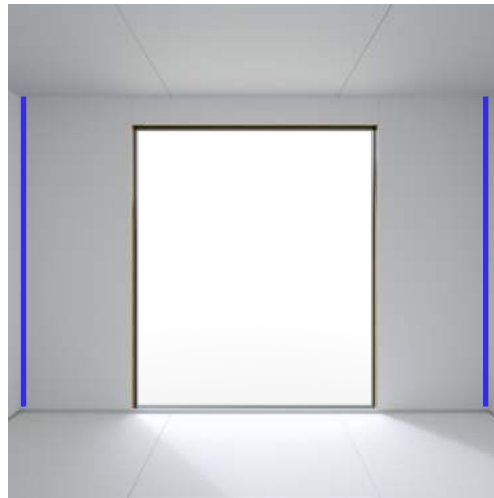
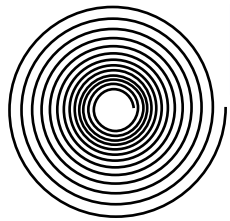

Repeat these steps on all 4 corners, using the double-sided taped, corner trim and mitre shears.

167

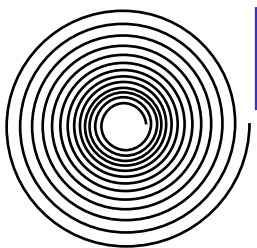

Measure 10mm below the ceiling, and apply the double-sided tape horizontally across the back wall at this location. This will mean that the tape is running 10mm below the join of the ceiling and the wall. Trim the tape to cover the full width of the wall.



168

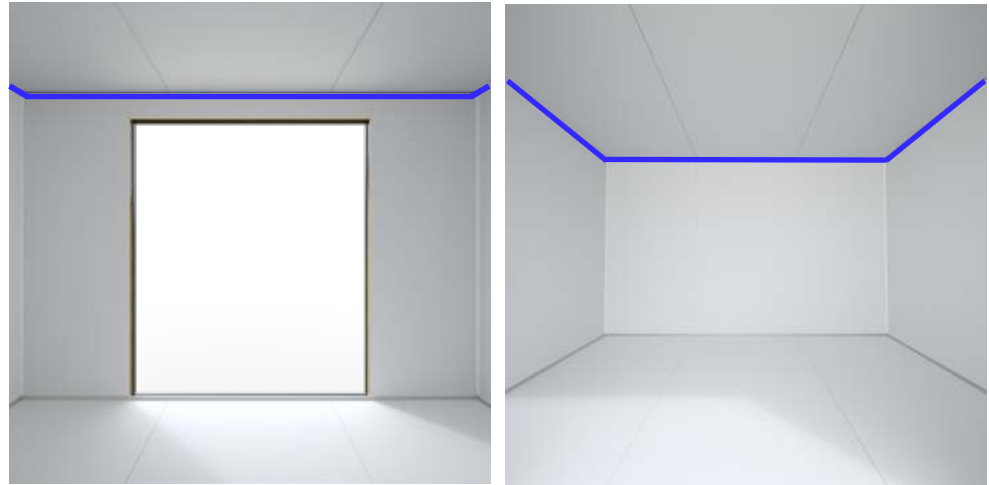
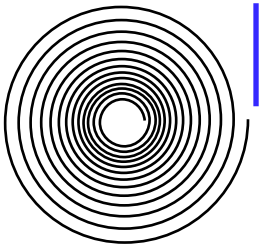

Repeat this step for all 4 walls using the double-sided tape.



169

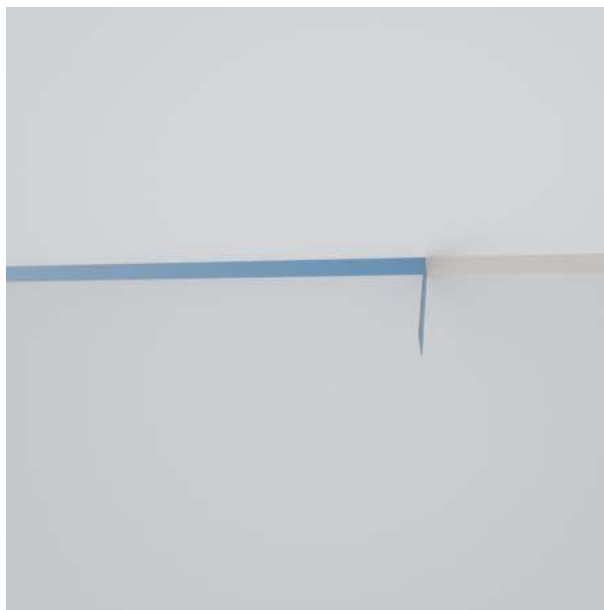

Remove the protective layer from all the tape only when you are ready to apply the ceiling trim.



170



Place the ceiling trim along the top of the back wall, ensuring it sits snug to the ceiling and over the tape you applied in the previous step. Be sure to place the ceiling trim with the curved side facing down against the building.

171

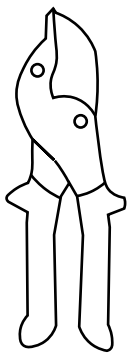

The trim will be longer than you need, so cut it down to size as you did with the corner trim using the mitre shears.

100



172



Repeat this step for all 4 walls using the ceiling trim and the mitre shears. Be sure to place the ceiling trim with the curved side facing down against the building.

173

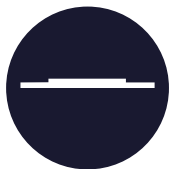

The wall trim comes with double-sided tape pre-fitted to the back. Take a strip of the wall trim ready to fit to the back wall, and remove the protective layer.



174

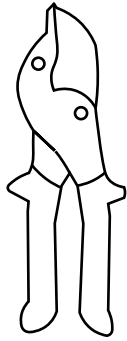

Place the wall trim horizontally against the centre of the back wall. The trim will be slightly too long, so incrementally make small cuts to remove the excess as before with the mitre shears, using a pencil to accurately mark the final cut.

175



Inside Left Wall:

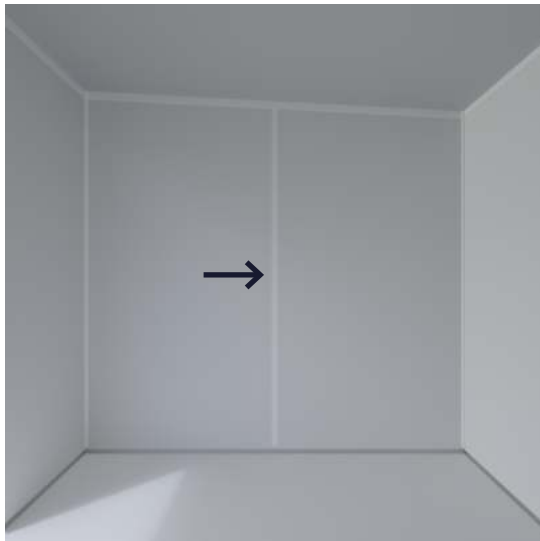

Inside Right Wall:

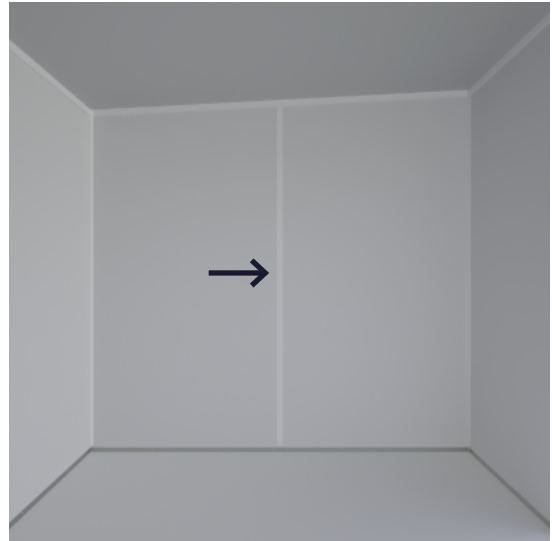

Repeat this process on the join of the left and right walls.



176



Run a strip of wall trim vertically on either side of the door frame, cutting down to size as before.

177



Finish the door by running a strip of wall trim vertically above the door frame, between the two vertical strips you just installed.



178

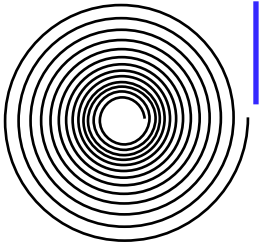

To trim along the gap in the centre of the ceiling, apply double-sided tape, remove the protective layer.

179



Run a strip of ceiling trim along the entire length of the roof panel. Use the mitre shears to carefully trim down to size. Be sure to place the ceiling trim with the curved side facing down against the building.

104



180



Inside Front Wall:



Inside Back Wall:

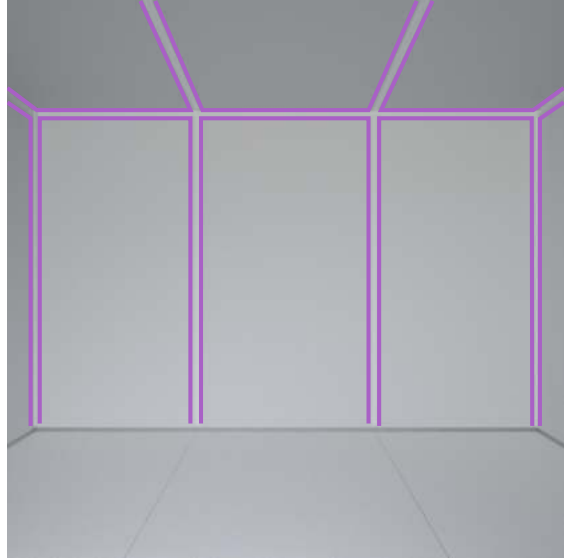

Inside Left Wall:

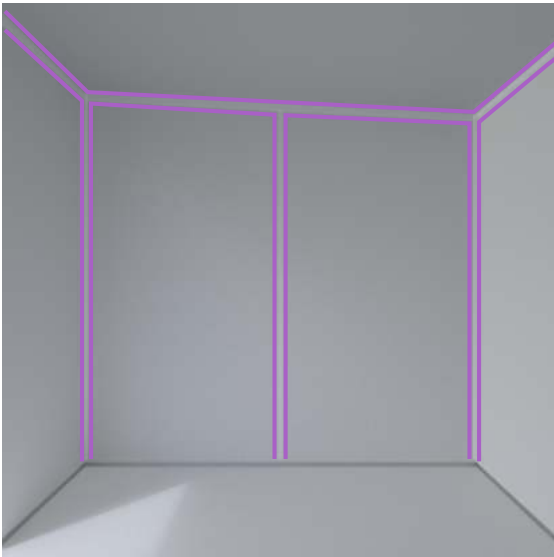

Inside Right Wall:

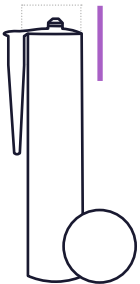
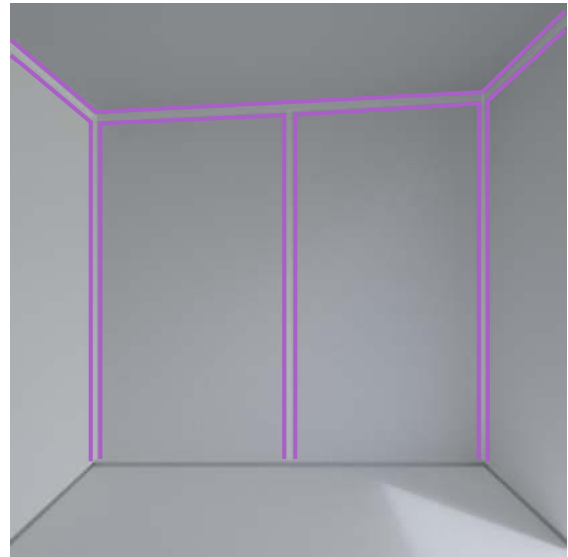

Now you will use white silicone to seal all the gaps left during the trimming process. Please refer to the diagrams to see exactly where to apply the silicone.

You will want to apply a thin bead of silicone to seal every edge of the trims along the walls and ceiling of your building. Hold your silicone at a 45degree angle to the wall and pull down or along to apply the silicone (do not push the silicone when applying).

Using a solution of water and washing-up liquid, dip your finger into the solution and then run your finger along the silicone to create a smooth clean finish.



FINISH.

**The building
is now fully
installed.**