



VERTICAL FILE CABINET

SAFETY & WARNINGS

Warning

- Check you have all the components and tools listed on pages 3-5.
- Remove all fittings from the plastic bags and separate them into their groups.
- During assembly children should be kept away from the product due to possible risk of injury.
- Make sure you have enough space to layout the parts before starting.
- Do not stand or put weight on the product, this could cause damage. Assemble the item as close to its final position (in the same room) as possible.
- Assemble on a soft level surface to avoid damaging the unit or your floor.
- We do not recommend the use of power drill/drivers for inserting screws, as this could damage the unit. Only use hand screwdrivers.
- Parts of the assembly will be easier with 2 people.
- Do not use this item if any components are missing or damaged.
- Dispose of all packaging carefully and responsibly.
- Assembly to be carried out by a competent adult only.

Assembly Tips

- Please read the instruction manual carefully to understand the matters needing attention in the process of installation and maintenance.
- Strictly follow the assembly instructions.
- Carefully check whether the parts in the box are intact.
- Assemble on the box so as not to damage the product and room floor.
- The use of mismatched parts may cause damage to the product. Please confirm the model of various parts before assembly.

PART LIST

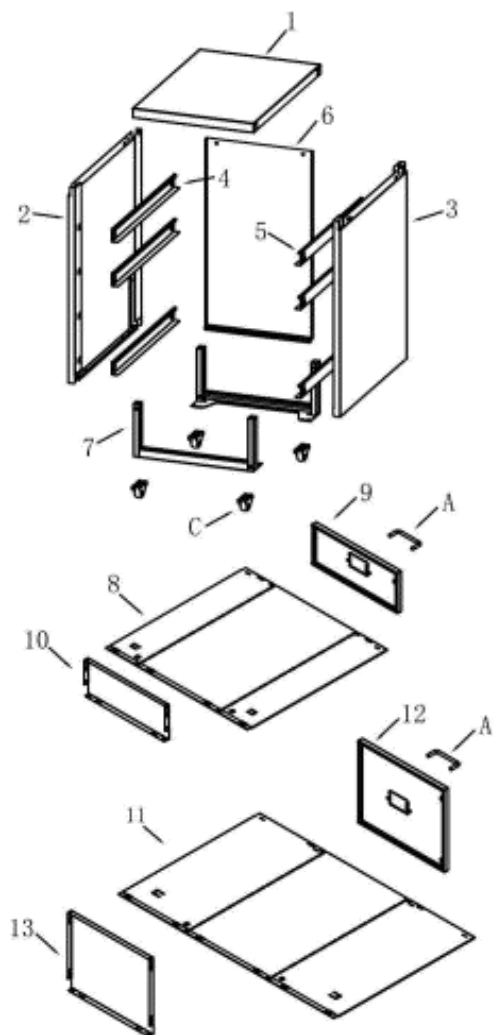

COMPONENTS



1: (x1)



2: (x1)



3: (x1)



4: (x4)



5: (x4)



6: (x1)



7: (x2)



8: (x2)



9: (x2)



10: (x2)

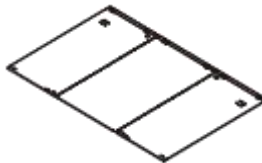

11: (x2)



12: (x2)



13: (x2)



A: (x4)



B: (x8)
M4 x 6



C: (x4)



D: (x12)



E: (x2)



F: (x4)

INSTALLATION

Step 1

Attach 4 to 2 as shown in the picture.

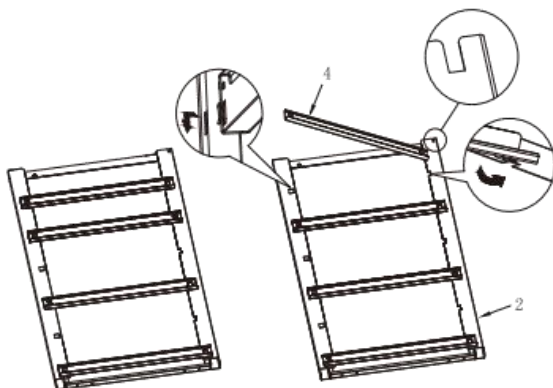

Step 2

Attach 5 to 3 as shown.

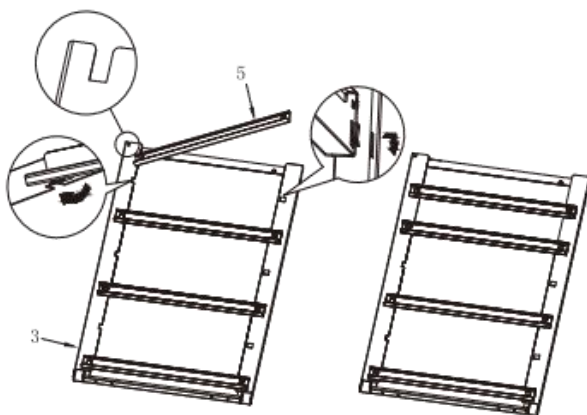

Step 3

Attach 7 to 3.

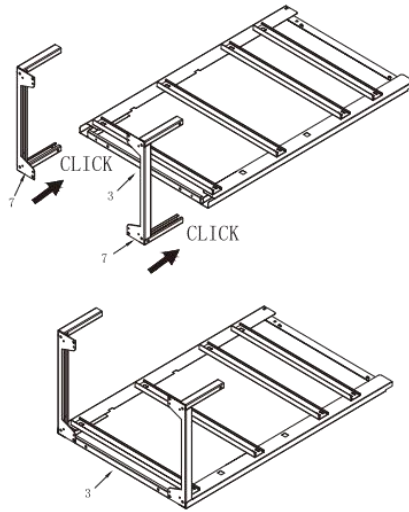

Step 4

Upright the assembled part of step 3. Then attach 2 and 6 to the assembled part of step 3 as shown.

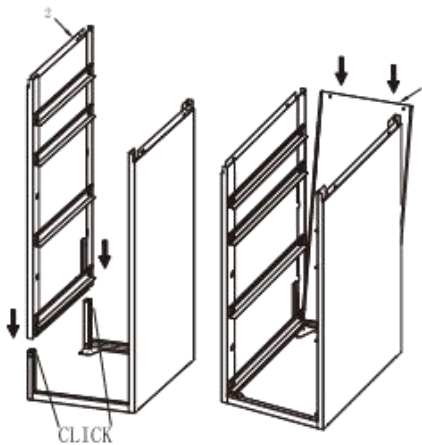

Step 5

Insert two E into the corresponding position as shown.

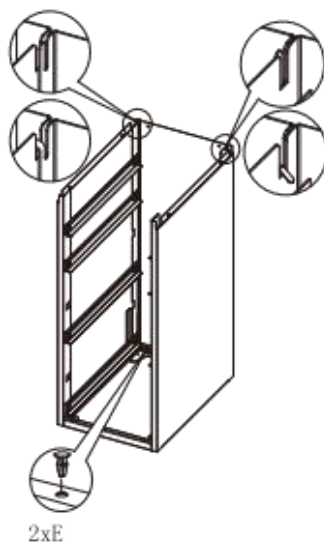

Step 6

Attach 1 to the top of the vertical file cabinet.

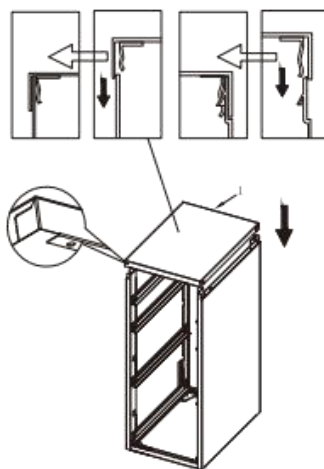

Step 7

Attach four C to the bottom of the cabinet with D.

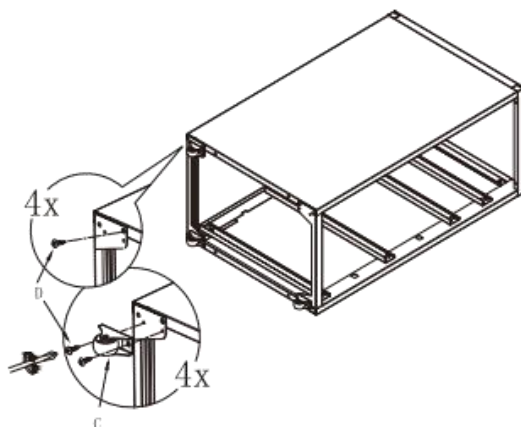

Step 8

Fold the two sides of the 8 as shown in the picture.

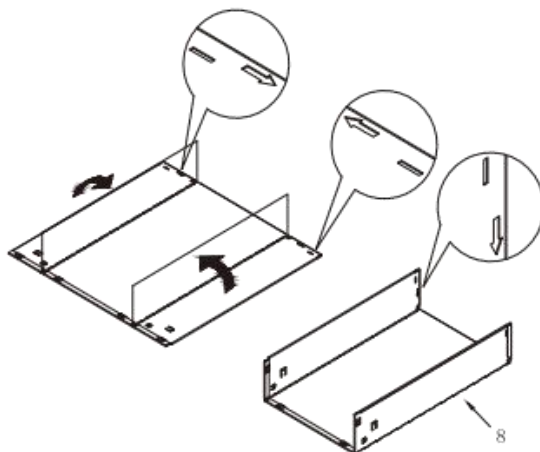

Step 9

Attach A to 9 with B.

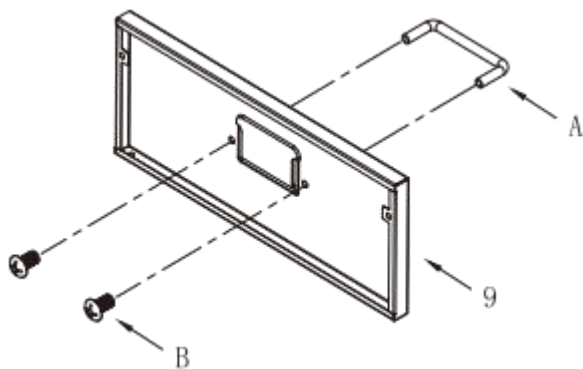

Step 10

Attach 9 to the assembled part of 8. Flex the corresponding position as shown.

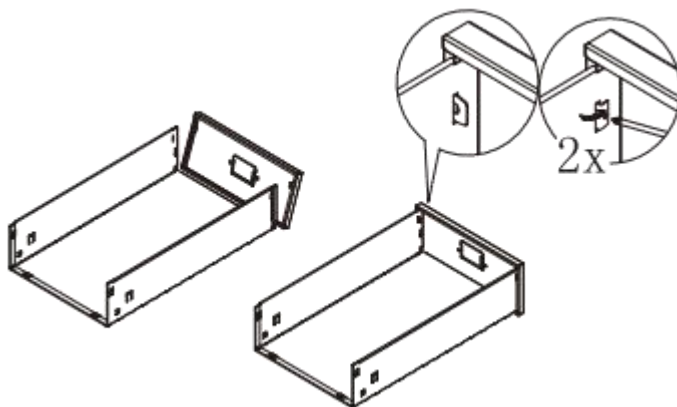

Step 11

Attach 10 to the assembled part of step 10 as shown.

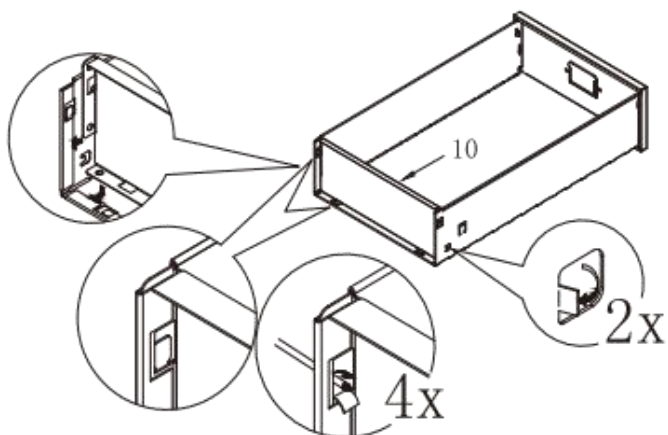

Step 12

Fold the two sides of the 11 as shown in the picture.

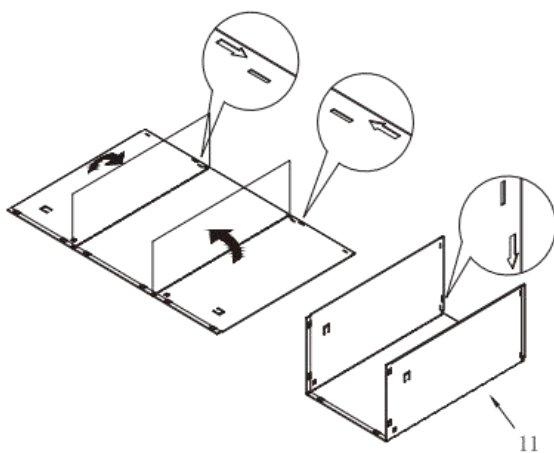

Step 13

Attach A to 12 with B.

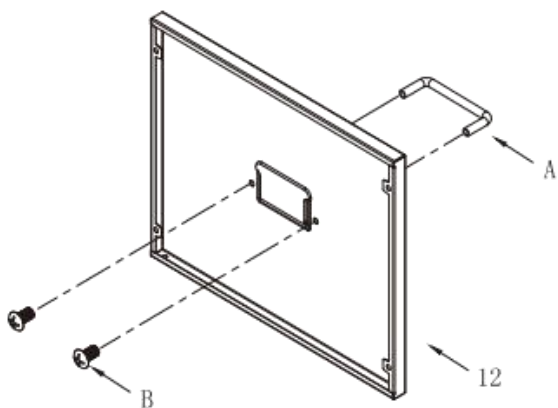

Step 14

Attach 12 to 11. Flex the corresponding position as shown.

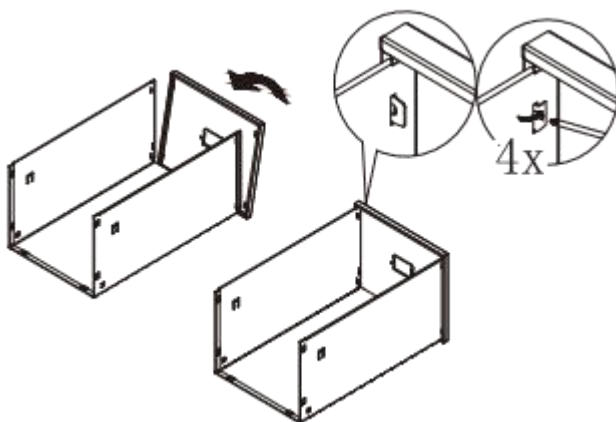

Step 15

Attach 13 to the assembled part of step 14.

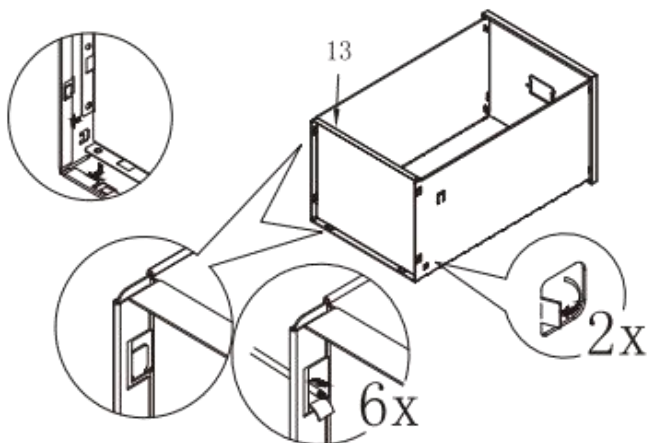

Step 16

Put the four drawers inside the cabinet frame and put the F in the corresponding position as shown.

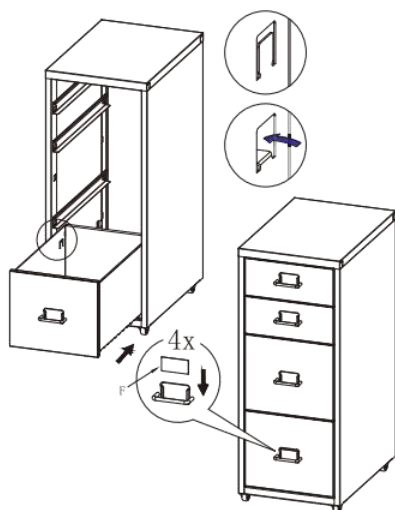

CLEANING & CARE

- Only clean using a damp cloth and mild detergent, do not use bleach or abrasive cleaners.
- Regularly check all fastenings to ensure that they properly tightened.
- This product should not be discarded with household waste. Take to your local authority waste disposal centre.

Living and Home

A Home is for Living in

For comfort and style update your living space.

Browse contemporary and classic designs and find the perfect home to your look and the perfect spot to lounge.

Put your feet up and sink into our stylish home decor.

We are mainly engaged in home, outdoor, home appliances, office, bathroom, provided high quality and affordable products for you. We value every one of our customers and our professional service team is always available to help you.

livingandhome.co.uk