



THERMOTEC INVERTER SWIMMING POOL HEAT PUMP

Installation & Instruction Manual
for Horizontal Models

9kw, 12kw, 17kw, 20kw, 24kw, 24kw 3-Phase (R32)



Table of contents

1. Preface	3
2. Specifications	
2.1 Performance Data	4
2.2 Dimensions	6
3. Installation and Connection	
3.1 Heat Pump Location	8
3.2 How Close to Your Pool?	8
3.3 Installation illustration	9
3.4 Installation of a check valve	9
3.5 Electrical Wiring	10
3.6 Initial Start-up of the Unit	10
3.7 Condensation	11
4. Operation and Use	
4.1 Display interface introduction	12
4.2 Button functions	13
4.3 Error codes	17
4.4 Error code list	18
5. Wiring diagrams	
5.1 Wire control interface diagram and definition	20
6. Maintenance and Inspection	24
7. Appendix	
7.1 Caution & Warning	25
7.2 Warranty	26
7.3 Explosive view of the unit	27

1. Preface

In order to provide our customers with quality, reliability and versatility, this product has been made to strict production standards. This manual includes all the necessary information about installation, debugging, discharging and maintenance. Please read this manual carefully before you open or maintain the unit. The manufacture of this product will not be held responsible if someone is injured or the unit is damaged, as a result of improper installation, debugging, or unnecessary maintenance. It is vital that the instructions within this manual are adhered to at all times. The unit must be installed by qualified personnel.

The unit can only be repaired by qualified personnel or an authorized dealer.

Maintenance and operation must be carried out according to the recommended time and frequency, as stated in this manual.

Use genuine standard spare parts only.

Failure to comply with these recommendations will invalidate the warranty.

Swimming Pool Heat Pump Unit heats the swimming pool water and keeps the temperature constant.

Our heat pump has following characteristics:

- **Durable**
The heat exchanger is made of PVC & Titanium tube which can withstand prolonged exposure to swimming pool water.
- **Installation flexibility**
The unit can be installed outdoors or indoors.
- **Quiet operation**
The unit comprises an efficient rotary/ scroll compressor and a low-noise fan motor, which guarantees its quiet operation.
- **Advanced controlling**
The unit includes micro-computer controlling, allowing all operation parameters to be set. Operation status can be displayed on the LCD wire controller. Remote controller can be chosen as future option.

2. Specifications

2.1 Performance data

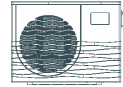

UNIT		Thermotec Inverter 9kw	Thermotec Inverter 12kw	Thermotec Inverter 17kw
Max Pool volume*	m ³	20 - 40	30 - 60	40 - 75
Advised Max Pool volume **	m ³	30	40	50
Operating air temperature	°C	-15 to 43		
Air 27°C / Water 26°C / Humidity 80%				
Heating Capacity	kW	2,15 - 9,0	2,85 - 12	3,77 - 17
	Btu	7310 - 30600	9690 - 40800	12818 - 57800
Consumed power	kW	0,16 - 1,60	0,21 - 2,12	0,3 - 3,02
COP		13,44 - 5,63	13,57 - 5,66	12,57 - 5,63
Air 15°C / Water 26°C / Humidity 70%				
Heating Capacity	kW	1,75 - 7,4	2,25 - 9,7	2,92 - 12,4
	Btu	5950 - 25160	7650 - 32980	9928 - 42160
Consumed power	kW	0,25 - 1,60	0,32 - 2,08	0,44 - 2,86
COP		7,0 - 4,63	7,03 - 4,66	6,64 - 4,34
Air 10°C / Water 26°C / Humidity 64%				
Heating Capacity	kW	1,42 - 6,1	1,88 - 8	2,5 - 10,7
	Btu	4828 - 20740	6329 - 27200	8500 - 36380
Consumed power	kW	0,25 - 1,5	0,33 - 1,95	0,45 - 2,64
COP		5,68 - 4,07	5,7 - 4,1	5,56 - 4,05
Power supply		230V~/ 50Hz		
Nominal Heating Capacity	kW	4,29	7,1	9,7
Nominal power input	kW	0,74	0,99	1,38
Max power input	kW	1,97	2,5	3,2
Nominal Running current	A	3,35	4,3	6
Current range	A	1,29 - 6,86	0,9 - 9,2	1,3 - 11,8
Max Current	A	9,9	12	12,8
Compressor quantity		1	1	1
Compressor type		Rotary	Rotary	Rotary
Refrigerant		R32		
Fan quantity		1	1	1
Fan power input	W	100	100	120
Fan rotary speed	RPM	500 - 700	500 - 650	600 - 700
Fan direction		Horizontal	Horizontal	Horizontal
Noise	dB(A)	40	42	44
Water connection	mm	50	50	50
Nominal water flow	m ³ /h	3,5	4,7	5,4
Water pressure drop (max)	kPa	4	4,5	5
Unit net dimensions (L*W*H)	mm	See the drawing of the units		
Unit shipping dimensions (L*W*H)	mm	See package label		
Net weight	kg	See nameplate		
Shipping weight	kg	See package label		

* Max pool volume for an entirely insulated pool, with cover, free from wind and exposed to the sun
 In case the pool volume is close to the maximum value, the inverter heat pump will nearly always run at full power

** Advised pool volume for efficient heating

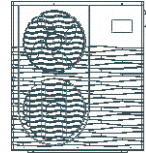
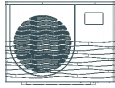

UNIT		Thermotec Inverter 20kw	Thermotec Inverter 24kw	Thermotec Inverter TRI 24kw
Max Pool volume*	m ³	50-95	65 - 120	65 - 120
Advised Pool volume **	m ³	65	75	75
Operating air temperature	°C	-15 to 43	-15 to 43	-15 to 43
Air 27°C / Water 26°C / Humidity 80%				
Heating Capacity	kW	4,6 - 19,5	5,7 - 24,2	5,7 - 24,2
	Btu	15640 - 66300	19380 - 82280	19380 - 82280
Consumed power	kW	0,37 - 3,94	0,46 - 4,8	0,46 - 4,8
COP		12,43 - 4,95	12,39 - 5,04	12,39 - 5,04
Air 15°C / Water 26°C / Humidity 70%				
Heating Capacity	kW	3,84 - 15,4	4,68 - 19,9	4,7 - 19,9
	Btu	13056 - 52360	15912 - 67660	15980 - 67660
Consumed power	kW	0,6 - 3,81	0,72 - 4,74	0,72 - 4,74
COP		6,4 - 4,04	6,5 - 4,2	6,53 - 4,2
Air 10°C / Water 26°C / Humidity 64%				
Heating Capacity	kW	3,38 - 14,4	4,2 - 17,8	4,2 - 17,8
	Btu	11492 - 48960	14280 - 60520	14280 - 60520
Consumed power	kW	0,62 - 3,62	0,75 - 4,4	0,75 - 4,4
COP		5,45 - 3,98	5,6 - 4,05	5,6 - 4,05
Power supply		230V~/ 50Hz	230V~/ 50Hz	380-415V/3N~/50Hz
Nominal Heating Capacity	kW	11,5	14,3	14,3
Nominal power input	kW	1,72	2,1	2,1
Max power input	kW	4,88	5,52	6,78
Nominal Running current	A	7,5	9,1	3,8
Current range	A	1,6 - 17,1	2 - 20,9	2,1-9,4
Max Current	A	17,3	23	10,61
Compressor quantity		1	1	1
Compressor type		Rotary	Rotary	Rotary
Refrigerant			R32	
Fan quantity		1	2	2
Fan power input	W	120	200	200
Fan rotary speed	RPM	500 - 750	400 - 600	400 - 800
Fan direction		Horizontal	Horizontal	Horizontal
Noise	dB(A)	45	46	46
Water connection	mm	50	50	50
Nominal water flow	m ³ /h	6,7	8,6	8,5
Water pressure drop (max)	kPa	6	11	11
Unit net dimensions (L*W*H)	mm	See the drawing of the units		
Unit shipping dimensions (L*W*H)	mm	See package label		
Net weight	kg	See nameplate		
Shipping weight	kg	See package label		

* Max pool volume for an entirely insulated pool, with cover, free from wind and exposed to the sun
 In case the pool volume is close to the maximum value, the inverter heat pump will nearly always run at full power

** Advised pool volume for efficient heating

2.2 Dimensions

Thermotec Inverter 9kw/12kw

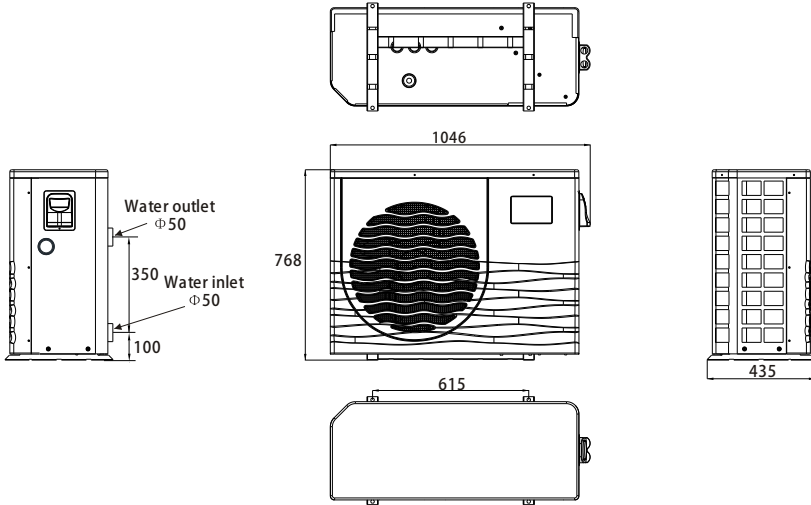

Thermotec Inverter 17kw/20kw

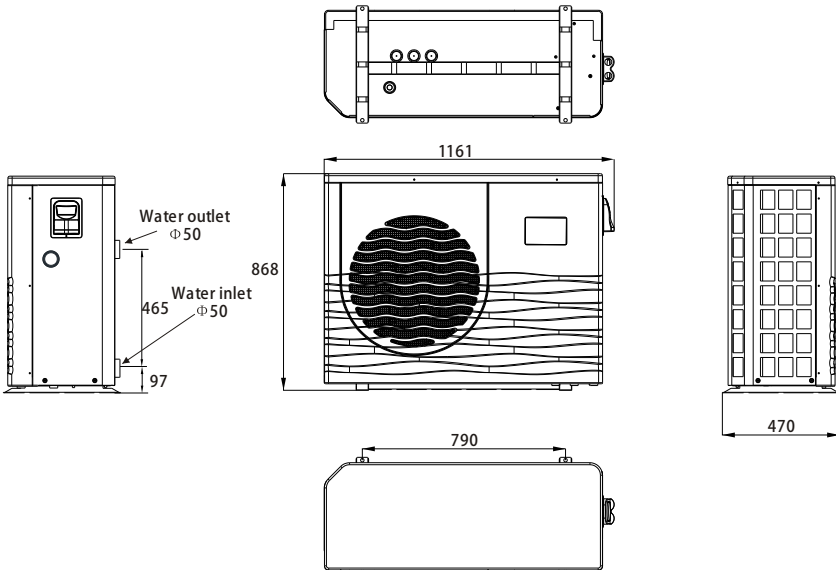

Thermotec Inverter 24kw/TRI 24kw

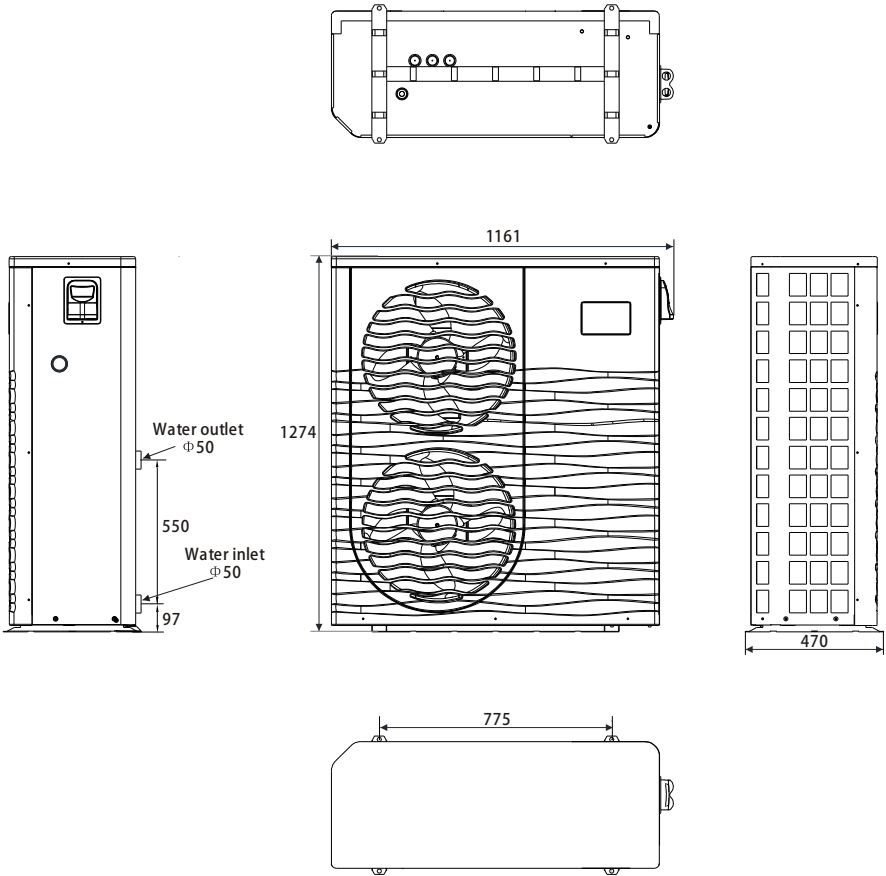

3. Installation and Connection

3.1 Heat Pump Location

The unit will perform well in any outdoor location provided that the following three factors are presented:

1. Fresh Air - 2. Electricity - 3. Pool filter piping

The unit may be installed virtually anywhere outdoors. For indoor pools please consult the supplier. Unlike a gas heater, it has no draft or pilot light problem in a windy area.

DO NOT place the unit in an enclosed area with a limited air volume, where the units discharge air will be re-circulated.

DO NOT place the unit to shrubs which can block air inlet. These locations deny the unit of a continuous source of fresh air which reduces its efficiency and may prevent adequate heat delivery.

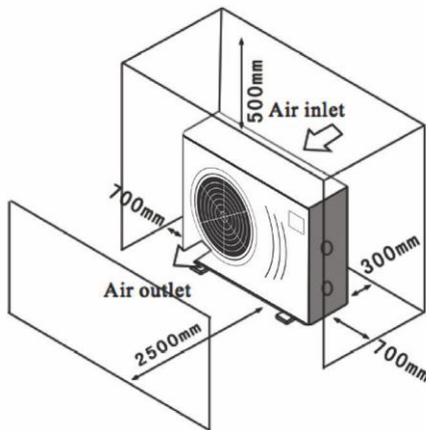

3.2 How Close To Your Pool?

Normally, the pool heat pump is installed within 7.5 meters of the pool. The longer the distance from the pool, the greater the heat loss from the piping. For the most part, the piping is buried. Therefore, the heat loss is minimal for runs of up to 15 meters (15 meters to and from the pump = 30 meters total), unless the ground is wet or the water table is high. A very rough estimate of heat loss per 30 meters is 0.6 kW-hour, (2000BTU) for every 5°C difference in temperature between the pool water and the ground surrounding the pipe, which translates to about 3% to 5% increase in run time.

3.3 Installation illustration

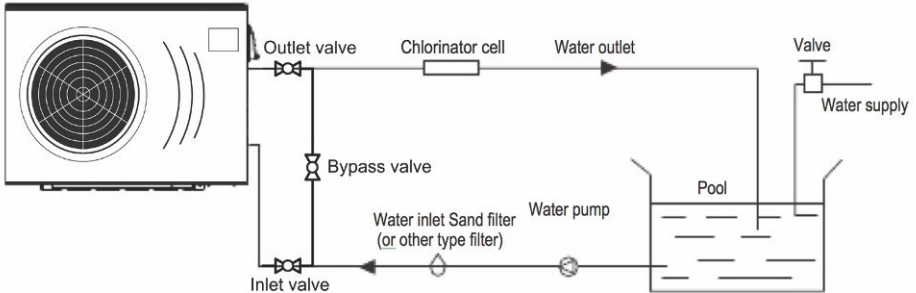

Remarks:

The factory only provides the heat pump. Other parts, including a contingent by-pass are to be provided by the user or installer.

Attention:

Please take the following steps when installing the heat pump:

1. Each addition of chemicals has to be performed through the conduits located AFTER the heat pump.
2. Install a by-pass for easy maintenance
3. Always place the heat pump on a solid base and use the supplied silent blocks in order to avoid vibrations and noise.
4. Always keep the heat pump in upright position. If the unit has been tilted, you should wait for at least 24 hours before turning it on.

3.4 Installation of a check valve

When using automatic chlorine and pH dosage systems, it is of uttermost importance to protect the heat pump from high concentrations of these chemicals that could corrode the heat exchanger. Therefore, such systems should add the chemicals in the conduits located DOWNSTREAM of the heat pump and it is recommended to install a check-valve in order to prevent backflow when there is no water circulation.

Damage to the heat pump caused by disregarding any of these recommendations will invalidate the warranty.

3.5 Electrical Wiring

Important - Although the heat pump is electrically isolated from the rest of the unit, this only prevents the passage of electricity to or from the pool water. Grounding the unit is still required to protect yourself from short circuits inside the unit. Make for adequate ground connection.

Check if the electrical mains voltage corresponds with the operating voltage of the heat pump prior to hooking up the unit.

It is recommended to use a separate fuse (C-curve) as well as adequate wiring (see table below). Connect the electrical wires with the terminal block labelled 'TO POWER SUPPLY'.

we do not recommend that you wire the pool circulation pump to the heat pump. Run separate power supplies to the heat pump and the pool circulation pump. This allows the pool circulation pump to be put on a time clock and operated for the required time to give adequate filtration for the pool and also the pool circulation pump can be manually operated when required to backwash the filter etc.

Model	Voltage (V)	Fuse (C-curve)	Max current (A)	Cable section*
Thermotec Inverter 9kw	220-240V	20	9,9	2,5 mm ²
Thermotec Inverter 12kw	220-240V	20	12	2,5 mm ²
Thermotec Inverter 17kw	220-240V	20	12,8	2,5 mm ²
Thermotec Inverter 20kw	220-240V	32	17,3	4 mm ²
Thermotec Inverter 24kw	220-240V	32	23	4 mm ²
Thermotec Inverter TRI 24kw	380-415V	20	10.61	4 mm ²

* For a maximum cable length of 50m

3.6 Initial startup of the Unit

NOTE- In order for the unit to heat the pool or spa, the filter pump must be running to circulate water through the heat exchanger.

Start up Procedure - After installation is completed, you should follow these steps:

1. Turn on your filter pump. Check for water leaks and verify flow to and from the pool.
2. Turn on the electrical power supply to the heat pump, then press the key ON/OFF of wire controller, It should start in several seconds.
3. After running a few minutes make sure the air leaving the fan opening of the unit is cooler (between 5-10°C)
4. With the unit operating turn the filter pump off. The unit should also turn off automatically,
5. Allow the unit and pool pump to run 24 hours per day until desired pool water temperature is reached. When the desired pool water temperature reaches the setting, the unit just shuts off. The unit will now automatically restart (as long as your filter pump is running) when the pool temperature drops more than 2°C below set temperature.

Time Delay- The unit is equipped with a 3 minute built-in solid state restart delay included to protect control circuit components and to eliminate restart cycling and contactor chatter. This time delay will automatically restart the unit approximately 3 minutes after each control circuit interruption. Even a brief power interruption will activate the solid state 3 minute restart delay and prevent the unit from starting until the 5 minute countdown is completed. Power interruptions during the delay period will have no effect on the 3 minute countdown.

3.7 Condensation

Since the Heat pump cools down the air about 5°C, water may condense on the fins of the evaporator. If the relative humidity is very high, this could be as much as several litres an hour. The water will run down the fins into the base pan and drain out through the barbed plastic condensation drain fitting on the side of the base pan.

This fitting is designed to accept 20mm clear vinyl tubing which can be pushed on by hand and run to a suitable drain. It is easy to mistake the condensation for a water leak inside the unit.

TIP:

A quick way to verify that the water is condensation is to shut off the unit and keep the pool pump running. If the water stops running out of the base pan, it is condensation. AN EVEN QUICKER WAY IS TO TEST THE DRAIN WATER FOR CHLORINE - if there is no chlorine present, then it's condensation.



Do not use means to accelerate the defrosting process or to clean, Other than those recommended by the manufacturer.

The appliance shall be stored in a room without continuously operating ignition sources (for example: open flames, an operating gas appliance or an operating electric heater.)

Do not pierce or burn.

Be aware that refrigerants may not contain an odour,

Appliance shall be installed, operated and stored in a room with a floor area larger than X m².

NOTE The manufacturer may provide other suitable examples or may provide additional information about the refrigerant odour.

4. Operation and Use

4.1 Display interface introduction

1. Main interface



2. Button description

NO.	Name	button function
1	ON/OFF	Start/Stop the unit
2	Lock screen	Locks the screen
3	Parameters	Access to parameters
4	Clock settings	- Set the date & time - Activate timers
5	Error codes	View error code history
6	Silent settings	- Press to activate silent function - Set timing Low speed function
7	Mode	Mode switch interface
8	Statistics	View temperature and power curve
9	Water temperature	Mode settings and target temp setting interface

4.2 Button functions

1. ON/OFF

With the ON/OFF button, the heat pump is turned ON or OFF (stand-by status)

2. LOCK SCREEN

Press this button to lock the screen

To unlock: press the lock button and enter the code "22"

3. PARAMETERS

N/A

4. CLOCK SETTINGS

In the main interface, tap on the clock Settings button 3, interface displays as follows:

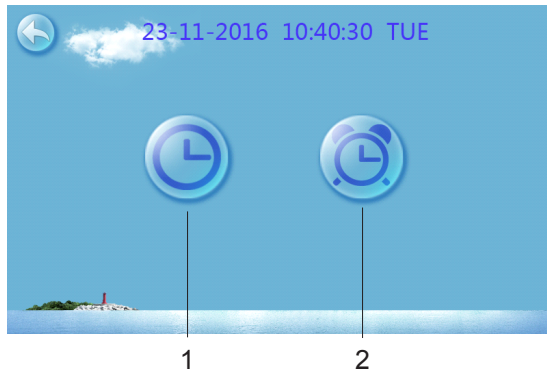

Setting the time

tap on the Time Settings button (1), then the following menu pops up:

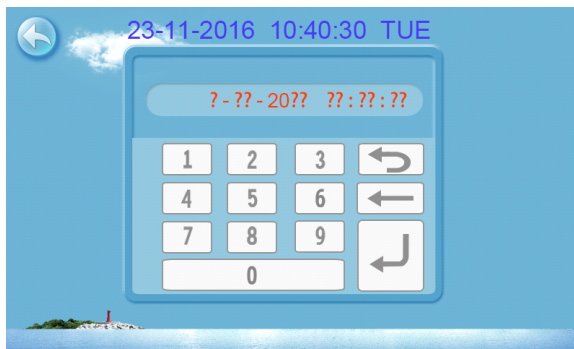

Tap the value to set time directly, the tap the Enter button to save the Settings.
For example: setup time: the 02-25-2016 15:00:00, input 15 00 00 02 25 16

Note:

if the input format is not correct, the setting can not be saved by tapping Enter.

Setting/activating the Timers

Tap the TIMER set button (2), to enter the timer menu

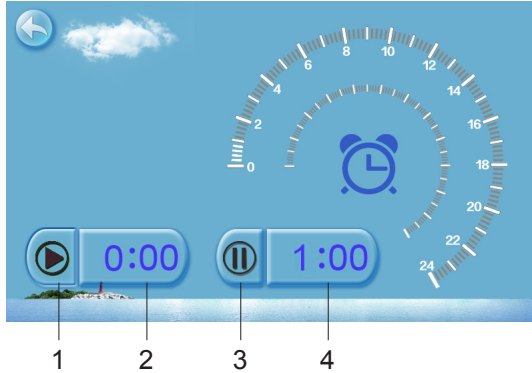

NO	Name	Button color	Button function
1	TIMER START	Activated: Green Not activated: Grey	Tap this button to activate/deactivate the START timer
2	Start time		Set Start time
3	TIMER END	Activated: Red Not activated: Grey	Tap this button to activate/deactivate the END timer
4	End time		Set End time

For example above: without action, 00:00 o'clock and 01:00 o'clock will be the on and off time of timing settings.

5. ERROR CODES

See section 4.3

6. SILENT SETTINGS

In the main screen, tap the silent settings button

A pop-up appears with 2 icons:

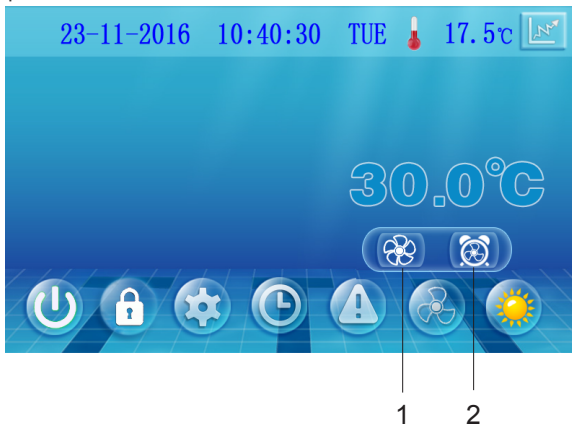

Direct silent mode

Tap the Direct silent button (1), the unit will enter silent mode directly.

The displays shows a fan icon with 3 blades to indicate that the silent mode is active

Tap the silent button again, to exit the silent mode.



Timed silent mode

Tap the Timed silent button (2)

The displays shows a menu with timer settings to activate/deactivate the silent mode

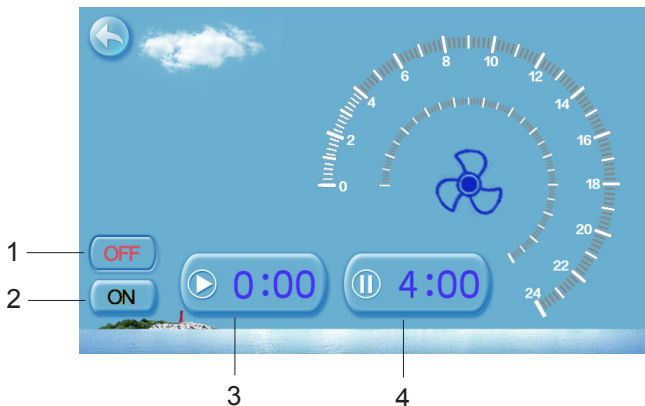

NO	Name	Button colour	Button function
1	Timer SILENT OFF	Activated: Red Not activated: Grey	Tap to activate/deactivate the END timer
2	Timer SILENT ON	Activated: Green Not activated: Grey	Tap to activate/deactivate the START timer
3	Start time		Set start time
4	End time		Set end time

For example above, Tap "ON" to use the Timed silent mode the unit will start the silent mode at 23:00h and end at 08:00h

Note: If the unit is running in silent mode, and the OFF button (1) is tapped, then the unit will exit silent mode immediately

7. MODE

In the main screen, tap the Mode button.
A new menu will pop up:

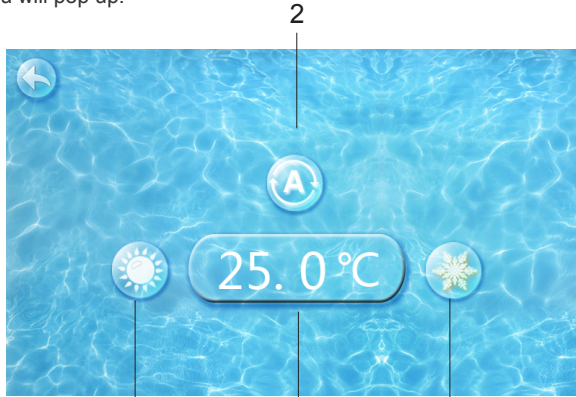

- 1) Cooling mode
- 2) Automatic heating/cooling mode
- 3) Heating mode
- 4) Set desired swimming pool temperature

8. STATISTICS

In the main screen, tap the Statistics button.
A new menu will pop up.

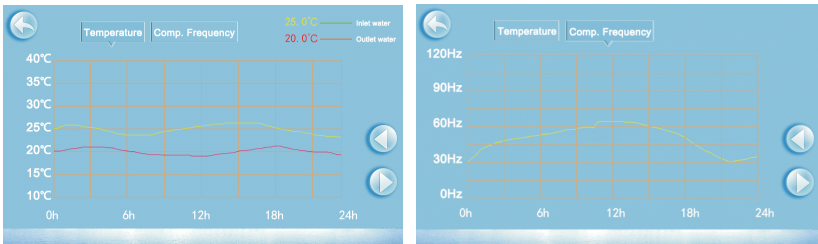

The temperature curve automatically updates every hour, and the curve record can be stored for 60 days
stored for 60 days

9. WATER TEMPERATURE

Set the desired swimming pool water temperature



4.3 Error codes

In the main screen, tap the Error codes button.

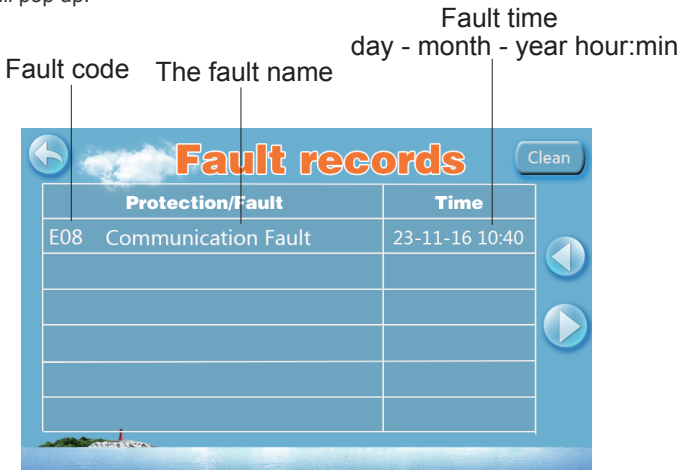
A new menu will pop up:



If there are no error codes present, the main display will show a grey triangle logo: 

When an error occurs, the error icon will flash orange/grey:  
the system will record the time, code and name of the error.

When an error occurs, and you don't check the Error code history menu, the main interface will display a static "" icon after a while.

If you do check Error code history menu, the main interface will display a static "" icon.

The Error code history menu shows all the error codes in reverse order, with the most recent code on top. If you tap the "Clean" key, you can erase all the codes.

Wi-Fi Module

4.4 Error code list

Protect/fault	Fault display	Reason	Elimination methods
Standby	non		
Normal boot	non		
Inlet temp. Sensor failure	P01	The temp. Sensor is broken or short circuit	Check or change the temp. Sensor
Outlet temp. Sensor failure	P02	The temp. Sensor is broken or short circuit	Check or change the temp. Sensor
Coil temp. Sensor failure	P04	The temp. Sensor is broken or short circuit	Check or change the temp. Sensor
Ambient temp. sensor failure	P05	The temp. Sensor is broken or short circuit	Check or change the temp. Sensor
Suction temp. sensor failure	P07	The temp. Sensor is broken or short circuit	Check or change the temp. Sensor
Exhaust temp. sensor failure	P081	The temp. Sensor is broken or short circuit	Check or change the temp. Sensor
High pressure protection	E01	The high-pressure switch is broken	Check the pressure switch and cold circuit
Low pressure protection	E02	Low pressure1 protection	Check the pressure switch and cold circuit
Flow failures	E03	No water/little water in water system	Check the pipe water flow and water pump
System anti freezing protection	E07	Water flow is not enough	Check the pipe water flow and whether the water system is jammed or not
The primary anti-freezing protection	E19	The ambient temp. Is low	
The secondary anti-freezing Protection	E29	The ambient temp. Is low	
Water-inlet and outlet temp	E06	Water flow is not enough and low differential pressure	Check the pipe water flow and whether the water system is jammed or not
Low temperature protection	non	The environment temp. is low	
Compressor too much electricity protection	E051	The compressor is overload	Check whether the system of the compressor is running normally
Exhaust Temp. Of system is too high	P082	The compressor is overload	Check whether the system of the compressor is running normally
Communication failure	E08	Communication failure between wire controller and main board	Check the wire connection between remote wire controller and main board
Antifreeze Temp. Sensor Fault	P09	antifreeze temp sensor is broken or short circuited	check and replace this temp sensor
EC fan feedback Fault	F051	There is something wrong with fan motor and fan motor stops	Check whether fan motor is broken or locked or not
Pressure sensor Fault	PP	The pressure Sensor is broken	Check or change the pressure Sensor or pressure

Protection/fault	Fault display	Reason	Elimination methods
MOP drive alarm	F01	MOP drive alarm	Recovery after the 150s
Frequency conversion board offline	F02	Frequency conversion board and main board communication failure	Check the communication connection
IPM modular protection	F03	IPM modular protection	Recovery after the 150s
Compressor start-up failure	F04	Lack of phase, step or drive hardware damage	Check the measuring voltage check frequency conversion board hardware
Dc fan fault	F05	Motor current feedback open circuit or short circuit	Check whether current return wires connected motor,
IPM Input current is large protection	F06	IPM Input current is large	Check and adjust the current measurement
Dc voltage is large	F07	DC bus voltage>Dc bus over-voltage protection value	Check the input voltage measurement
Dc voltage is not enough	F08	DC bus voltage<Dc bus over-voltage protection value	Check the input voltage measurement
Input voltage is not enough	F09	The input voltage is low, causing the input current is high	Check the input voltage measurement
Input voltage is large	F10	The input voltage is too high, more than outage protection current RMS	Check the input voltage measurement
Voltage sampling fault	F11	The input voltage sampling fault	Check and adjust the current measurement
DSP and PFC connect fault	F12	DSP and PFC connect fault	Check the communication connection
DSO and SPPB connect fault	F13	DSO and SPPB connect fault	Check the communication connection
DSP and MCU connect fault	F14	DSP and MCU connect fault	Check the communication connection
IPM overheating protection	F15	The IPM module is overheat	Check and adjust the current measurement
Weak magnetic field protection	F16	Compressor magnetic force is not enough	
The input voltage lost phase	F17	The input voltage lost phase	Check and measure the voltage adjustment
IPM sampling electricity	F18	IPM sampling electricity is fault	Check and adjust the current measurement
Radiator temperature sensor fault	F19	Sensor is short circuit or open circuit	Inspect and replace the sensor
Transducer overheating protection	F20	The transducer is overheat	Check and adjust the current measurement
Transducer overheating alarm	F22	Transducer temperature is too high	Check and adjust the current measurement
Compressor electricity large protection	F23	Compressor electricity is large	The compressor over-current protection
Input current too large alarm	F24	Input current is too large	Check and adjust the current measurement
EEPROM error alarm	F25	MCU error	Check whether the chip is damaged Replace the chip

5. Wiring diagrams

5.1 Wire control interface diagram and definition

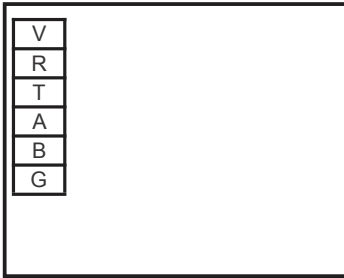

Terminal	Function
V	12V power +
R	Not used
T	Not used
A	485A
B	485B
G	GND (power -)

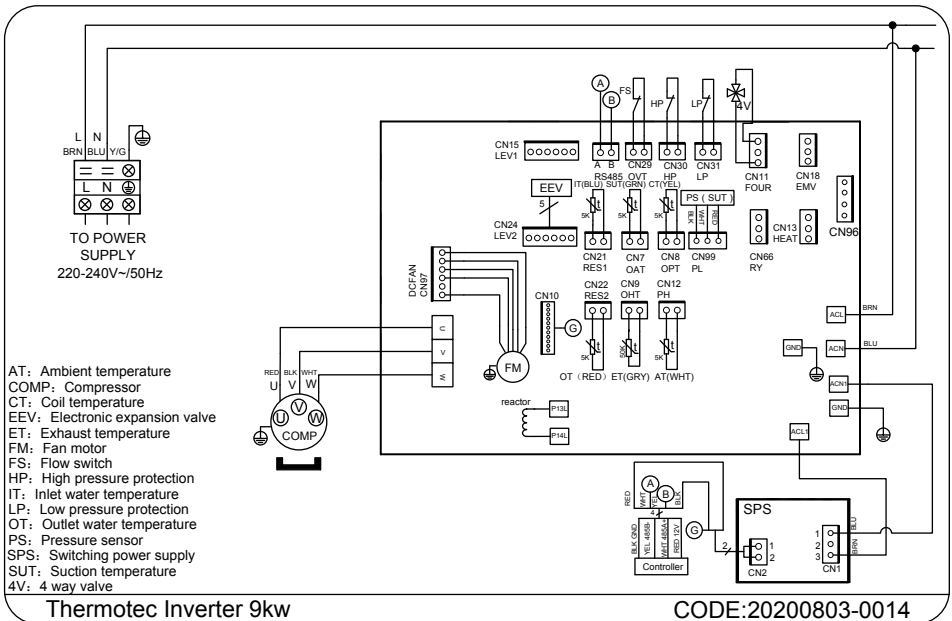

Thermotec Inverter 9kw

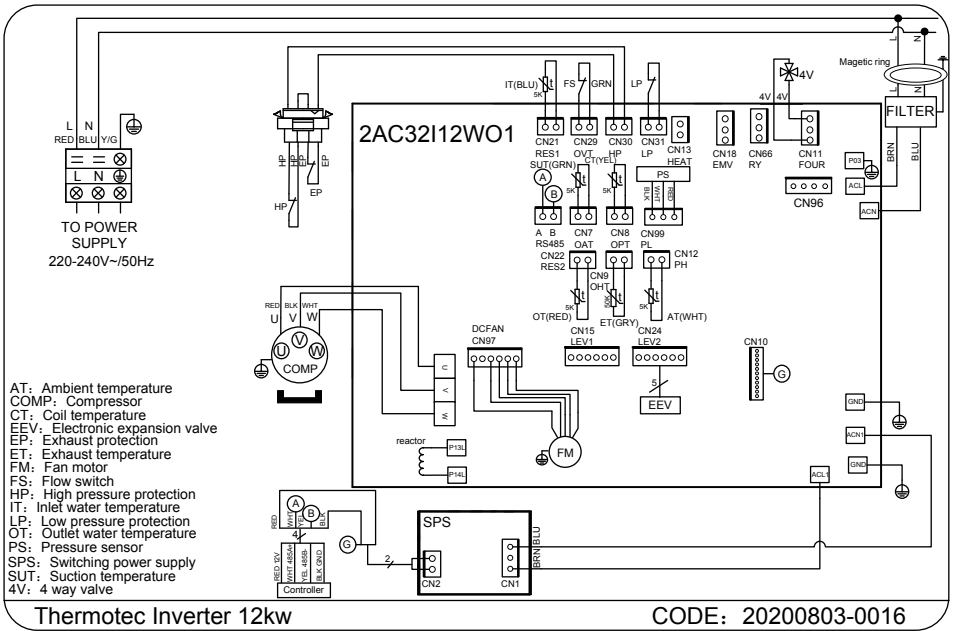

Thermotec Inverter 12kw

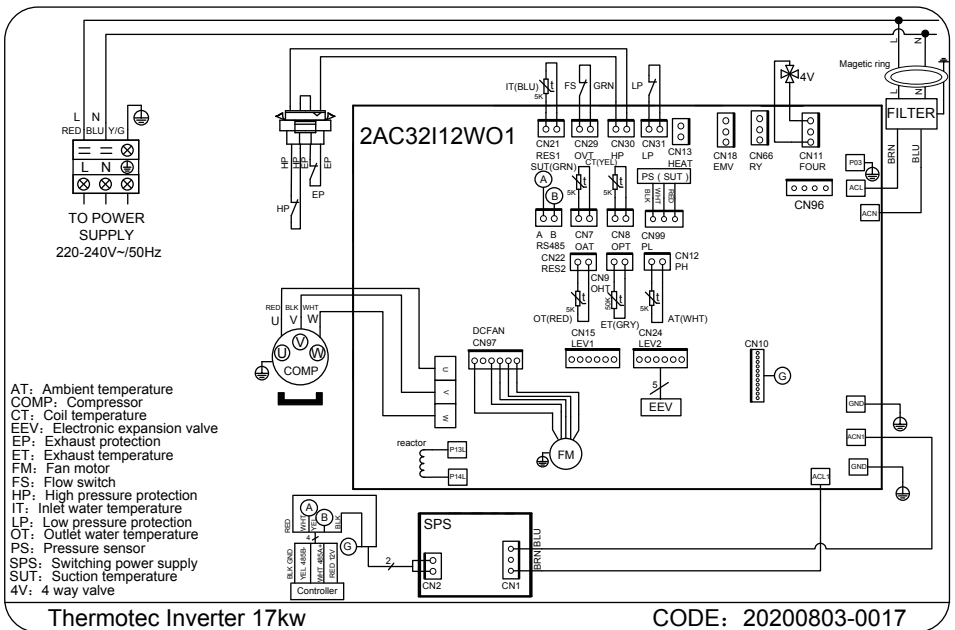

Thermotec Inverter 17kw

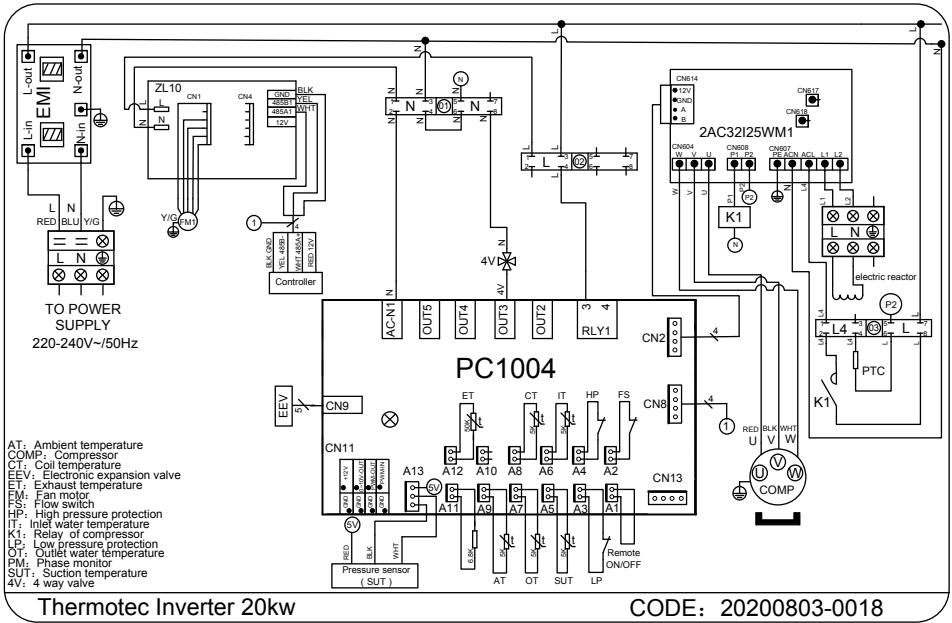

Thermotec Inverter 20kw

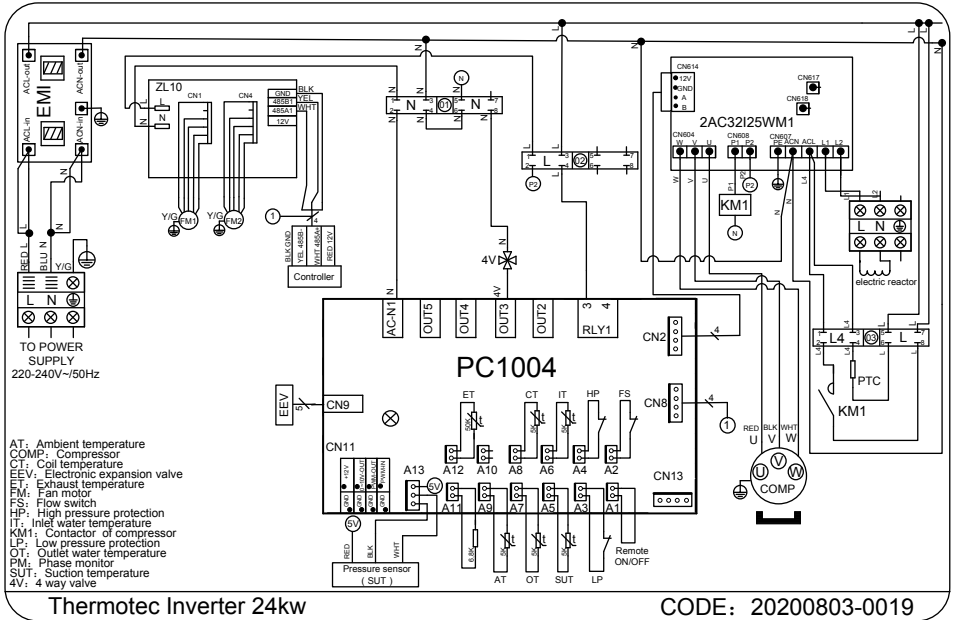

Thermotec Inverter 24kw

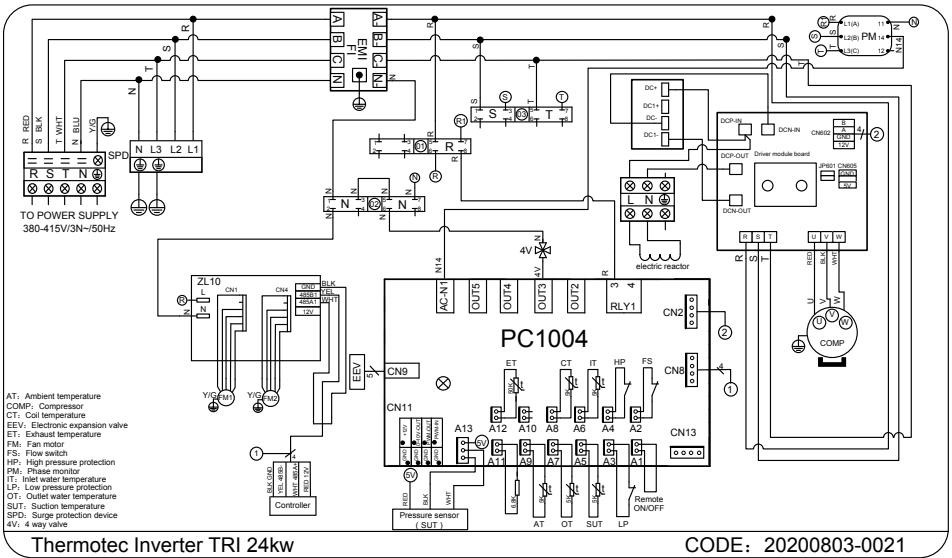

Thermotec Inverter TRI 24kw

6. Maintenance and Inspection

- Check the water inlet and drainage often. The water and air inflow into the system should be sufficient so that its performance and reliability does not get compromised. You should clean the pool filter regularly to avoid damage to the unit caused by clogging of the filter.
- The area around the unit should be spacious and well ventilated. Clean the sides of the heat pump regularly to maintain good heat exchange and to save energy.
- Check if all processes in the unit are operational and pay special attention to the operation pressure of the refrigerant system.
- Check the power supply and cable connections regularly. Should the unit begin to function abnormally or should you notice a smell from an electrical component, arrange for timely repair or replacement.
- Winterizing : make sure to drain all the water from the heat pump and other systems in order to prevent frost damage. Damage caused by freezing is not covered by the warranty.
- You should also purge the water if the unit will not work for an extended period of time. You should check all parts of the unit thoroughly and completely fill the system with water before turning it on again afterwards.

7. Appendix

7.1 Caution & Warning

1. The unit can only be repaired by qualified installer centre personnel or an authorised dealer.
2. This appliance is not intended for use by persons (including children) with reduced physical sensory or mental capabilities, or lack of experience and knowledge, unless they have been given supervision or instruction concerning use of the appliance by a person responsible for their safety. (for Europe market)
Children should be supervised to ensure that they do not play with the appliance.
3. Please make sure that the unit and power connection have good earthing, otherwise may cause electrical shock.
4. If the supply cord is damaged, it must be replaced by the manufacturer or our service agent or similarly qualified person in order to avoid a hazard.
5. Directive 2002/96/EC (WEEE):
The symbol depicting a crossed-out waste bin that is underneath the appliance indicates that this product, at the end of its useful life, must be handled separately from domestic waste, must be taken to a recycling centre for electric and electronic devices or handed back to the dealer when purchasing an equivalent appliance.
6. Directive 2002/95/EC (RoHs): This product is compliant with directive 2002/95/EC (RoHs) concerning restrictions for the use of harmful substances in electric and electronic devices.
7. The unit CANNOT be installed near the flammable gas. Once there is any leakage of the gas, fire can be occur.
8. Make sure that there is a circuit breaker for the unit, lack of a circuit breaker can lead to electrical shock or fire.
9. The heat pump is equipped with an over-load protection system. It does not allow for the unit to start for at least 3 minutes from a previous stoppage.
10. Installation must be performed in accordance with the NEC/CEC by authorized person only. (for North America market)
11. USE SUPPLY WIRES SUITABLE FOR 75°C .
12. Caution: Single wall heat exchanger, not suitable for potable water connection.

7.2 Warranty

EXTENDED WARRANTY

Thank you for purchasing our heat pump.

We warrant all parts to be free from manufacturing defects in materials and workmanship for a period of THREE years from the date of retail purchase.

LIMITED WARRANTY

This warranty is limited to the first retail purchaser, is not transferable, and does not apply to products that have been moved from their original installation sites. The liability of the Manufacturer shall not exceed the repair or replacement of defective parts and does not include any costs for labour to remove and reinstall the defective part, transportation to or from the factory, and any other materials required to make the repair. This warranty does not cover failures or malfunctions resulting from the following:

1. Failure to properly install, operate or maintain the product in accordance with our published "Installation & Instruction Manual" provided with the product.
2. The workmanship of any installer of the product.
3. Not maintaining a proper chemical balance in your pool [pH level between 7,0 and 7,8. Total Alkalinity (TA) between 80 to 150 ppm. Free Chlorine between 0,5 – 1,2mg/l. Total Dissolved Solids (TDS) less than 1200 ppm. Salt maximum 8g/l]
4. Abuse, alteration, accident, fire, flood, lightning, rodents, insects, negligence or acts of Gods.
5. Scaling, freezing or other conditions causing inadequate water circulation.
6. Operating the product at water flow rates outside the published minimum and maximum specifications.
7. Use of non-factory authorized parts or accessories in conjunction with the product.
8. Chemical contamination of combustion air or improper use of sanitizing chemicals, such as introducing sanitizing chemicals upstream of the heater and cleaner hose or through the skimmer.
9. Overheating, incorrect wire runs, improper electrical supply, collateral damage caused by failure of O-rings, DE grids or cartridge elements, or damage caused by running the pump with insufficient quantities of water.

LIMITATION OF LIABILITY

This is the only warranty given by Manufacturer. No one is authorized to make any other warranties on our behalf.

THIS WARRANTY IS IN LIEU OF ALL OTHER WARRANTIES, EXPRESSED OR IMPLIED, INCLUDING BUT NOT LIMITED TO ANY IMPLIED WARRANTY OF FITNESS FOR A PARTICULAR PURPOSE AND MERCHANTABILITY. WE EXPRESSLY DISCLAIM AND EXCLUDE ANY LIABILITY FOR CONSEQUENTIAL, INCIDENTAL, INDIRECT OR PUNITIVE DAMAGES FOR BREACH OF ANY EXPRESSED OR IMPLIED WARRANTY.

This warranty gives you specific legal rights, which may vary, by country.

WARRANTY CLAIMS

For prompt warranty consideration, contact your dealer and provide the following information: proof of purchase, model number, serial number and date of installation. The installer will contact the factory for instructions regarding the claim and to determine the location of the nearest service centre.

All returned parts must have a Return Material Authorization number to be evaluated under the terms of this warranty.

7.3 Explosive view of the unit

Model and code:(Thermotec Inverter 9kw)

1 Complete machine structure explosion diagram

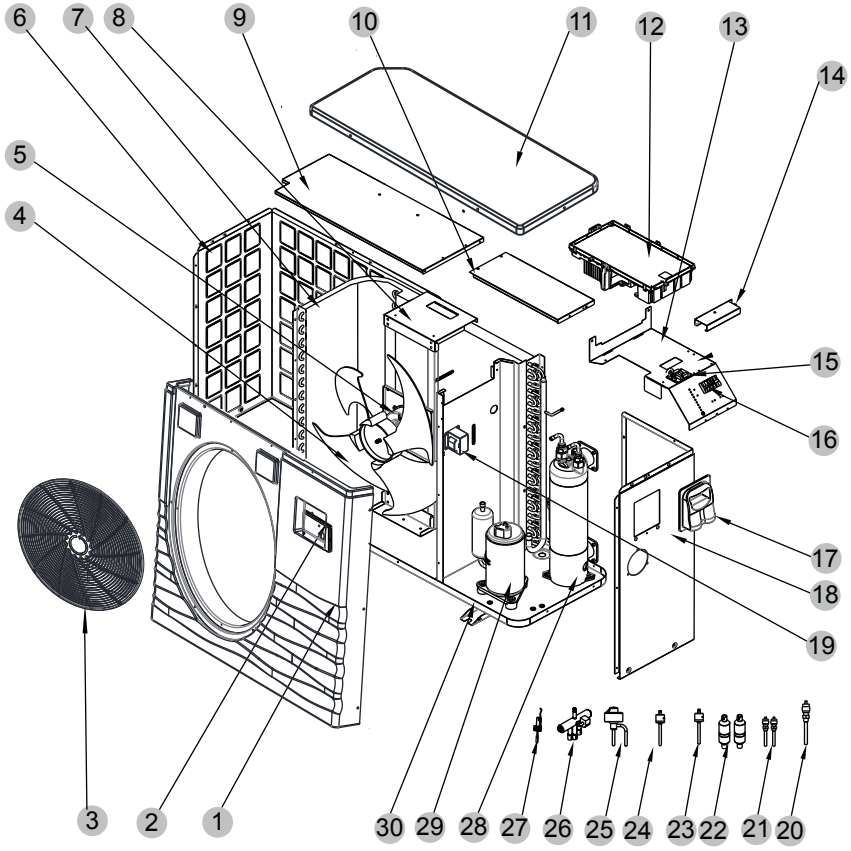

No.	Code	Name	Specifications	Qty
1	80900248	Front panel	ABS	1
2	95005-310500	CP302	20000-430176+35005-310500	1
3	80900080	Fan protection net	ABS	1
4	20000-270004	Axial Flow Fan Blade	Z500-145	1
5	20000-330132	DC Motor	ZWS75-A	1
6	80700244	Back Net	Gray 7004	1
7	80600044	Finned Tube Heat Exchanger	680×290×700×Φ7×1.5	1
8	80700248	Motor Bracket	Galvanized sheet	1
9	80700246	Top Support Plate	Galvanized sheet	1
10	80700700	Top Support Plate 2	Galvanized sheet	1
11	301090-20080006	Top Cover	ABS	1
12	72200094	Inverter drive module	82300008+82400021	1
13	80701504	Electrical Support Plate	Galvanized sheet	1
14	80701505	Electrical Support Frame	Galvanized sheet	1
15	82600008	Switching power supply	EPS-15-12	1
16	2000-3928	3-Position Wire Holder	RS9101(450V~ 4mm2)(L、N、PE)	1
17	32009-220029	Wiring Box	ABS	1
18	80700243	Right Panel	Galvanized sheet	1
19	82500006	Reactance	R1650FNKZ 16A 50Hz 5mH	1
20	20000-140512	Needle Valve	95mm 7/16"	1
21	20000-140150	Needle Valve	40mm 1/2"	1
22	2004-1444	Filter	Φ9.7-Φ9.7 (Φ28) T2Y2	2
23	2001-3605	Pressure Switch	3.2MPa/4.4MPa ±0.15	1
24	20000-360157	Pressure Switch	0.30MPa/0.15MPa ±0.05	2
25	81000015	Electronic Expansion Valve	DPF(TS1)1.65C-07	1
26	2004-1437	Four-way Valve	SHF-9H-35U-P	1
27	83000068	Water Switch (Mould Opening)	PSL-1 3/4	1
28	80600074	Titanium Heat Exchanger	Φ9.52×9m Φ110	1
29	20000-110448	Compressor	SVB140FCAMC	1
30	80700242	Chassis	Galvanized sheet	1

7.3 Explosive view of the unit

Model and code:(Thermotec Inverter 12kw)

1 Complete machine structure explosion diagram

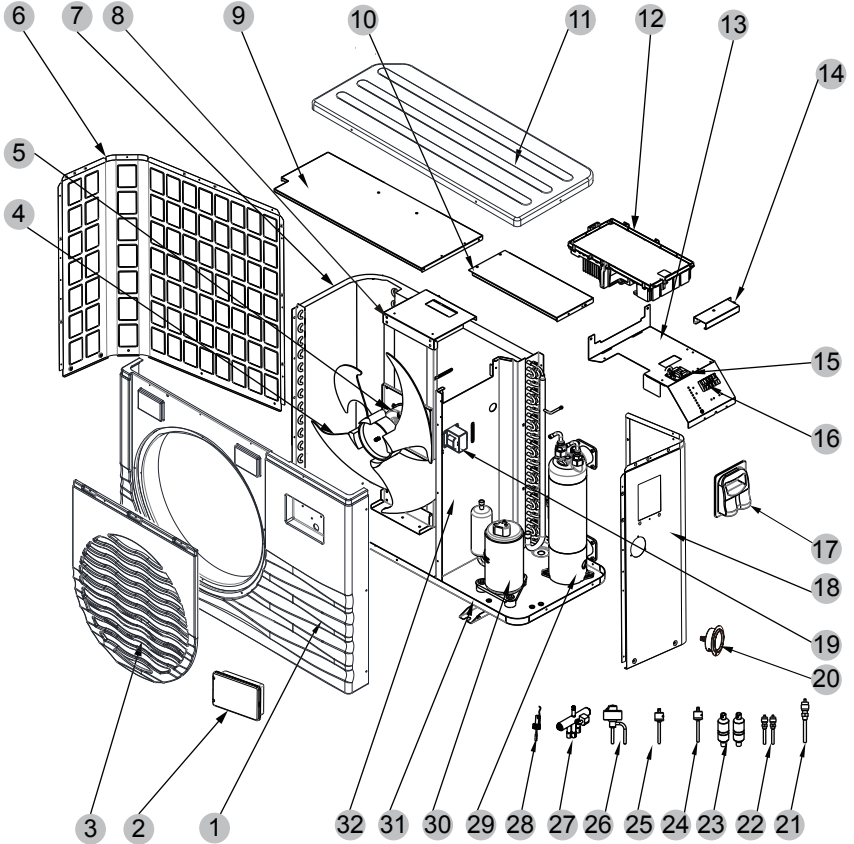

No.	Code	Name	Specifications	Qty
1	80900248	Front panel	ABS	1
2	95005-310500	CP302	20000-430176+35005-310500	1
3	80900080	Fan protection net	ABS	1
4	20000-270004	Axial Flow Fan Blade	Z500-145	1
5	20000-330132	DC Moto	ZWS75-A	1
6	80700244	Back Net	Galvanized plate	1
7	80600100	Finned Tube Heat Exchanger	680×290×700×Φ7×2 2.0	1
8	80700248	Motor Bracket	Galvanized plate	1
9	80700246	Top Support Plate	Galvanized plate	1
10	80700700	Top Support Plate 2	Galvanized plate	1
11	80900625	Top Cover	ABS	1
12	72200015	Controller	82300007+82400021	1
13	80701504	Electrical Support Plate	Galvanized plate	1
14	80701505	Electrical Support Frame	Galvanized plate	1
15	82600008	Switching power supply	EPS-15-12	1
16	2000-3928	3-position wiring base	RS9101(450V~ 4mm2)(L、N、PE)	1
17	32009-220029	Wiring Box	ABS	1
18	80700243	Right Panel	Galvanized plate	1
19	82500005	reactor	R2050FNKZ 20A 50Hz 5.2mH	1
20	81900044	Pressure gauge	0-55Kg/cm2	1
21	20000-140512	Needle Valve	95mm 7/16"	1
22	20000-140150	Needle Valve	40mm 1/2"	2
23	2004-1444	Filter(R410A)	Φ9.7-Φ9.7 (Φ28) T2Y2	2
24	2001-3605	Pressure Switch	3.2MPa/4.4MPa ±0.15	1
25	20000-360157	Low pressure switch	0.30MPa/0.15MPa ±0.05	1
26	81000016	Electronic expansion valve	DPF(TS1)1.8C-03	1
27	2004-1437	Four-way Valve	SHF-9H-35U-P	1
28	83000068	Water Switch (Mould Opening)	PSL-1 3/4	1
29	80600096	Titanium Heat Exchanger	Φ9.52×10m Φ110	1
30	80100046	Compressor	SVB220FLGMC-L	1
31	80700242	Chassis	Galvanized plate	1
32	80700245	Middle Plate	Galvanized plate	1

7.3 Explosive view of the unit

Model and code:(Thermotec Inverter 17kw)

1 Complete machine structure explosion diagram

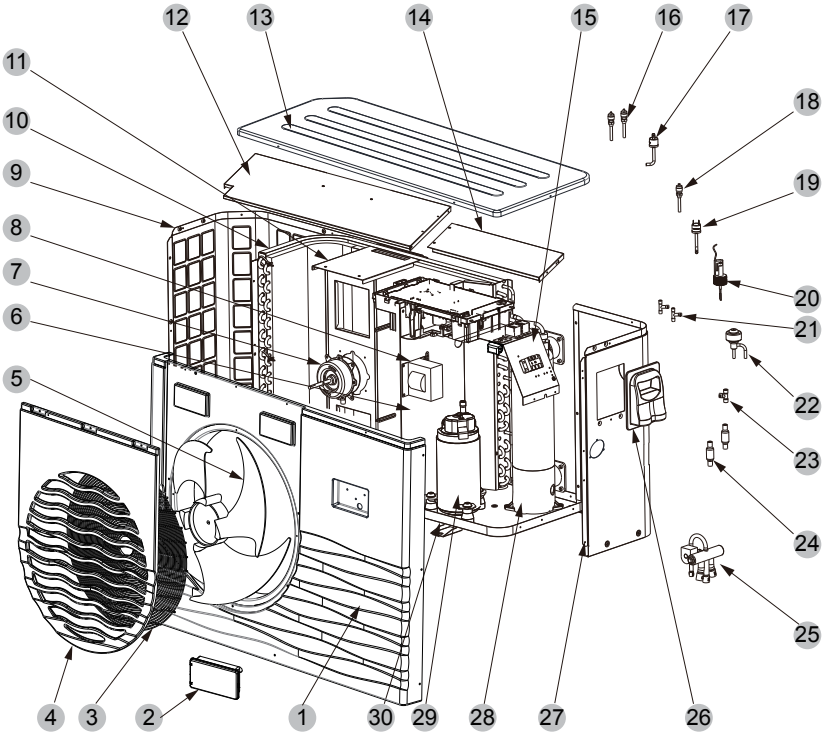

2 Electrical control structure explosion diagram

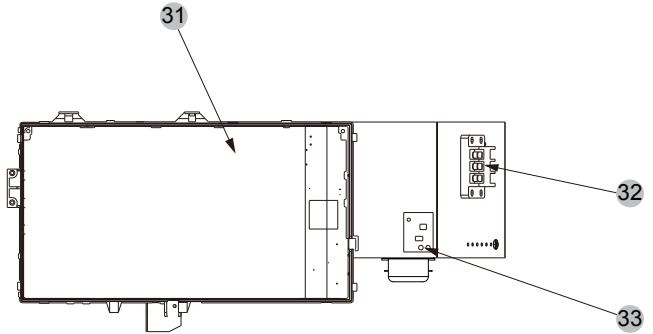

No.	Code	Name	Specifications	Qty
1	80900335	Front frame	ABS	1
2	95005-310500	CP302	20000-430176+35005-310500	1
3	32018-210143	network	Stainless steel	1
4	80900081	Fan protection net	ABS	1
5	20000-270004	Axial Flow Fan Blade	Z500-145	1
6	80700324	Middle Plate	Galvanized plate	1
7	20000-330132	DC Motor	ZWS75-A	1
8	82500005	Reactor	R2050FNKZ 20A 50Hz 5.2mH	1
9	80700323	Back Net	Galvanized sheet	1
10	80600079	Finned Tube Heat Exchanger	714×353×800×Φ7×2.2.0	1
11	80700329	Motor Bracket	Galvanized plate	1
12	80700327	Support Plate	Galvanized plate	1
13	80900623	Top cover	ABS	1
14	80700701	Top Support Plate 2	Galvanized plate	1
15	80701513	Electric Box Scaleboard	Galvanized plate	1
16	20000-140150	Needle Valve	40mm 1/2"	2
17	20000-360157	Pressure Switch	0.30MPa/0.15MPa ±0.05 NO	1
18	20000-140512	Needle valve	95mm 7/16"	1
19	2001-3605	Pressure switch	3.2MPa/4.4MPa ±0.15 NC	1
20	83000068	Water Switch (Mould Opening)	PSL-1 3/4	1
21	2000-1460	Three-way Connection	Φ6.5-2×Φ6.5(T)×0.75 T2M	2
22	81000017	Electronic Expansion Valve	DPF(TS1)2.0C-03 (TS120C03)	1
23	304030-00000002	Three-way Connection	Φ9.52-2×Φ6.35(T)×1.0	1
24	2004-1444	Filter	Φ9.7-Φ9.7 (Φ28) T2Y2	2
25	2004-1437	Four-way Valve	SHF-9H-35U-P/C03C01S	1
26	32009-220029	Wiring Box	ABS	1
27	80700322	Right Panel	Galvanized plate	1
28	80600097	Titanium Heat Exchanger	Φ12.7×12m Φ160	1
29	80100046	Compressor	SVB220FLGMC-L	1
30	80700321	Chassis	Galvanized plate	1
31	72200015	Controller	82300007+82400021	1
32	2000-3928	3-Position Wire Holder	RS9101(450V~ 4mm ²)(L, N, PE)	1
33	82600008	Switching power supply	EPS-15-12	1

7.3 Explosive view of the unit

Model and code:(Thermotec Inverter 20kw)

1 Complete machine structure explosion diagram

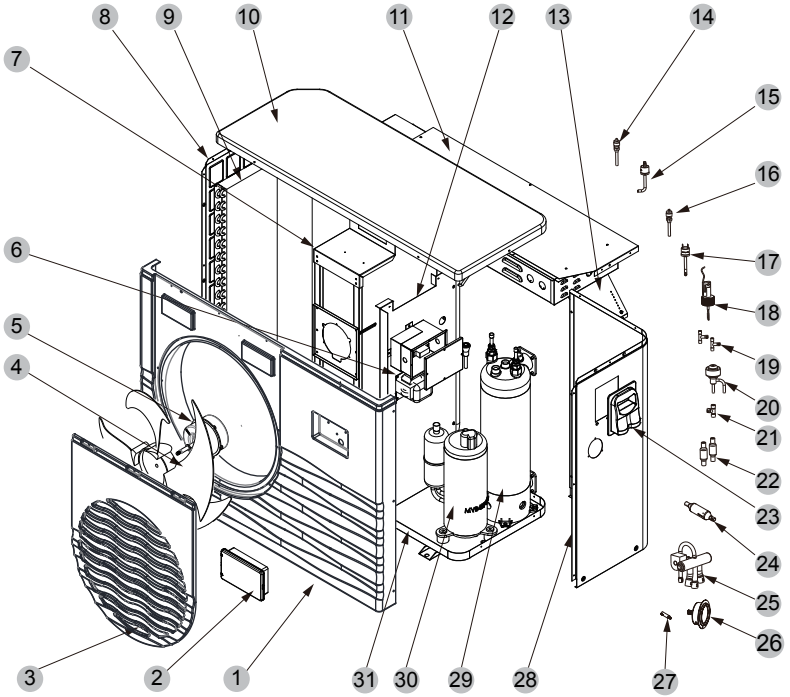

2 Electrical control structure explosion diagram

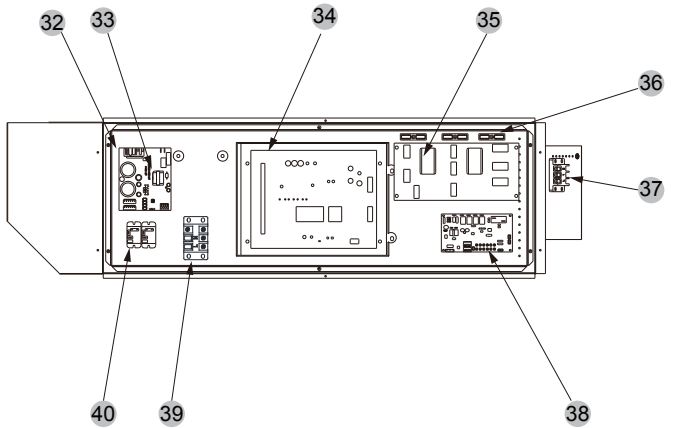

No.	Code	Name	Specifications	Qty
1	80900335	Front frame	ABS	1
2	95005-310500	CP302	20000-430176+35005-310500	1
3	80900081	Fan protection net	ABS	1
4	20000-270004	Axial flow fan blades	Z500-145	1
5	20000-330132	Dc motor	ZWS75-A	1
6	20000-370030	Frequency converter reactor	R3005RJC-1	1
7	80700330	Motor Bracket	Galvanized plate	1
8	80702268	After the network	Galvanized plate	1
9	80600079	Finned heat exchanger	714×353×800×Φ7×2 2.0	1
10	80900346	Top cover	ABS	1
11	301070-20090003	Electrical lifted the lid	Galvanized plate	1
12	80700325	Partition	Galvanized plate	1
13	301070-20090002	Electrical box	Galvanized plate	1
14	20000-140150	Needle Valve	40mm 1/2"	2
15	20000-360157	Pressure switch	0.30MPa/0.15MPa ±0.05 NO	1
16	20000-140512	Needle Valve	95mm 7/16"	1
17	2001-3605	Pressure switch	3.2MPa/4.4MPa ±0.15 NC	1
18	83000069	Water Switch (Mould Opening)	PSL-1 3/4	1
19	2000-1460	Three-way Connection	Φ6.5-2×Φ6.5(T)×0.75 T2M	3
20	20000-140450	Electronic Expansion Valve	DPF(TS1)2.0C-03 (TS120C03)	1
21	2000-1435	Three-way Connection	Φ9.7-2×Φ9.7(T)×1.0 T2M	2
22	2004-1444	Filter	Φ9.7-Φ9.7 (Φ28) T2Y2	2
23	32009-220029	Wiring Box	ABS	1
24	2001-1499	Check Valve	PKV-6X1	1
25	2001-1491	Four-way Valve	SHF-20A-46/DSF-20-R410A	1
26	81900044	Pressure gauge	0-55Kg/cm2	1
27	20000-140142	Get straight through	Φ9.52-Φ3.8×0.75 T2M	2
28	80702267	Right side of the plate	Galvanized sheet	1
29	80600098	Titanium tube heat exchanger	Φ16×7.3m+Φ12.7×5.7m	1
30	301010-00000006	Compressor	MVB42FCBMC-L	1
31	80702266	Chassis	Galvanized plate	1
32	301070-20090007	Electrical box liner	Galvanized plate	1

7.3 Explosive view of the unit

Model and code:(Thermotec Inverter 24kw)

1 Complete machine structure explosion diagram

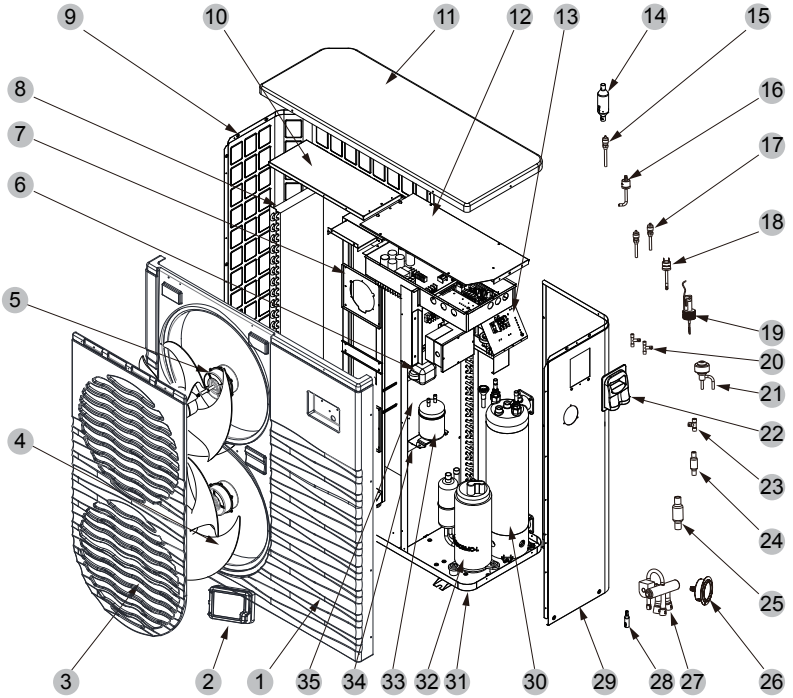

2 Electrical control structure explosion diagram

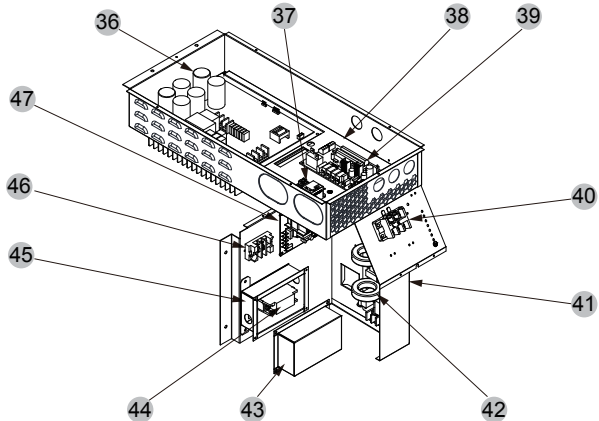

No.	Code	Name	Specifications	Qty
1	80900336	Front Panel	ABS	1
2	95005-310500	CP302	20000-430176+35005-310500	1
3	32019-210065	Fan protection net	ABS	1
4	20000-270004	Axial Flow Fan Blade	Z500-145	2
5	20000-330132	Dc motor	ZWS75-A	2
6	20000-370030	Converter reactor	R3005RJC-1	1
7	80700399	Motor Bracket	Galvanized plate	1
8	80600111	Finned Tube Heat Exchanger	714×353×1200×Φ7×2 2.0	1
9	80700397	Back Net	Galvanized plate	1
10	80700400	Top Support Plate	Galvanized plate	1
11	80900076	Top cover	ABS	1
12	80700407	Electric Box Cover	Galvanized plate	1
13	80702289	Electric Box	Galvanized plate	1
14	2001-1499	Check Valve	PKV-6X1	1
15	20000-140512	Needle valve	95mm 7/16"	1
16	20000-360157	Pressure switch	0.30MPa/0.15MPa ±0.05 NO	1
17	20000-140150	Needle valve	40mm 1/2"	2
18	2001-3605	Pressure switch	3.2MPa/4.4MPa ±0.15 NC	1
19	83000069	Water flow switch	PSL-1 3/4	1
20	2000-1460	There-way valve	Φ6.5-2×Φ6.5(T)×0.75 T2M	3
21	20000-140401	Electronic Expansion Valve	DPF(TS1)3.0C-01 (TS130C01)	1
22	32009-220029	Junction box body	ABS	1
23	2000-1435	There-way valve	Φ9.7-2×Φ9.7(T)×1.0 T2M	2
24	2004-1444	Filter	Φ9.7-Φ9.7 (Φ28) T2Y2	1
25	20000-140027	Filter	Φ12.9-Φ12.9(Φ28) T2Y2	1
26	81900044	Pressure gauge	0-55Kg/cm2	1
27	2001-1491	Four-way valve	SHF-20A-46/V6-412080-1XX	1
28	20000-140143	Get straight through	Φ9.52-Φ4.2×0.75 T2M	2
29	80700396	Right side of the plate	Galvanized plate	1
30	80600115	Titanium tube heat exchanger	Φ16×7.9m+Φ12.7×6.1m	1
31	80700395	Chassis	Galvanized plate	1
32	301010-00000006	Compressor	MVB42FCBMC-L	1
33	20000-140579	Storage tank	TY-20-SX	1

7.3 Explosive view of the unit

Model and code:(Thermotec Inverter TRI 24kw)

1 Complete machine structure explosion diagram

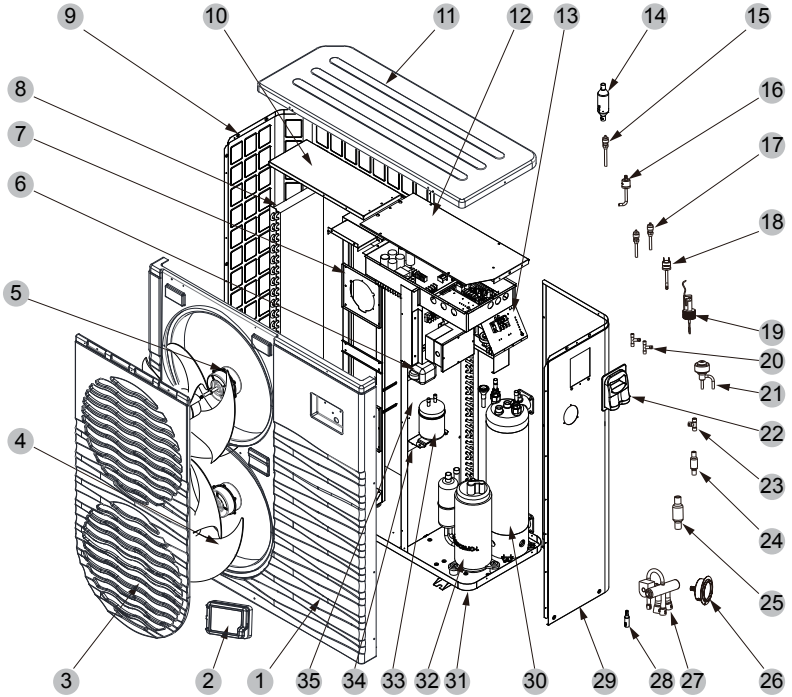

2 Electrical control structure explosion diagram

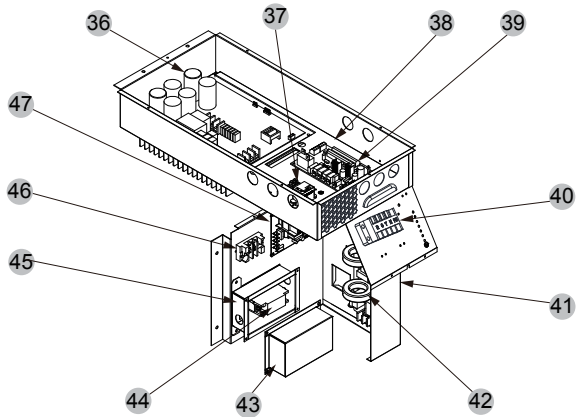

No.	Code	Name	Specifications	Qty
1	80900336	Front Panel	ABS	1
2	95005-310500	CP302	20000-430176+35005-310500	1
3	32019-210065	Fan protection net	ABS	2
4	20000-270004	Axial Flow Fan Blade	Z500-145	2
5	20000-330132	Dc motor	ZWS75-A	2
6	20000-370030	Converter reactor	R3005RJC-1	1
7	80700399	Motor Bracket	Galvanized plate	1
8	80600111	Finned Tube Heat Exchanger	714×353×1200×Φ7×2 2.0	1
9	80700397	Back Net	Galvanized plate	1
10	80700400	Top Support Plate	Galvanized plate	1
11	80900623	Top cover	ABS	1
12	80700407	Electric Box Cover	Galvanized plate	1
13	80700409	Electric Box	Galvanized plate	1
14	2001-1499	Check Valve	PKV-6X1	1
15	20000-140512	Needle valve	95mm 7/16"	1
16	20000-360157	Pressure switch	0.30MPa/0.15MPa ±0.05 NO	1
17	20000-140150	Needle valve	40mm 1/2"	2
18	2001-3605	Pressure switch	3.2MPa/4.4MPa ±0.15 NC	1
19	83000069	Water flow switch	PSL-1 3/4	1
20	2000-1460	There-way valve	Φ6.5-2×Φ6.5(T)×0.75 T2M	3
21	20000-140401	Electronic Expansion Valve	DPF(TS1)3.0C-01 (TS130C01)	1
22	32009-220029	Junction box body	ABS	1
23	2000-1435	There-way valve	Φ9.7-2×Φ9.7(T)×1.0 T2M	2
24	2004-1444	Filter	Φ9.7-Φ9.7 (Φ28) T2Y2	1
25	20000-140027	Filter	Φ12.9-Φ12.9(Φ28) T2Y2	1
26	81900044	Pressure gauge	0-55Kg/cm2	1
27	2001-1491	Four-way valve	SHF-20A-46/V6-412080-1XX	1
28	20000-140143	Get straight through	Φ9.52-Φ4.2×0.75 T2M	2
29	80700396	Right side of the plate	Galvanized plate	1
30	80600115	Titanium tube heat exchanger	Φ16×7.9m+Φ12.7×6.1m	1
31	80700395	Chassis	Galvanized plate	1
32	301010-00000006	Compressor	MVB42FCBMC-L	1
33	20000-140579	Storage tank	TY-20-SX	1

Contact details

HeatPumps4Pools Ltd
Unit 5, Radford Business Centre
Radford Crescent
Billericay
Essex
CM12 0DP
United Kingdom

Tel +44 1268 206560

www.HeatPumps4Pools.com

enquiries@heatpumps4pools.com



TM



We reserve the right to change all or part of the contents of this document without prior notice

Code:20181029-0001