

# MasterTrack BT Synchro

Montageanleitung · Instruction Manual · Instructions d'installation · Instrucciones de instalación · Istruzioni per l'installazione · Szerelési útmutató · Monteringsanvisning · Installatie-instructies · Инструкция по монтажу

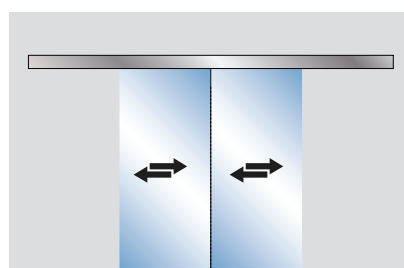

65 / 80 / 120 kg  
143 / 176 / 265 lbs

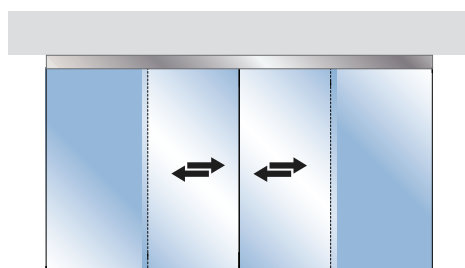
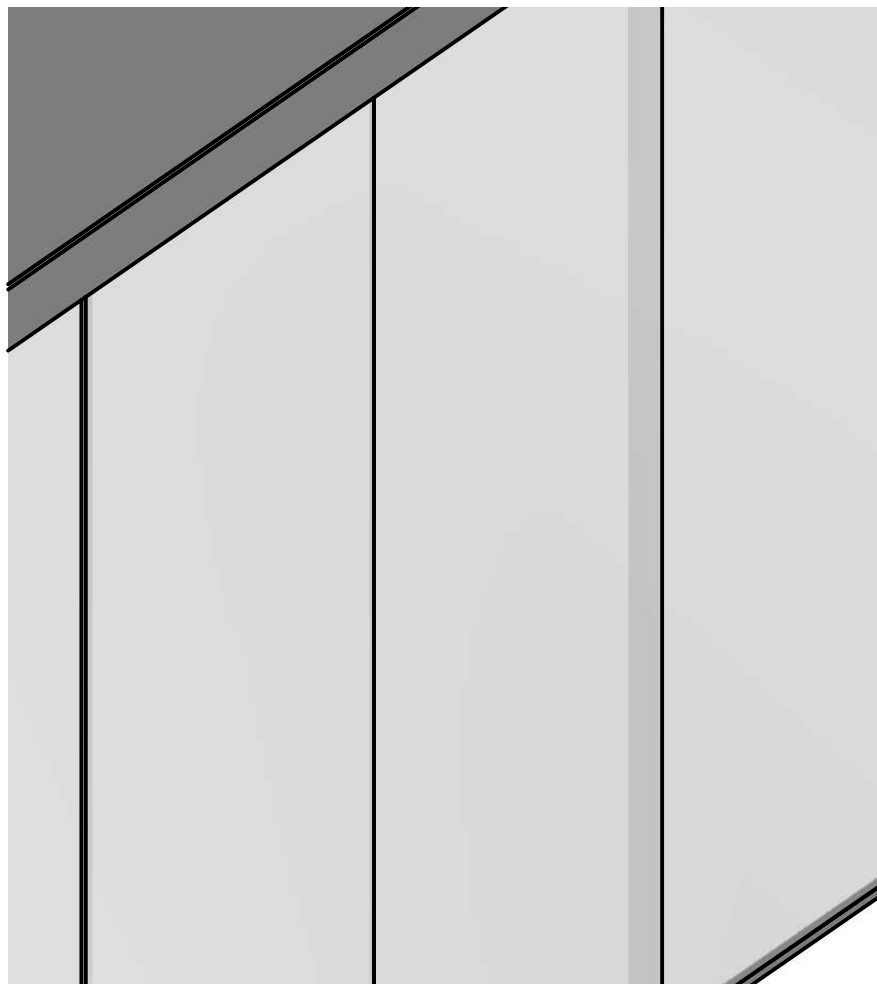
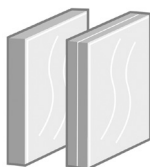

8 - 10 mm  
max 1/2 "

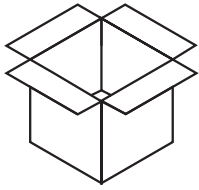

# MasterTrack BT Synchro



BO 5800001

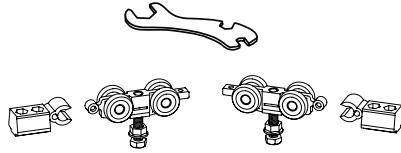

BO 5800002

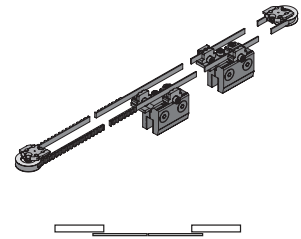
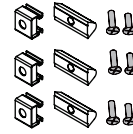

BO 5800002



## Optional Components

←← 65 kg (143 lbs)

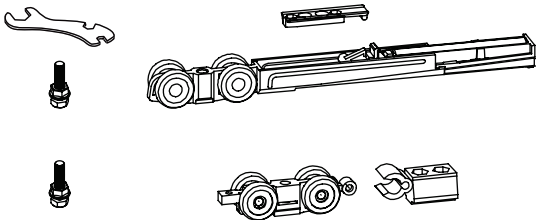

BO 5800060 + BO 5800002

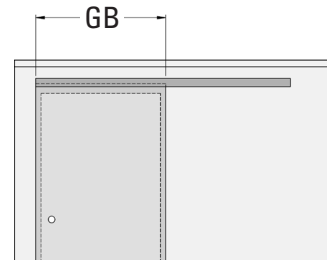

GB = min. 580 mm

←← 80 kg (173 lbs)

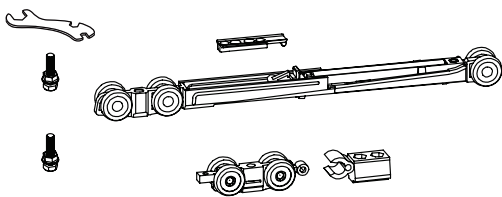

BO 5800080 + BO 5800002

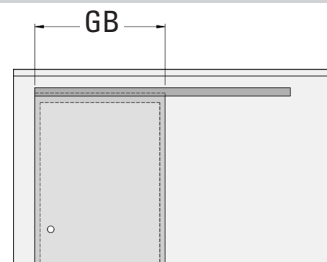

GB = min. 640 mm

←← 130 kg (286 lbs)

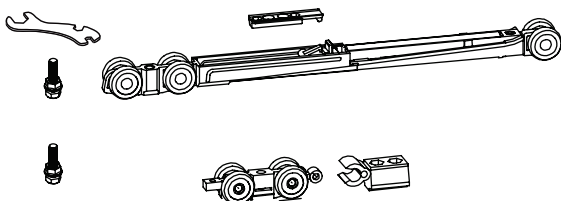

BO 5800120 + BO 5800002

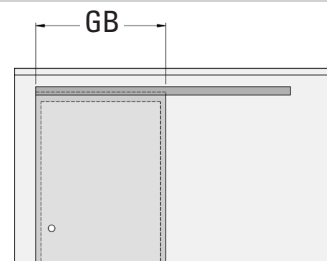

GB = min. 700 mm



BO 5802011 / BO 5803011 / BO 5804011 / BO 5806011	BO 5802031	BO 5802041 / BO 5803041 / BO 5804041 / BO 5806041	BO 6703434 / BO 6703446
			Optional

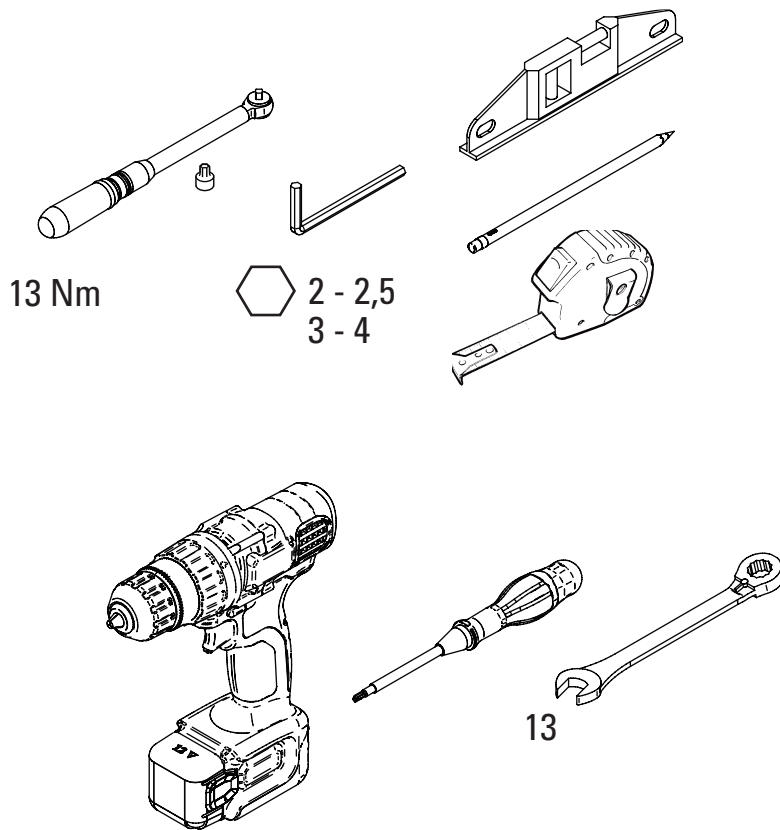

Die Glasscheiben und Profile vor der Installation reinigen  
*Clean the glass and profiles before installing*

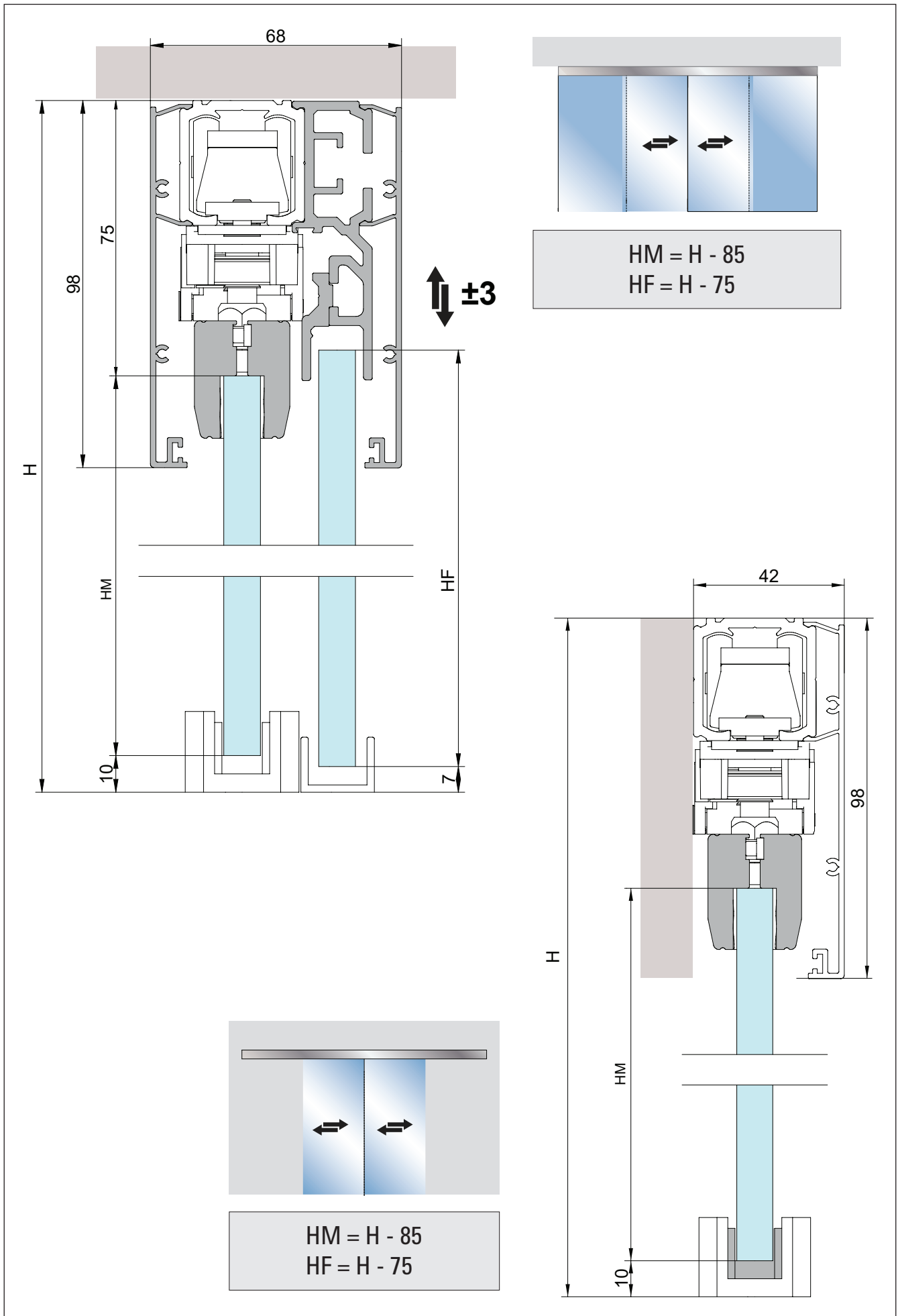

01

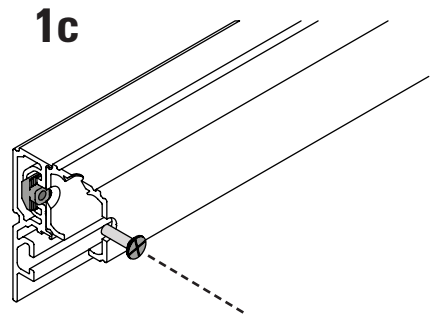
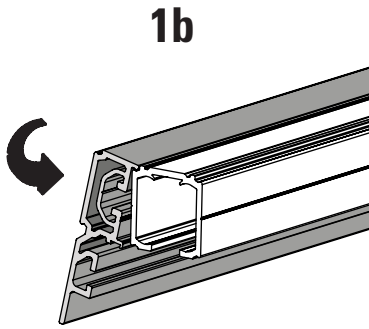
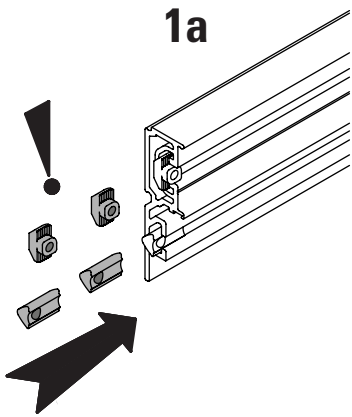
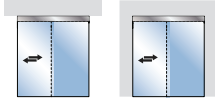

Laufschiene in das Festverglasungsprofil klicken.  
Bei Wandmontage - Seite 7 beachten.

*Clip top track and fixed glass profile with the cage nut.  
With wall assembly - Watch page 7*

02

OPTIONAL

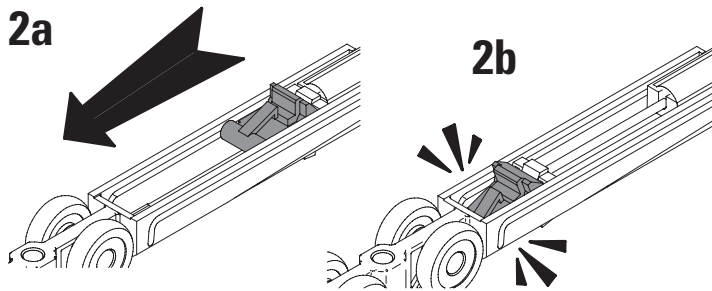

Den Haken von Position 2a zu  
Position 2b drücken bis es klickt.  
*Press the hook from position 2a to  
2b since it clicks.*

03

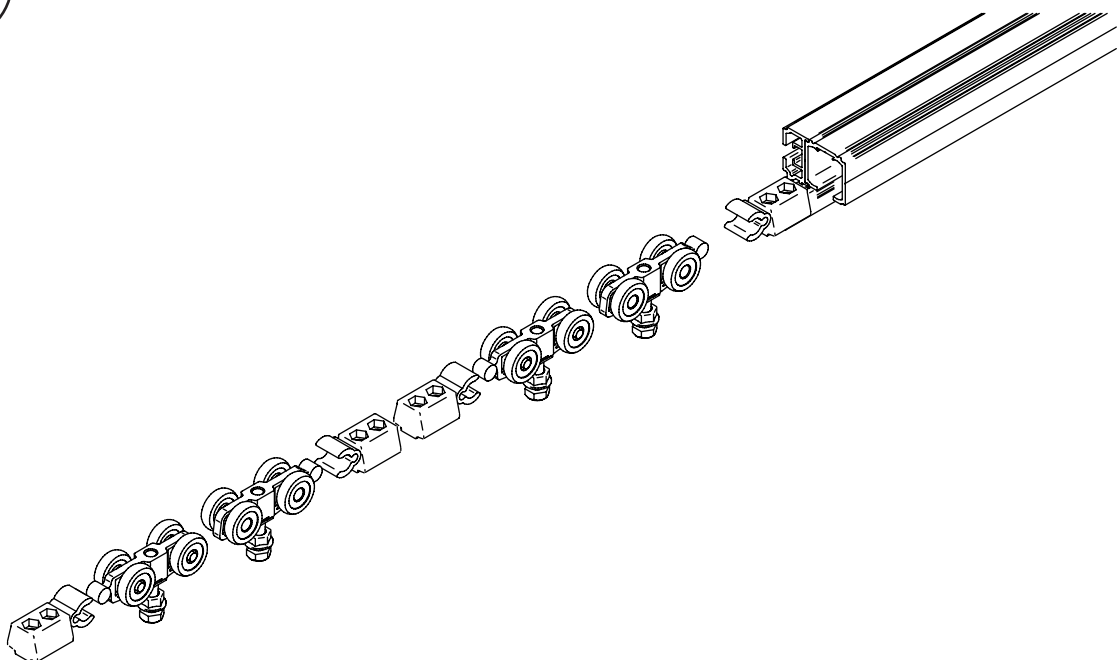

03

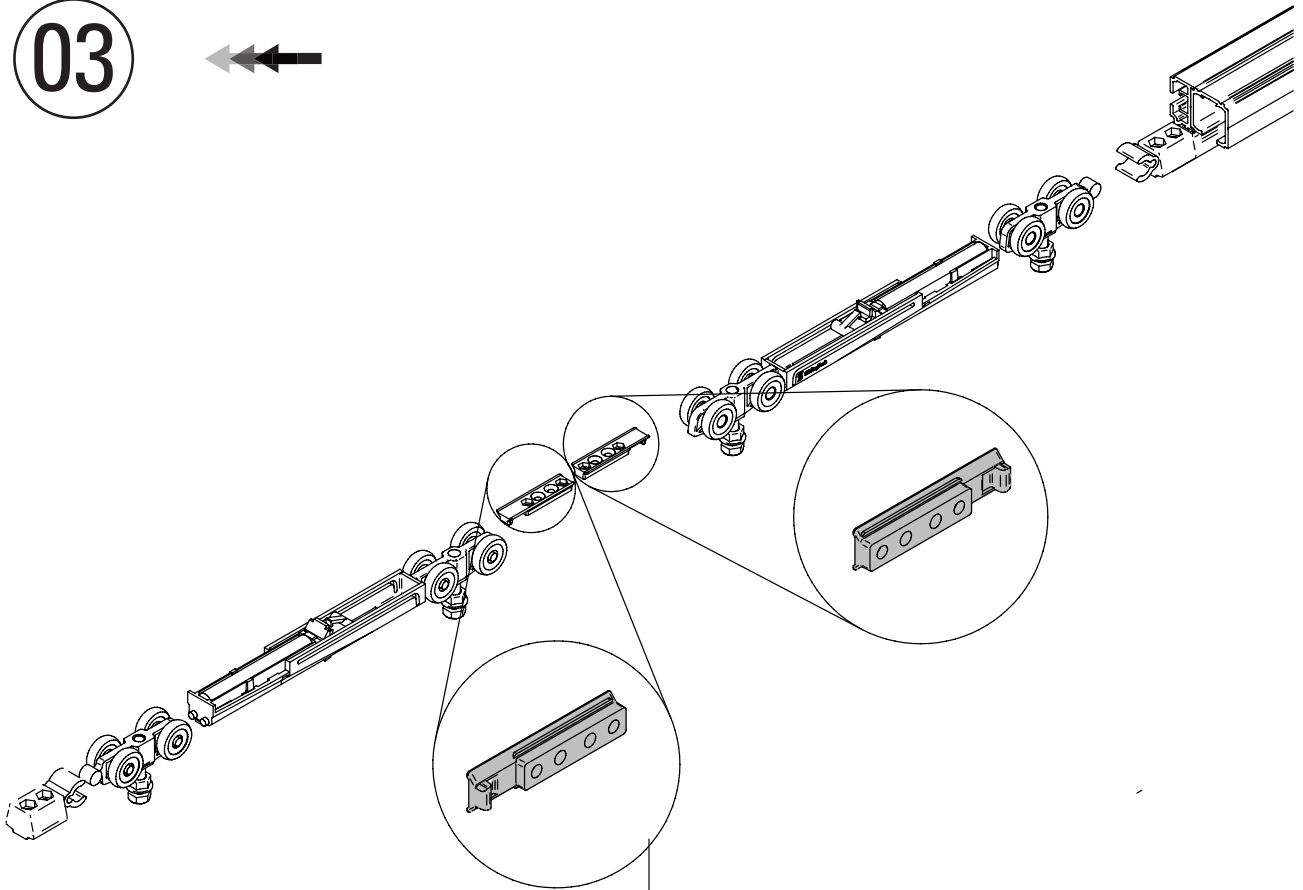

04

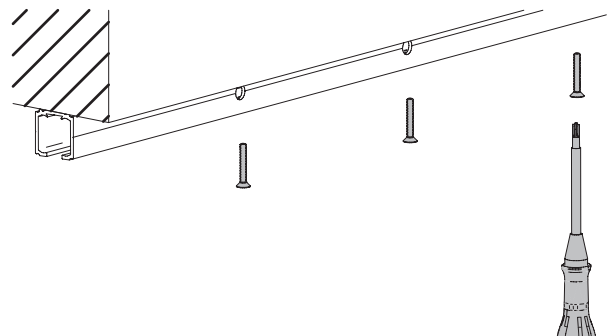
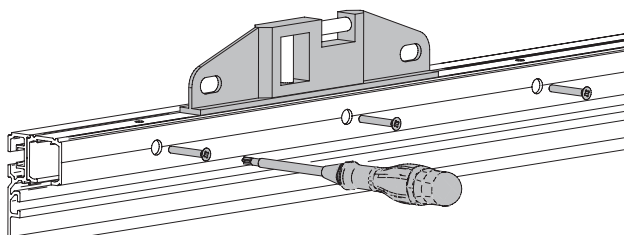
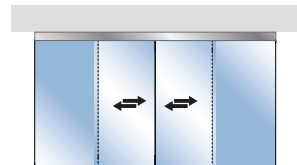
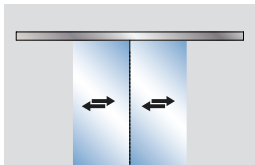

Bei Wandmontage die Käfigmutter nicht einsetzen.  
*With wall assembly DO NOT insert cage nut.*

05

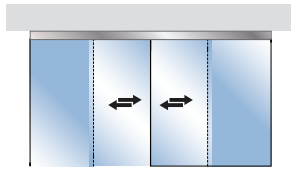

Montage Festverglasung  
Assembly fixed glass

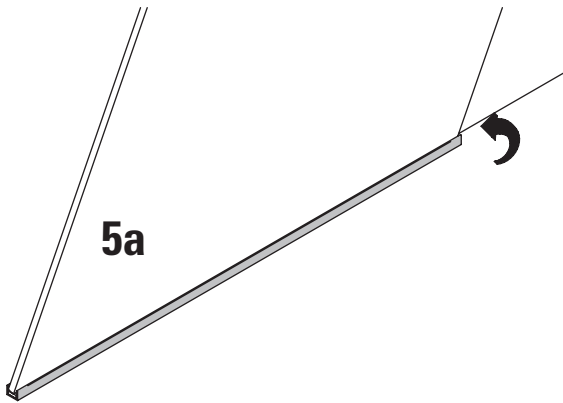

5a

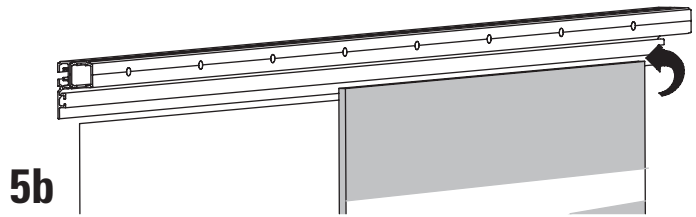

5b

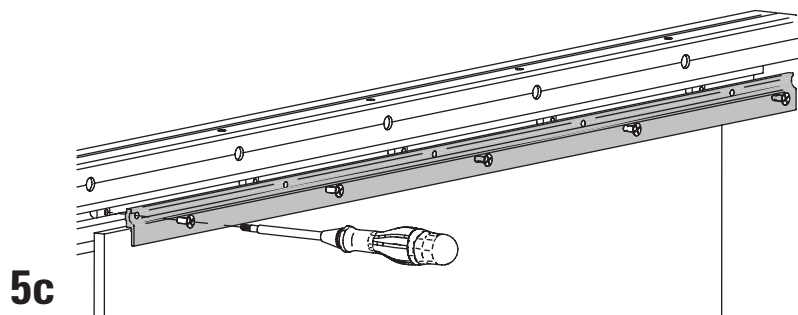

5c

06

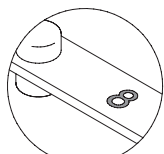

8 mm

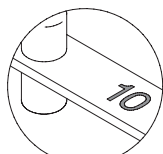

10 mm

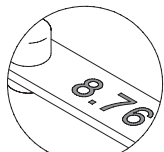

8,76 mm

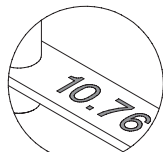

10,76 mm

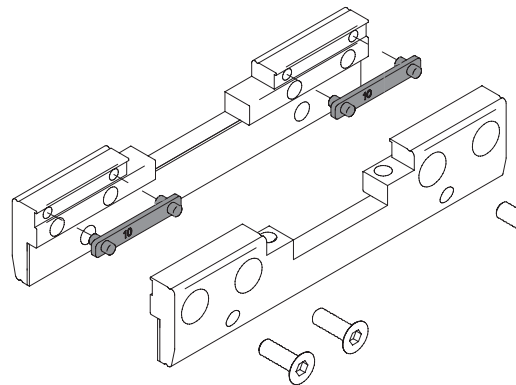

07

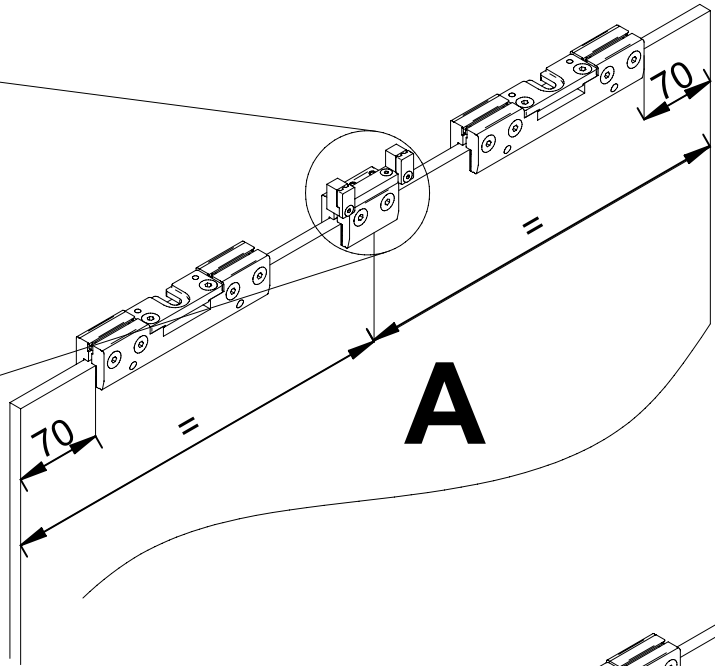
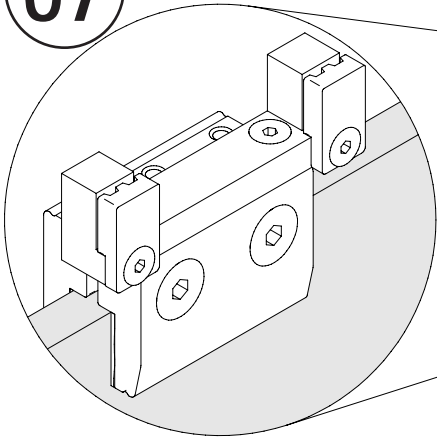

08

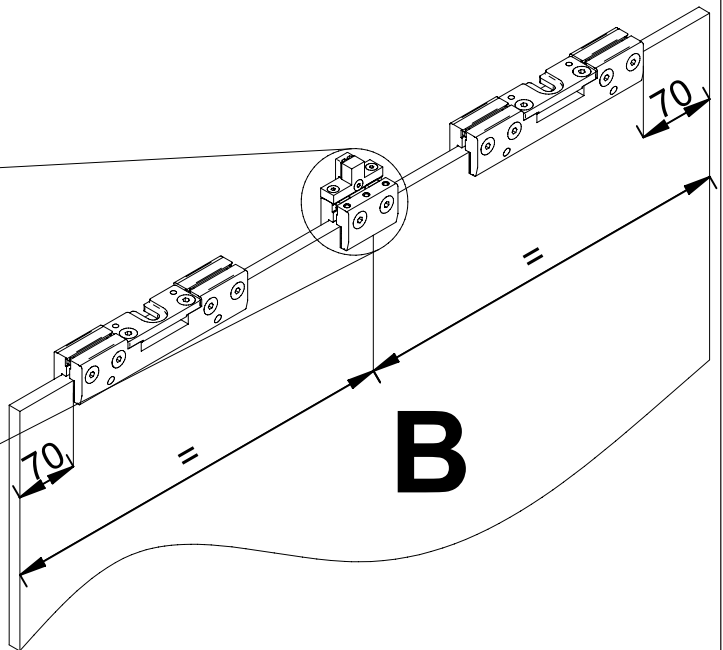
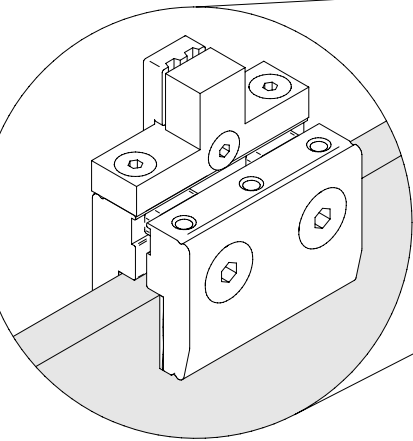

09

Die 3 Konterplatten an diesen Stellen in dem Profil einsetzen  
 Insert in the top track the 3 counterplate as showns

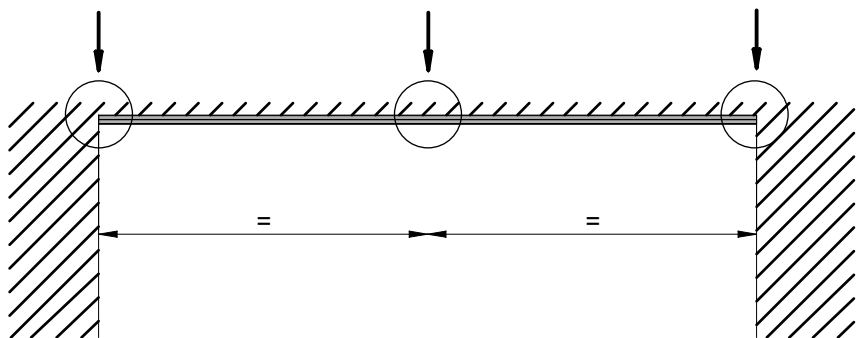
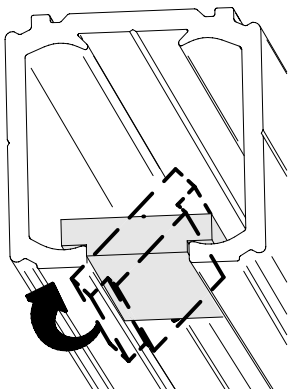

10

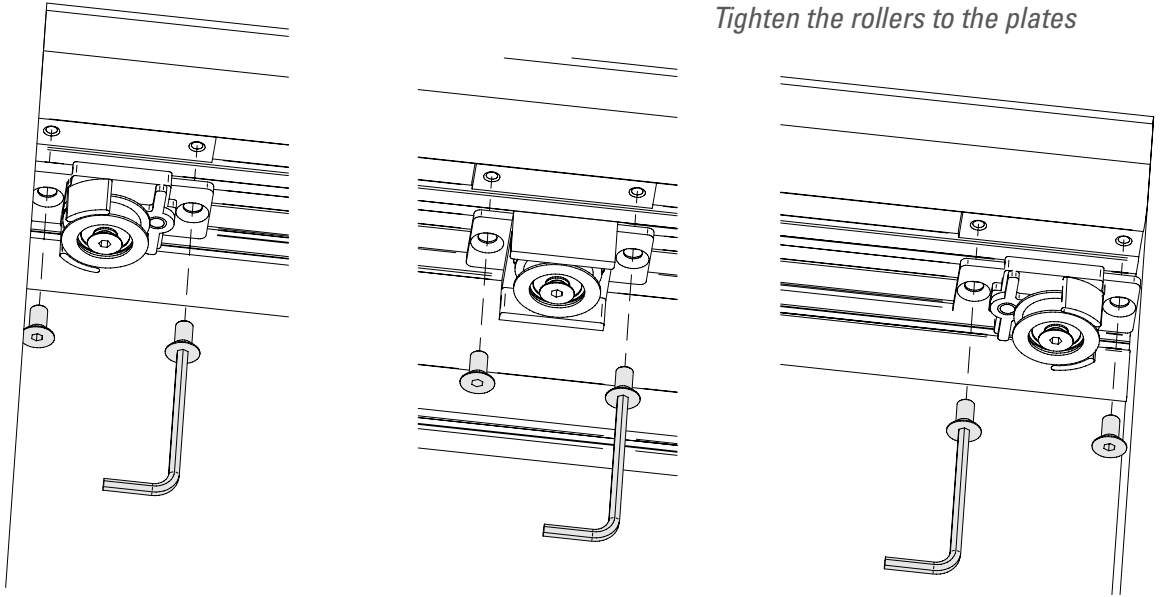

Die Rollen im Profil befestigen  
*Tighten the rollers to the plates*

11

Türen montieren  
*Door assembly*

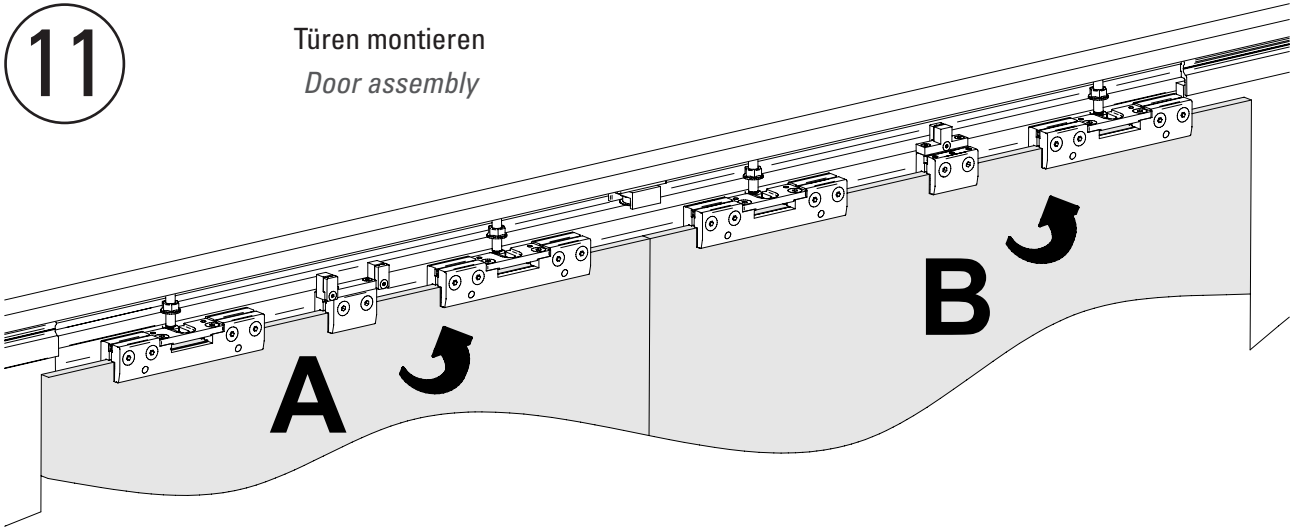

12

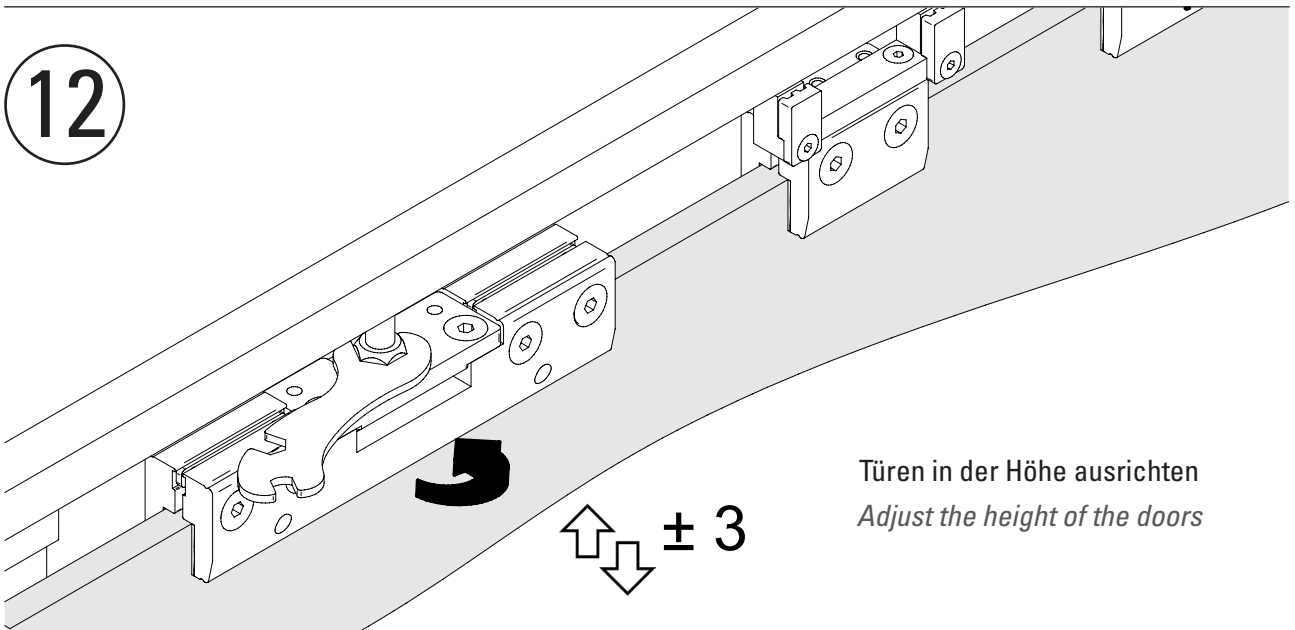

Türen in der Höhe ausrichten  
*Adjust the height of the doors*

13

Den Zahnriemen installieren  
*Fit the toothed belt*

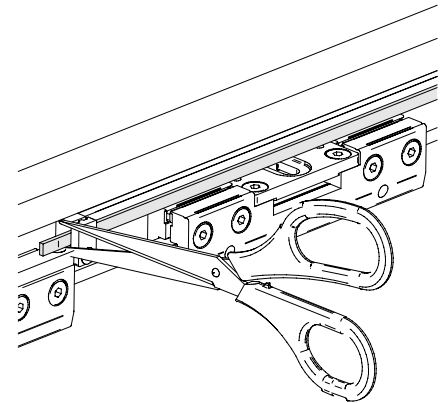
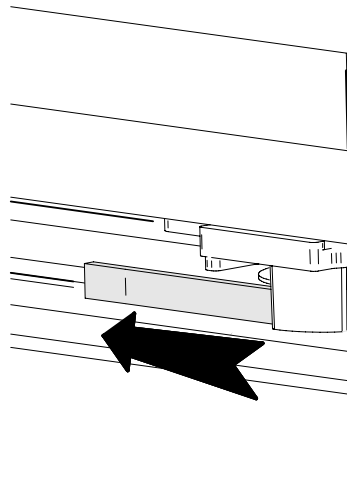
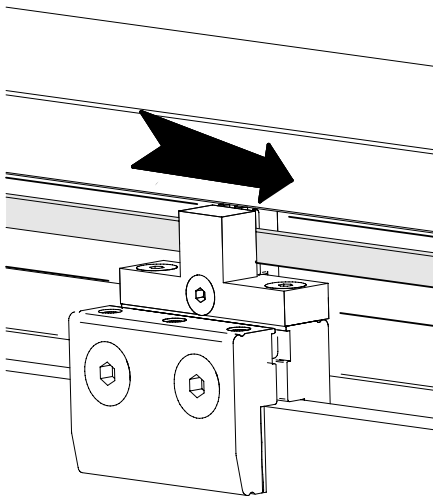
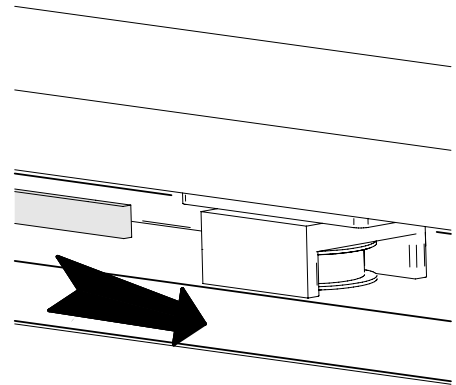
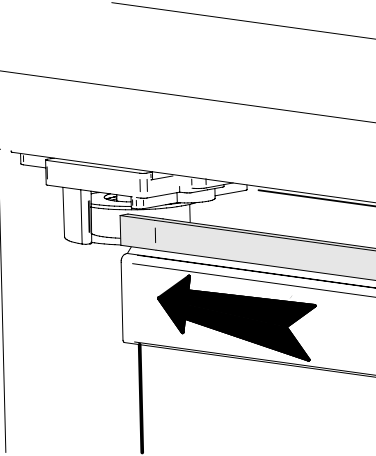
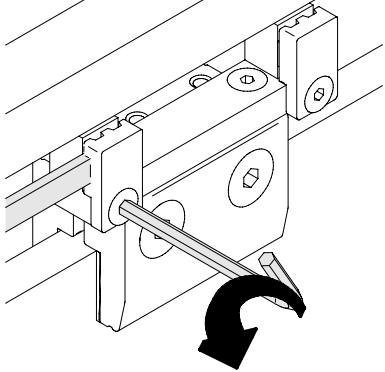

Schneiden Sie den Überschuss ab  
*Cut the excess*

14

Stellen Sie die Türen ein. Schließen Sie sie. Ziehen Sie die Schrauben fest  
*Adjust the doors. Close them. Tighten the screws*

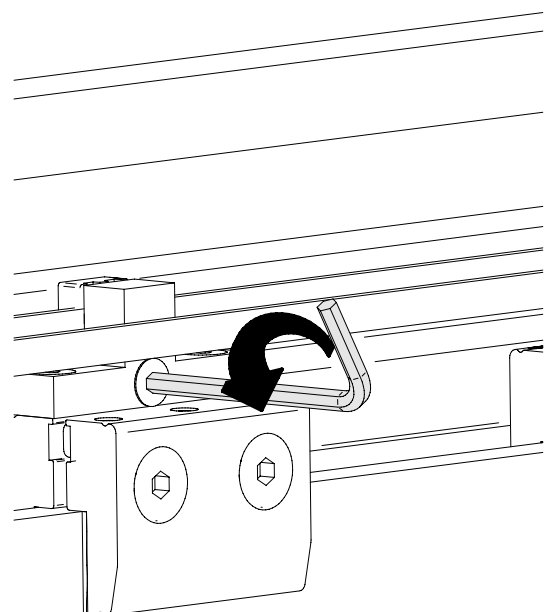
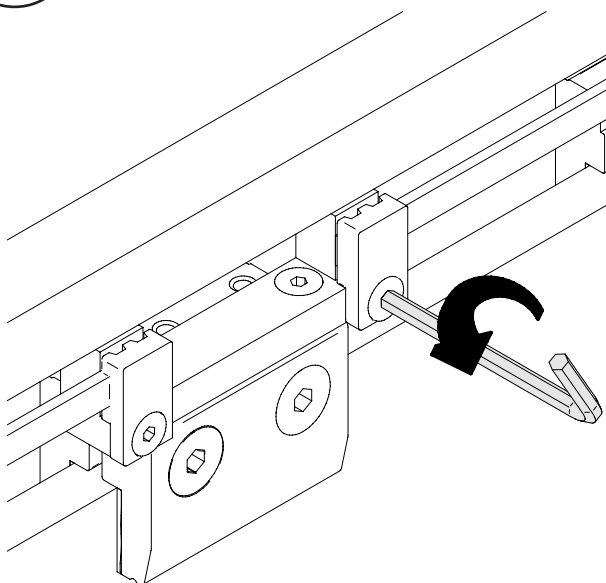



# Bohle Worldwide

## Germany

Bohle AG  
42781 Haan  
T +49 2129 5568-100  
info@bohle.de

## Austria | Hungary Slovenia

Bohle GmbH  
1230 Wien  
T +43 1 804 4853-0  
info@bohle.at

## Benelux

Bohle Benelux B.V.  
3905 LX Veenendaal  
T +31 318 553151  
info@bohle.nl

## China

Bohle Trading Co., Ltd  
Tianhe District, Guangzhou  
T +86-20-38105870  
jiang.du@bohle.de

## Croatia

Bohle d.o.o.  
51000 Rijeka  
T +385 051-329-566  
info@bohle.hr

## Estonia

Bohle Baltic  
13619 Tallinn  
T +372 6112-826  
info@bohle.ee

## France

Bohle AG · Departement Français  
42781 Haan, Germany  
T +49 2129 5568-222  
france@bohle.de

## Italy

Bohle Italia s.r.l.  
20080 Vermezzo (MI)  
T +39 02 94967790  
info@bohle.it

## Russia

Bohle Москва  
108811 Москва  
T +7 495 230-94-00  
info@bohle.ru

## Russia

Bohle Санкт Петербург  
198020 Санкт Петербург  
T +7 812 4452792  
info@bohle.spb.ru

## Spain | Portugal

Bohle Complementos del Vidrio S.A.U.  
E - 08029 Barcelona  
T +34 932 615 361  
info@bohle.es

## South Africa

Bohle Glass Equipment (Pty) Ltd.  
2125 Gauteng  
T +27 11 792-6430  
info@bohle.co.za

## Sweden

Bohle Scandinavia AB  
14175 Kungens Kurva  
T +46 8 449 57 50  
info@bohle.se

## United Kingdom

Bohle Ltd.  
Dukinfield, Cheshire, SK16 4PP  
T +44 161 3421100  
info@bohle.ltd.uk

## USA | Canada

Bohle America, Inc  
Charlotte, NC 28273  
T +1 704 247 8400  
info@bohle-america.com

Bohle AG  
Dieselstraße 10  
42781 Haan

T +49 2129 5568-100

info@bohle.de

Für Anliegen rund um das Beschlagsortiment:

@ [beschlag@bohle.de](mailto:beschlag@bohle.de)  
☎ 02129 5568 951

Für die Unterstützung bei der Projektplanung:

@ [technik-beschlag@bohle.de](mailto:technik-beschlag@bohle.de)  
☎ 02129 5568 953

For matters relating to the fittings range:

@ [hardware@bohle.de](mailto:hardware@bohle.de)  
☎ +49 (0) 2129 5568 951

For support with project planning:

@ [technical-hardware@bohle.de](mailto:technical-hardware@bohle.de)  
☎ 02129 5568 953

