

MasterTrack BT Teleskop -3-

Montageanleitung · Instruction Manual · Instructions d'installation · Instrucciones de instalación · Istruzioni per l'installazione · Szerelési útmutató · Monteringsanvisning · Installatie-instructies · Инструкция по монтажу

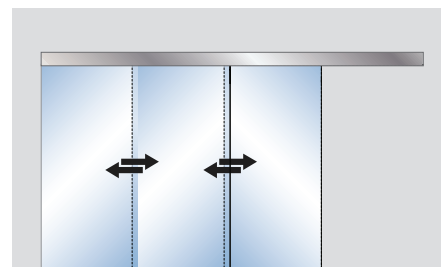

65 / 80 / 120 kg
143 / 176 / 265 lbs

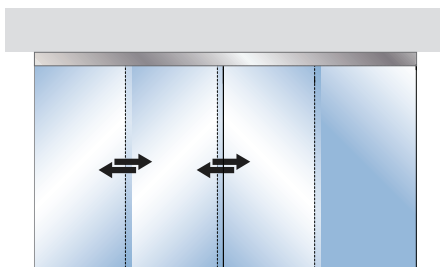
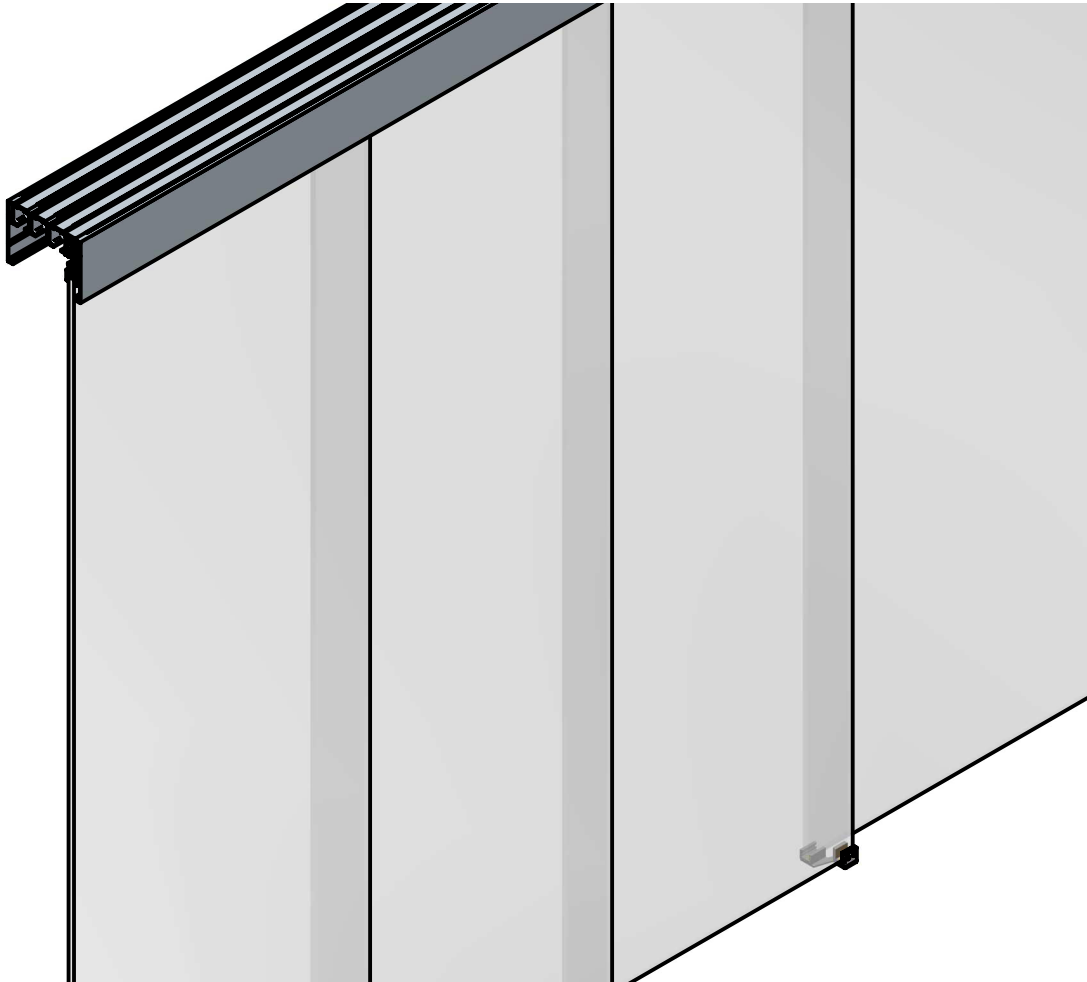
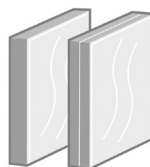

8 - 10 mm
max 1/2 "

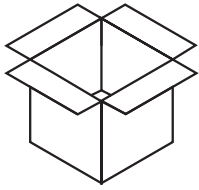

MasterTrack BT Teleskop -3-



BO 5800001

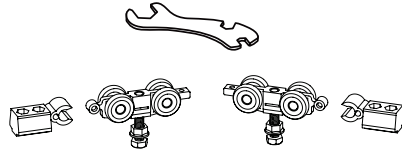

BO 5800002

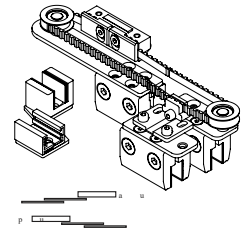
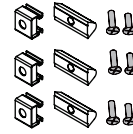

BO 5800007



Optional Components

←← 65 kg (143 lbs)

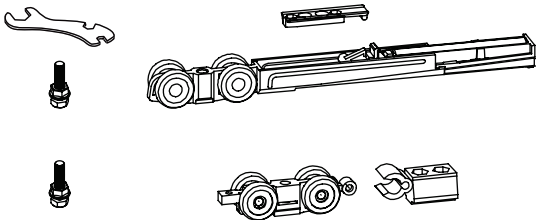

BO 5800060 + BO 5800002

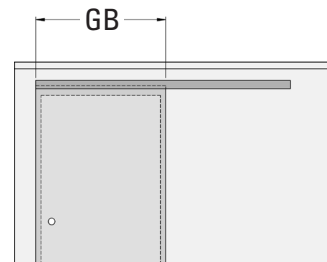

GB = min. 580 mm

←← 80 kg (173 lbs)

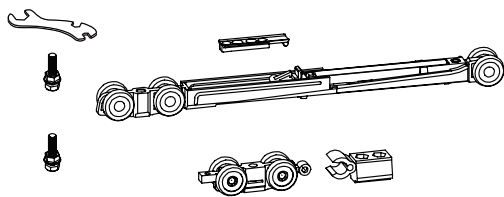

BO 5800080 + BO 5800002

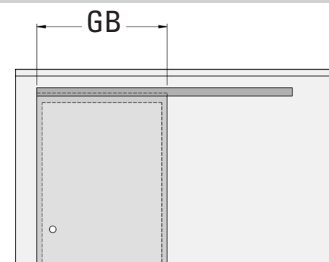

GB = min. 640 mm

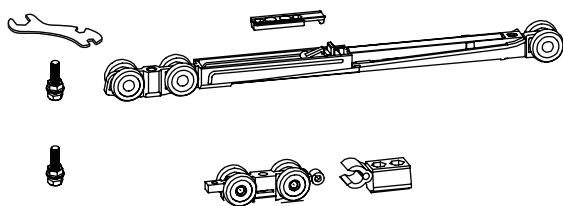

←← 130 kg (286 lbs)

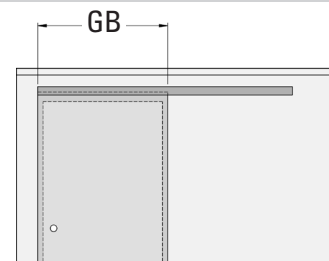

BO 5800120 + BO 5800002

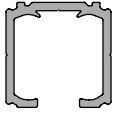
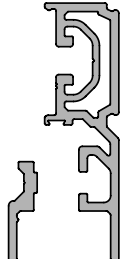

GB = min. 700 mm

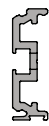
BO 5802011 / BO 5803011 / BO 5804011 / BO 5806011	BO 5802031	BO 5802041 / BO 5803041 / BO 5804041 / BO 5806041	BO 6703434 / BO 6703446	BO 5802061
			 Optional	

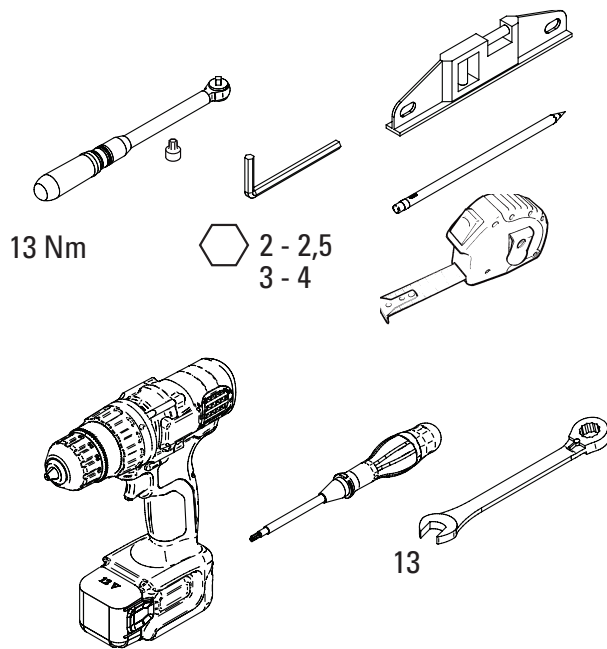

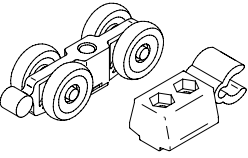
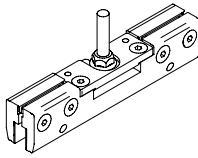
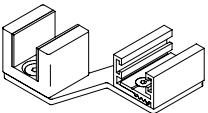
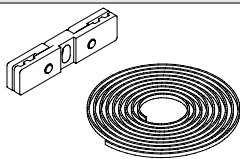
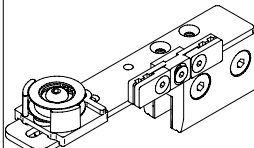
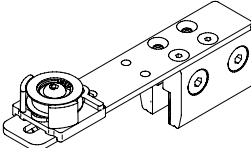
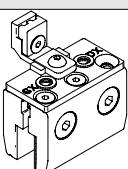
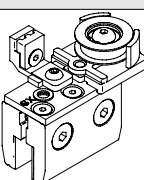
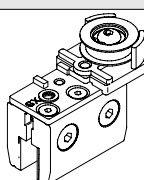
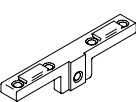
C		P0		GM	
					
S		P1		P2	
					
P3	P4	P5	B		
					

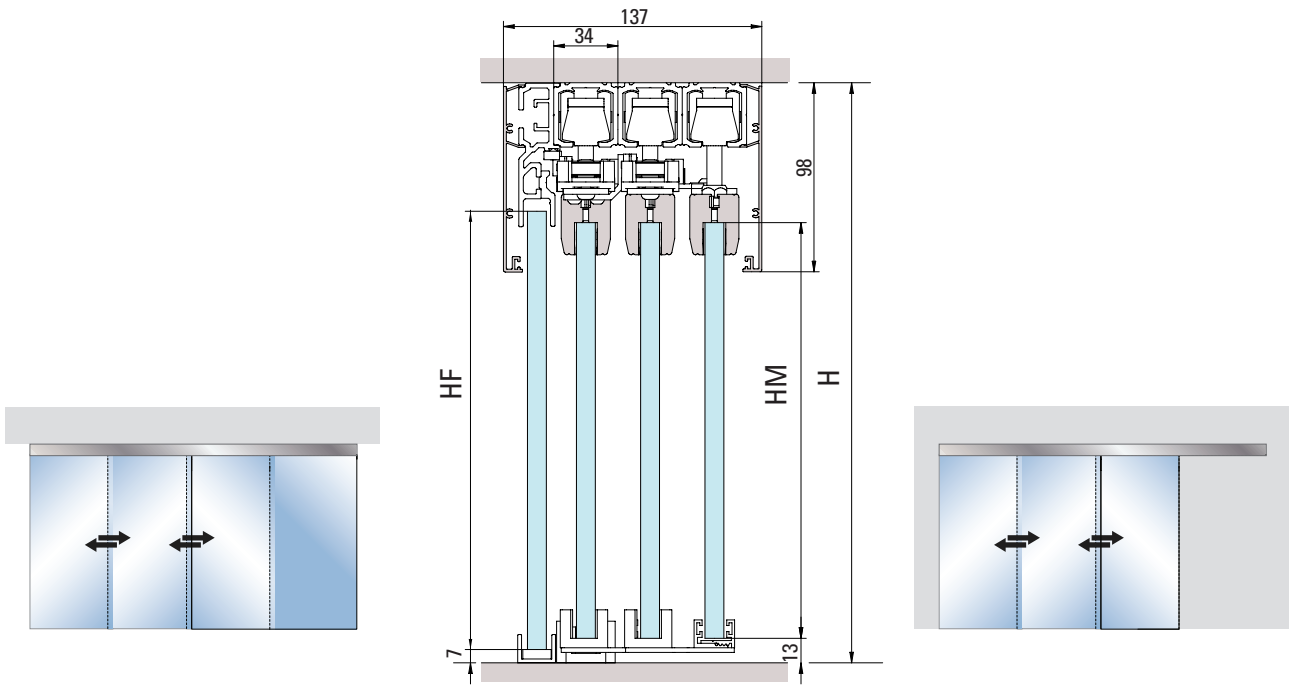

Bündige Montage · *Flush mounting*

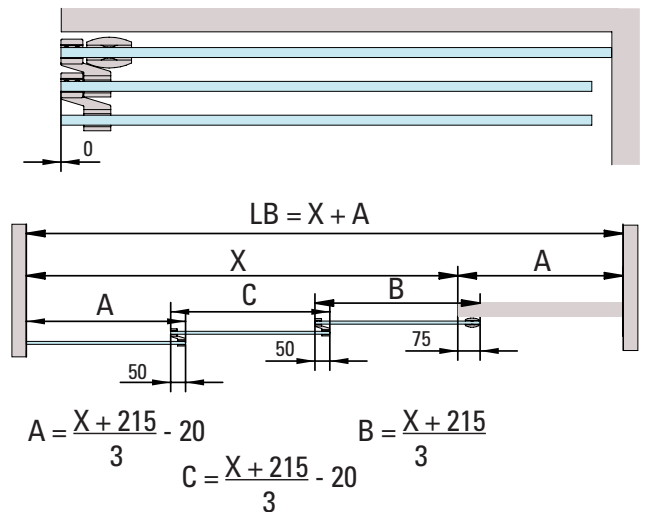
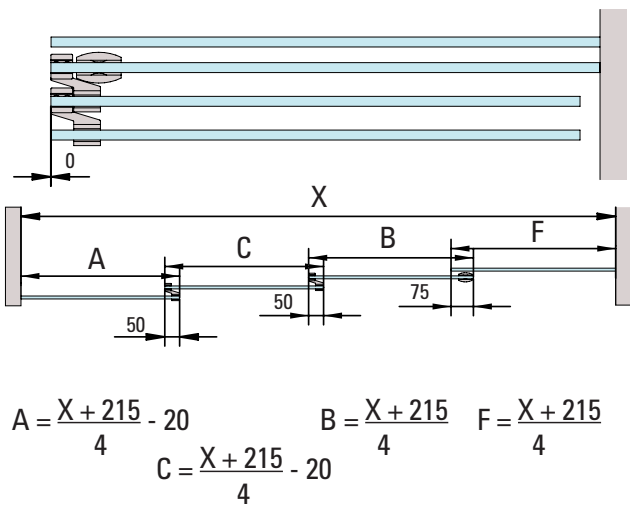

Bei der Verwendung eines Griffes · *In case of handle*

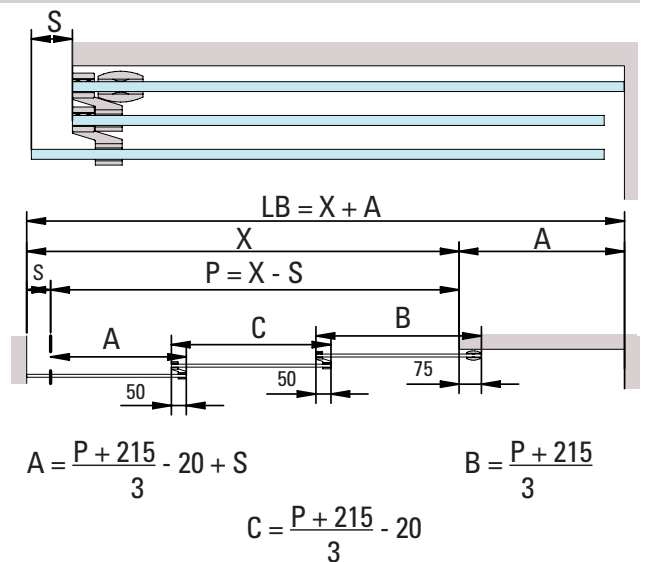
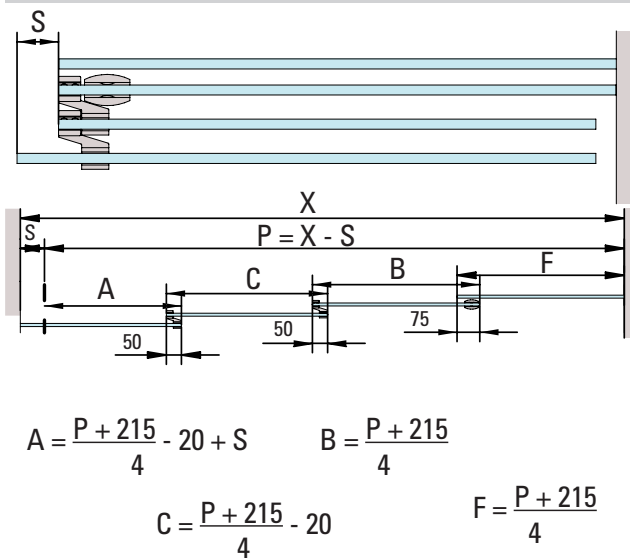

01

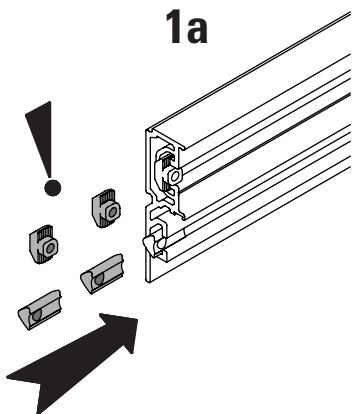

1b

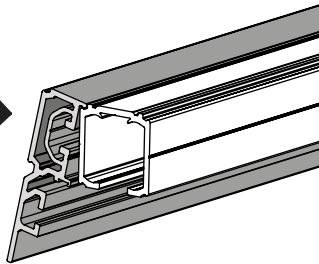

1c

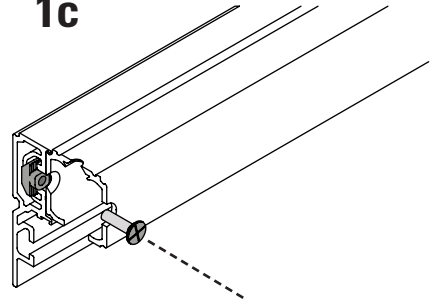

Laufschiene in das Festverglasungsprofil klicken.
Bei Wandmontage - Seite 7 beachten.

*Clip top track and fixed glass profile with the cage nut.
With wall assembly - Watch page 7*

02

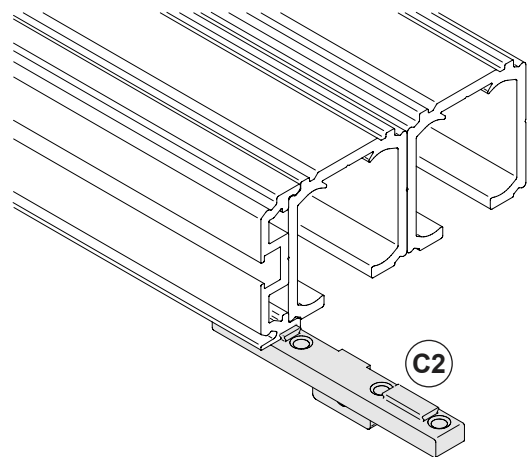
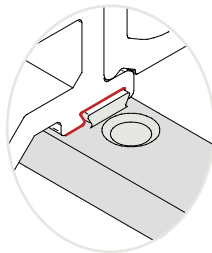
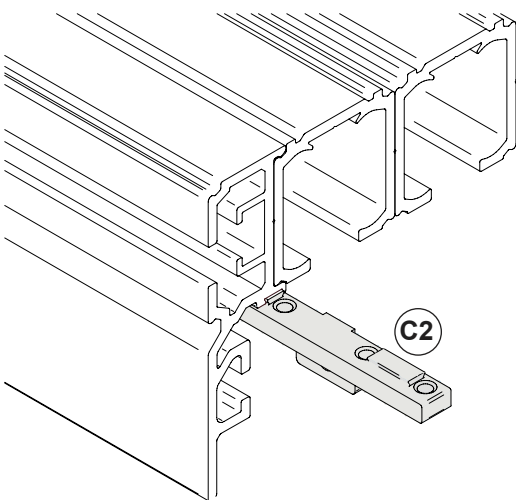

03

3a

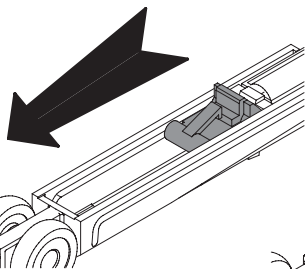

3b

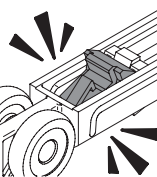

Den Haken von Position 2a zu
Position 2b drücken bis es klickt.
*Press the hook from position 2a to
2b since it clicks.*

04

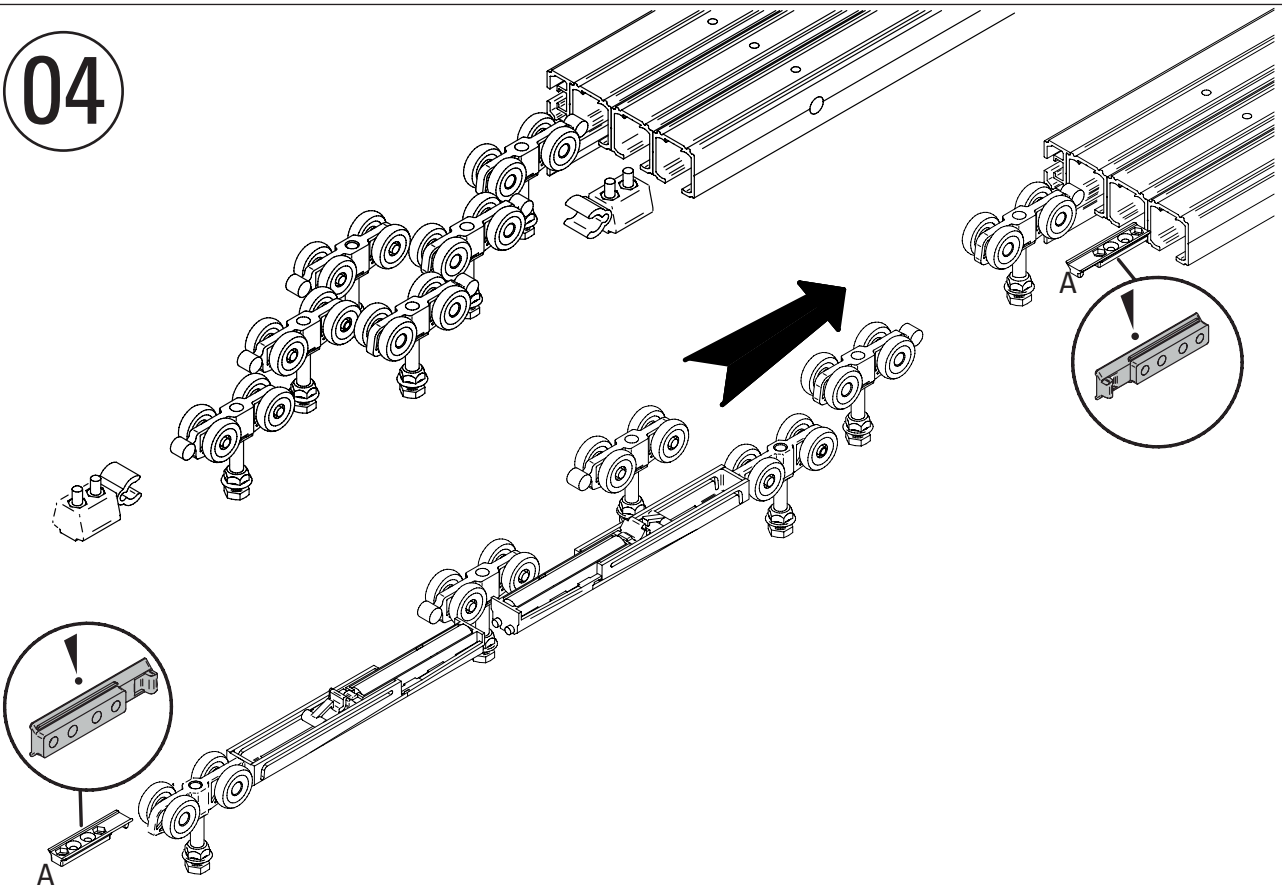

05

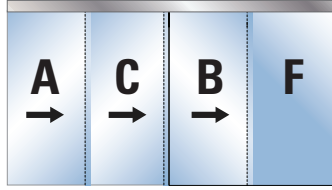

Öffnung rechts · *Right side opening*

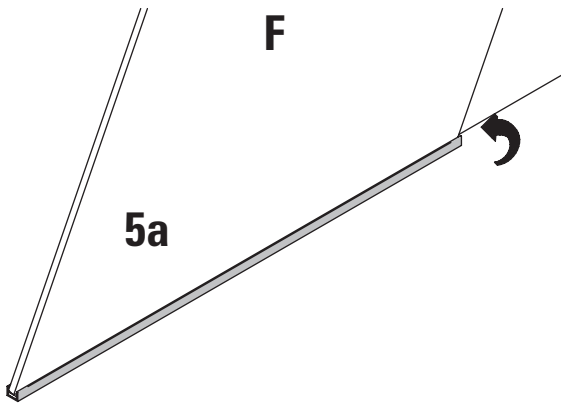

Montage Festverglasung
Assembly fixed glass

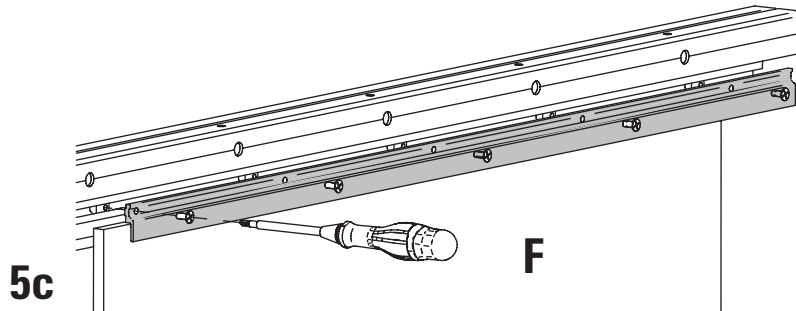
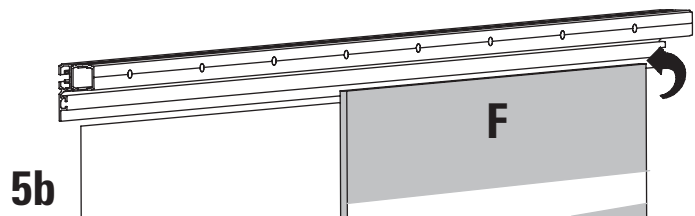

06

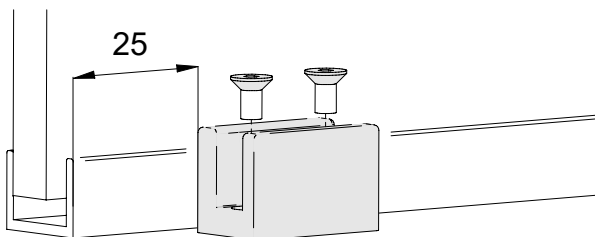

Installieren Sie die Bodenführung 25 mm
versetzt zu der Festverglasung
Install the lower guide 25 mm to fixed glass

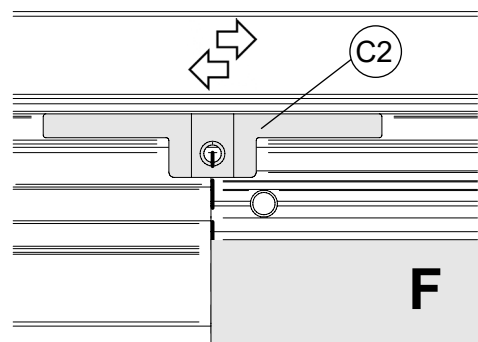

C2 einsetzen
Place C2

07

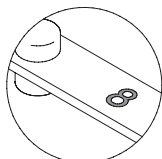

8 mm

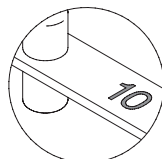

10 mm

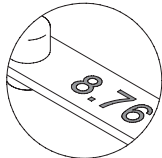

8,76 mm

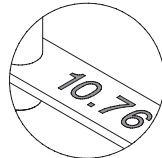

10,76 mm

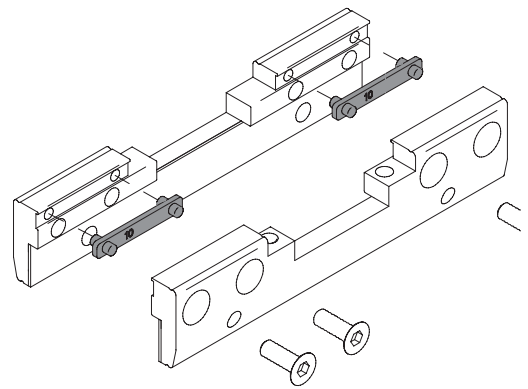

08

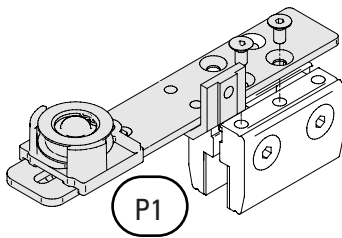

P1

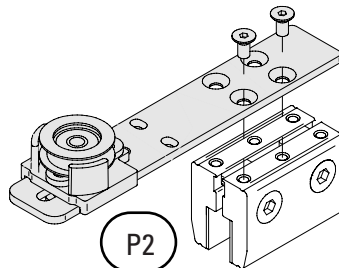

P2

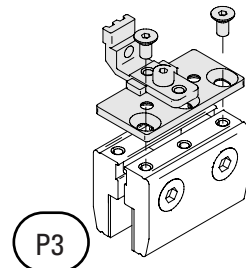

P3

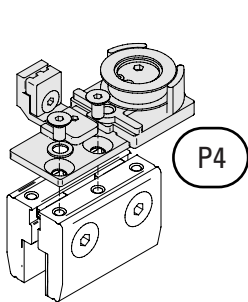

P4

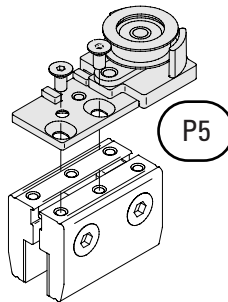

P5

09

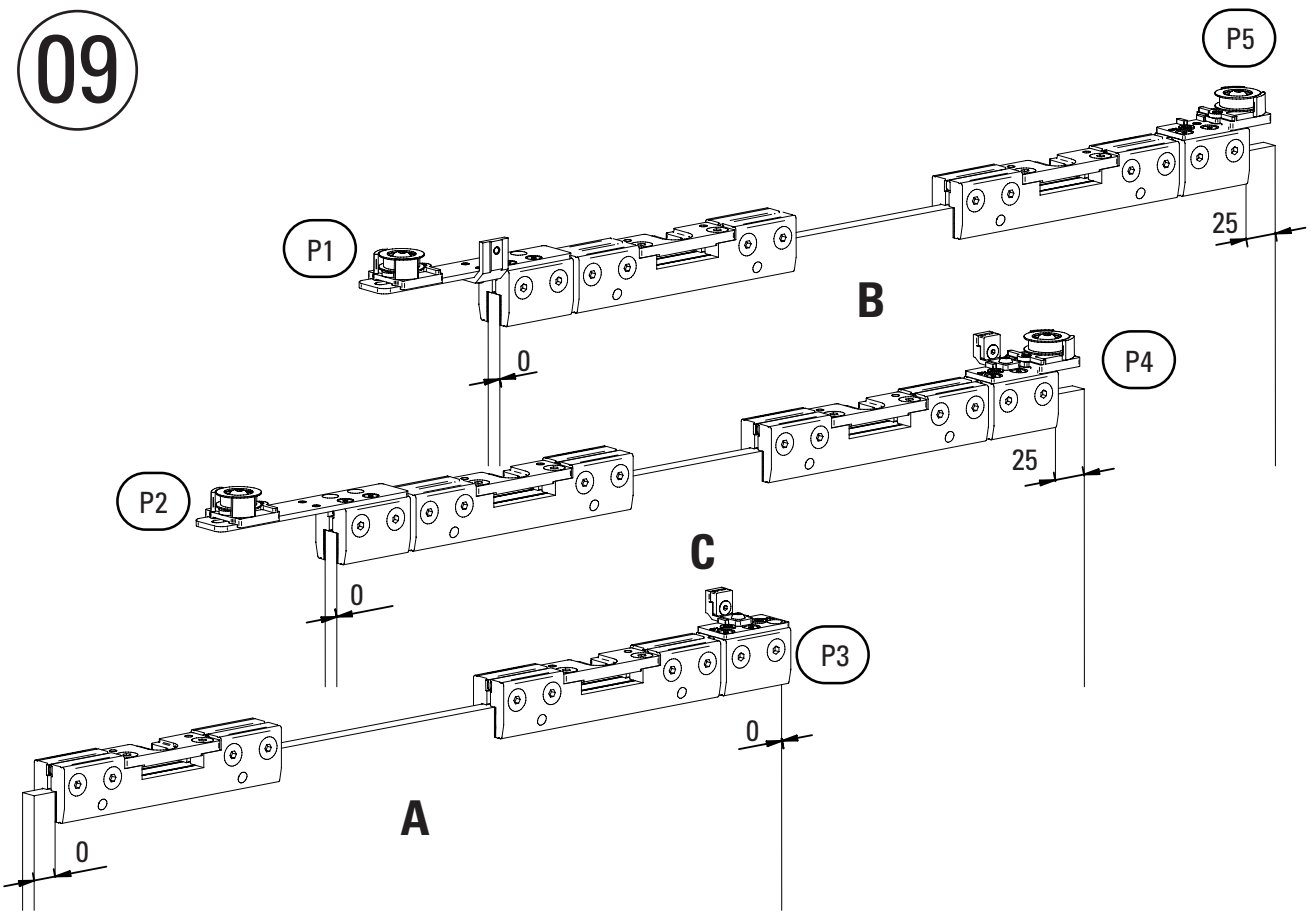

10

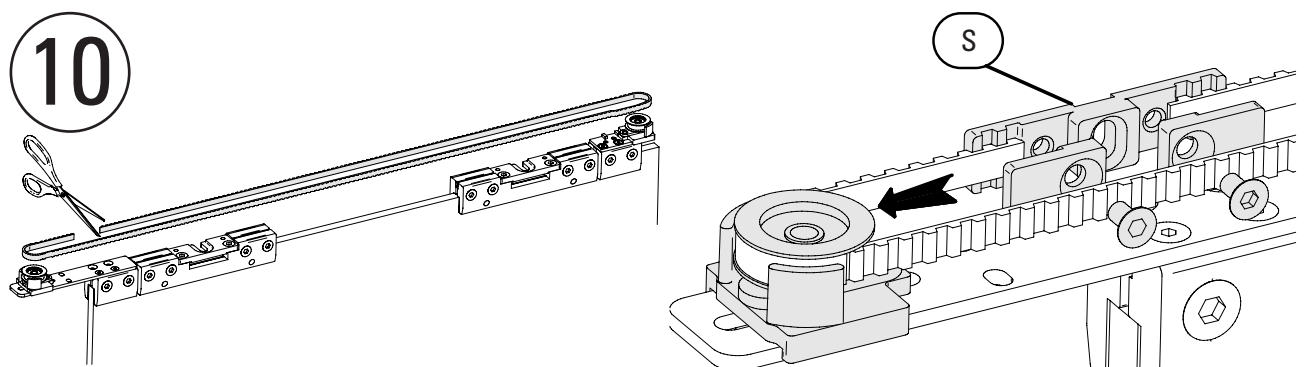

Den Zahnriemen schneiden und an S befestigen. Den Zahnriemen durch das drehen des Rads an P1 und P2 spannen

Panel B and C. Cut the toothed belt. Tighten it to S. Stretch by moving the wheel of the clamp P1 and P2

11

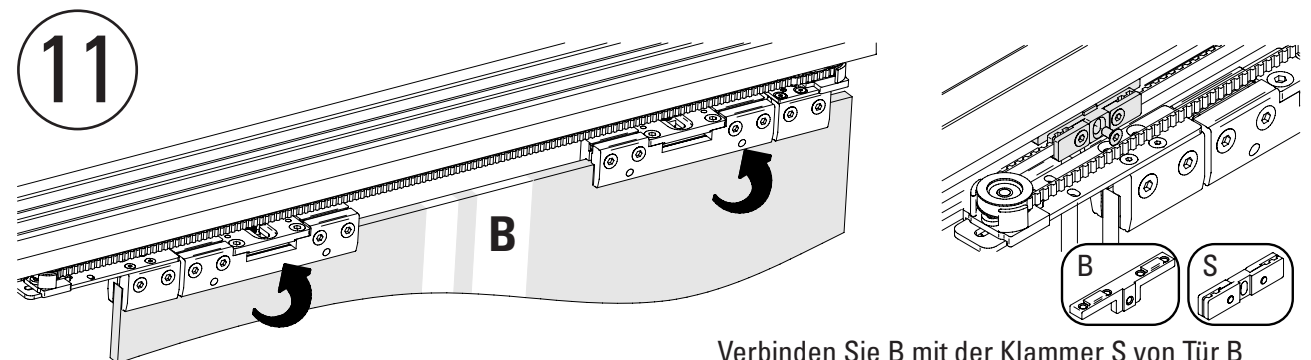

Verbinden Sie B mit der Klammer S von Tür B

Join B to the clip S of panel B

12

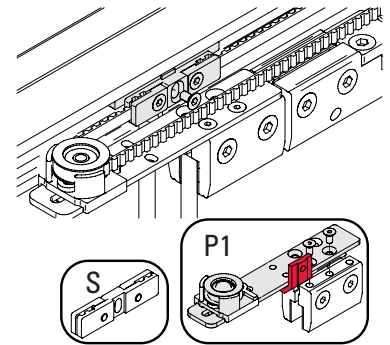
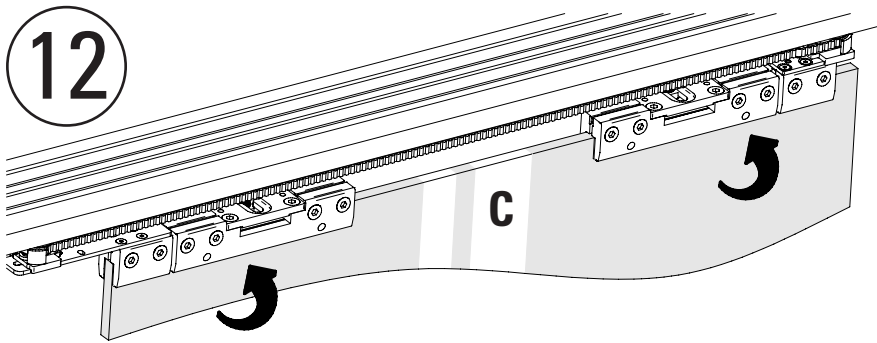

Verbinden Sie die Klammer S der Tür C mit der Klemme P1
 Join the clip S of panel C to the clamp P1

13

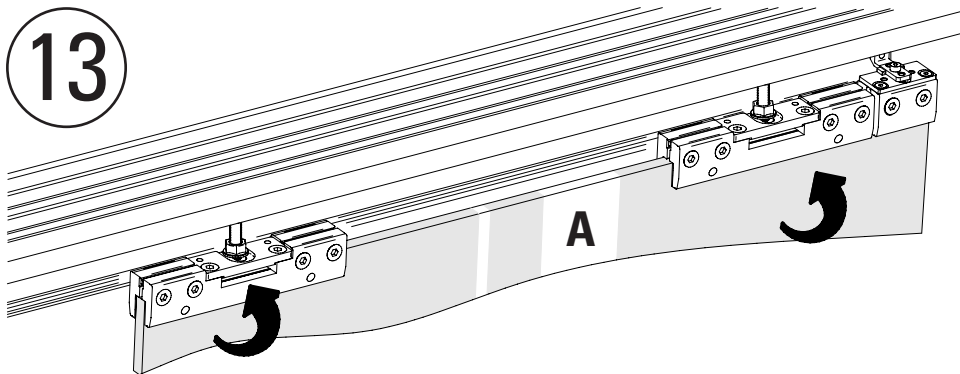

14

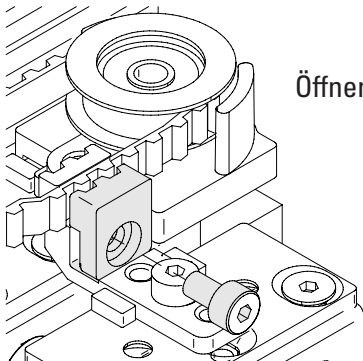
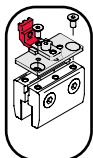
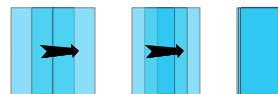

Öffnen Sie alle Türen. Verbinden Sie P3 mit dem mit dem Zahnriemen der Tür C.
 Open all the panels. Join P3 to the toothed belt of C panel.

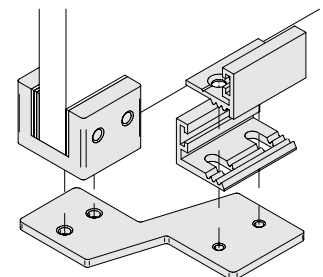

Bodenführung anbringen
 Install lower guide

15

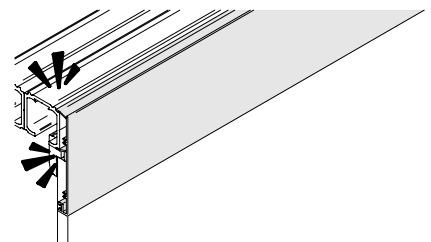
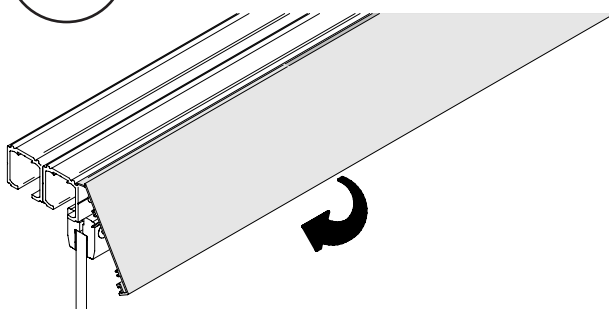

05

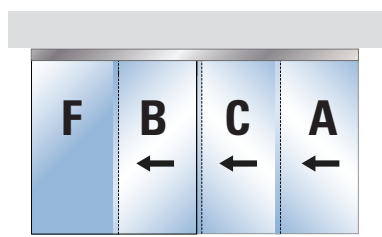

Öffnung links · *Left side opening*

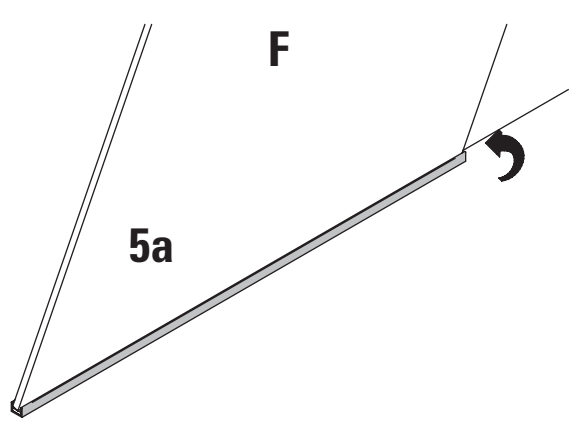

Montage Festverglasung
Assembly fixed glass

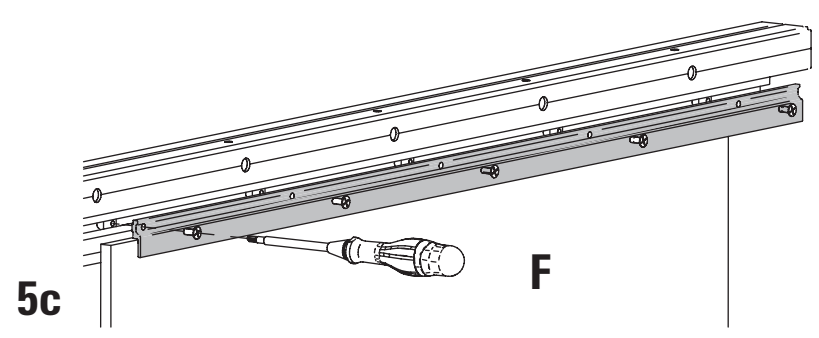
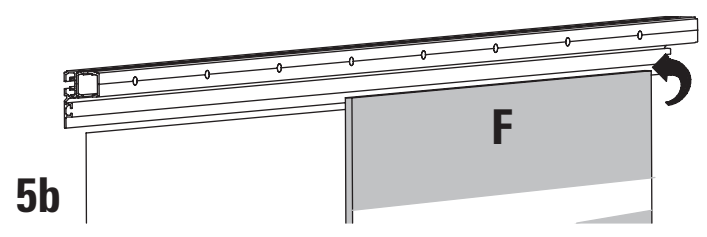

06

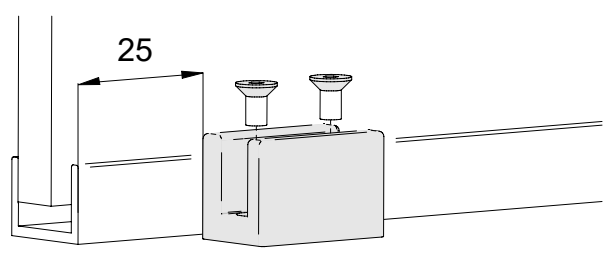

Installieren Sie die Bodenführung 25 mm
versetzt zu der Festverglasung
Install the lower guide 25 mm to fixed glass

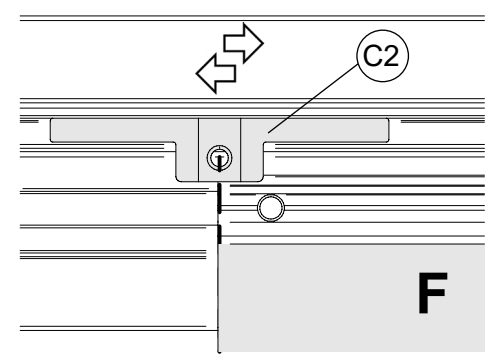

C2 einsetzen
Place C2

07

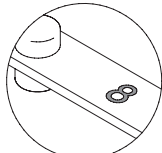

8 mm

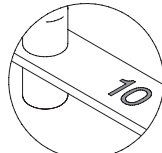

10 mm

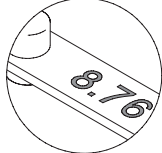

8,76 mm



10,76 mm

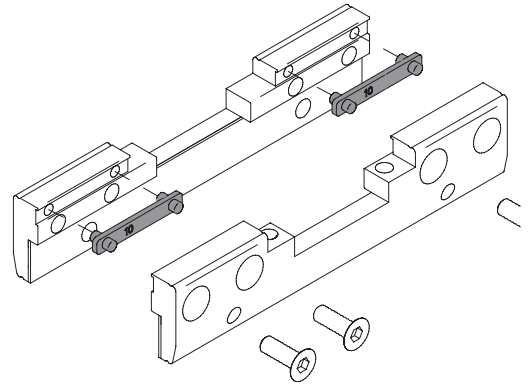

08

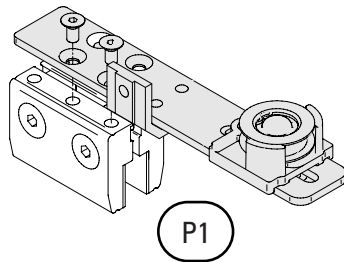

P1

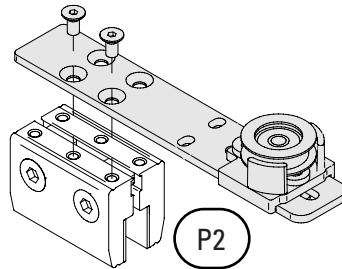

P2

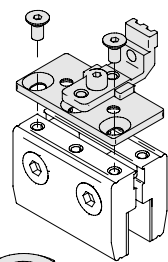

P3

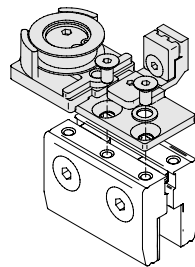

P4

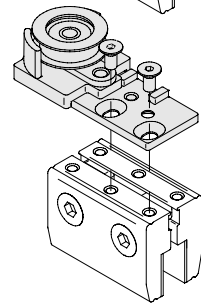

P5

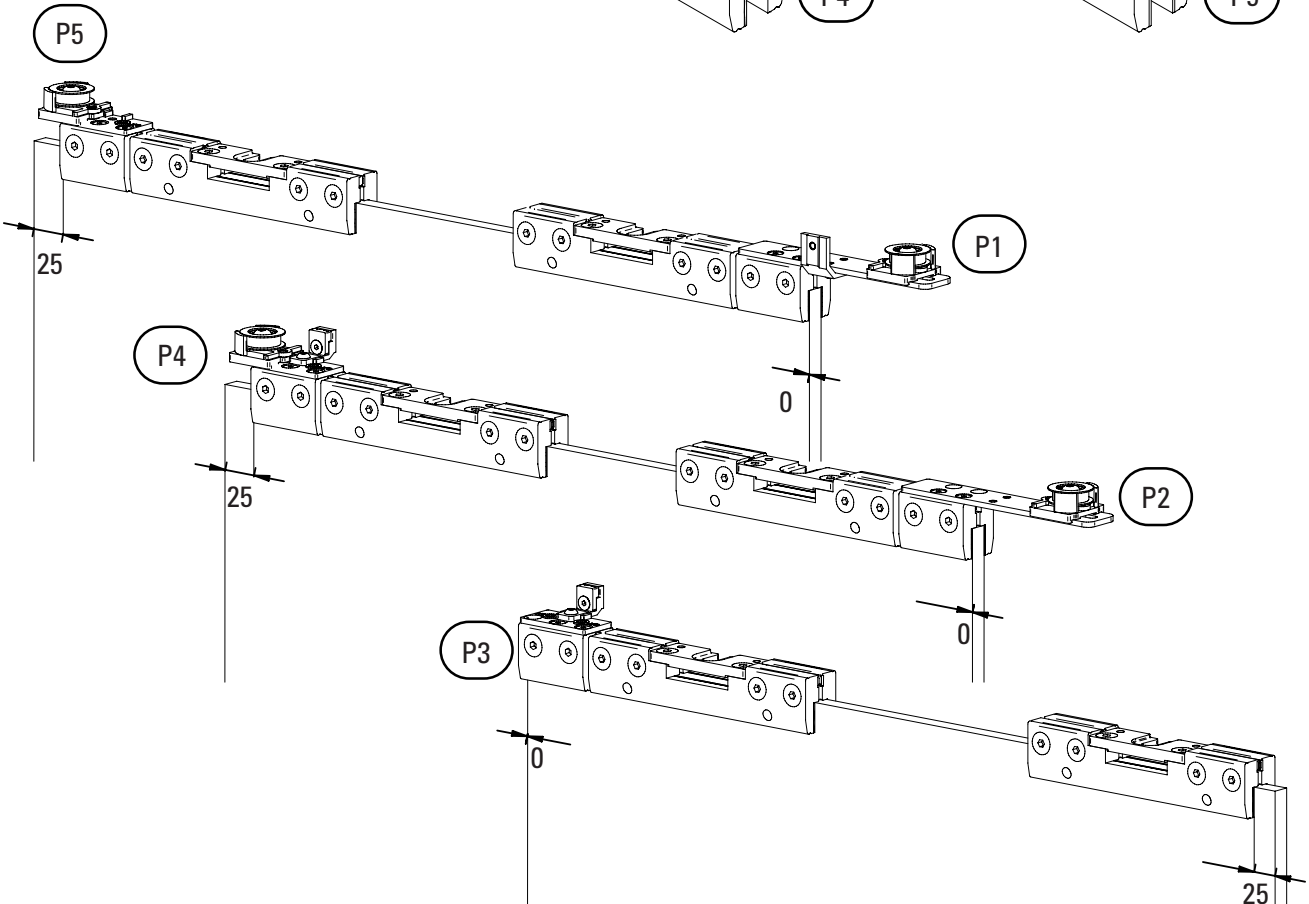

09

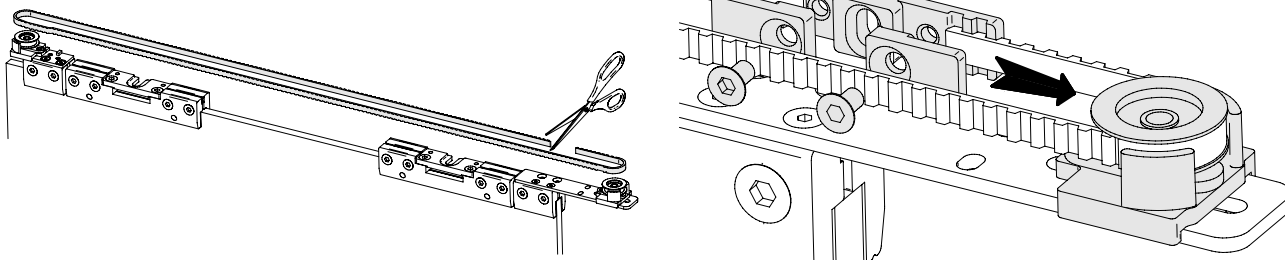

Den Zahnriemen schneiden und an S befestigen. Den Zahnriemen durch das drehen des Rads an P1 und P2 spannen

Panel B and C. Cut the toothed belt. Tighten it to S. Stretch by moving the wheel of the clamp P1 and P2

10

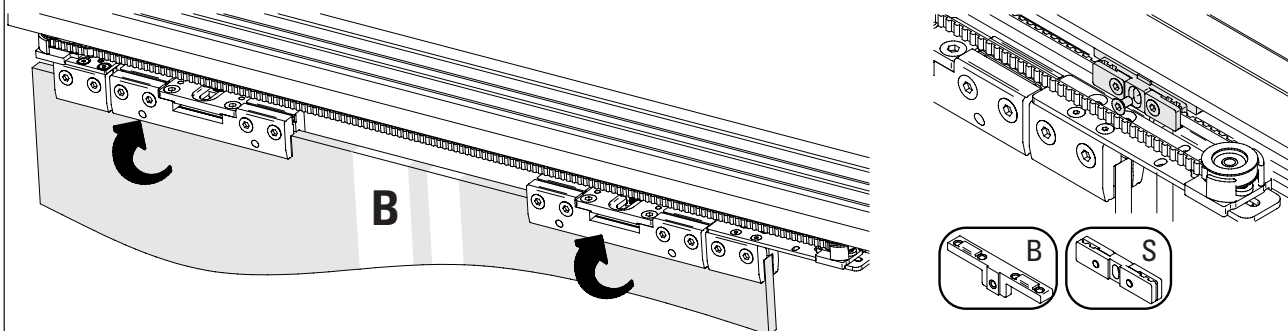

Verbinden Sie B mit der Klammer S von Tür B
Join B to the clip S of panel B

11

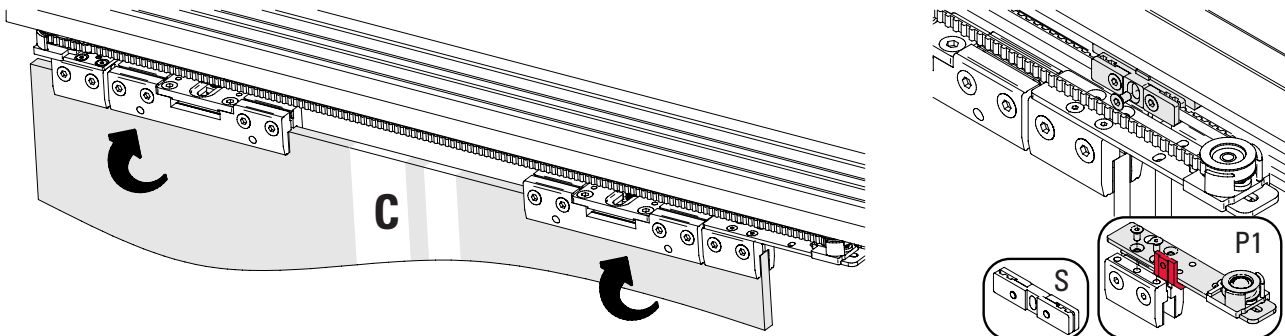

12

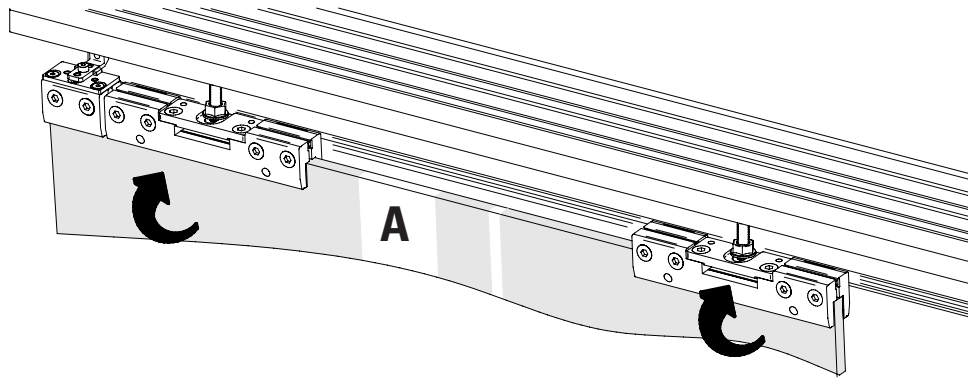

13

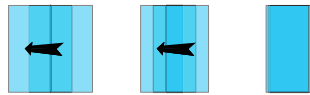
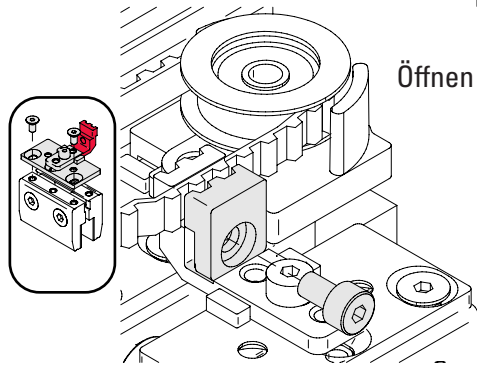

Öffnen Sie alle Türen. Verbinden Sie P3 mit dem mit dem Zahnriemen der Tür C.

Open all the panels. Join P3 to the toothed belt of C panel.

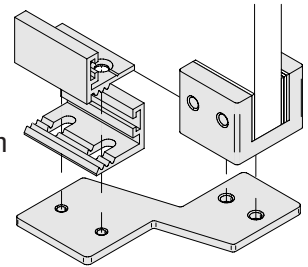

Bodenführung anbringen
Install lower guide

14

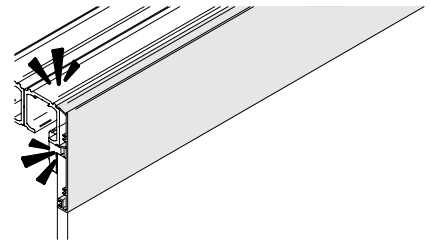
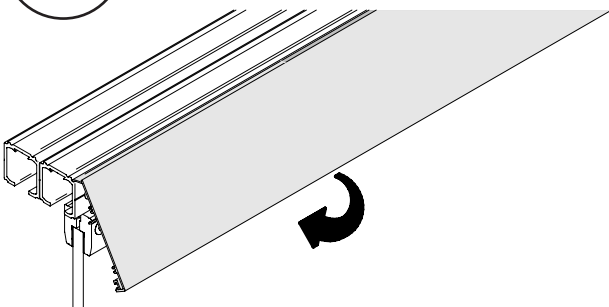

Bohle Worldwide

Germany

Bohle AG
42781 Haan
T +49 2129 5568-100
info@bohle.de

Austria | Hungary Slovenia

Bohle GmbH
1230 Wien
T +43 1 804 4853-0
info@bohle.at

Benelux

Bohle Benelux B.V.
3905 LX Veenendaal
T +31 318 553151
info@bohle.nl

China

Bohle Trading Co., Ltd
Tianhe District, Guangzhou
T +86-20-38105870
jiang.du@bohle.de

Croatia

Bohle d.o.o.
51000 Rijeka
T +385 051-329-566
info@bohle.hr

Estonia

Bohle Baltic
13619 Tallinn
T +372 6112-826
info@bohle.ee

France

Bohle AG · Departement Français
42781 Haan, Germany
T +49 2129 5568-222
france@bohle.de

Italy

Bohle Italia s.r.l.
20080 Vermezzo (MI)
T +39 02 94967790
info@bohle.it

Russia

Bohle Москва
108811 Москва
T +7 495 230-94-00
info@bohle.ru

Russia

Bohle Санкт Петербург
198020 Санкт Петербург
T +7 812 4452792
info@bohle.spb.ru

Spain | Portugal

Bohle Complementos del Vidrio S.A.U.
E - 08029 Barcelona
T +34 932 615 361
info@bohle.es

South Africa

Bohle Glass Equipment (Pty) Ltd.
2125 Gauteng
T +27 11 792-6430
info@bohle.co.za

Sweden

Bohle Scandinavia AB
14175 Kungens Kurva
T +46 8 449 57 50
info@bohle.se

United Kingdom

Bohle Ltd.
Dukinfield, Cheshire, SK16 4PP
T +44 161 3421100
info@bohle.ltd.uk

USA | Canada

Bohle America, Inc
Charlotte, NC 28273
T +1 704 247 8400
info@bohle-america.com

Bohle AG
Dieselstraße 10
42781 Haan

T +49 2129 5568-100

info@bohle.de

Für Anliegen rund um das Beschlagsortiment:

@ beschlag@bohle.de
☎ 02129 5568 951

Für die Unterstützung bei der Projektplanung:

@ technik-beschlag@bohle.de
☎ 02129 5568 953

For matters relating to the fittings range:

@ hardware@bohle.de
☎ +49 (0) 2129 5568 951

For support with project planning:

@ technical-hardware@bohle.de
☎ 02129 5568 953

