

Vitinni 8L Twin Drawer Digital Air Fryer

PLEASE READ AND KEEP THESE INSTRUCTIONS FOR FUTURE USE

SAP Code: JF07520257

For further assistance, other products and more, join us at:

Website: www.vitinni.co.uk

Instagram: [@vitinniuk](https://www.instagram.com/vitinniuk)

Facebook: www.facebook.com/vitinni

Thank you for choosing our Vitinni 8L Twin Drawer Digital Air Fryer. Please read this user manual carefully before use and keep it for future reference. The manufacturer and importer do not accept any liability if the information in these operation instructions is not complied with. If you need any assistance, please contact our customer service team on the details provided on the back page of this manual. Basic safety precautions should always be followed when using this appliance.

SAFETY INSTRUCTIONS

This appliance is for indoor use only.

This appliance is for domestic use only and should not be used for commercial purposes.

Check that the voltage on the rating plate corresponds with that of the local network before connecting the appliance to the mains power supply.

This appliance can be used by children aged from 8 years and above and persons with reduced physical, sensory or mental capabilities or lack of experience and knowledge providing they have been given supervision or instruction concerning use of the appliance in a safe way and understand the hazards involved. Cleaning and user maintenance shall not be undertaken by children unless they are older than 8 years and supervised.

This is not a toy - children should be supervised to ensure they do not play with the appliance. Keep the appliance and its cord out of reach of children less than 8 years.

If the appliance, power supply cord and plug are malfunctioning or they have been dropped or damaged switch off the appliance and discontinue use immediately.

This appliance contains no user serviceable parts. Repairs should only be undertaken by the manufacturer, its service agent or a similar qualified person. If the power supply cord is damaged, it must be replaced by the manufacturer, its service agent or a similar qualified person in order to avoid a hazard.

Keep the power supply cord away from sharp edges and parts of the appliance that may become hot during use. Do not allow the power supply cord to overhang the worktop.

Do not use this appliance with an extension lead or multiple socket adaptor. Do not use this appliance near an open flame or in moist or damp conditions. Keep the appliance away from other heat emitting appliances.

Allow sufficient space around the Air Fryer for ventilation and heat dissipation. Place on a flat, stable, heat resistant surface a minimum distance of 5 to 10 cm from walls and other items.

Do not leave the appliance unattended whilst connected to the mains power supply. Switch off the mains power supply and remove the plug by hand.

Always disconnect the appliance from the power supply before assembling, disassembling or performing cleaning or maintenance.

Do not immerse the Air Fryer, power supply cord or plug in water. Care should be taken to avoid spillage on the electrical components, power cord and plug. Do not operate the appliance with wet hands.

Do not use any accessories or attachments with the appliance that have not been supplied or recommended by the manufacturer.

This appliance is not intended to be operated by means of an external timer or separate remote control system.

Ensure that the air vents of the Air Fryer are not covered and there is sufficient space for the warm air exhaust to dissipate.

Extending the recommended cooking times, overfilling or placing food too close to the heating element could lead to food burning. When it is safe to do so clean any residual food and oil from the Air Fryer and accessories.

Ensure the grill is clean and dry before using the Air Fryer. Do not use liquids, plastic dishes, bowls or cling film inside the Air Fryer and do not fill the tray with oil or fat.

The Air Fryer has a built-in safety switch and will switch to Standby mode if the basket is removed. Nominal voltage is still present even when the Air Fryer is in Standby mode. To permanently switch off the hot air fryer, ensure it is turned off at the mains power supply.

Caution: Misuse of the appliance could cause injury – do not use the appliance for anything other than its intended use.

In order to avoid a hazard due to inadvertent resetting of the thermal cut-out, this appliance must not be supplied through an external switching device, such as a timer, or connected to a circuit that is regularly switched on and off by the utility.



Caution: Hot surface. To avoid injury do not touch the hot or heated surfaces of the product. The heated surfaces and heating element may contain residual heat and still be hot after use. Allow the product to cool fully before moving or handling. The outer surface and drawer cover may become hot when the appliance is operating.

The drawers and grills will become hot when the Air Fryer is in use. Only hold the drawers by their handles and allow the grills to cool before removing them from the drawers.

CLEANING & MAINTENANCE

This Air Fryer should be cleaned thoroughly after every use to remove any fat and grease. Failure to do so could cause a build up of flammable residues inside the Air Fryer which can cause serious injury or property damage.

Always put any excess oil or fat in the bin and not down the sink as this can cause blockages.

Unplug the Air Fryer from the mains power supply and allow to cool fully before performing any cleaning or maintenance.

Do not use strong detergent, sharp objects, brushes or metal objects to clean the product and accessories as this could cause damage to the non-stick finish.

Remove the Drawer and wipe the Main unit inside and out with a soft, damp cloth and a small amount of mild detergent. Do not immerse the main unit in water. Only the trivet is dishwasher safe.

The Drawer and Trivet can be cleaned with hot, soapy water and a non-abrasive sponge.

The trivet is dishwasher safe in the top rack only but we recommend manually cleaning with hot, soapy water to protect the non-stick coating.

STORAGE

Before storing, ensure that the Air Fryer is cool, clean and dry. Reassemble all of the parts and wrap the power cord loosely around the body of the Air Fryer.

Never wrap the cord tightly to avoid causing damage. Store in a cool, dry place away from direct sunlight.

TECHNICAL DATA

Voltage	Wattage	Frequency	Capacity	Temperature	Timer
220 – 240 V	2800 W	50 – 60 Hz	8L	60 – 200 (°C)	1-360min

WEEE INFORMATION

The symbol  on this product or its packaging means that this product should not be treated as household waste. It should be handed to an appropriate collection point for the recycling of electrical and electronic equipment. Contact your local council or household waste disposal service for further information. Do not dispose of electrical appliances as unsorted municipal waste, use separate collection facilities.

DESCRIPTION OF PARTS

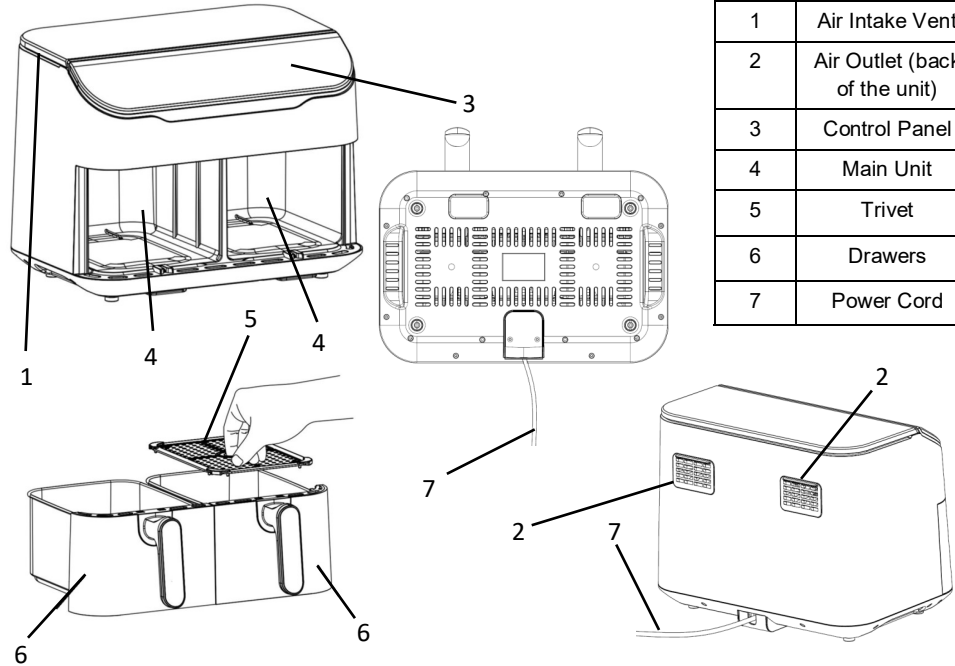

Part	Description
1	Air Intake Vent
2	Air Outlet (back of the unit)
3	Control Panel
4	Main Unit
5	Trivet
6	Drawers
7	Power Cord

NOTE: The food will need to be shaken/turned over during the cooking process to ensure even cooking. We recommend turning over the ingredients around halfway through each cooking cycle.

Please use the cooking guide provided. Final cooking times and temperatures may need adjusting for optimal results and user preference.







We recommend preheating the unit for 3 minutes to ensure optimal cooking results.

DISPLAY SCREEN

Below is the display screen of the 8L Air Fryer:



DISPLAY BUTTONS

Button	Function
	Selection buttons for Drawer 1 and Drawer 2
	LED Display
	Mode selection button
	Right , touch buttons to control the time setting. Use '+' to increase cooking time and '-' to decrease cooking time (up to 60 minutes)
	Left , touch button for temperature control. Use '+' to increase temperature and '-' to decrease temperature
	Start button , use to start or pause the cooking cycle
	Power button , touch to turn on/off

BEFORE FIRST USE

Before use, remove all packaging materials. Check all accessories are present and that the equipment is not damaged.

The Air Fryer should be cleaned according to the instructions in the Cleaning and Maintenance section.

The Air Fryer should be run through an operational cycle (200°C, 15 mins) before it is used for the first time.



When using the Air Fryer for the first time a slight odour may be emitted. This is normal and will soon subside.

Ensure that the product is on an even and stable surface that is heat-resistant.

Never pour oil or other liquids into the frying drawer. Do not cover the air inlet opening of the product as this will prevent the air flow.

Wipe the inside chambers and outside unit with a moist cloth.

INSTRUCTIONS FOR USE

1. Pull the drawer out of the main unit and ensure the trivet is even placed in the bottom. Re-insert the drawer into the air fryer.
2. Place the prepared ingredients into the drawer on top of the trivet.
NOTE: Do not overfill the drawers
3. Slide the drawer back into the main unit of the Air Fryer.
4. Plug the Air Fryer into a wall socket and ensure the air outlet is away from the wall.
5. Press the Power button  to turn the appliance on.
6. Choose the Drawer unit you wish to use by using the Numbered buttons to select Drawer 1 or 2. 
7. A) Using built-in cooking programme

Press button  to select the relevant preset cooking program to the required time and temperature for the ingredients.

The timer and the temperature of the built-in cooking programme can be further adjusted manually by pressing the “+” or “-“ button on both timer and temperature control section on the control panel.



B) Using manual cooking programme

Adjust the timer and the temperature by pressing the “+” or “-“ button located on both timer and temperature control sections on the control panel.



9. Press the Start button  to start the cooking cycle.
 10. We recommend turning over or shaking the food around halfway through the cooking time.
 11. At the end of the cooking cycle, the fan will continue operate briefly in order to cool down the internal compartment of the Air Fryer, the unit will then make a beeping sound to alert you that its finished.
 12. Remove the drawer with the handle and place on a heat-resistant surface.
- WARNING:** Do not touch the drawer itself or the trivet as they will be very hot.
13. Remove the ingredients from the trivet with a pair of non-metallic tongs.

Follow the **CLEANING AND MAINTENANCE** section for guidance as to how best to clean the air fryer.

C) Pause and resume the cooking programme during use

Pausing a Cooking Program:

Press the start button  to pause an ongoing cooking program. The timer will pause, displaying the remaining time of the ongoing program.



Resuming a Cooking Program:

To resume a paused program, press the start button  again. The timer will continue counting down until the remaining cooking cycle ends.

Note:

Pause and resume functions can also be activated by controlling the main power supply. All functions will immediately stop if the power supply is disconnected. The cooking program will automatically resume when the power supply is restored.

D) Turn off the Air Fryer

To power off the Air Fryer, press the power button.  The fan will continue operating briefly to facilitate the cooling of the internal compartment. If you wish to manually end the cooling process during this time, simply press the power button  again.

COOKING TIPS

Food that can be prepared in a oven can also be prepared in the Air Fryer.

You can also use the Air fryer to reheat food. To reheat ingredients, set the temperature to 150°C for up to 10 minutes.

Always ensure any excess oil that has collected in the drawer is put in a paper towel and placed in the bin and not poured down the sink as this can cause blockages.

You can utilize both trays simultaneously by initiating separate cooking programs for each tray.

COOKING GUIDE

Here are some guidelines you can follow to help get started:

Please note that the times and temperature will vary according to the size and shape of your food. Please use the information below as a guide to help with your cooking.

Vegetables

Ingredient (Vegetable)	Temperature (°C)	Time (Minutes)
Broccoli	200°C	11 Minutes
Carrots	200°C	15-16 Minutes
Courgette	200°C	7-10 Minutes
Mushrooms	200°C	8-10 Minutes
Potatoes	200°C	(Varies depending on size, cut, etc.) 18 - 40 Minutes
Sweet Potato	200°C	(Varies depending on size, cut, etc.) 20-40 Minutes
Parsnips	200°C	16-18 Minutes

Fish and Seafood

Ingredient	Temperature	Time
Prawns	200°C	3-5 Minutes
Cod Fillet	200°C	7- 9 Minutes
Salmon Fillet	200°C	12-14 Minutes
Fish Cakes	200°C	12-14 Minutes

Meat and Poultry

Ingredient	Temperature	Time
Chicken Breast	200°C	15-17 Minutes
Chicken Wings	200°C	25-30 Minutes
Beef Burger	190°C	10-12 Minutes
Beef Steak	200°C	7-12 Minutes
Bacon	200°C	9-10 Minutes
Sausages	200°C	8-12 Minutes
Pork Chops	180°C - 200°C	12-20 Minutes
Lamb Chops	180°C	10-12 Minutes
Lamb Steaks	180°C	12-15 Minutes

Frozen Foods:

Ingredient	Temperature	Time
Frozen Chips	190°C	20-25 Minutes
Hash Browns	200°C	15-18 Minutes
Onion Rings	200°C	25-28 Minutes
Chicken Nuggets	200°C	25-30 Minutes
Sausage Patties	180°C	15-18 Minutes
Frozen Meatballs	180°C	15-18 Minutes
Cod Fillet	200°C	12-15 Minutes
Fish Fingers	200°C	15-18 Minutes
Breaded Prawns	200°C	8-10 Minutes

NOTE: Steam may be emitted from the Air Fryer drawer during the cooking process, when it is opened during or shortly after cooking has finished. This is a normal part of the cooking process especially when cooking frozen food and food containing a lot of moisture.

TROUBLESHOOTING

Problem	Possible Cause	Solution
The Air Fryer does not work	The appliance is not plugged in.	Pug the mains plug into an wall socket and ensure it is switched on.
	The internal components are faulty.	Contact our Customer Service Team.
The ingredients are not fully cooked.	The amount of ingredients in the drawer.	Place smaller batches of ingredients in the drawer to ensure even heat distribution.
	The cooking temperature is too low.	Increase the cooking temperature using the temperature control knob .
	The cooking time is too short.	Increase the cooking time using the time control knob.
The ingredients are cooked unevenly.	Some foods need to be shaken or turned halfway through the allocated cooking time.	Ingredients that lie on top of or across each other (e.g. chips) need to be shaken halfway through the cooking cycle to ensure they cook evenly
White smoke comes out of the appliance	The ingredients in the drawer are greasy.	When greasy foods are cooked, the oil can leak through into the drawer. The oil can produce white smoke as it heats up. This does not affect the appliance or the end result.
	The drawer still contains grease or residue from previous use.	White smoke is caused by grease heating up in the drawer Ensure the drawer is cleaned properly before next use.
Fresh chips are fried unevenly.	The crispiness of the fries depends on the amount of oil and water in the fries.	Add a small amount of oil for a crispier result.

Guarantee

Our products are guaranteed for a period of 2 years from the date of purchase. Products that develop a fault within this period are covered by our warranty and we will replace defective parts, or where not available the whole product. The warranty does not apply to any defect in the goods arising from fair wear and tear, wilful damage, accident, negligence by you or any third party, use otherwise than as recommended by us, failure to follow our instructions, any alteration or repair carried out without our approval or has been the subject of commercial use. Your statutory rights remain unaffected, in particular any rights you have under the Consumer Rights Act 2015.

If you have a problem with your product within this warranty period please contact our customer services team.

In the event of changes to the specification of a product and we are not able to replace parts, we will replace the whole product within the 2 year guarantee period

For products that fall outside of the 2 year guarantee, we will endeavor to provide spare parts to purchase for as many of the replaceable parts as possible, but cannot foresee specification changes or upgrades to products or parts outside of the initial 2 year period.

Customer Services:

If you would like further advice or information on your product, ensure you have the SAP code ready and please get in touch with us at Vitinni on the contact options below:

SAP Code: JF07520257

Phone: 0330 002 1202 (Mon – Fri 9am to 5pm)

Email: support@vitinni.co.uk

UK Address: Vitinni, Vale Mill (Rochdale) Ltd, Robinson Street, Rochdale,
OL16 1TA, UK

EU Address: Vitinni, PL Innovations, Hauptstraße 103, 53619, Rheinbreitbach,
Germany