

**DRAPER**

**EN**

Original Instructions  
Version 3 - February 2025

# EXTENDING MITRE SAW **STAND**

**90248**



# 1. Preface

These are the original product instructions. This document is part of the product; retain it for the life of the product, passing it on to subsequent holders. Read this manual in full before attempting to assemble, operate or maintain this product.

This Draper Tools manual describes the purpose of the product and contains all the necessary information to ensure its correct and safe use. Following all the instructions and guidance in this manual will ensure the safety of both the product and the operator and increase the lifespan of the product.

All photographs and drawings within this manual are supplied by Draper Tools to help illustrate correct operation of the product.

Every effort has been made to ensure the information contained in this manual is accurate. However, Draper Tools reserves the right to amend this document without prior warning. Always use the latest version of the product manual.

## 1.1 Product Reference

**User Manual for:** Extending Mitre Saw Stand

**Stock No:** 90248

**Part No:** MSS165D

## 1.2 Revisions

**Version 1:** April 2019  
First release

**Version 2:** October 2024

**Version 3:** February 2025

As our manuals are continually updated, always ensure that the latest version is used.

Please visit [drapertools.com/manuals](http://drapertools.com/manuals) for the latest version of this manual and the associated parts list, if applicable.

## 1.3 Understanding the Safety Content of This Manual



**WARNING!** – Situations or actions that may result in personal injury or death.



**CAUTION!** – Situations or actions that may result in damage to the product or surroundings.

**Important:** – Information or instructions of particular importance.

## 1.4 Copyright © Notice

Copyright © Draper Tools Limited.

Permission is granted to reproduce this manual for personal and educational use **ONLY**. Commercial copying, redistribution, hiring or lending is strictly prohibited.

No part of this manual may be stored in a retrieval system or transmitted in any other form or means without written permission from Draper Tools Limited.

In all cases, this copyright notice must remain intact.

---

1. Preface	2
1.1 Product Reference	2
1.2 Revisions	2
1.3 Understanding the Safety Content of This Manual	2
1.4 Copyright © Notice	2
2. Contents	3
3. Product Introduction	4
3.1 Intended Use	4
3.2 Specification	4
4. Health and Safety Information	5
4.1 General Health and Safety Precautions	5
4.2 Residual Risk	5
5. Identification and Unpacking	6-7
5.1 Product Overview	6
5.2 What's in the Box?	7
5.3 Packaging	7
6. Assembling the Mitre Saw Stand	8-10
6.1 Unfold the Work Legs	8
6.2 Assemble Support Rollers	9
6.3 Mounting a Mitre Saw	9-10
7. Operating Instructions	11
7.1 Roller Bars/Extension Bar Adjustment	11
7.2 Storing the Stand	11
8. Maintenance and Disposal	12
9. Warranty	13
10. Explanation of Symbols	14

## 3.1 Intended Use

This lightweight portable stand is designed to offer strong workpiece support and is compatible with most makes of mitre saws.

Any other application beyond the conditions established for use will be considered misuse. Draper Tools accepts no responsibility for improper use of this product.

Read this manual in full before attempting to assemble, operate or maintain the product, and retain it for later use.

## 3.2 Specification

Stock No.	90248
Part No.	MSS165D
Extending Beam Length:	1000 – 1650mm
<b>Max. Height:</b>	
To beam:	740mm
To extending rollers:	810 – 910mm
Max. Width:	585mm
Max. Load Capacity:	150kg
Net Weight:	12.5kg

**Important:** Read all the Health and Safety instructions before attempting to operate, maintain or repair this product. Failure to follow these instructions may result in injury or damage to the user, the product or the workpiece.

## 4.1 General Health and Safety Precautions

- **When using this stand in conjunction with a mitre saw, the following steps should be taken to ensure the user remains safe:**
  - Before using, read and fully understand the instruction documentation supplied with the mitre saw. Pay particular attention to the relevant Health and Safety information. If you have any doubts or concerns regarding the ability to use the tool safely, **DO NOT proceed!**
  - Ensure you know how to safely start and stop the mitre saw, especially in an emergency.
  - Always keep the machine guards in place and ensure that they are in good working order, properly adjusted and aligned.
  - **ALWAYS** keep your hands away from the cutting area.
  - Common sense and respect for the tool will help reduce the risk of injury.
- **DO NOT overload the mitre saw stand.** The maximum safe weight limit is 150kg.
- Ensure all locking pins are in the set-up position holes before using the mitre saw and stand.
- **ALWAYS firmly attach the mitre saw to the stand. NEVER** attempt to use the mitre saw until it is firmly fastened to the stand.
- **Check the stability of the stand before use.** When a large piece of timber is cut from one end, the remaining piece may be heavy enough to tip over the stand. **ALWAYS** ensure the workpiece is well supported.
- **Keep the work area tidy and clean.**
- **Find a suitable location.**
  - The location should provide good natural or artificial light.
  - Avoid damp and dusty locations as they will have a negative effect on the stand performance. **DO NOT** expose to rain.
  - **DO NOT** operate the tool on the stand near flammable materials.

- **Keep bystanders away.** Children, onlookers and passers-by must be restricted from entering the work area for their own protection.
- **Wear appropriate personal protective equipment (PPE) as specified by the mitre saw manufacturer.**
- **DO NOT overreach.** Extending your body too far can result in a loss of balance and you falling.
- **DO NOT** modify the stand and **ONLY** use for its intended purpose.

## 4.2 Residual Risk

The safety instructions in this manual cannot account for all possible conditions and situations that may occur. Exercise common sense and caution when using this product and protect against any additional conceivable risks.

## 5.1 Product Overview

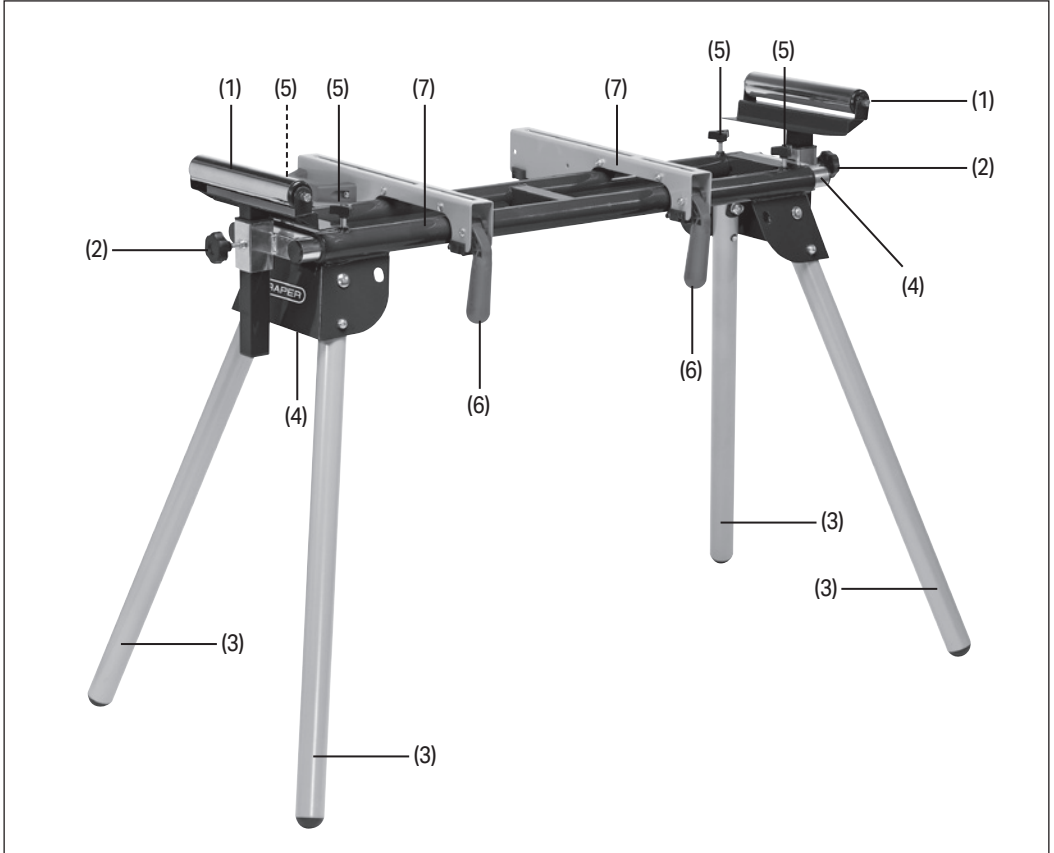

- |                                  |   |
|----------------------------------|---|
| (1) Support rollers              | (5) Extending beam locking knobs              |
| (2) Support roller locking knobs | (6) Mitre saw mounting bracket locking levers |
| (3) Legs                         | (7) Mitre saw mounting brackets               |
| (4) Extending beams              |   |

Please visit [drapertools.com](http://drapertools.com) for our full range of accessories and consumables.

## 5.2 What's in the Box?

Carefully remove the product from the packaging and examine it for any signs of damage that may have occurred during shipment.

Before assembling the product, lay the contents out and check them against the parts shown below. If any part is

damaged or missing, do not attempt to use the product. Please contact the Draper Helpline; contact details can be found at the back of this manual.

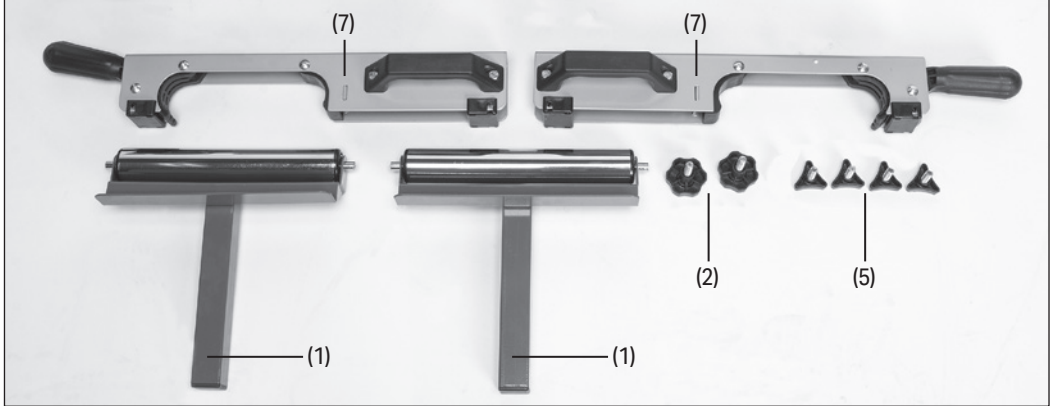

- (1) 2 X Support rollers
- (2) 2 X Support roller locking knobs
- (5) 4 X Extending beam locking knobs
- (7) 2 X Mitre saw mounting brackets
- (8) 4 X Mitre saw mounting bolts
- (9) 4 X Mitre saw mounting nuts
- (10) 4 X Mitre saw mounting washers
- (11) 4 X Mitre saw mounting locking washers

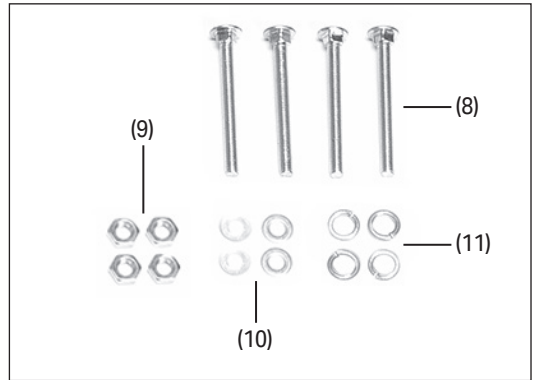

## 5.3 Packaging

Keep the product packaging for the duration of the warranty period in case the product needs to be returned for repair.



**WARNING! Keep packaging materials out of reach of children. Dispose of packaging correctly and responsibly and in accordance with local regulations.**

## 6. Assembling the Mitre Saw Stand

**Important:** Before preparing or adjusting this product, read and understand all the safety instructions listed in this manual.

### 6.1 Unfold the Work Legs (Fig.1 – Fig.4)

1. Place the stand on a flat surface with the folded legs (3) facing up.
2. Press in the leg locking pin (3.1).
3. Rotate the leg until upright and the button clicks and locks into the adjacent hole in the stand frame.
4. Repeat for each leg.

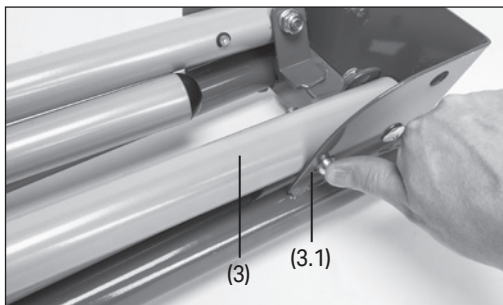

Fig. 1

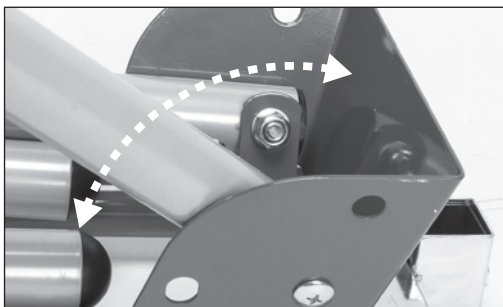

Fig. 2

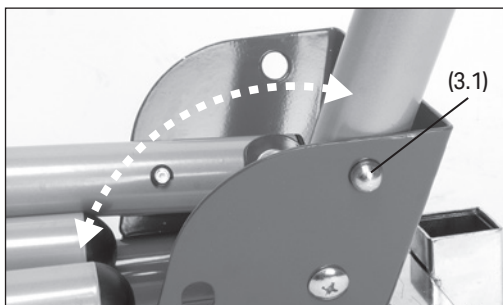

Fig. 3



Fig. 4

# 6. Assembling the Mitre Saw Stand

## 6.2 Assemble Support Rollers (Fig.5)

- Place the roller arms (1) into the roller bar supports (1.1).
- Slide up and down to the desired location and secure with the locking knobs (2).

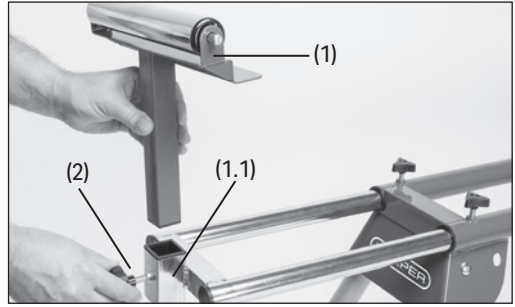

Fig. 5

## 6.3 Mounting a Mitre Saw (Fig.6 – Fig.12)



### WARNING! Risk of personal injury.

- Isolate the power supply from the tool before attaching to the mitre saw stand.
- **ALWAYS** ensure the mitre saw is fully supported and the stand is securely placed on a level work surface.
- **DO NOT** mount a table saw on this stand. Aggressive feeding of sheet material into a table saw could cause the stand to tip over.

**Note: This mitre saw stand is for use with mitre saws with four mounting holes in a rectangular pattern (Refer to current Fig.10).**

1. Before fitting the mounting brackets (7) to a mitre saw, check how easily the mounting brackets can be seated on the mitre saw frame.
2. The brackets may need to be adjusted so that they hook onto the frame without excessive play or tightness, and that the locking levers (6) can be easily applied.
3. To adjust the brackets, locate the adjustment screw (7.2) on the underside of the bracket. Loosen the locking nut (7.3) with a pair of pliers or spanner. Then turn the adjustment screw using a cross-slot screwdriver.
4. Turn the screw clockwise to tighten the clamping tension and anti-clockwise to loosen the clamping tension (6).
5. Once the brackets are sitting correctly on the frame, retighten the locking nuts. Check that the locking levers (6) can be activated to secure the bracket safely.
6. Remove the mounting brackets from the frame and attach them onto the underside of the mitre saw using the fittings supplied.

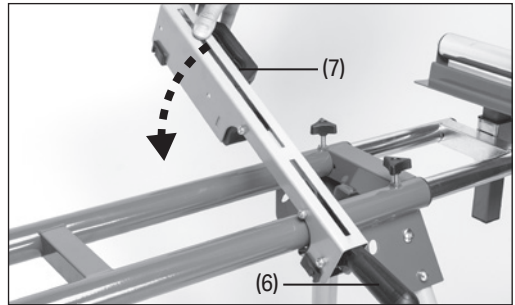

Fig. 6

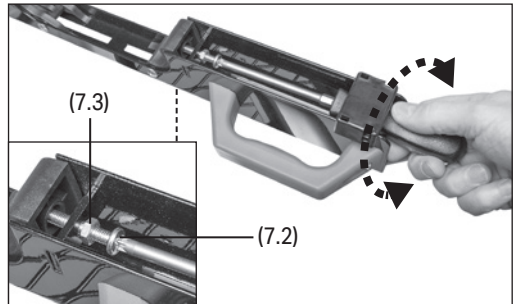

Fig. 7



Fig. 8

## 6. Assembling the Mitre Saw Stand

### Notes:

- Ensure that you fit the brackets to the saw the correct way round, so that the carry handles (7.1) are facing outwards (Refer to Fig.9).
  - The mitre saw can be heavy, so it is recommended that another person assists with this part of assembling.
7. Thread the mitre saw mounting bolt (8) through the slot in the underside of the mounting bracket (7) and up through into the mounting hole of the mitre saw.
  8. Slide a mitre saw mounting washer (10) over the bolt, followed by a locking washer (11) and then a mitre saw mounting nut (9).
  9. Hand tighten to secure.
  10. Repeat the above steps to attach and secure the other end of the bracket.
  11. When the mitre saw is sitting squarely on the two brackets, tighten up all four bolts.
  12. The mitre saw can now be lifted by the carry handles (7.1) and placed onto the stand frame.
    - Secure in place by activating the locking levers (6).

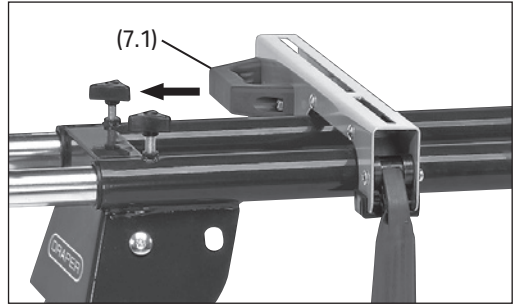

Fig. 9

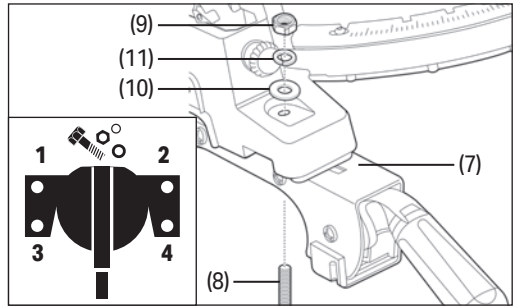

Fig. 10

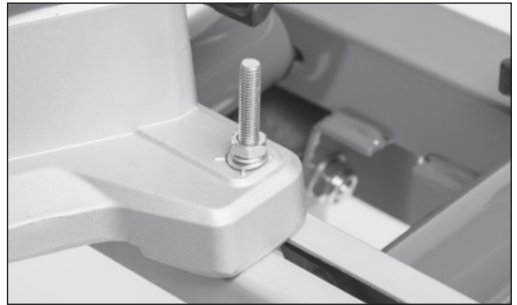

Fig. 11

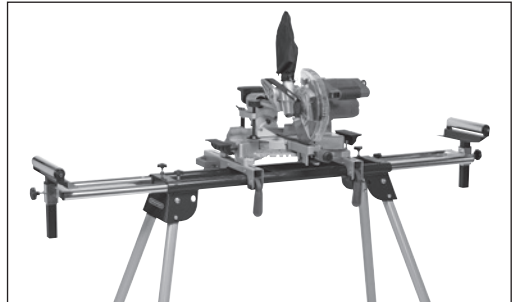

Fig. 12

**Important:** Before operating this product, read and understand all the safety instructions listed in this manual. Ensure that the product is fully assembled and correctly prepared for use.

## 7.1 Roller Bars/Extension Bar Adjustment

(Fig.13 – Fig.14)



### WARNING!

- DO NOT use the stand as scaffolding or as a ladder.
- Ensure all fastenings are securely tightened before using the stand.
- Maximum load capacity for this stand is 150kg.
- Mitre saws used on the stand must not exceed a combined overall height of 152.4cm (60") from the floor.
- **The left and right extending beams (4) move in and out to support the workpiece;**
  - Loosen the locking knobs (5), slide the extension bar in or out to the required position.
  - Re-tighten the locking knobs.
- **The support rollers (1) are used as directional rollers or with the extension bars as stationary stop guides:**
  - Loosen the locking knobs (2), slide the roller bars up and down to the required position.
  - Re-tighten the locking knobs.

## 7.2 Storing the Stand (Fig.15 – Fig.16)

- Fold up the stand for storage:
  - Press in the leg locking pin (3.1).
  - Rotate the leg until folded into the frame and the button locks into the adjacent hole in the stand frame.
  - Repeat for each leg.

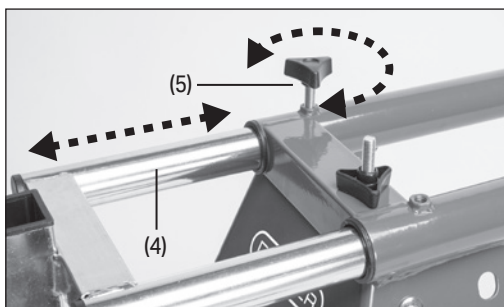

Fig. 13

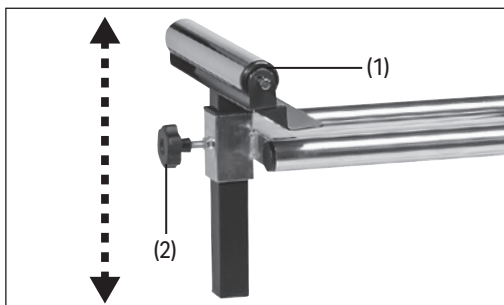

Fig. 14

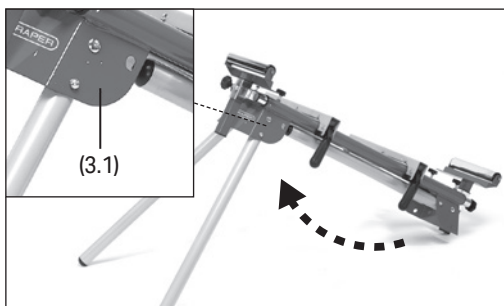

Fig. 15

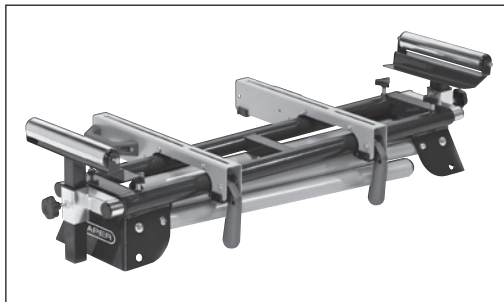

Fig. 16

**Important:** Unplug from the power supply and remove the mitre saw from the stand before carrying out any maintenance or cleaning.

- For best performance clean and maintain the stand correctly and on a regularly basis.
- Keep the stand clean and dry and free from oil and grease. Wipe over with a clean cloth.
- **DO NOT use abrasives, solvents or any other aggressive chemical to clean this stand.**
- Store in a dry location when not in use.
- At the end of its working life, dispose of the product responsibly and in line with local regulations. Recycle where possible. **DO NOT** dispose of this product with domestic waste; most local authorities provide appropriate recycling facilities.

Draper Tools products are carefully tested and inspected before shipment and are guaranteed to be free from defective materials and workmanship.

Should the tool develop a fault, return the complete tool to your nearest distributor or contact Draper Tools directly. Contact information can be found at the back of this manual.

Proof of purchase must be provided.

If, upon inspection, it is found that the fault occurring is due to defective materials or workmanship, repairs will be carried out free of charge. This warranty period covers 12 months for labour and 24 months for parts from the date of purchase.

This warranty does not apply to any consumable parts, batteries or normal wear and tear, nor does it cover any damage caused by misuse, careless or unsafe handling, alterations, accidents, or repairs attempted or made by any personnel other than the authorised Draper Tools repair agent.

In all cases, to make a claim for faulty workmanship or materials within the standard warranty period, please contact or return the product to the place of purchase. Proof of purchase may be required.

If the place of purchase is no longer trading or if you experience any difficulties with your warranty, please contact Customer Services with the product details and your proof of purchase. Contact details can be found at the back of this manual.

If the tool is not covered by the terms of this warranty, repairs and carriage charges will be quoted and charged accordingly.

This warranty supersedes any other guarantees expressed or implied and variations of its terms are not authorised.

Your Draper Tools guarantee is not effective until you can produce, upon request, a dated receipt or invoice to verify your purchase within the guarantee period.

Please note that this warranty is an additional benefit and does not affect your statutory rights.

### **Draper Tools Limited**



Read the instruction manual



Wear face mask and safety glasses



Wear ear defenders



Wear protective gloves



Keep out of the reach of children



**Warning!**



## Contact Details

### **Draper Tools**

Draper Tools Limited  
Hursley Road  
Chandler's Ford  
Eastleigh  
Hampshire  
SO53 1YF  
UK

**Website:** [drapertools.com](http://drapertools.com)

**Email:** [sales@drapertools.com](mailto:sales@drapertools.com)

**Product Helpline:** +44 (0) 23 8049 4344

**Telephone Sales Desk:** +44 (0) 23 8049 4333

**General Enquiries:** +44 (0) 23 8026 6355

### **Delta International**

Delta International BV  
Oude Graaf 8  
6002 NL  
Weert  
Netherlands

Please contact the Draper Tools Product Helpline for repair and servicing enquiries.