

Product size:

Coffee Table: L78*W78*H27cm

Corner Sofa: W80*D80*H67cm

Middle Sofa: W65*D80*H67cm

Left Hand Bench: W160*D80*H67cm

Right Hand Bench: W160*D80*H67cm

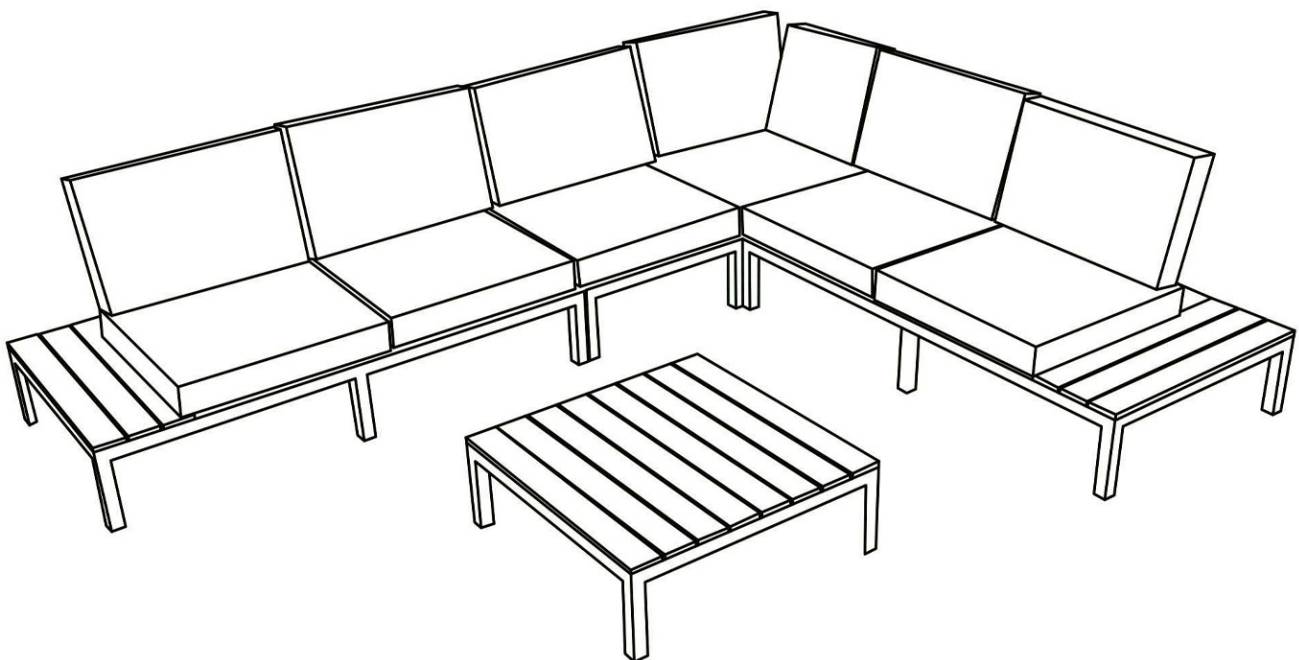

**Furniture should be covered/stored whilst not in use to prolong its longevity.
(It should also be covered in adverse weather.)**

The intended use of this product is for domestic use only.

Important, please retain for future reference.

Read carefully.

Aspen Left and Right Hand Bench, Middle Sofa, Corner Sofa and Coffee Table

Assembly Instructions

Before you start



Warnings

IMPORTANT, RETAIN FOR FUTURE REFERENCE READ CAREFULLY

See enclosed instructions for assembly, safety and care information.

Failure to follow the warnings could result in serious injury.

Handle heavy parts with care.

Ensure that this product is fully assembled as illustrated before use.

This product should only be used on firm, level ground.

Keep small parts out of reach of children.

Do not stand or climb onto this product.

This product is intended for **domestic use** only.

Ensure the product is always placed on level ground.

Furniture can be dangerous if incorrectly used. No liability will be accepted for damage or injury caused by incorrect use of this product.

✓ Dos

When you are ready to start, make sure that you have the right tools, plenty of space and a clean, dry area for assembly.

Unwrap all packaging materials and place the components on a suitable surface to prevent scratching your product.

Check all contents are present prior to assembly as per the parts list provided. In the event of problems or missing parts, please contact the seller.

Check all screws and bolts are tightened and inspect regularly.

Cover furniture when not in use to add additional protection to your product.

Store all cushions indoors after use as they are not waterproof.

During severe weather conditions, including high winds, rain, hail, thunderstorms, extreme heat and cold temperatures, the product should be stored inside in a cool, dry place.

To best preserve this product, please use a protective cover when your furniture is not in use. We would also recommend using a gazebo or parasol over your furniture during the summer period and prolonged sunny spells. This will help prevent harmful UV rays from damaging and discolouring the material.

Ensure that the product is clean and dry before storage.

Clean your product with a sponge and warm soapy water then wipe with a clean, dry cloth.

Cushions should be cleaned following the care instruction on the label.

Where instructions as to the; storage, commissioning, installation, use and maintenance of the goods or (if there is none) good trade practice are not followed and a defect arises this will void the 12 month manufacturer's guarantee on the product.

✗ Don'ts

Do not use scourers, abrasives, washing powders, chemical cleaners or any other substances containing abrasives since these substances can damage the product, including the table top.

To preserve the table top design do not place greasy / oily items directly onto the surface. Use place-mats to prevent spillages of food or drink.

Do not place very hot or very cold items on the wooden surface unless adequately thick table-mats are used to prevent such items from coming into contact with the wood.

Do not use the table as a chopping surface.

Do not strike the table with hard or pointed items.

Do not sit or lean on the table.

Do not use power tools to construct this product.

Do not use this product if parts are missing, damaged or worn.

Do not stand or climb onto the product and do not use it as a ladder, as this could lead to it unbalancing and overturning.

Never tilt the chairs during use.

Never drag furniture when moving it, always lift it.

Number of people required for assembly

Two people



Time to assemble



40 minutes

Tools required



Tips: .

It is best not to fully tighten the nuts and bolts until they are all correctly located. Only carefully tighten them when you are satisfied with the alignment of all components.

Be careful not to overtighten.

Aspen Left and Right Hand Bench, Middle Sofa, Corner Sofa and Coffee Table Assembly Instructions

Maintenance Instructions for the Teak Wood

IMPORTANT, RETAIN FOR FUTURE REFERENCE READ CAREFULLY

Wooden furniture

Tropical hardwoods, such as teak and eucalyptus, are naturally weather resistant due to their high oil content. This makes pieces easy to look after, as you can keep them outside throughout the seasons.

Note that these hardwoods can develop cracks along the grain after they've been exposed to the elements.

Over time, teak will weather to a beautiful silvery grey colour. It's a natural timber so variations in colour and markings will occur from piece to piece.

How to care for it

Give your hardwood furniture a yearly scrub with soapy water, followed by a thorough rinse. This removes algae and pollution to restore the timber's surface, keeping it in good condition.

If you want your teak furniture to look less weathered, restore some of the original colour by applying cleaner, followed by brightener and finished off with teak oil. Make sure the timber is completely dry when you apply the teak oil, otherwise it can blacken.

Aspen Left and Right Hand Bench, Middle Sofa, Corner Sofa and Coffee Table

Assembly Instructions

This Dining Set is a combination set of 5 pieces.

Please find the combination part.

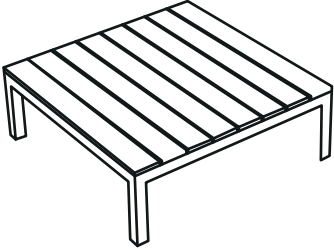
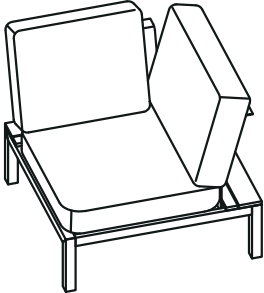
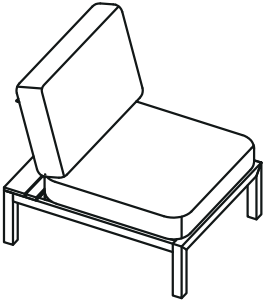
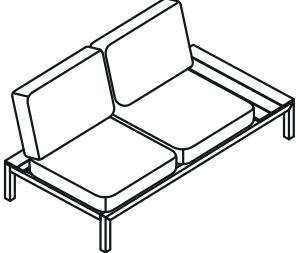
Combination Part No.	Diagram	Name	Qty.
1		Coffee Table	1 PC
2		Corner Sofa	1 PC
3		Middle Sofa	1 PC
4		Left Hand Bench	1 PC

Aspen Left and Right Hand Bench, Middle Sofa, Corner Sofa and Coffee Table

Assembly Instructions

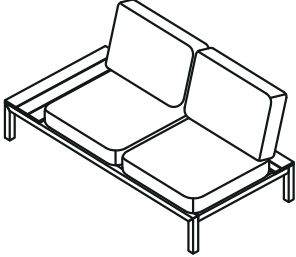
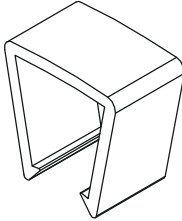
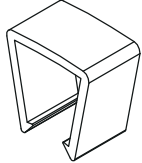
5		Right-Hand Bench	1 PC
6		Big Clip	2 PCS
7		Small Clip	4 PCS





In order to better use your Sofa, the Parts (2), (3), (4) and (5) should be connected together by clips (6, 7).

Note: The illustration is for reference only.

Aspen Left and Right Hand Bench, Middle Sofa, Corner Sofa and Coffee Table

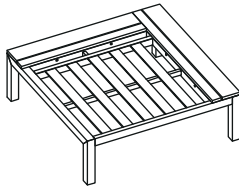
Assembly Instructions

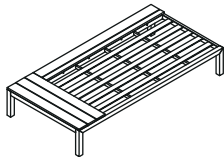
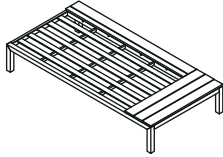
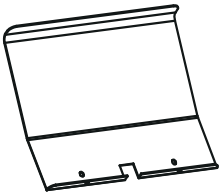

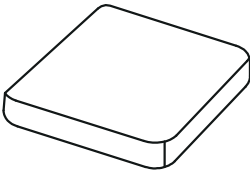
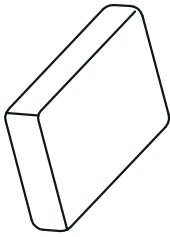

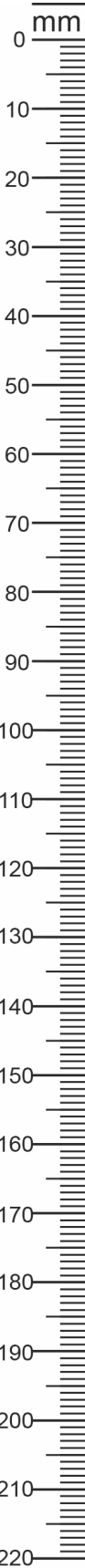
Components, fixtures & fittings (not actual size)

Parts List					
Part No.	Diagram	Qty.	Part No.	Diagram	Qty.
A	 Corner Sofa Seat	1 PC	B	 Middle Sofa Seat	1 PC
C	 Right Hand Bench	1 PC	D	 Left Hand Bench	1 PC
E	 Backrest	7 PCS	F	 Big Washer	14 PCS
G	 Seat Cushion	6 PCS	H1	 Big Backrest Cushion	6 PCS

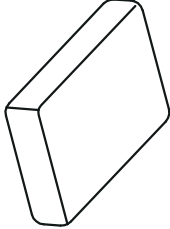

Aspen Left and Right Hand Bench, Middle Sofa, Corner Sofa and Coffee Table

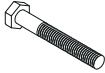
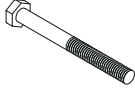
Assembly Instructions

H2	 Small Backrest Cushion	1 PC	N	 Nut	14 PCS
W20	 M6*20mm Bolt	14 PCS	W60	 M6*60mm Bolt	14 PCS
F3	 Flat Washer	28 PCS	S	 Spanner	2 PCS

Aspen Left and Right Hand Bench, Middle Sofa, Corner Sofa and Coffee Table

Assembly Instructions

Step by step assembly instructions

Part 1: Corner Sofa

Step One

Place the Corner Sofa Seat (A) upside down on a flat, non-abrasive surface of a work table to avoid scratching the surface or rim.

Assemble the Backrest (E) to the Corner Sofa Seat (A) using Flat Washers (F3) and Bolts (W20).

Please Note the Bolts (W20) are used vertically.

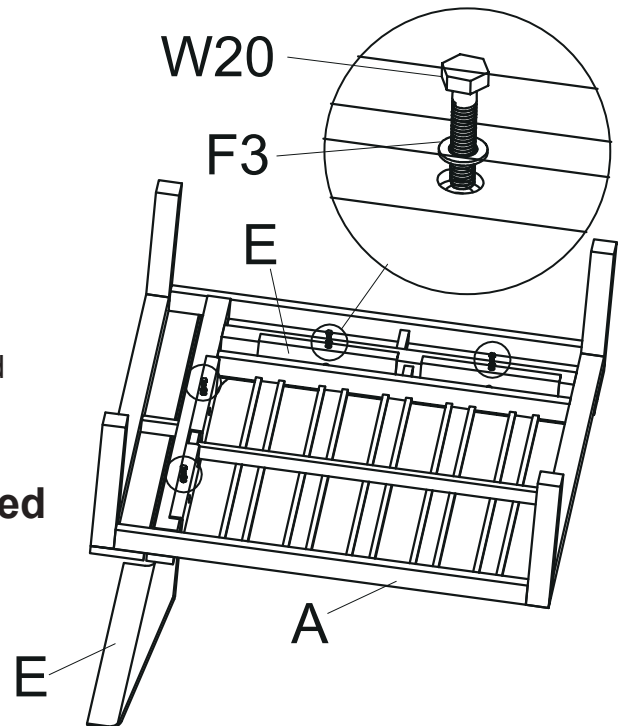

Step Two

Continually finish the assembly using Bolts (W60), Flat Washers (F3), Big Washer (F) and Nuts (N).

Please Note the Bolts (W60) are used horizontally.

Once you are satisfied with the alignment of the components carefully tighten all bolts using Spanner (S). Do not over-tighten.

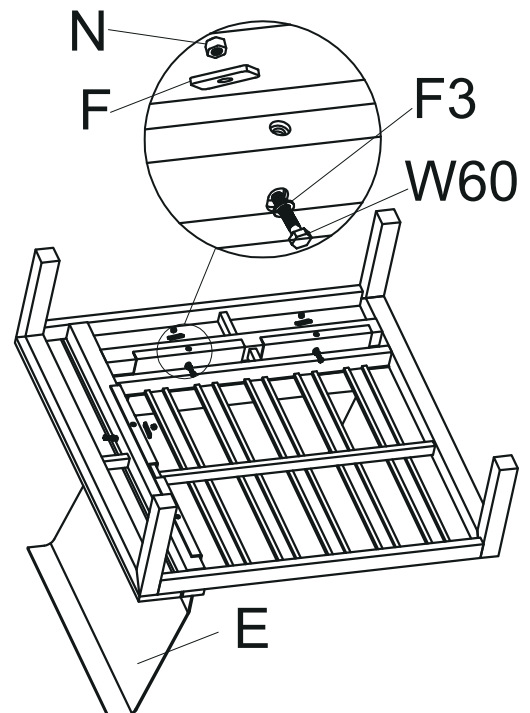

Aspen Left and Right Hand Bench, Middle Sofa, Corner Sofa and Coffee Table Assembly Instructions

Step Three

With the help of another person, stand the Corner Sofa in the upright position.

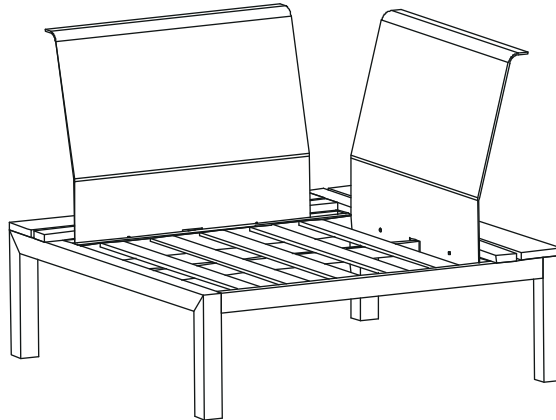

Part 2: Middle Sofa

Step One

Place the Middle Sofa Seat (B) on a flat, non-abrasive surface.

Assemble the Backrest (E) to the Middle Sofa Seat (B) using Flat Washers (F3) and Bolts (W20).

**Please Note the Bolts (W20)
are used vertically.**

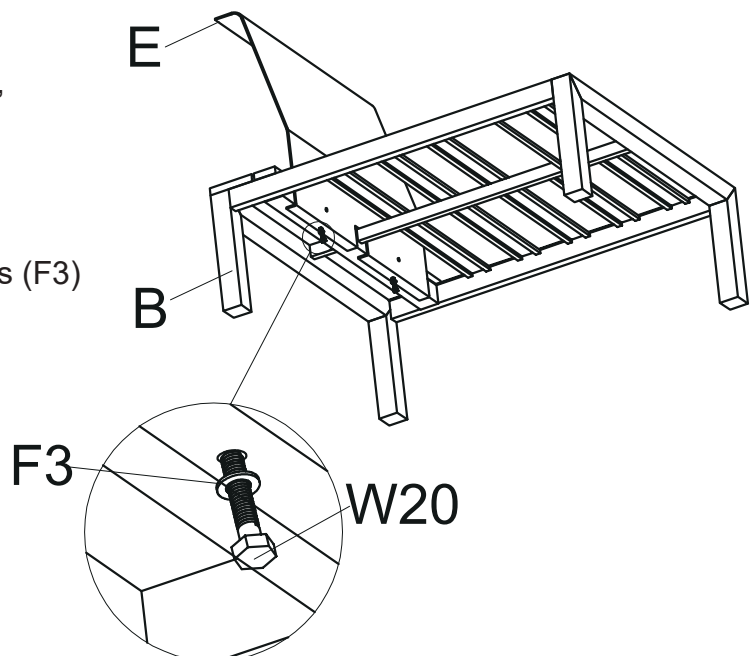

Aspen Left and Right Hand Bench, Middle Sofa, Corner Sofa and Coffee Table

Assembly Instructions

Step Two

Continually finish the assembly using Bolts (W60), Flat Washers (F3), Big Washer (F) and Nuts (N).

Please Note the Bolts (W60) are used horizontally.

Once you are satisfied with the alignment of the components carefully tighten all bolts using Spanner (S). Do not over-tighten.

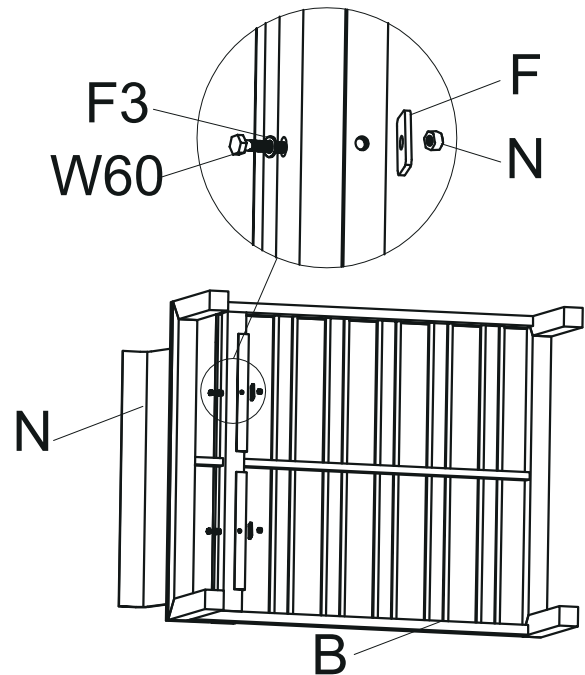

Step Three

With the help of another person, stand the Middle Sofa in the upright position.

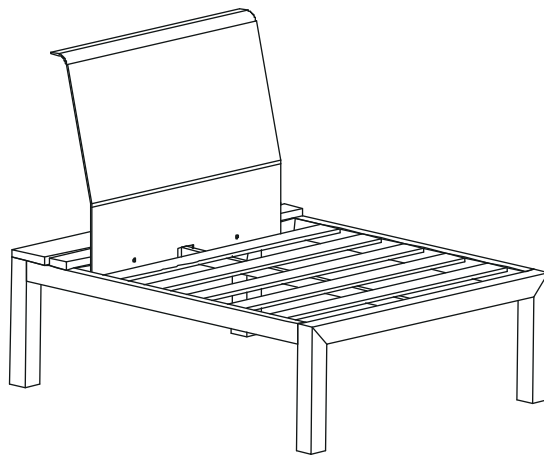

Aspen Left and Right Hand Bench, Middle Sofa, Corner Sofa and Coffee Table

Assembly Instructions

Part 3: Right Hand Bench

Step One

Place the Right Hand Bench Seat (C) on a flat, non-abrasive surface.

Assemble the Backrest (E) to the Right Hand Bench Seat (C) using Flat Washers (F3) and Bolts (W20).

Please Note the Bolts (W20) are used vertically.

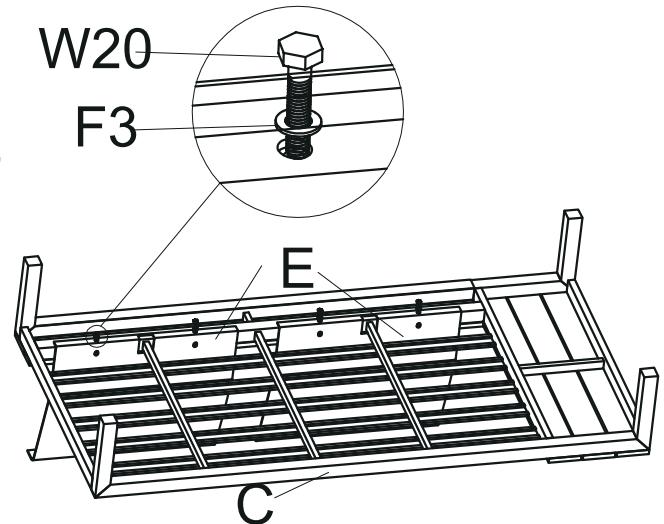

Step Two

Continually finish the assembly using Bolts (W60), Flat Washers (F3), Big Washer (F) and Nuts (N).

Please Note the Bolts (W60) are used horizontally.

Once you are satisfied with the alignment of the components carefully tighten all bolts using Spanner (S). Do not over-tighten.

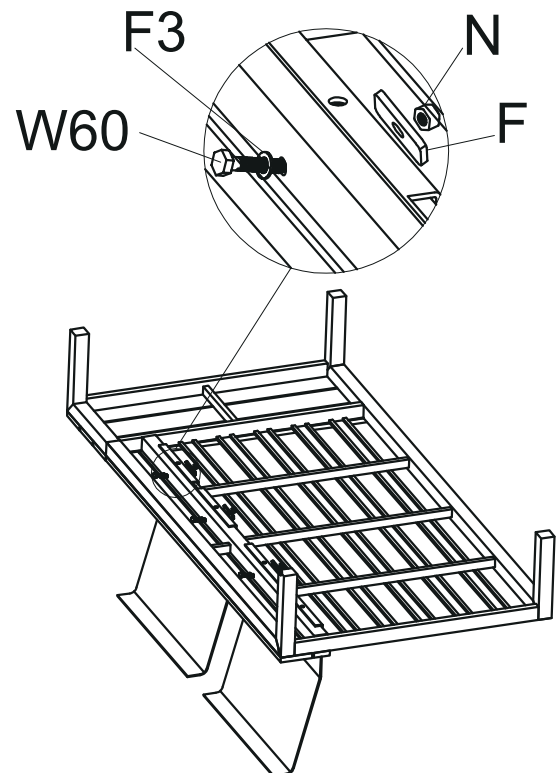

Aspen Left and Right Hand Bench, Middle Sofa, Corner Sofa and Coffee Table Assembly Instructions

Step Three

With the help of another person, stand the Right Hand Bench in the upright position.

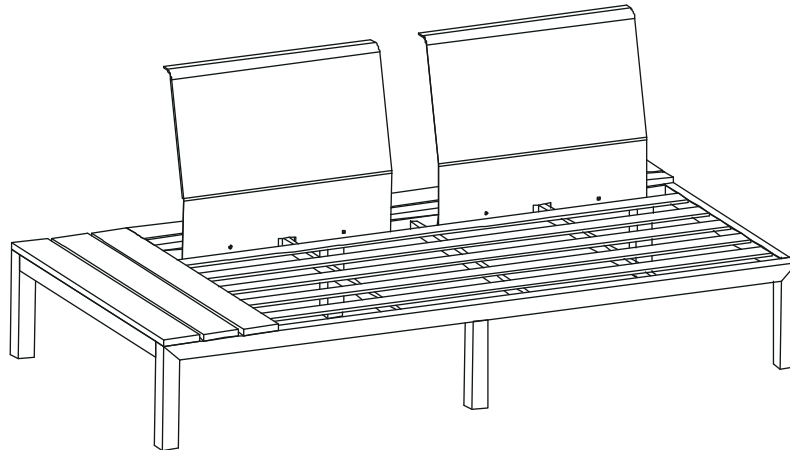

Part 4: Left Hand Bench

Repeat all Assembly Steps in Part 3 to finish the assembly of the Left Hand Bench and stand it in the upright position.

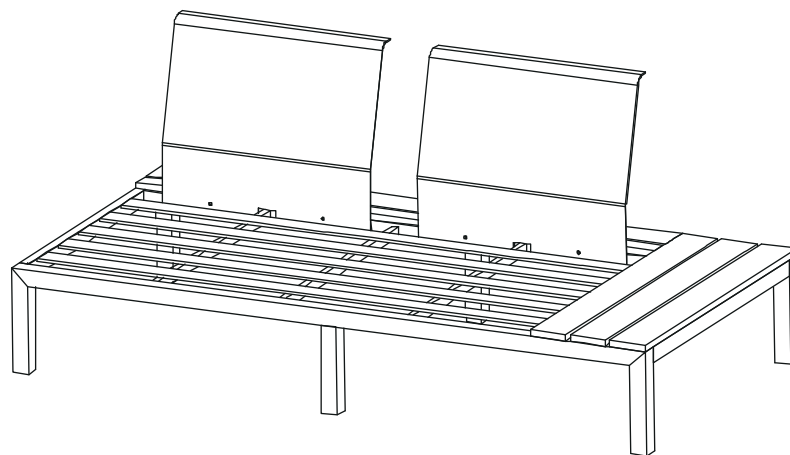

Part 5: In order to best suite for your Sofa Set, please combine all Parts with Clips (6) and (7) like below.

Aspen Left and Right Hand Bench, Middle Sofa, Corner Sofa and Coffee Table Assembly Instructions

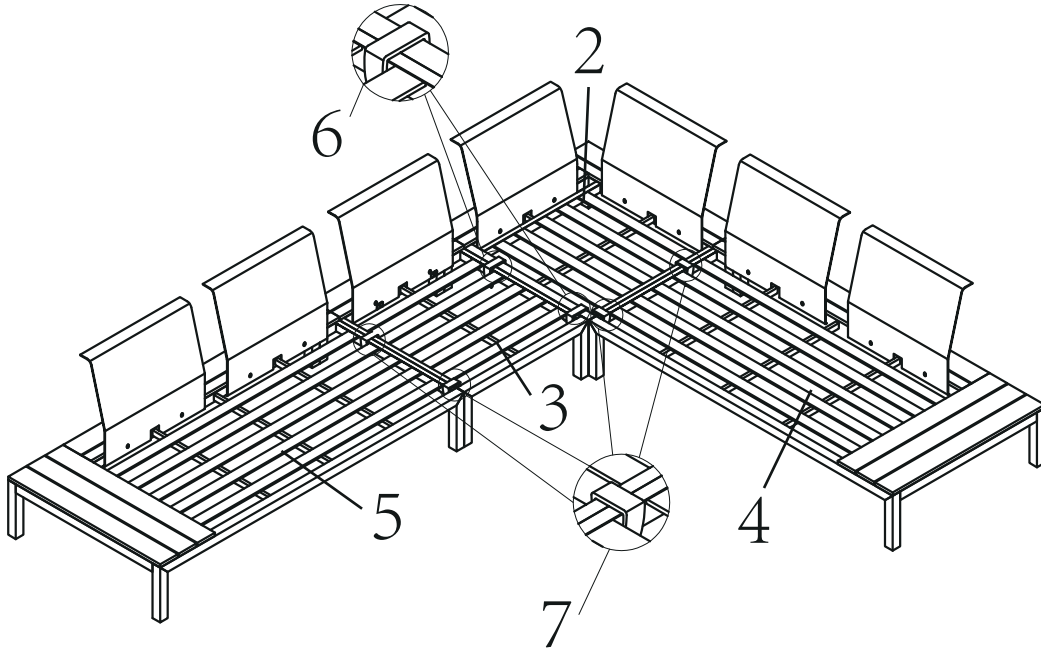

Part 6: Place the Seat Cushions (G), Big Backrest Cushions(H1) and Small Backrest Cushion (H2) to the Sofa Set, your product is now ready for use.

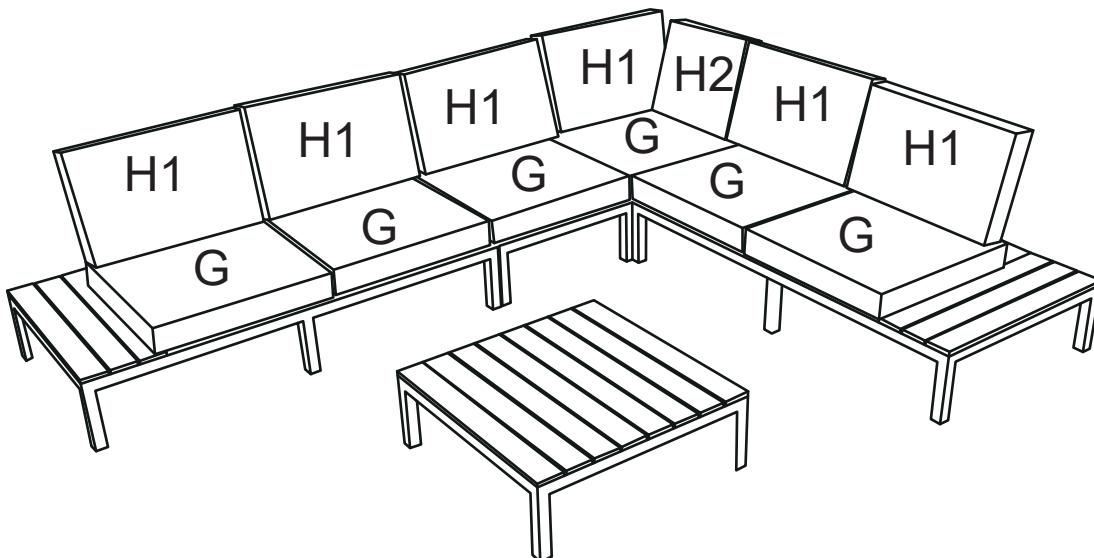

PLEASE KEEP THESE INSTRUCTIONS FOR FUTURE REFERENCE