

Product size:

Right Chair: W91\*D71\*H63/68 cm

Left Chair: W91\*D71\*H63/68 cm

Coffee Table: W40\*D71\*H50 cm

Footstool: W62\*D82\*H31/41 cm

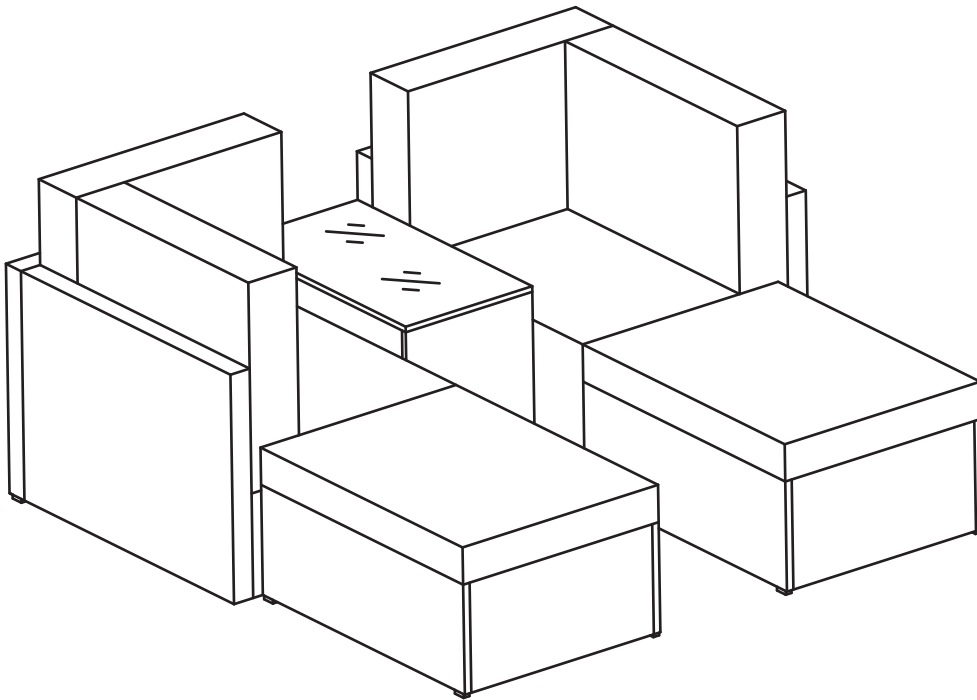

**Furniture should be covered/stored whilst not in use to prolong its longevity.  
(It should also be covered in adverse weather.)**

**The intended use of this product is for domestic use only!**

**Important, please retain for future reference.**

**Read carefully.**

# Berlin 4 Seater (5pcs) Multi Setting Relaxer Lounge Set Assembly Instructions

## Before you start



### Warnings

#### IMPORTANT, RETAIN FOR FUTURE REFERENCE READ CAREFULLY

See enclosed instructions for assembly, safety and care information.

Failure to follow the warnings could result in serious injury.

Handle heavy parts with care.

Ensure that this product is fully assembled as illustrated before use.

This product should only be used on firm, level ground.

Keep small parts out of reach of children.

Do not stand or climb onto this product.

This product is intended for **domestic use** only.

Furniture can be dangerous if incorrectly used. No liability will be accepted for damage or injury caused by incorrect use of this product.



### Dos

When you are ready to start, make sure that you have the right tools, plenty of space and a clean, dry area for assembly.

Unwrap all packaging materials and place the components on a suitable surface to prevent scratching your product.

Check all contents are present prior to assembly as per the parts list provided. In the event of problems or missing parts, please contact the seller.

Check all screws and bolts are tightened and inspect regularly.

Cover furniture when not in use to add additional protection to your product.

Store all cushions indoors after use as they are not waterproof.

During severe weather conditions, including high winds, rain, hail, thunderstorms, extreme heat and cold temperatures, the product should be stored inside in a cool, dry place.

To best preserve the synthetic rattan, please use a protective cover when your furniture is not in use. We would also recommend using a gazebo or parasol over your furniture during the summer period and prolonged sunny spells. This will help prevent harmful UV rays from damaging and discolouring the material.

Ensure that the product is clean and dry before storage.

Clean your product with a sponge and warm soapy water then wipe with a clean, dry cloth.

Cushions should be cleaned following the care instruction on the label.

Where instructions as to the; storage, commissioning, installation, use and maintenance of the goods or (if there is none) good trade practice are not followed and a defect arises this will void the 12 month manufacturer's guarantee on the product.



### Don'ts

Never tilt the chair during use.

Do not stand or climb onto the product.

Do not use power tools to construct this product.

Do not sit or lean onto the arms of this product.

Do not use this product if parts are missing, damaged or worn.

Do not use scourers, abrasives, washing powders, chemical cleaners or any other substances containing abrasives since these substances can damage the product.

To preserve the table top design do not place greasy / oily items directly onto the surface. Use place-mats to prevent spillages of food or drink.

Do not place very hot or very cold items on the glass surface unless adequately thick table-mats are used to prevent such items from coming into contact with the glass.

Do not use the table as a chopping surface.

Do not strike the table with hard or pointed items.

Do not sit or lean on the table.

Do not use this product as a ladder as this could lead to the product becoming unbalanced and overturning.

Do not place very hot or very cold items on this product surface.

Never drag furniture when moving it, always lift it.

### Number of people required for assembly

Two people



### Time to assemble

60 minutes

### Tools required



### Tips:

**Do NOT fully tighten bolts before all components are connected.**



**Only fully tighten once you are satisfied with the alignment of all components.**

**Do not overtighten bolts.**

# Berlin 4 Seater (5pcs) Multi Setting Relaxer Lounge Set Assembly Instructions

This Lounge Set is a set of 5 pieces.

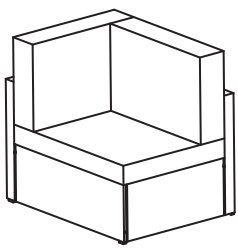
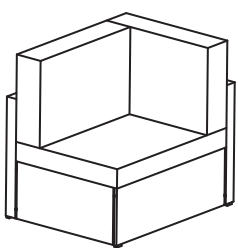
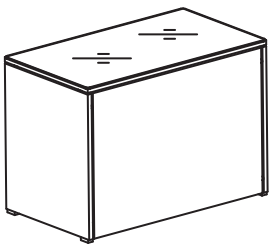
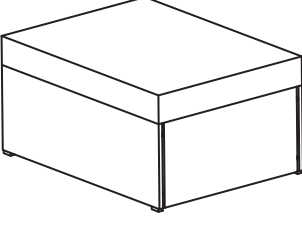

Please find the Components.

No.	Diagram	Name	Qty.
1		Right Chair	1 PC
2		Left Chair	1 PC
3		Coffee Table	1 PC
4		Footstool	2 PCS
5		Clip	8 PCS

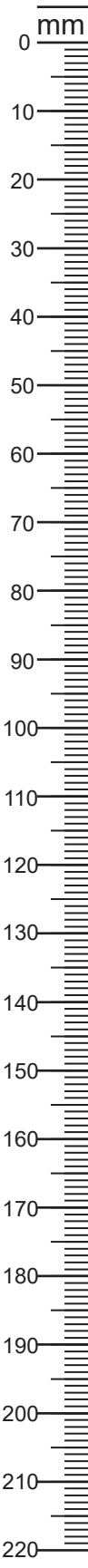

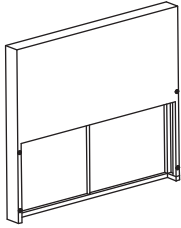
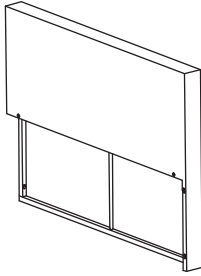
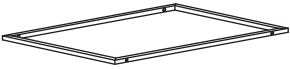
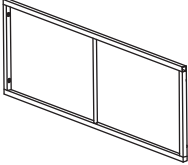
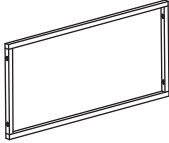
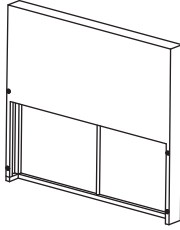
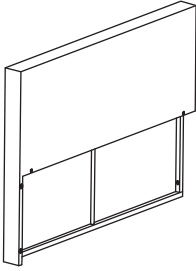

# Berlin 4 Seater (5pcs) Multi Setting Relaxer Lounge Set Assembly Instructions



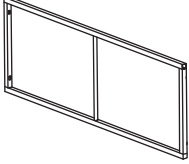
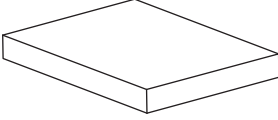
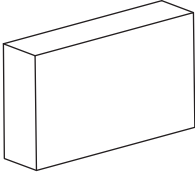
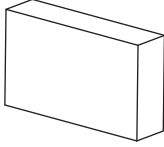
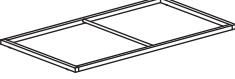
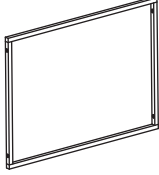

Parts, fixtures & fittings (not actual size)

Parts List					
Part No.	Diagram	Qty.	Part No.	Diagram	Qty.
A	 Right Leg	1 PC	B	 Backrest for Right Chair	1 PC
C	 Seat for Right Chair	1 PC	D	 Front Panel for Right Chair	1 PC
E	 Side Panel	2 PCS	F	 Left Leg	1 PC
G	 Backrest for Left Chair	1 PC	H	 Seat for Left Chair	1 PC

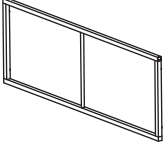
# Berlin 4 Seater (5pcs) Multi Setting Relaxer Lounge Set Assembly Instructions

I	 Front Panel for Left Chair	1 PC	J	 Seat Cushion	2 PCS
K	 Backrest Cushion	2 PCS	L	 Side Cushion	2 PCS
M	 Coffee Table Top	1 PC	N	 Coffee Table Long Panel	2 PCS
O	 Coffee Table Short Panel	2 PCS	P	 Glass Top	1 PC
Q	 Footstool Top	2 PCS	R	 Footstool Long Panel	4 PCS

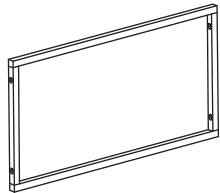
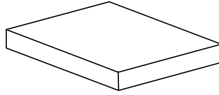
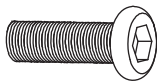
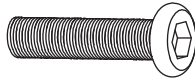
# Berlin 4 Seater (5pcs) Multi Setting Relaxer Lounge Set Assembly Instructions

S	 Footstool Short Panel	4 PCS	T	 Footstool Cushion	2 PCS
N35	 M6*35mm Bolt	44PCS	N45	 M6*45mm Bolt	16 PCS
F2	 Washer	60 PCS	AK	 Allen Key	2 PCS

## Component 1 – Right Chair: Assembly steps

### Step One

Loosely attach the Right Leg (A) to the Backrest for Right Chair (B) using Washers (F2) and Bolts (N35).

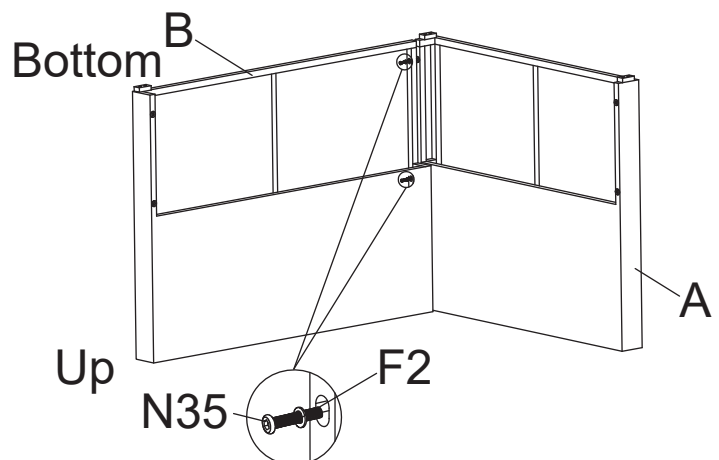

# Berlin 4 Seater (5pcs) Multi Setting Relaxer Lounge Set Assembly Instructions

## Step Two

Loosely attach the Seat for Right Chair (C) to the Backrest for Right Chair (B) using Washers (F2) and Bolts (N45).

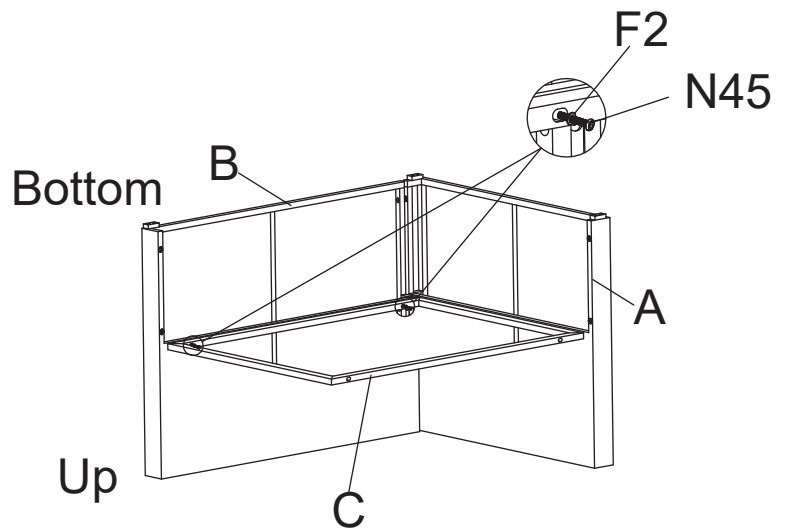

## Step Three

Loosely attach the Front Panel for Right Chair (D) to the above partly-assembled parts using Washers (F2) and Bolts (N35 & N45).

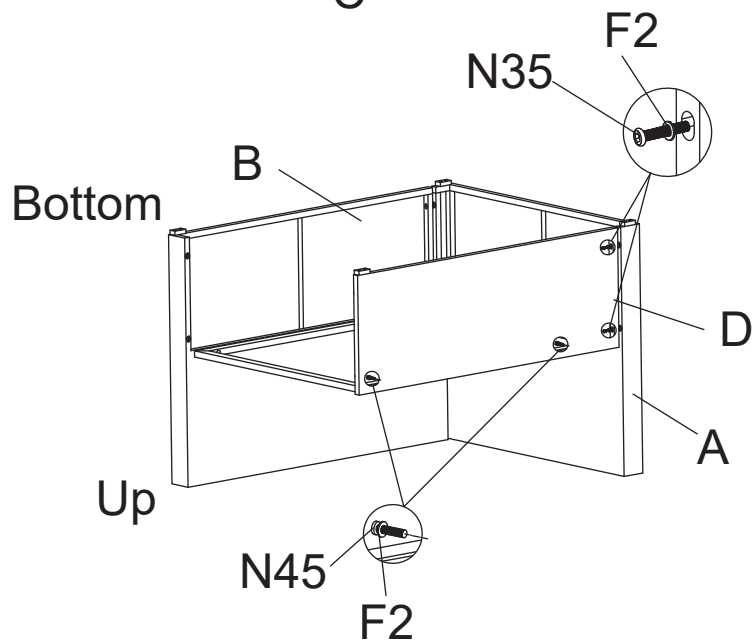

## Step Four

Loosely attach the Side Panel for Right Chair (E) to the above partly-assembled parts using Washers (F2) and Bolts (N35).

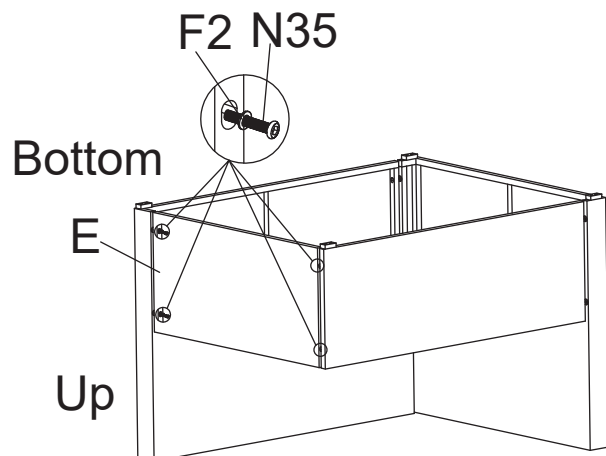

# Berlin 4 Seater (5pcs) Multi Setting Relaxer Lounge Set Assembly Instructions

## Step Five

With the help of another person, turn over the Right Chair in the upright position.

Please don't place the Cushions until all components are connected.

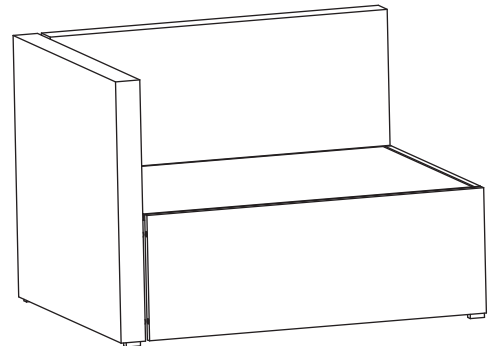

## Component 2 – Left Chair: Assembly Steps

### Step One

Loosely attach the Left Leg (F) to the Backrest for Left Chair (G) using Washers (F2) and Bolts (N35).

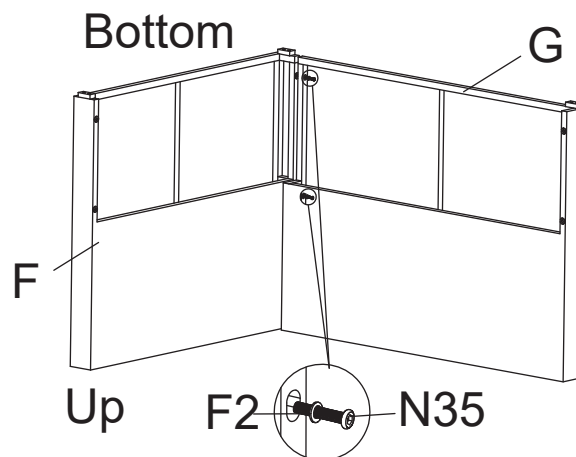

### Step Two

Loosely attach the Seat for Left Chair (H) to the Backrest for Left Chair (G) using Washers (F2) and Bolts (N45).

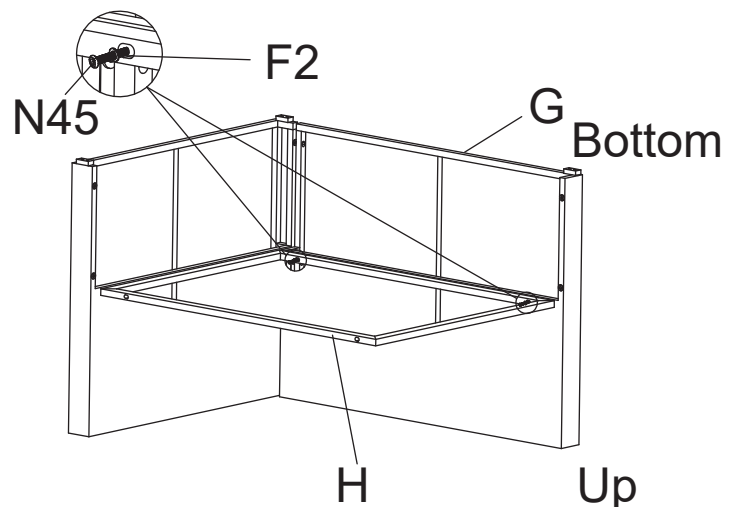

# Berlin 4 Seater (5pcs) Multi Setting Relaxer Lounge Set Assembly Instructions

## Step Three

Loosely attach the Front Panel for Left Chair (I) to the above partly-assembled parts using Washers (F2) and Bolts (N35 & N45).

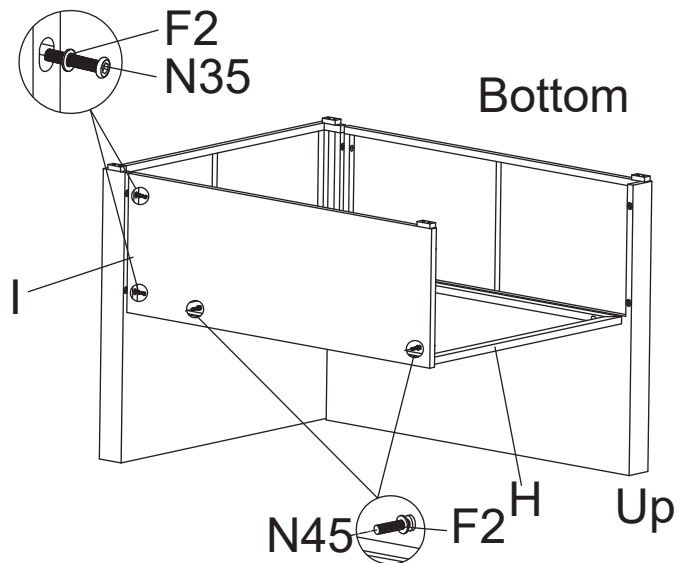

## Step Four

Loosely attach the Side Panel for Left Chair (E) to the above partly-assembled parts using Washers (F2) and Bolts (N35).

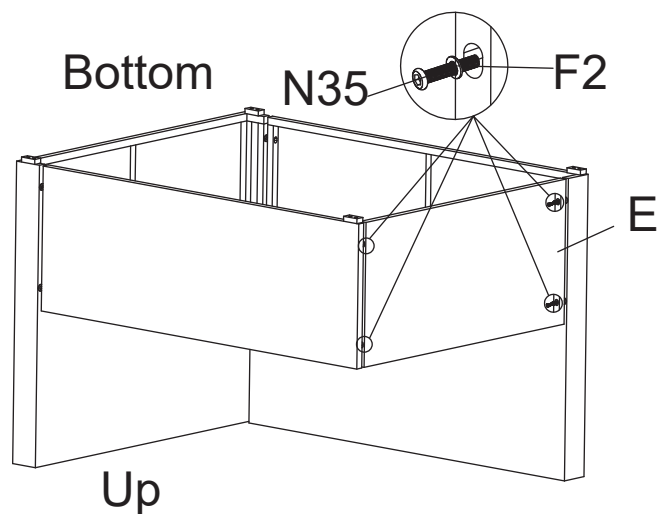

## Step Five

With the help of another person, turn over the Left Chair in the upright position.

Please don't place the Cushions until all components are connected.

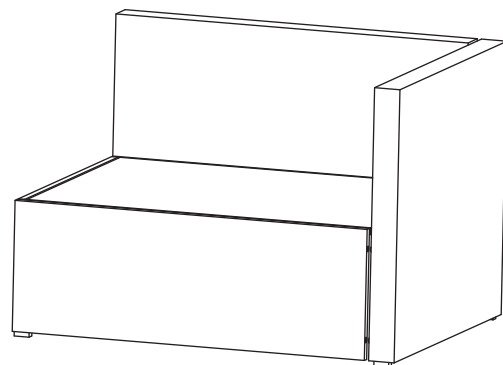

# Berlin 4 Seater (5pcs) Multi Setting Relaxer Lounge Set Assembly Instructions

## Component 3 – Coffee Table: Assembly Steps

### Step One

With the help of another person, loosely attach the Coffee Table Short Panels (O) to the Coffee Table Long Panels (N) using Washers (F2) and Bolts (N35).

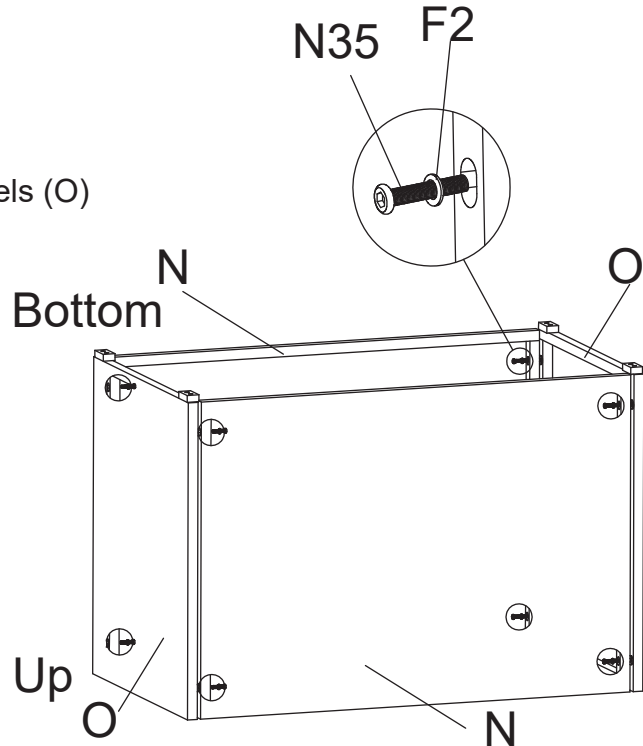

### Step Two

With the help of another person, loosely attach the above partly-assembled parts to the Coffee Table Top (M) using Washers (F2) and Bolts (N35).

Only tighten the bolts when all bolts and washers are in place and turn freely. Once you are satisfied with the alignment of the components carefully tighten all bolts using Allen Key (AK). Do not over-tighten.

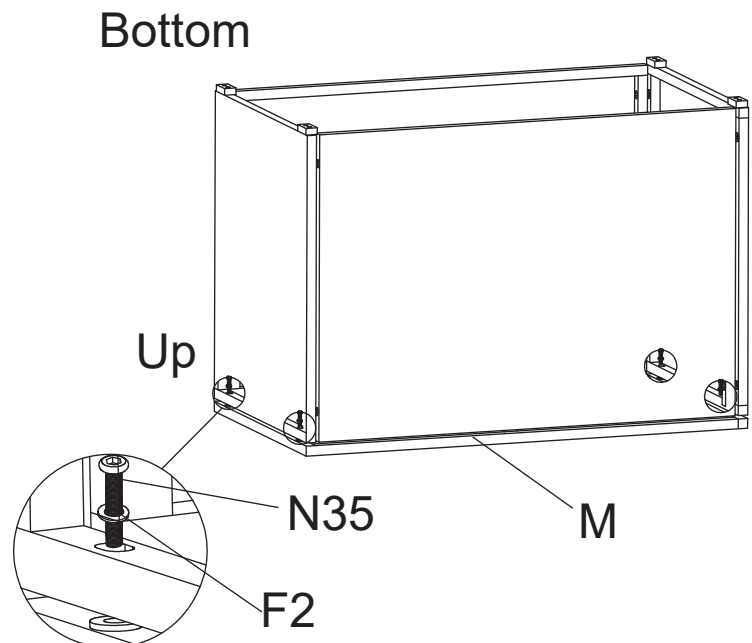

# Berlin 4 Seater (5pcs) Multi Setting Relaxer Lounge Set Assembly Instructions

## Step Three

With the help of another person, carefully turn over the coffee table frame in the upright position.

Don't place the Glass Top (P) on the Coffee Table Top (M) until all components are connected.

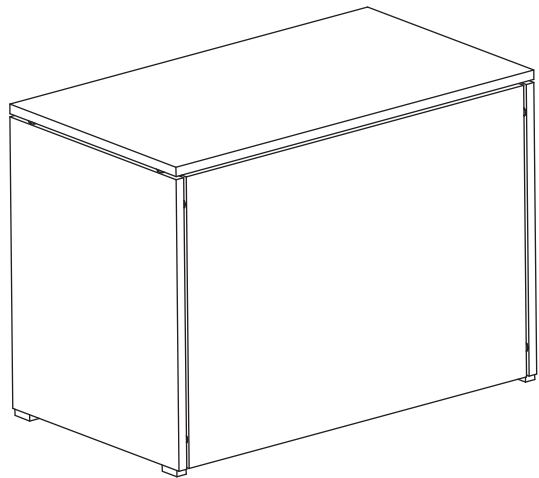

## Component 4 – Footstool: Assembly Steps

### Step One

With the help of another person, loosely attach the Footstool Short Panels (S) to the Footstool Long Panel (R) using Washers (F2) and Bolts (N35).

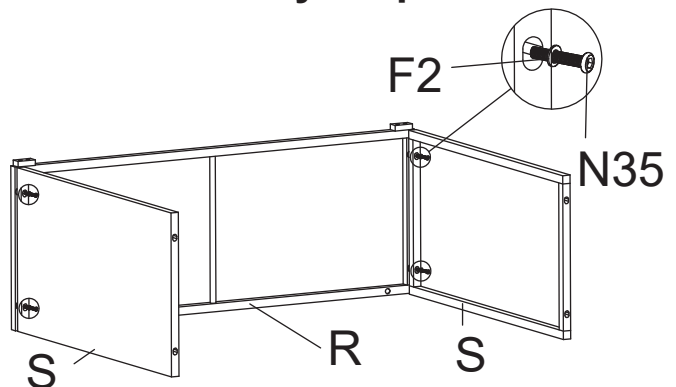

### Step Two

With the help of another person, loosely attach the Footstool Top (Q) to the Footstool Long Panel (R) using Washers (F2) and Bolts (N45).

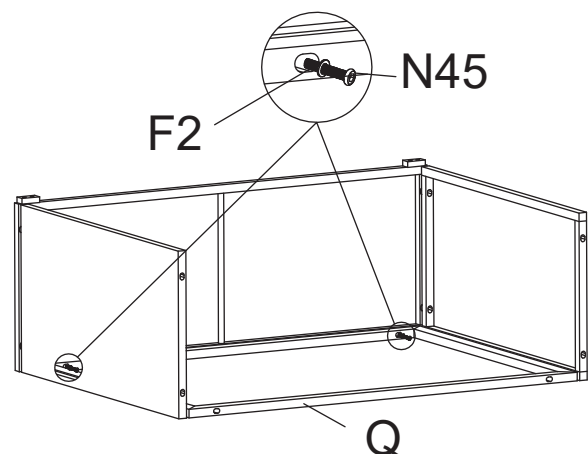

[www.royalcraft.co.uk](http://www.royalcraft.co.uk)

# Berlin 4 Seater (5pcs) Multi Setting Relaxer Lounge Set Assembly Instructions

## Step Three

With the help of another person, loosely attach the Footstool Long Panel (R) to the Footstool Top (Q) using Washers (F2) and Bolts (N45).

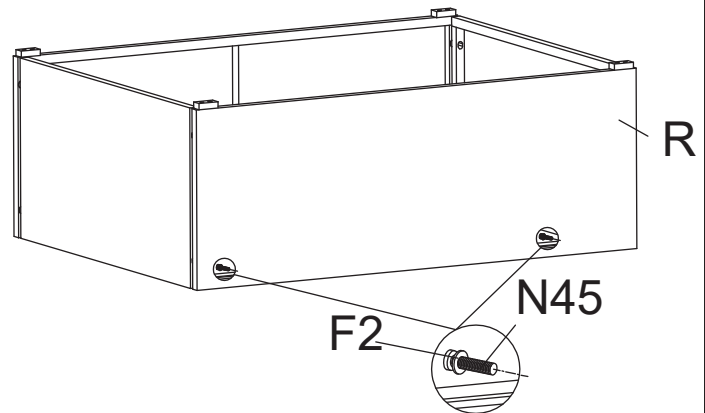

## Step Four

Loosely attach the Footstool Long Panel (R) to the Footstool Short Panels (S) using Washers (F2) and Bolts (N35).

Only tighten the bolts when all bolts and washers are in place and turn freely. Once you are satisfied with the alignment of the components carefully tighten all bolts using Allen Key (AK). Do not over-tighten.

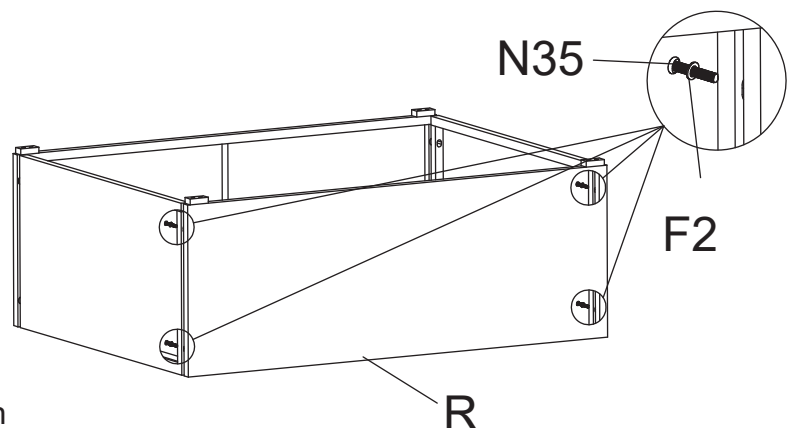

## Step Five

Connect all Components 1, 2, 3, 4 with Clips (CL).

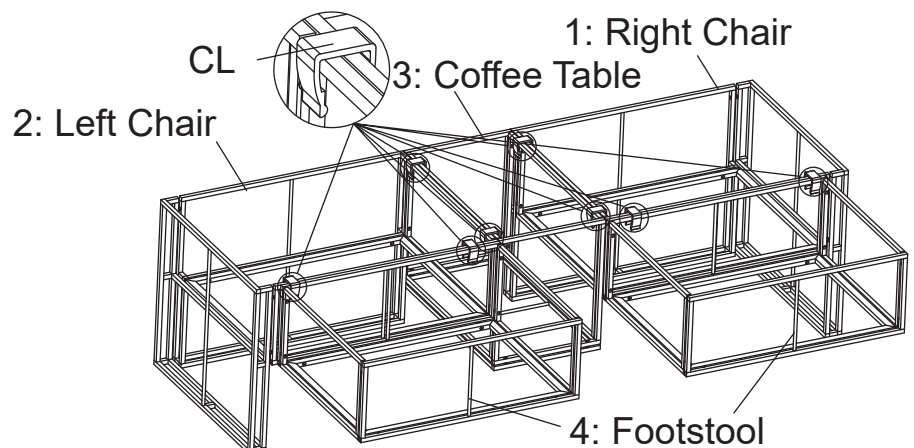

# Berlin 4 Seater (5pcs) Multi Setting Relaxer Lounge Set Assembly Instructions

## Step Six

With the help of another person, turn over the Lounge components.

Place the Cushion (J, K, L, T) to the Lounge Set.

Place the Glass (P) onto the Coffee Table Top (M).

Your Lounge Set is now ready for use.

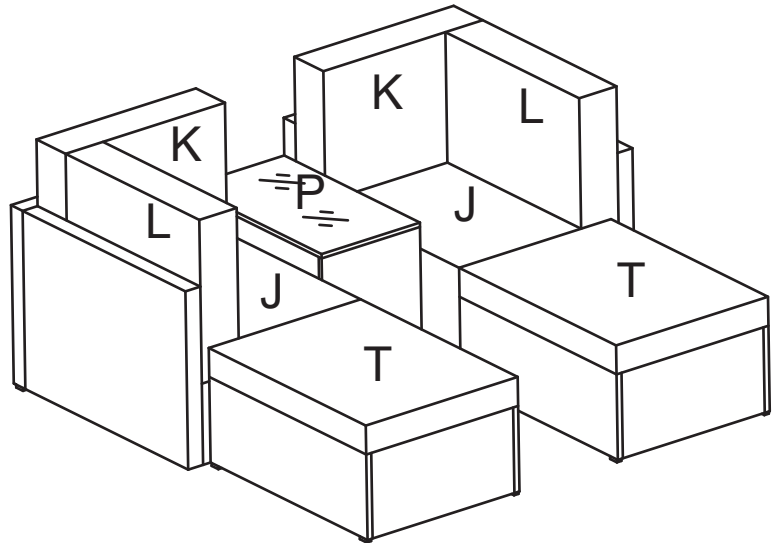

Never tilt the products during use.  
Ensure the product is always placed firmly  
on the ground.

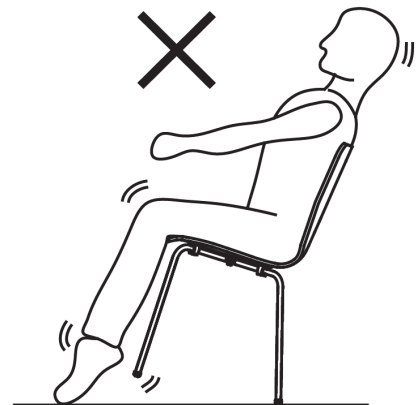

Ensure the product is always placed firmly on the ground.

**PLEASE KEEP THESE INSTRUCTIONS FOR FUTURE REFERENCE**