

Product size:
W170*D113.5*H75.5 cm

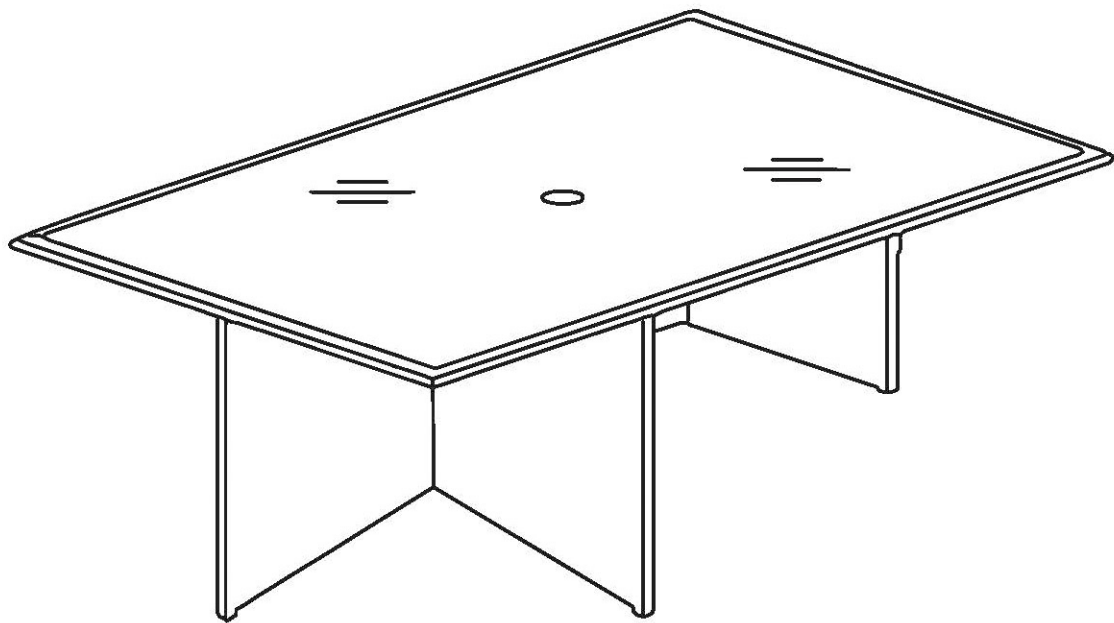

**Furniture should be covered/stored whilst not in use to prolong its longevity.
(It should also be covered in adverse weather.)**

The intended use of this product is for Domestic use only.

Important, please retain for future reference.

Read carefully.

Before you start

Warnings

IMPORTANT, RETAIN FOR FUTURE REFERENCE READ CAREFULLY

See enclosed instructions for assembly, safety and care information.

Failure to follow the warnings could result in serious injury.

Handle heavy parts with care.

Ensure that this product is fully assembled as illustrated before use.

This product should only be used on firm, level ground.

Keep small parts out of reach of children.

Do not stand or climb onto this product.

This product is intended for **domestic use** only.

Furniture can be dangerous if incorrectly used. No liability will be accepted for damage or injury caused by incorrect use of this product.

Dos

When you are ready to start, make sure that you have the right tools, plenty of space and a clean, dry area for assembly.

Unwrap all packaging materials and place the components on a suitable surface to prevent scratching your product.

Check the pack and make sure you have all parts listed. In the event of problems or missing parts, please contact the seller.

Check all screws and bolts are tightened and inspect regularly.

This product is suitable for all year outdoor use. However, to prolong its life we recommend that during severe weather conditions, including high winds, rain, hail, thunderstorms, extreme heat and cold temperatures, the product should be stored inside in a cool, dry place.

To best preserve the synthetic rattan, please use a protective cover when your furniture is not in use. We would also recommend using a gazebo or parasol over your furniture during the summer period and prolonged sunny spells. This will help prevent harmful UV rays from damaging and discolouring the material.

Ensure that the product is clean and dry before storage.

Clean your product with a sponge and warm soapy water then wipe with a clean, dry cloth.

When cleaning glass panels use a damp cloth or leather with washing up liquid or soft soap if necessary.

Where instructions as to the; storage, commissioning, installation, use and maintenance of the goods or (if there is none) good trade practice are not followed and a defect arises this will void the 12 month manufacturer's guarantee on the product.

Don'ts

Do not use scourers, abrasives, washing powders, chemical cleaners or any other substances containing abrasives since these substances can damage the product, including the glass panel.

To preserve the table top design do not place greasy / oily items directly onto the surface. Use place-mats to prevent spillages of food or drink.

Do not place very hot or very cold items on the glass surface unless adequately thick table-mats are used to prevent such items from coming into contact with the glass.

Do not use the table as a chopping surface.

Do not strike the table with hard or pointed items.

Do not sit or lean on the table.

Do not use power tools to construct this product.

Do not use this product if parts are missing, damaged or worn.

Do not stand or climb onto the product and do not use it as a ladder, as this could lead to it unbalancing and overturning.

Never drag furniture when moving it, always lift it.

Number of people required for assembly

Two people.



Time to assemble



30 Minutes

Tools required







Tips:

It is best not to fully tighten the nuts and bolts until they are all correctly located. Only carefully tighten them when you are satisfied with the alignment of all components.

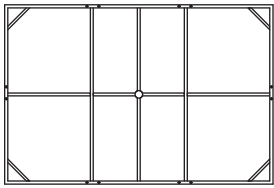
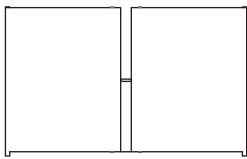
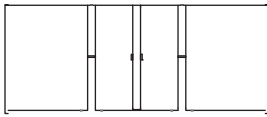
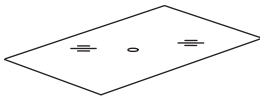
Be careful not to overtighten.

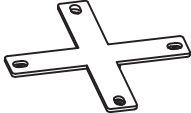
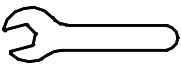
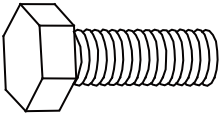
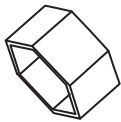
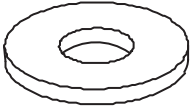
Components, fixtures & fittings (not actual size)

Parts List					
Part No.	Diagram	Qty.	Part No.	Diagram	Qty.
A	 Table Top Frame	1 PC	B	 Short Leg	2 PCS
C	 Long Leg	1 PC	D	 Glass Top	1 PC
E	 Connecting Panel	2 PCS	F	 Connecting Panel	2 PCS
S1	 Spanner	1 PC	W15	 M6*15mm Bolt	26 PCS
F2	 Bolt Head Cap	26 PCS	F3	 Flat Washer	26 PCS
F4	 Spring Washer	26 PCS			



Step by step assembly instructions

All Bolt Head Caps should not be attached before finally tightening all Bolts with Spanner.

Step One

Open the packaging, take out the contents and carefully leave the glass on the carton until the rest of the table is fully assembled.

With the help of another person, place the Table Top Frame (A) upside down on a flat, non-abrasive surface to avoid scratching the table surface or rim.

Do NOT assemble the Legs (B&C) to the Table Top Frame (A) while it is still resting on the Glass Top (D).

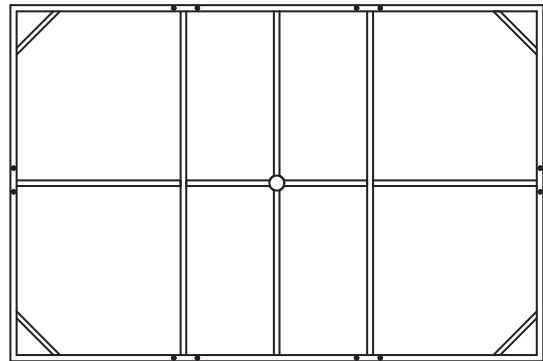

Step Two

With the help of another person, place the Long Leg (C) through the Short Legs (B), combine them by Connecting Panel (E) using Flat Washers (F3), Spring Washers (F4), Bolts (W15) and Bolt Head Caps (F2).

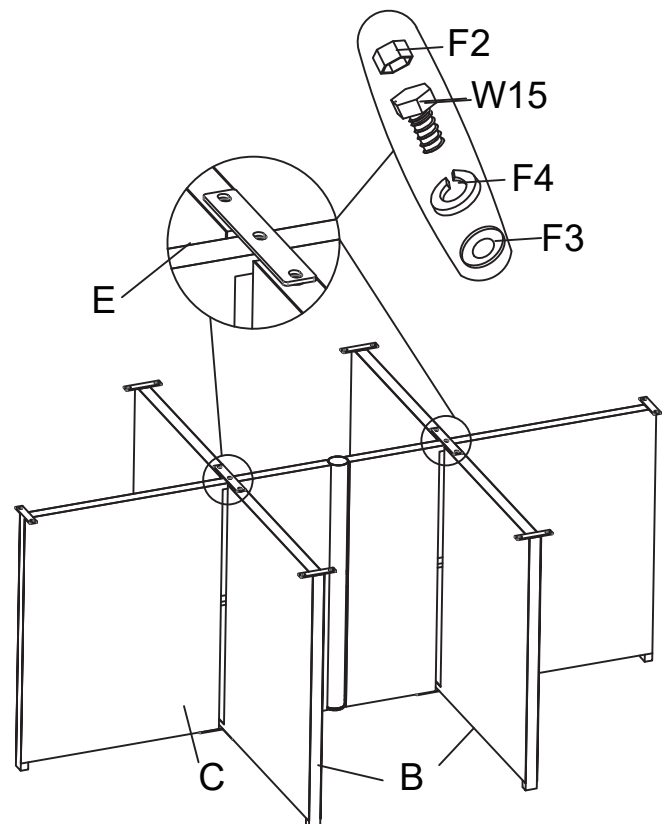

Step Three

With the help of another person, turn over the above partly-assembled parts, combine them by Connecting Panel (F) using the Flat Washers (F3), Spring Washers (F4), Bolts (W15) and Bolt Head Caps (F2).

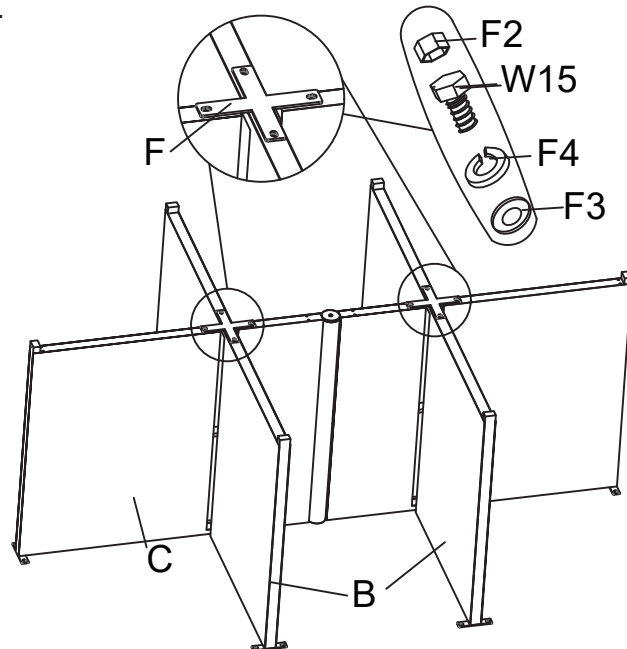

Step Four

With the help of another person, place the above partly-assembled parts onto the Table Top Frame (A) using the Flat Washers (F3), Spring Washers (F4), Bolts (W15) and Bolt Head Caps (F2).

Once you are satisfied with the alignment of all components, carefully tighten all bolts using Spanner (S1), cover all Bolt Heads with Bolt Head Caps (F2).

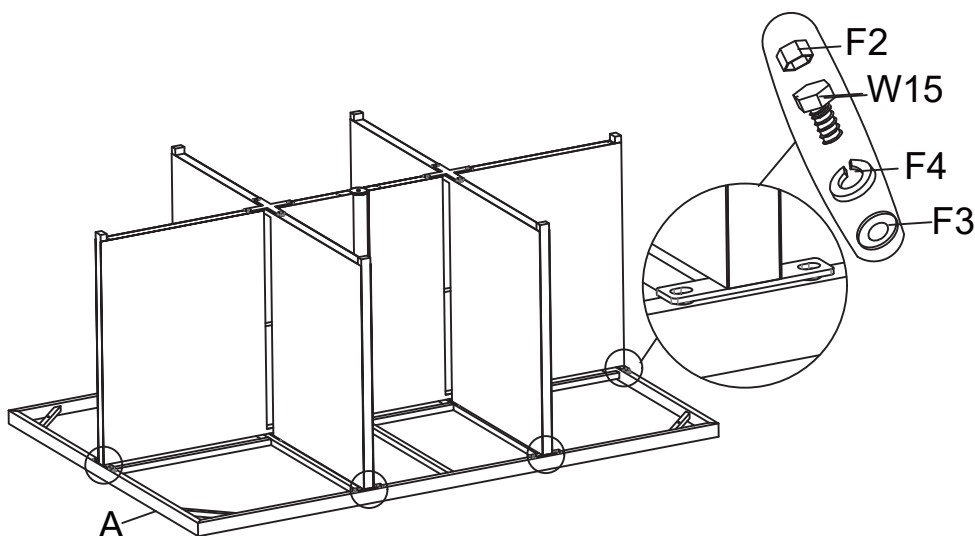

Step Five

With the help of another person, carefully lift the partly-assembled table in upright position. Level the table with adjustable feet screws.

During this step (Levelling step and Bolts-tightening step), you may have to try for several times.

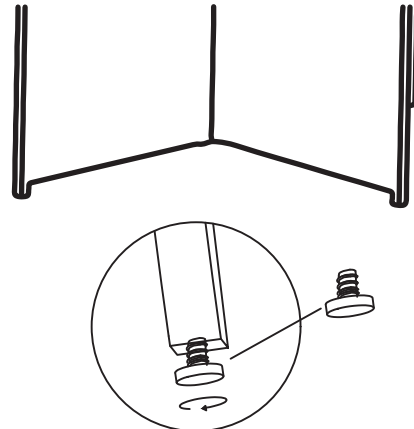

Adjustable Foot Screw

Step Six

With the help of another person, carefully lift the Glass Top (D) and place it onto the Table Top Frame (A).

The glass top should be securely inlaid into the Table Top Frame (A).

Make sure the glass top is evenly rested on the rubber pads which are pre-equipped on the inner edge of the Table Top Frame (A).

Your table is now ready for use.

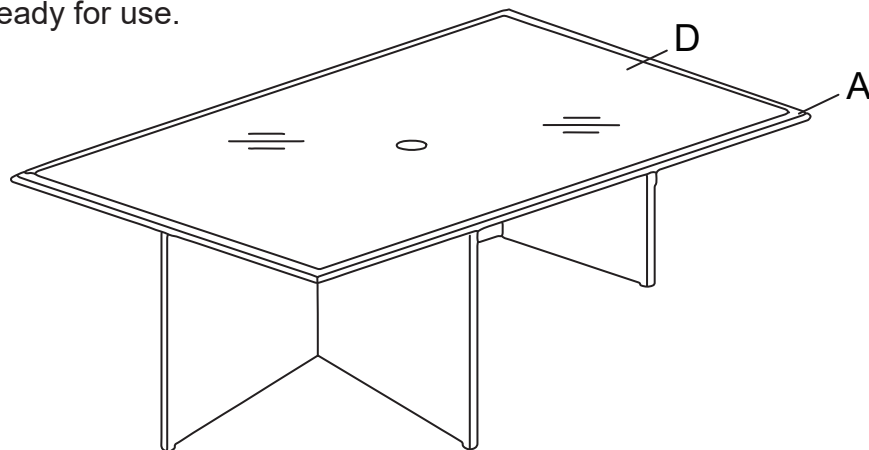

Note: If a parasol is used together with this Table, during high winds, the Parasol should be taken away and store in a safe place.

PLEASE KEEP THESE INSTRUCTIONS FOR FUTURE REFERENCE

Product size:
W54*D57.5*H86 cm

6

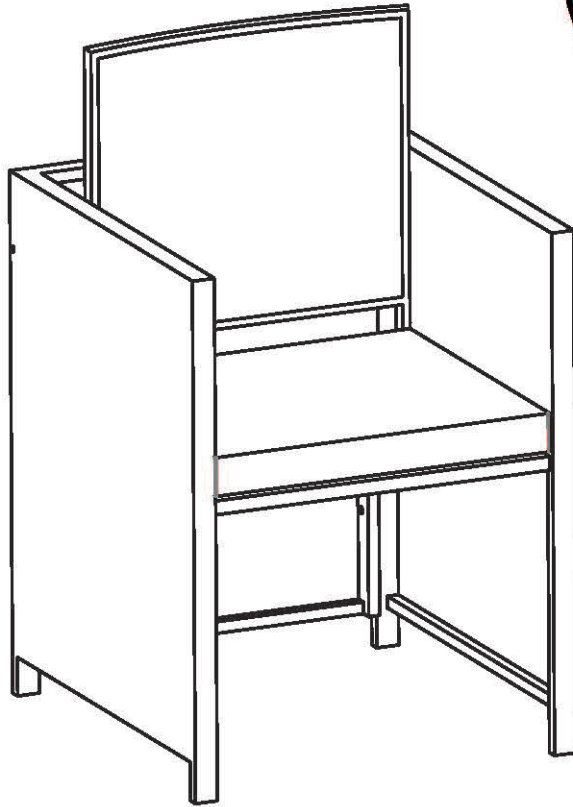

**Furniture should be covered/stored whilst not in use to prolong its longevity.
(It should also be covered in adverse weather.)**

The intended use of this product is for Domestic use only.

Important, please retain for future reference.

Read carefully.

Before you start

Warnings

IMPORTANT, RETAIN FOR FUTURE REFERENCE READ CAREFULLY

See enclosed instructions for assembly, safety and care information.

Failure to follow the warnings could result in serious injury.

Handle heavy parts with care.

Ensure that this product is fully assembled as illustrated before use.

This product should only be used on firm, level ground.

Keep small parts out of reach of children.

Do not stand or climb onto this product.

This product is intended for **domestic use** only.

Ensure the product is always placed on level ground.

Furniture can be dangerous if incorrectly used. No liability will be accepted for damage or injury caused by incorrect use of this product.

Dos

When you are ready to start, make sure that you have the right tools, plenty of space and a clean, dry area for assembly.

Unwrap all packaging materials and place the components on a suitable surface to prevent scratching your product.

Check the pack and make sure you have all parts listed. In the event of problems or missing parts, please contact the seller.

Check all screws and bolts are tightened and inspect regularly.

Store all cushions indoors after use as they are not waterproof.

This product is suitable for all year outdoor use. However, to prolong its life we recommend that during severe weather conditions, including high winds, rain, hail, thunderstorms, extreme heat and cold temperatures, the product should be stored inside in a cool, dry place.

To best preserve the synthetic rattan, please use a protective cover when your furniture is not in use. We would also recommend using a gazebo or parasol over your furniture during the summer period and prolonged sunny spells. This will help prevent harmful UV rays from damaging and discolouring the material.

Ensure that the product is clean and dry before storage.

Clean your product with a sponge and warm soapy water then wipe with a clean, dry cloth.

Cushions should be cleaned following the care instruction on the label.

Where instructions as to the; storage, commissioning, installation, use and maintenance of the goods or (if there is none) good trade practice are not followed and a defect arises this will void the 12 month manufacturer's guarantee on the product.

Don'ts

Never tilt the chair during use.

Do not stand or climb onto the product.

Do not use power tools to construct this product.

Do not sit or lean onto the arms of this product.

Do not use this product if parts are missing, damaged or worn.

Do not use scourers, abrasives, washing powders, chemical cleaners or any other substances containing abrasives since these substances can damage the product.

Do not use this product as a ladder as this could lead to the product becoming unbalanced and overturning.

Do not place very hot or very cold items on the product surface.

Never drag furniture when moving it, always lift it.

Number of people required for assembly

Two People



Time to assemble



10 minutes per chair

Tools required



Tips:





It is best not to fully tighten the nuts and bolts until they are all correctly located. Only carefully tighten them when you are satisfied with the alignment of all components.

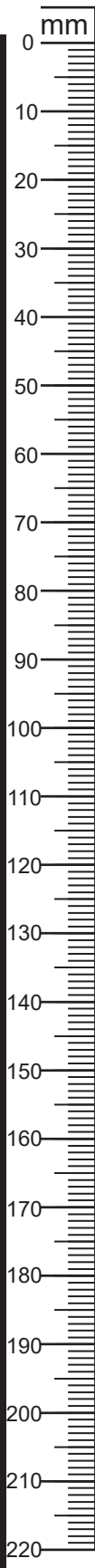

Be careful not to overtighten.

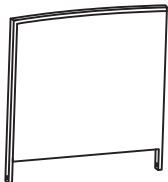
Components, fixtures & fittings (not actual size)

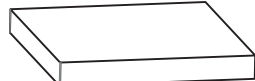
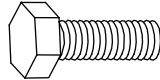
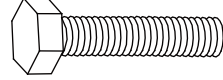
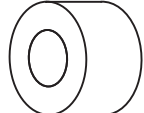
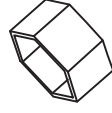

Parts List

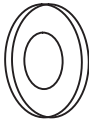
Part No.	Diagram	Qty.	Part No.	Diagram	Qty.
A	 Back Panel	4 PCS	B	 Foldable Backrest	4 PCS
C	 Left Armrest/Leg	4 PCS	D	 Right Armrest/Leg	4 PCS
E	 Seat Panel	4 PCS	F	 Cushion	4 PCS
W35	 M6*35mm Bolt	36 PCS	W50	 M6*50mm Bolt	8 PCS
F1	 Plastic Spacer	8 PCS	F2	 Bolt Head Cap	44 PCS

F3	 Flat Washer	44 PCS	F4	 Spring Washer	44 PCS
S1	 Spanner	1 PC			

Please note the diagram is for reference only, it may not fully represent the actual appearance of the parts.

The quantity marked is for 4 PCS Chairs.

Bolt Head Caps can only be attached when all Bolts are tightened with Spanner (S1).

Step by step assembly instructions

Step One

Attach Backrest (A) with Left Armrest/Leg(C) & Right Armrest/Leg (D) together using Flat Washers (F3), Spring Washers (F4), Bolts (W35), Bolts (W50) and Bolt Head Caps (F2).

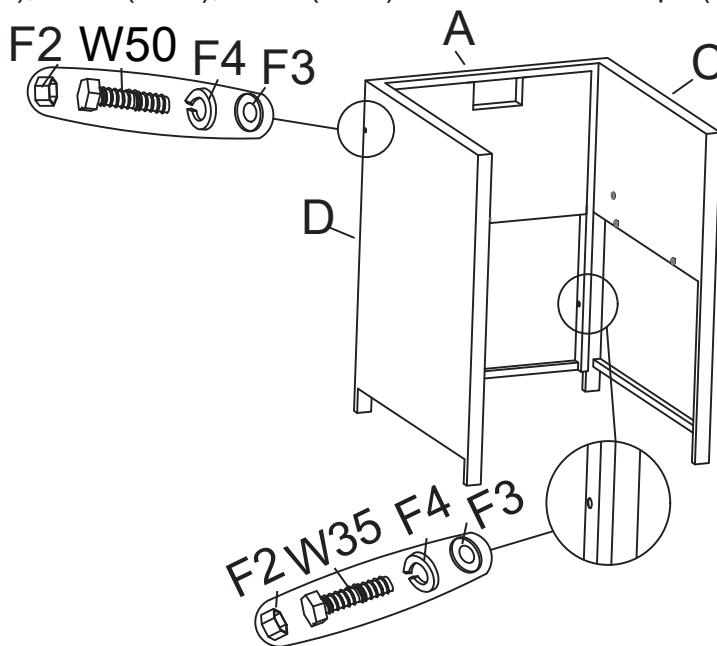

Please note the Longer Bolts (W50) should be used on the top side.

Step Two

Attach Seat Panel (E) to the above partly-assembled parts using Flat Washers (F3), Spring Washers (F4), Bolts (W35) and Bolt Head Caps (F2).

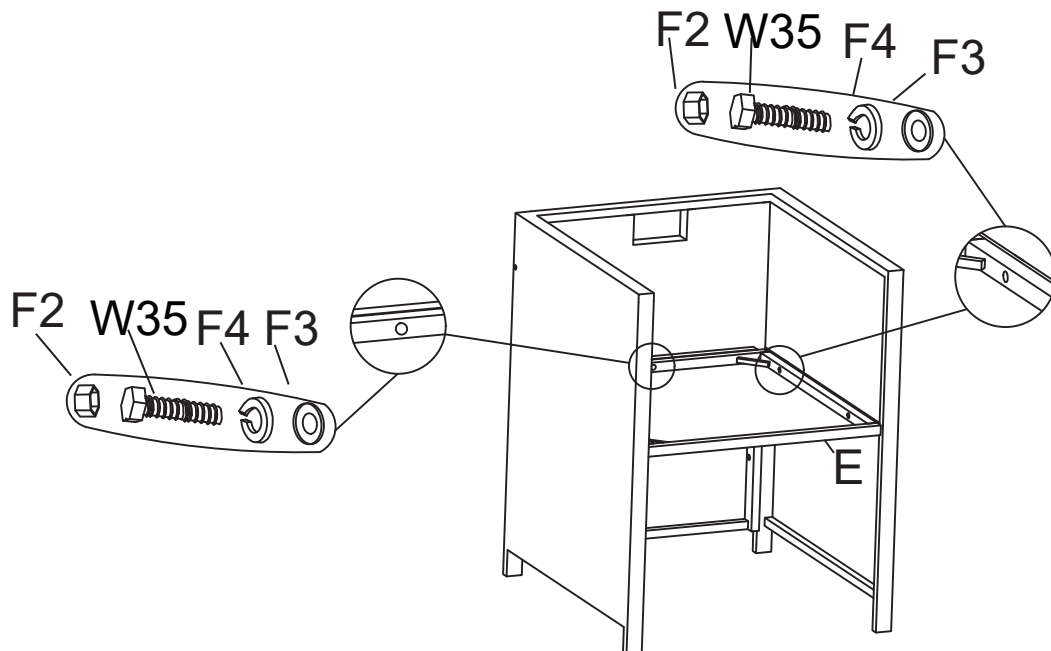

Step Three

Attach Foldable Backrest (B) to the above partly-assembled parts using Plastic Washer (F1), Flat Washers (F3), Spring Washers (F4), Bolts (W35) and Bolt Head Caps (F2).

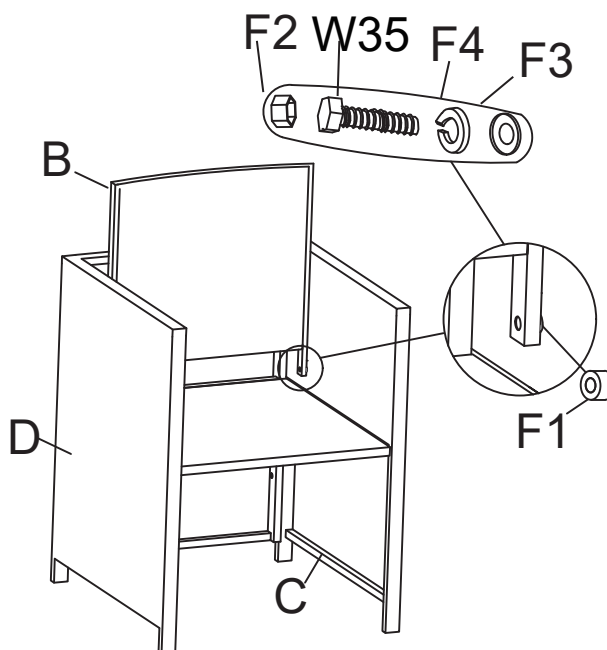

Please note the Plastic Washer (F1) is placed between the Parts (B) and (C or D).

Step Four

Place the Seat Cushion (F) onto the Seat Panel (E).

Your chair is now ready for use.

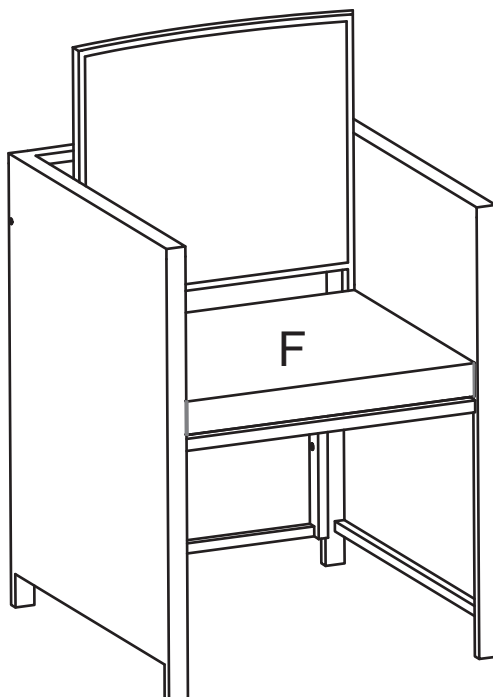

Never tilt the Chair during use.
Ensure the product is always placed firmly
on the ground.

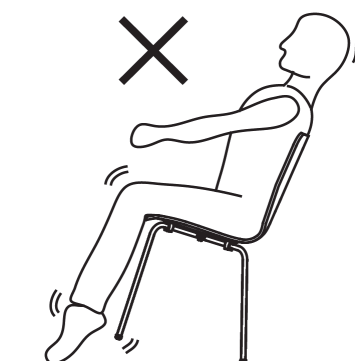

PLEASE KEEP THESE INSTRUCTIONS FOR FUTURE REFERENCE