



AIR PURIFIER

USER MANUAL



*Please refer to the warranty section for terms of your extended guarantee

READING AND STORING THE USER MANUAL



Before using this product, please read through this manual carefully paying particular attention to the safety instructions. Failure to do so may result in personal injury or damage to the product.

Carefully save this instruction manual for future reference. Ensure the user manual is included when passing the product on to any third parties.

IMPORTANT SAFETY INSTRUCTIONS FOR PROPER USE

When using electrical appliances, basic safety precautions should always be followed.

Only use the product as described in this user manual. Any other use is considered improper and may result in damage to property or persons. The manufacturer or vendor cannot be held liable for damages or injury incurred through improper or incorrect use.

- **Read and familiarise yourself with all operating instructions before using this Air purifier.**
- Before using your unit into the mains, visually check that the unit is intact and has not suffered any transit damage.
- Check that the voltage indicated on the data plate corresponds with that of the local network before connecting the appliance to the mains power supply.
- Always use this appliance on a solid, level, non-flammable surface.
- The Air purifier shall not be exposed to dripping or splashing and that no objects filled with liquids, such as vases, shall be placed on the apparatus.
- **DO NOT** immerse the Air purifier or its power cord in water or any other liquids.
- **DO NOT** leave the Air purifier unattended during use.
- **DO NOT** leave the Air purifier unattended whilst connected to a mains power supply.
- Avoid touching any moving parts within the appliance.
- Never insert fingers, pencils or any other objects through the guard.
- **DO NOT** push objects into any openings as damage to the

product and/or electric shock may occur.

- This appliance can be used by children aged from 8 years and above and persons with reduced physical, sensory or mental capabilities or lack of experience and knowledge if they have been given supervision or instruction concerning use of the appliance in a safe way and understand the hazards involved. Children shall not play with the appliance. Cleaning and user maintenance shall not be made by children without supervision.
- Children of less than 3 years should be kept away unless continuously supervised.
- Close supervision is required when using this Air purifier near children.
- Never leave this Air purifier within reach of children.
- It is imperative to unplug from mains supply after the Air purifier has been used, before it is cleaned and whilst being repaired.
- Unplug after each use.
- **DO NOT** operate this appliance if the power cord or plug are damaged. Ensure that the power cord is not stretched or exposed to sharp objects or edges.
- **DO NOT** operate this appliance after a malfunction or after being dropped or damaged in any way.
- **DO NOT** allow the mains cable to hang over sharp edges or come in contact with hot surfaces.
- **DO NOT** run the mains cable under carpets, rugs, etc.
- This product is intended for household use only and should not be used for industrial purposes.
- Never connect the appliance to an electrical outlet using an extension lead. If an outlet is not available, one should be installed by a qualified electrician.
- Never use the mains plug or external timer as a means of switching the Air purifier on or off. Use the ON/OFF button located on the control panel.
- Always place the unit on a dry and stable surface.

- The appliance should not be placed in a laundry or wet room.
- **DO NOT** position the Air purifier close to sources of heat and/or ignition such as radiators, heaters, other electronic equipment, etc.
- No naked flame sources, such as lighted candles, should be placed on the Air purifier.
- The appliance must be stored in such a way as to prevent mechanical failure.
- **DO NOT** use any accessories or attachments with this product other than those supplied or recommended by supplier.
- **DO NOT** use this product for anything other than its intended use.

Explanation of Symbols

The following warning symbols or words are used in this instruction manual:



Products labelled with UK Conformity Assessment identifies products conforming to UK statutory requirements.



Products labelled with this symbol conform to applicable provisions of the European Economic Area.

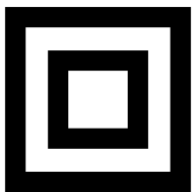

This Class 2 symbol indicates that the product is electrically double insulated and does not require an earth connection.



This symbol provides useful additional information on the use of this product.



This symbol identifies that the supply uses an alternating current mains supply.

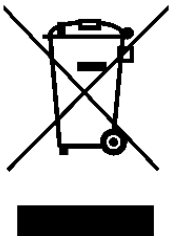

You should now recycle your waste electrical goods and in doing so help the environment. This symbol means waste electrical products at the end of their useful life should not be disposed of with normal household waste. Please ensure it is taken to a suitable facility for disposal. Check with your Local Authority or retailer for recycling advice or visit www.recycle-more.co.uk enter your postcode to find out your nearest recycling site.

Description of Parts

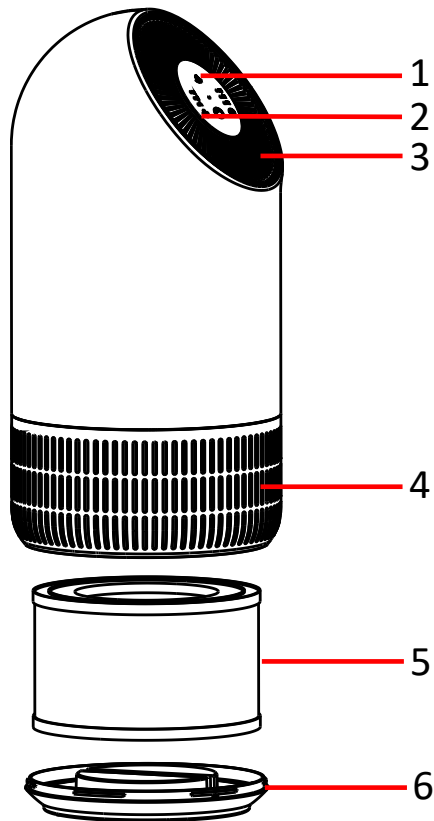

1. Control Panel
2. Night Light
3. Air Outlet
4. Air Inlet
5. Filter
6. Base

Description of Parts – Control Panel

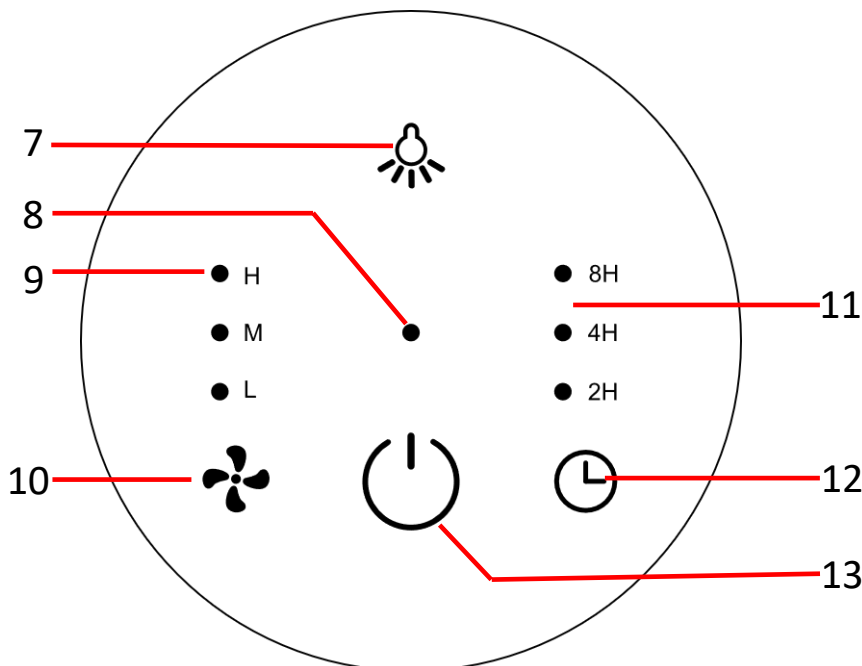

7. Night Light Button
8. Power Indicator
9. Fan Speed Indicator(s)
10. Fan Speed Button
11. Timer Indicator(s)
12. Timer Button
13. Power Button

Before the First Use of Your Air purifier

- Remove all packing materials and discard responsibly.
- Ensure all parts are present see **Description of Parts** above.
- Make sure the appliance is unplugged before removing or installing the filter.
- Wipe the dust off the filter regularly, do not wash.
- Only use the filter specifically designed for this product.
- Ensure the packaging is removed from the filter before first use – see below:

Note Regarding the Filter

1. Turn the unit upside down and rotate the **Base** (6) anticlockwise such that the arrow on the base aligns with the “OPEN” mark and remove.

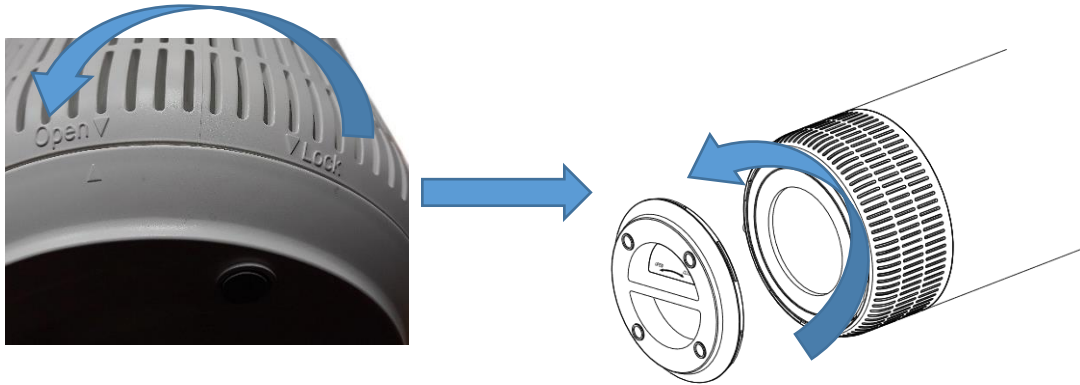

2. Remove the **Filter** (5) from the appliance.

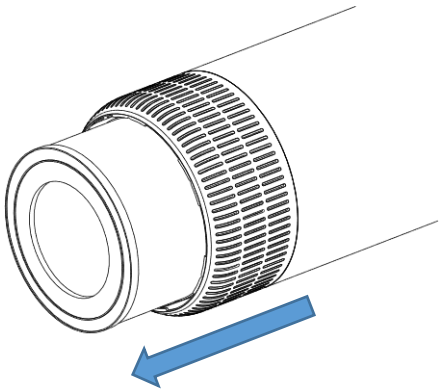

3. Remove the packaging from around the **Filter** (5) before use and discard responsibly.

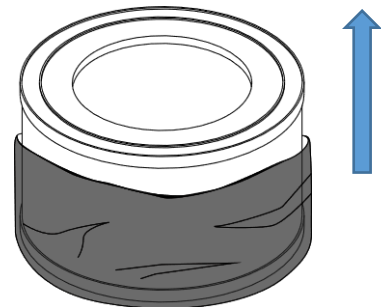

4. Replace the **Filter** (5) into the unit, make sure it is all the way in.

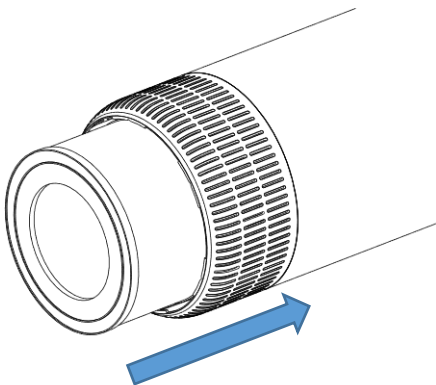

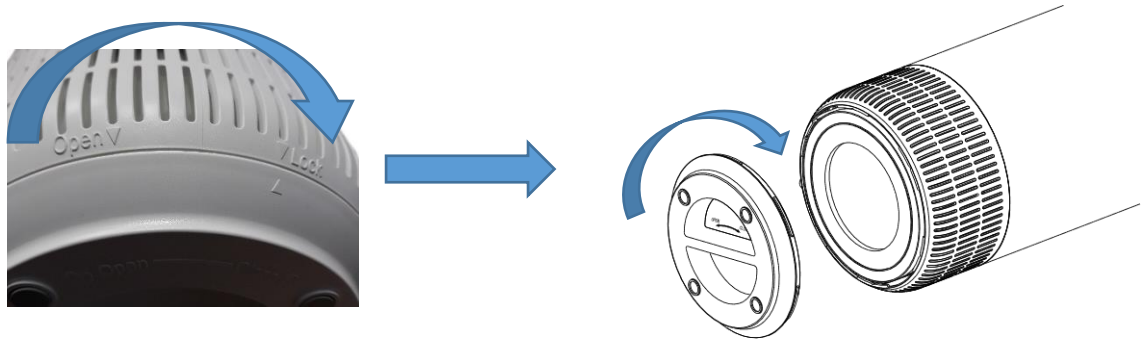

5. Place the **Base (6)** back on, such that the arrow on the base lines up with the 'OPEN' mark on the lower edge then rotate clockwise in the direction marked "CLOSE" to lock the **Base (6)** in position.

Using your Air purifier

Before use, ensure that the unit is placed on a firm, level surface in an area with at least 30cm of free space on all sides to allow for good air circulation.

1. Insert the Mains plug into the nearest socket.
2. The appliance will beep once to confirm power up in standby.

Note: The appliance will beep once for every action.

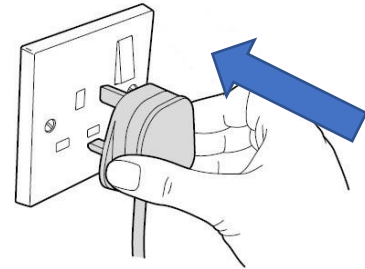

Power Button (13)

1. Touch the **Power Button (13)** to power up the unit, it will beep once, the **Power Indicator (8)** and the **Fan Speed Indicator (L) (9)** will also light.
2. Touch the **Power Button (13)** again to turn the unit off.

Note: The appliance will 'remember' the last setting after being turned off provided the plug has not been removed from the power socket.

Fan Speed Control (10)

Touch the **Fan Speed Button (10)** to adjust the fan speed, select from Low (L), Medium (M) or High (H) speed, the corresponding **Fan Speed Indicator (9)** will light.

Timer Control (12)



1. With the unit powered up, touch the **Timer Button (12)** to select how long the fan will be on for until it switches off.
2. Select from 2, 4 or 8 Hours, the corresponding **Timer Indicator (11)** will light. The unit will begin to count down, when the time is up, the unit will switch off and all indicators on the **Control Panel (1)** will be off.
3. To cancel the Timer function, touch **Timer Button (12)** until no timer indicator is lit.

Note: The Timer function cannot operate in standby mode.

Night Light Button (7)

Touch **Night Light Button (7)** to set the light level between soft and normal mode.

Replacing filter

- Once the appliance has timed that the filter is due for replacement, the **Power Button (13)**  will flash red. Replace the filter by following '**Note Regarding the Filter**' section above.
- After installing a new filter, touch the **Power Button (13)**  for 7sec to reset the filter timer.
- Only use the original type of filter, do not use any other style of filter. The use of any other of filter not recommended by Daewoo may impair the performance of the product and may invalidate your warranty.
- The filter is not washable.
- The filter can be sterilized by placing in sunlight.

Filter Information

Replacement filters are available by telephoning 0161 831 5248 (9.00am-5.00pm Monday-Thursday, 8.00am – 4.00pm Friday) or contacting us via the website: www.esgltd.com quoting COL1524FILTER.

Cleaning and Maintenance

- Always disconnect the Air Purifier from the mains supply before cleaning.
- Do not immerse the appliance into water or any liquid.
- Do not use abrasive, corrosive, or flammable cleaners such as bleach or alcohol, to clean any part of the appliance.
- Do not use a vacuum cleaner to clean the filter or wash it.
- If you do not intend to use the Air Purifier for a long period, store the appliance in a cool and dry environment.

Technical Specification

Model Number	COL1524
Rated Voltage	220-240V~ 50/60Hz
Power	35W
Protection Class	II

Non-Rewireable Mains Plug

If your appliance is supplied with a non-rewireable plug fitted to the mains lead and should the fuse needed replacing, you must use an ASTA approved one (conforming to BS 1362 of the same rating). Never use a plug with the fuse cover missing. If in doubt, consult a qualified electrician.

If you need to remove the plug -**DISCONNECT FROM THE MAINS**- and then cut it off the mains lead and immediately dispose of it safely. Never attempt to reuse the plug or insert it into a socket outlet as there is a danger of electric shock.

Troubleshooting Guide

<i>Problem</i>	<i>Possible Cause</i>	<i>Possible Solution</i>
The unit does not power up	No power.	Ensure the mains plug is in the socket and it is switched on.
	Is the Power Button flashing red?	Renew the filter
	Fuse blown in the mains plug	Check by substitution
Unit not performing well	Fan Speed too low	Increase fan speed
	Filter is dirty	Replace the Filter
	Air inlet blocked	Clean Air Inlet
Unit is noisy	The unit is located on an uneven surface	Position the unit on a flat level surface
Unit not producing fresh Air	Air Inlet dirty	Clean Air Inlet
	Filter is dirty	Renew the Filter
The Power Button is still flashing red after changing the filter.	Filter timer has not been reset	Press and hold the Power Button (13) for 7 seconds to reset the filter timer

Disposal of the Packaging

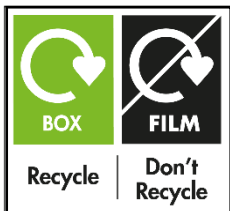

Dispose of paper and cardboard in appropriate paper recycling facilities.
 Dispose of plastics in the appropriate plastics collection service.
 Dispose of non-recyclable plastics in the appropriate plastics collection service.

Disposal of the Product

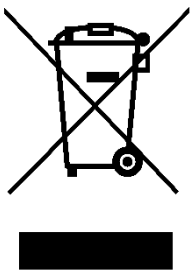

You should now recycle your waste electrical goods and in doing so help the environment. This symbol means waste electrical products at the end of their useful life should not be disposed of with normal household waste. Please ensure it is taken to a suitable facility for disposal. Check with your Local Authority or retailer for recycling advice or visit www.recycle-more.co.uk enter your postcode to find out your nearest recycling site

Customer Support

Should you require any product information, replacement parts or accessories, please contact our customer care team at help@daewooelectricals.com or call 0161 831 7879.

- *Replacement parts and accessories are guaranteed for 1 year from the date of purchase.*
- *It is important to note that your warranty becomes invalid should non Daewoo parts or accessories be used with this appliance*

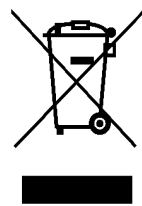
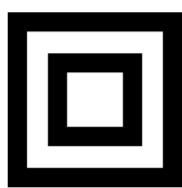
**UK
CA**



DAEWOO®

WARRANTY

Thank you for purchasing your Daewoo product.

As part of our commitment to quality, we are offering you an extra 2 years warranty in addition to your 1 year guarantee

Your Daewoo product is guaranteed for 1 year from the date of original purchase, with proof of purchase or receipt. If any defect should occur due to faulty workmanship or material, your faulty product should be returned to the place of purchase, replacement or refund is at the discretion of the retailer.

The guarantee is subject to the following provisions:

- The product must be correctly installed and operated in accordance with the requirements contained in the instruction manual.
- The product must be used solely for domestic purposes.
- It does not cover general wear and tear, damage, misuse or any consumable parts.
- The guarantee will be rendered invalid if the product is re-sold or has been damaged through inexpert repair.
- The guarantee is only valid within the UK and Eire.

Your standard 1 year guarantee will only be extended to the maximum available for your individual product upon registration. (Note: products must be registered individually and covers the main body and housing). If you do not register your product within 28 days of the original purchase date, your product will only be guaranteed for 1 year.

To validate your extended 2 year warranty* please register your purchase online within 28 days of the original purchase date by registering at:

<https://help.daewooelectricals.com>

or

Contact Us ([daewooelectricals.com](https://www.daewooelectricals.com))

*Your extended warranty is only valid with proof of purchase receipt and subject to the conditions outlined above.

Daewoo is a registered trademark.
Produced and imported under licence by
Eurosonic Group Limited
Brightgate House
1 Brightgate Way
Manchester M32 0TB UK
EU Rep: EuroSonic Magppie (ESM) Ltd. Ireland D05 X006
www.esgltd.com