

0628AXGZ0303NDNW-V1
 28MM LOG CABIN, APEX GAZEBO, 3M X 3M, NO DOOR, NO WINDOWS.



x2 All buildings should be erected by two adults



Winter = High Moisture = Expansion
 Summer = Low Moisture = Contraction



2mm Drill bit

For ease of assembly, you **MUST** pilot drill all screw holes and ensure all screw heads are countersunk.



CAUTION
 Every effort has been made during the manufacturing process to eliminate the prospect of splinters on rough surfaces of the timber. You are strongly advised to wear gloves when working with or handling rough sawn timber.



For ease of assembly use a rubber mallet to fit the log boards. Do NOT use a heavy hammer.



Ensure to measure and check before cutting boards.

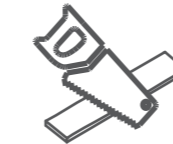

It is advisable to use a hand saw when cutting roof and floor boards.



To ensure log boards are even, use a spirit level to check each layer has been installed correctly.

Screws & Nails



Measure overall length

Bolts



Measure under the head

To identify the fixings required for each step use a measuring tape.

BEFORE YOU START PLEASE READ INSTRUCTIONS CAREFULLY

- Check the pack and make sure you have all the items listed in the parts list provided.
- When you are ready to start, make sure you have the right tools at hand (not supplied - see the equipment list on next page).
- Ensure you have enough time to build the product to ensure the building is water tight.

LOCATION FOR YOUR GARDEN BUILDING

A minimum of 600mm should be left around the perimeter of your garden building to allow access for maintenance, annual treatment and to allow air flow around the building.

Where possible you should avoid placing your garden building underneath large trees to prevent the tree causing damage to the building.

TIMBER

As with all natural materials, timber can be affected during various weather conditions. For the duration of heavy or extended periods of rain, swelling of the wood panels may occur. Warping of the wood may also occur during excessive dry spells due to an interior moisture loss. Unfortunately, these processes cannot be avoided but can be helped. It is suggested that the outdoor building is sprayed with water during extended periods of warm sunshine and sheltered as much as possible during rain or snow.

Once your garden building has been installed it will need to be treated within 14 days (weather permitting) and annually to prevent the timber from deteriorating and to waterproof it. This is required to maintain the anti-rot guarantee.

Log Cabins/Insulated Garden Rooms - Are supplied untreated and require a preservative and waterproofing treatment.

BUILDING A BASE

When thinking about where the building and where the base is going to be constructed: Ensure that there will be access to all sides for maintenance work and annual treatment.

Ensure the base is level and is built on firm ground, to prevent distortion. Refer to diagrams for the base dimensions, The base should be slightly smaller than the external measurement of the building, i.e. The cladding should overlap the base, creating a run off for water. It is also recommended that the floor be at least 25mm above the surrounding ground level to avoid flooding.

TYPES OF BASE

- Concrete 75mm laid on top of 75mm hard-core.
- Slabs laid on 50mm of sharp sand.
- Wooden base.

Whilst all products manufactured are made to the highest standards of safety and in the case of children's products independently tested to EN71 level, we cannot accept responsibility for your safety whilst erecting or using this product.

REGISTER FOR YOUR ANTI-ROT GUARANTEE TODAY

PLEASE SCAN HERE:

In all instances for assistance with your product, please contact customer care on :
 01636 821215 or customerservice@merciagp.co.uk

Mercia Garden Products Limited,
 Sutton On Trent,
 Newark,
 Nottinghamshire,
 NG23 6QN



TO DO LIST

- Find a suitable location to build *(see front cover for further information).*
- Build a base *(see front cover for further information).*
- Check the base is flat, level, clear of debris and has 60cm clearance on all sides.
- Check you have the required equipment.
- Check you have all the product items listed *(if you have missing or damaged parts please contact the customer services department, see front cover for contact details).*
- Install the product as per the step by step instructions within this pack.
- Prepare the product ready for treatment.
- Apply a preserving and a waterproofing treatment within 14 days *(weather permitting)* of installation.
- Register for your anti rot guarantee *(scan the QR below).*
- Tidy the build area and dispose of any remaining parts responsibly.
- Maintain your building *(see the manufacturers recommendations at the back of this pack).*

EQUIPMENT LIST

- Hammer
- Mallet
- Flat Head Screwdriver
- Drill
- Drill Bit Set
- Phillips and Slotted Bit Sets
- Tape Measure
- Hand Saw
- Spirit Level
- Ladders/Steps
- Stanley Knife/Cutting Tool
- Sand Paper
- Gloves
- Silicone (For Windows Only)
- Wood Filler (Optional)
- Timber Preservative Treatment
- Timber Water Proofing Treatment
- Treatment Mixing Stick
- Paint Brush/Sprayer/Roller

NEED EXTRA SUPPORT

If you are unsure that your base preparation will be suitable, please contact us on 01636 821215 to discuss this further.

Alternatively, you can visit our website or MGP Logistics Online Portal for some further sheducation.

Website:

<https://www.merciagardenproducts.co.uk/sheducation>

MGP Logistics Online Portal:

<https://www.mgplogistics.co.uk/>

Here you will find plenty of useful information that'll help with most pre-installation and maintenance queries.



ANY QUESTIONS?
CONTACT US ON
01636 821215

NOTES









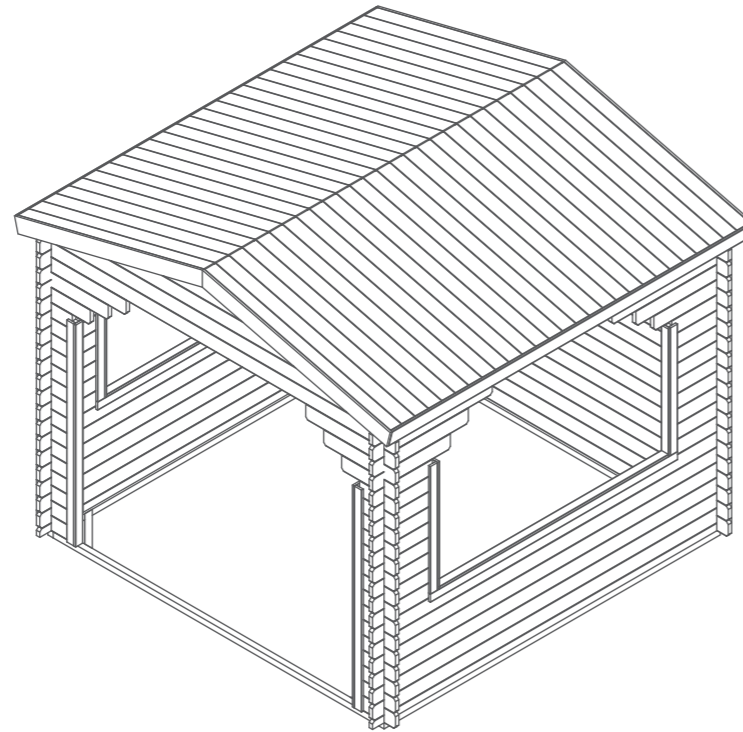

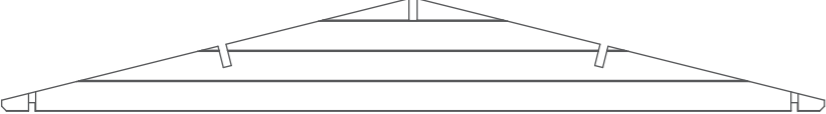





Before assembly
please make sure you have a
suitable base ready to erect your
building























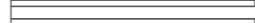





MADE IN GREAT BRITAIN

Overall Dimensions: Width = 3142mm
Depth = 3036mm
Height = 2674mm

Base Dimensions: Width = 2808mm
Depth = 2808mm



-  **1** 
Gable QTY 2
AI-0628AXGZ0303NDNW-G-V1
-  **2** 
Bearer - 44x44x2720mm QTY 2
F4444-2720mm-PT
-  **3** 
Bearer - 44x44x2808mm QTY 2
F4444-2808mm-PT
-  **4** 
Angled bearer - 44x44x440mm QTY 4
F4444-G-440mm-PT (2 x angled cuts, finished length 400mm)
-  **5** 
Starter Board - 28x66x3000mm QTY 2
LB28RT66-A-3000mm
-  **6** 
Log Board - 28x120x3000mm QTY 38
LB28-A-3000mm
-  **7** 
Log Board - 28x120x300mm QTY 30
LB28-B-300mm
-  **8** 
Log Board - 28x120x500mm QTY 36
LB28-B-500mm
-  **9** 
Log Board - 28x120x650mm QTY 4
LB28-B-650mm

-  **10** 
Log Board - 28x120x800mm QTY 4
LB28-B-800mm
-  **11** 
Log Board - 28x120x1000mm QTY 4
LB28-B-1000mm
-  **12** 
Log Board - 28x120x450mm QTY 2
LB28-B-450mm
-  **13** 
Log Board - 28x120x600mm QTY 2
LB28-B-600mm
-  **14** 
Log Board - 28x120x750mm QTY 2
LB28-B-750mm
-  **15** 
Window Cill - 60x60x2064mm QTY 2
AI-0628AXGZ0303NDNW-WC-V1
-  **16** 
Window Frame - 60x60x950mm QTY 4
AI-0628AXGZ0303NDNW-WF-V1
-  **17** 
Door Frame - 60x60x1605mm QTY 2
AI-0628AXGZ0303NDNW-DF-V1
-  **18** 
Purlin - 45x120x3004mm QTY 3
F45120-A-3004mm
-  **19** 
Roof Board - 16x121x1600mm QTY 56
MB16-1600mm
-  **20** 
Eaves Frame - 27x44x3004mm QTY 2
F2744-3004mm
-  **21** 
Window Cill Trim - 16x120x1912mm QTY 2
S1660-1912mm
-  **22** 
Door Frame Trim - 16x120x1605mm QTY 2
S1660-1605mm
-  **23** 
Window Frame Trim - 16x120x922mm QTY 4
S1660-922mm
-  **24** 
Fascia - 16x120x3100mm QTY 2
S16120-3100mm

25 
Fascia - 16x120x1700mm QTY 2
S16120-G-1700mm (1x angled cut)

26 
Storm Brace - 27x44x2000mm QTY 8
F2744-2000mm

27 
Closure Trim - 16x28x2400mm (approx length) QTY 5
S1628-2400mm

28 
Felt

29 
Roof Spacers QTY 5
PI-07-0208 (20x100x2mm)

Pre-assembly

***Please note:**

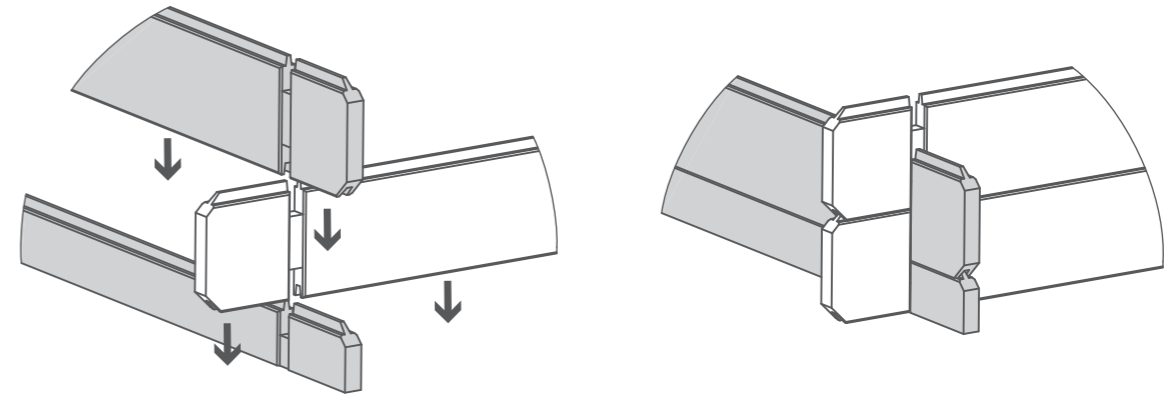

Each board interlocks at either end in a staggered pattern.

Before securing ensure that the boards are fitted properly in their respective tongues and grooves.

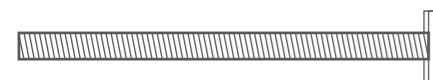
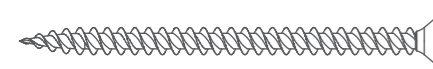
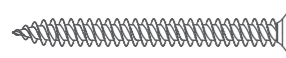

Nail Bag

There may be extra screws present in the nail bag

-  **70mm Bolt Set x 16**
-  **70mm Screw x 76**
-  **40mm Screw x 220**
-  **30mm Screw x 30**
-  **Felt Tacks x 160**

Step 1

- Parts Needed - No. 2 QTY 2**
No. 3 QTY 2
No. 4 QTY 4

Lay the bearers (**No. 2 & 3**) onto a firm and level surface (**free from areas where standing water can collect**) as shown in the illustration.

Fix the bearers together at each corner using 2x70mm screws per corner, ensuring the bearers are flush.

Place the angled bearers (**No. 4**) at each corner as shown, ensuring they are flush and level. Fix the bearers together by screwing through the external bearers into the angled bearer using 2x70mm screws per end, as shown.

Once fully assembled, ensure the bearers are square by measuring from corner to corner as illustrated, making sure the measurements are equal.

If the bearers are not square, unscrew, adjust and re-align accordingly.

24x70mm Screws

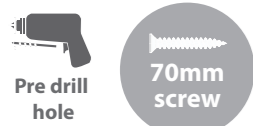

IMPORTANT: Pre-drill before fixing screws.

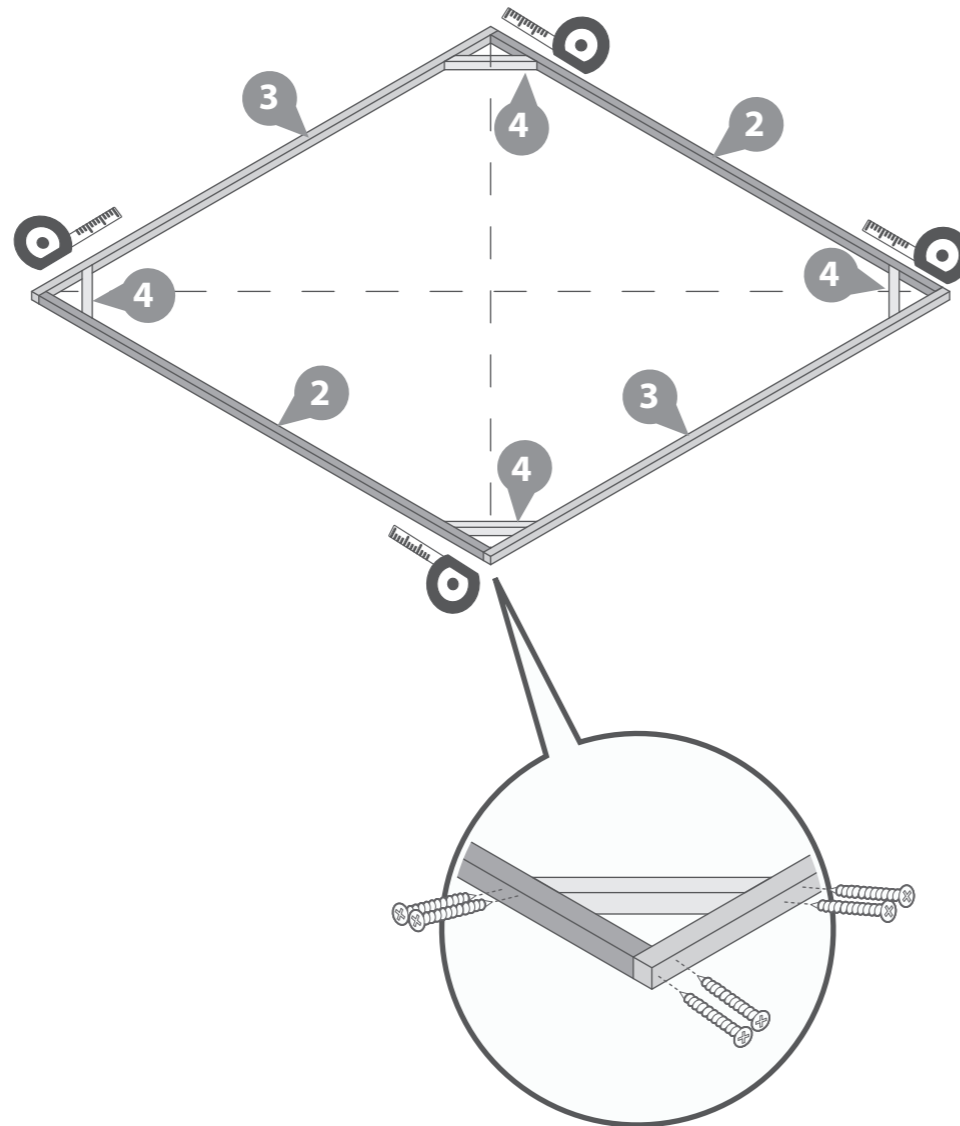

Step 2

- Parts Needed - No. 5 QTY 2**
No. 6 QTY 1
No. 7 QTY 2

Place the starter boards (**No. 5**) onto the assembled base frame and place the first log boards (**No.6 & 7**) in the starter board notches as shown.

Ensure the boards sit square on the base using the same method used in Step 1. Measure corner to corner, making sure the measurements are equal.

Once the boards are square, lift up the log boards (**No. 6 & 7**) and fix the starter boards in place by screwing through the notch into the bearer below as shown in the illustration.

4x70mm Screws

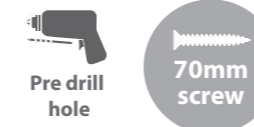

IMPORTANT: Pre-drill before fixing screws.

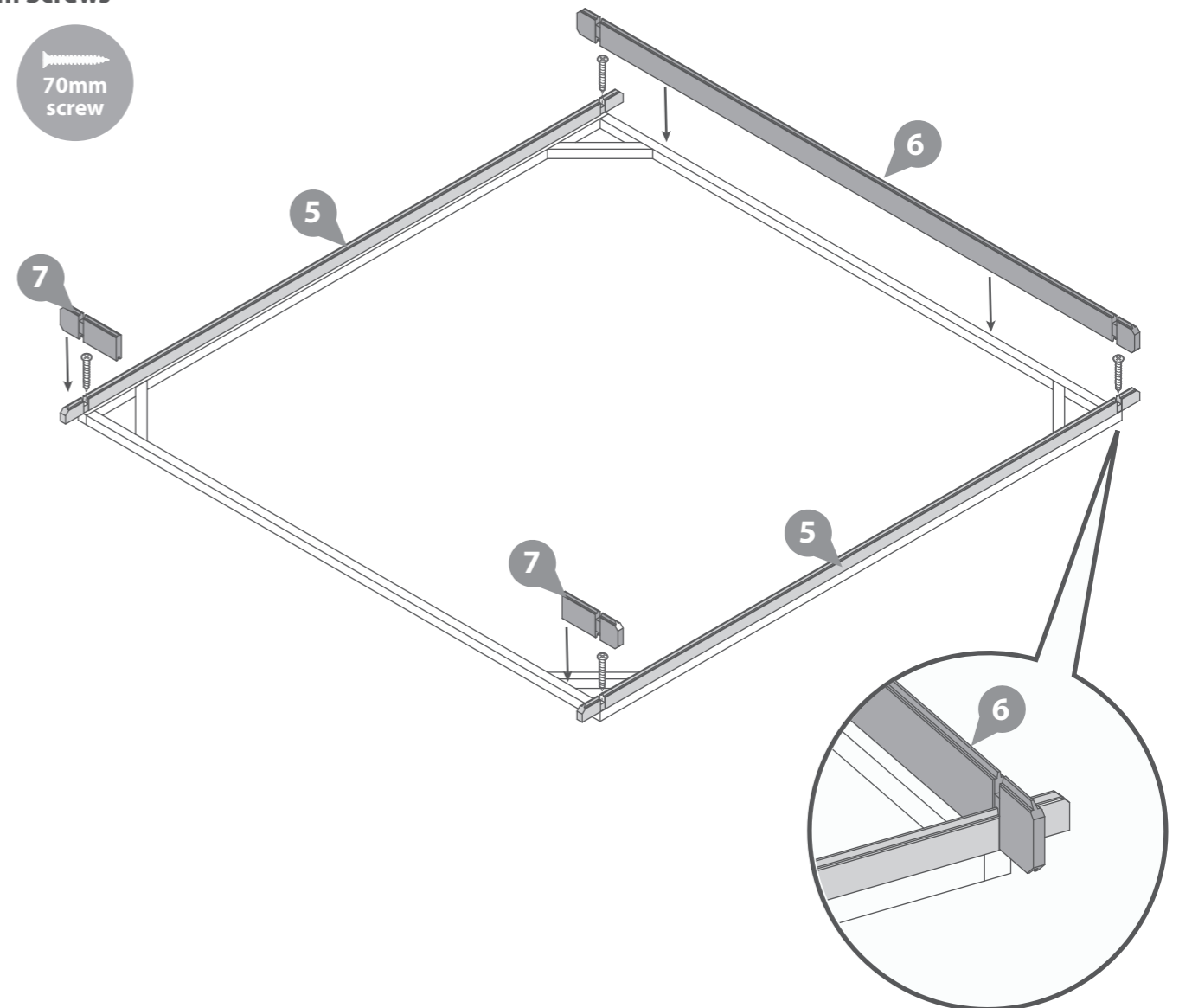
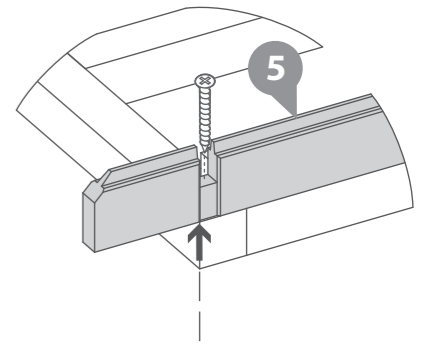

Step 3
Parts needed - No. 6 QTY 18
No. 7 QTY 12

Following the method shown in the illustration, lay the first six boards (No. 6 & 7) on each side.

Start by placing the left and right side boards, interlocking them with the front and back boards. Then place the next front and back boards, interlocking with the left and right boards. Continue this method until you have placed **six boards off of the starter boards on each side**, as shown in the illustration.

This will create your first level.

**Ensure that the boards are level and flush with each other as you lay each one.*

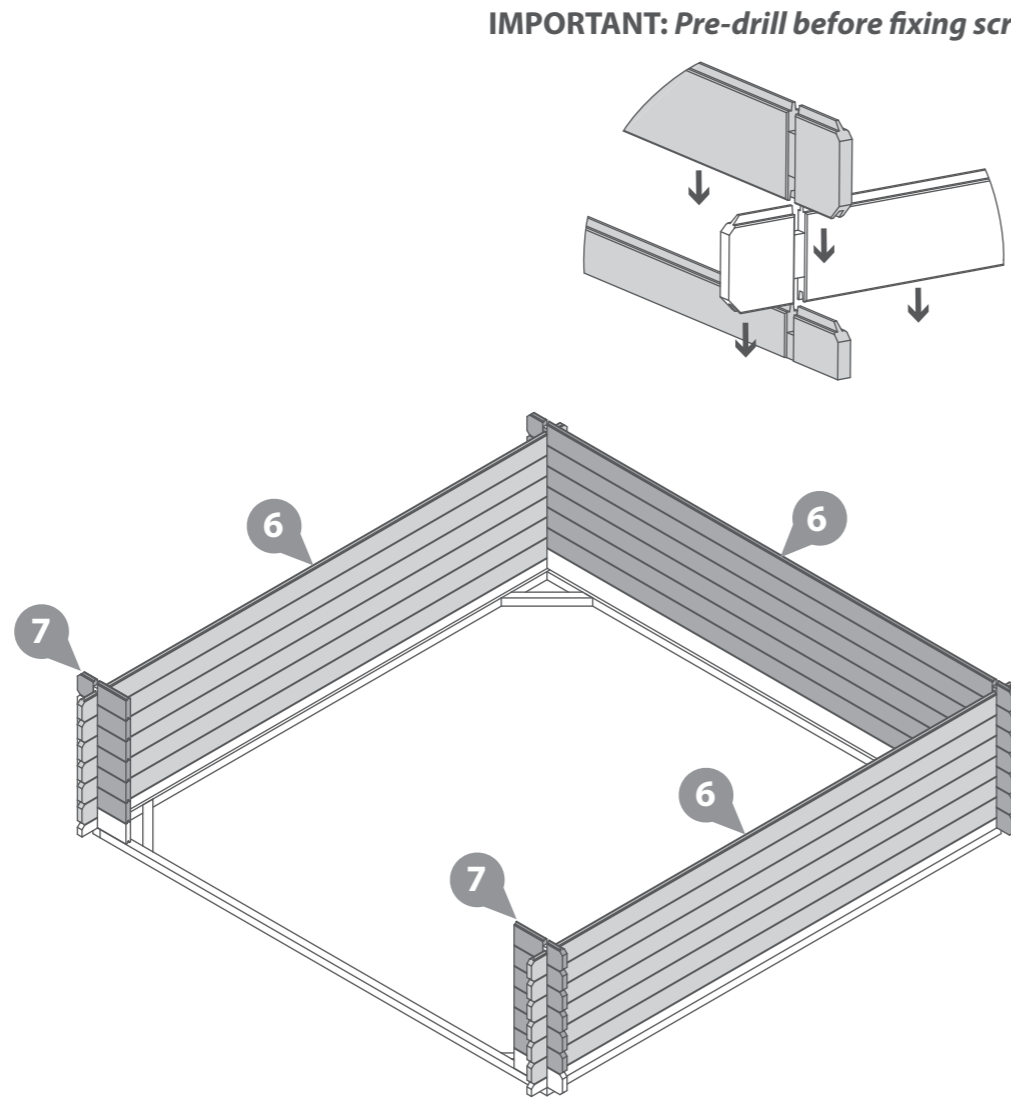

Step 4
Parts needed - No. 6 QTY 6
No. 7 QTY 12
No. 8 QTY 24

Following the same method used in the previous step, lay the next layer of boards (No. 6, 7 & 8) onto the Log cabin to create your second layer, as shown

**Ensure that the boards are level and flush with each other as you lay each one.*

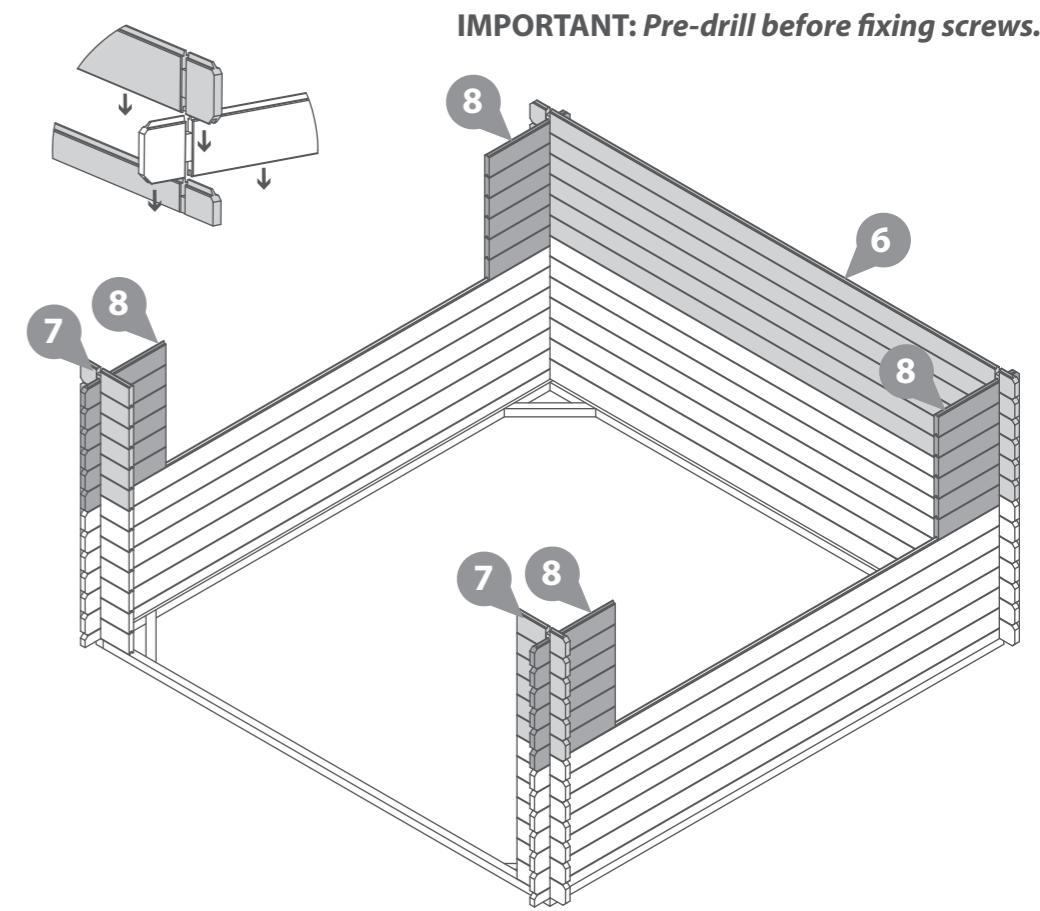
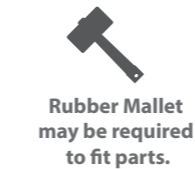

Step 5
Parts needed - No. 15 QTY 2
No. 16 QTY 4

Arrange the Window Cill (No.15) and two Window Frames (No.16) as shown in the illustration, ensuring the framing slots together, is flush and level.

Secure the Window Frames (No.16) to the Window Cill (No.15) by screwing through the framing into the cill behind, using 2x70mm screws per frame, as shown.

Repeat to create two assembled window frames.

8x70mm screws.

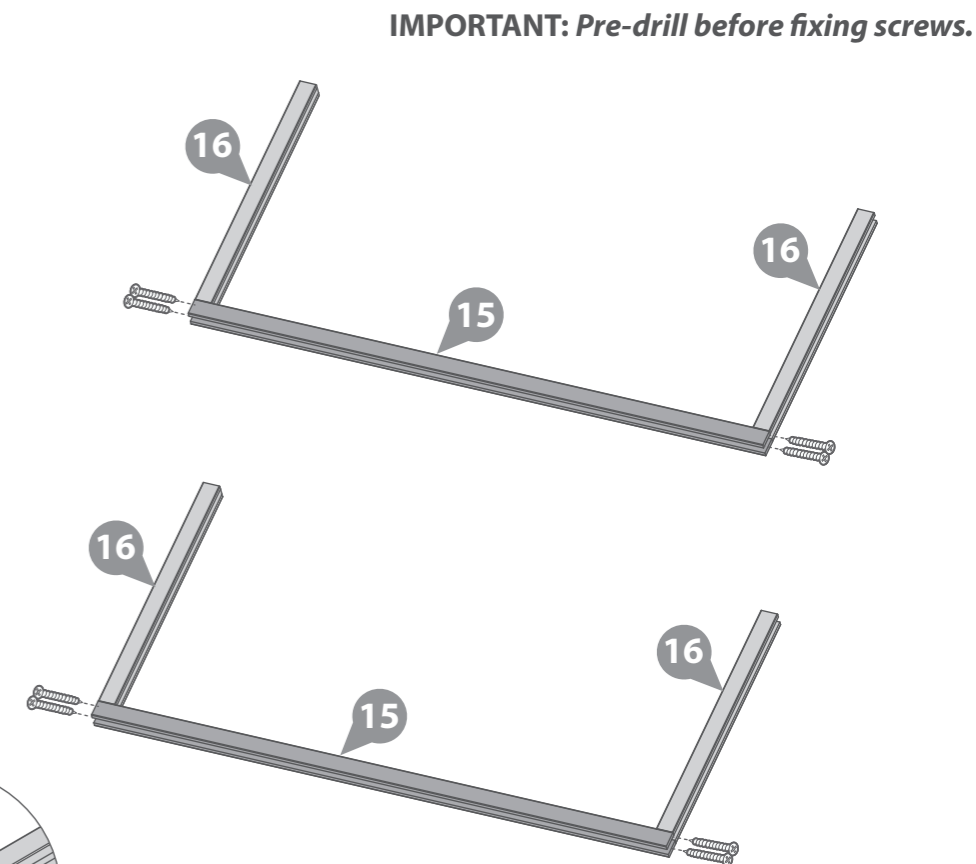
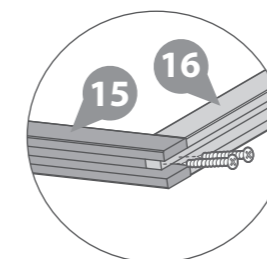

Step 6

- Parts needed - No. 15 QTY 2**
No. 16 QTY 4
No. 17 QTY 2

Locate the assembled Window Frames (**No. 15 & 16**) into the window cut outs on the sides of the log cabin, as shown.

Locate the Door frames (**No. 17**) into place on the front opening of the log cabin, as shown.

Do not fix the frames in place until the roof is secured.

Ensure the frames are flush and level to the log boards.



Rubber Mallet may be required to fit parts.

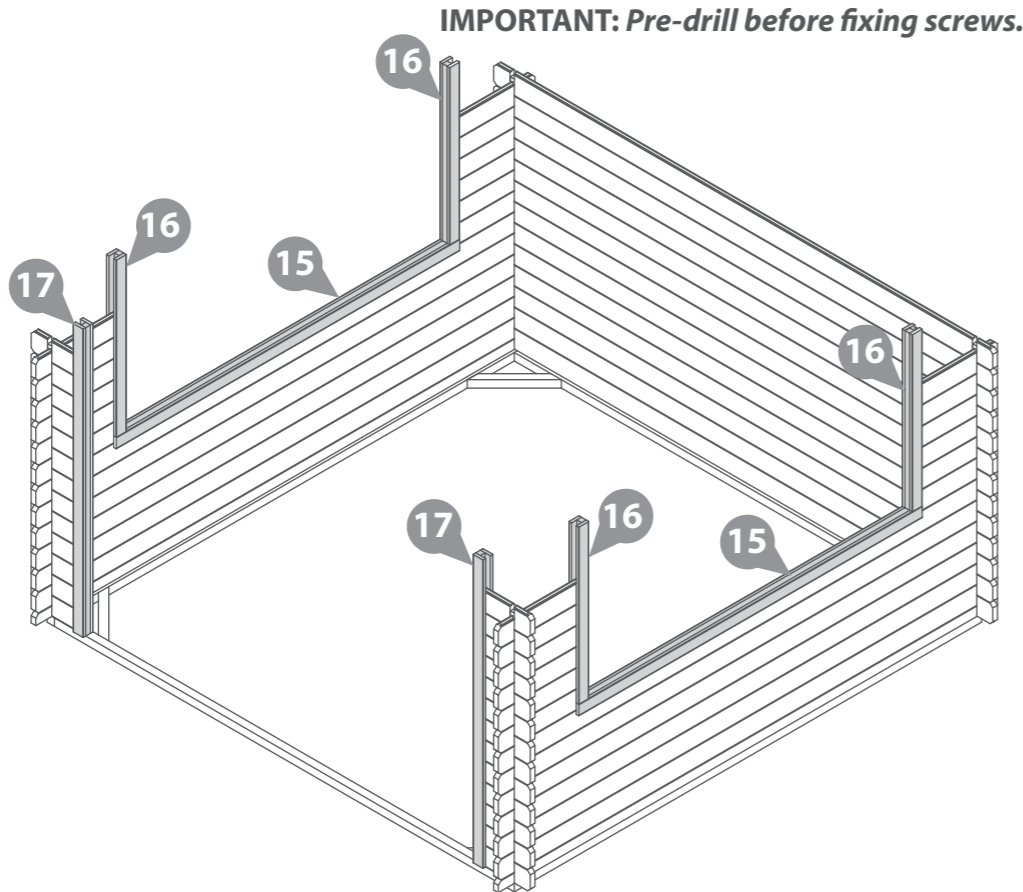

IMPORTANT: Pre-drill before fixing screws.

Step 8

- Parts needed - No. 6 QTY 6**
No. 10 QTY 4
No. 11 QTY 4
No. 13 QTY 2
No. 14 QTY 2

Following the same method used in the previous steps, lay the next layer of boards (**No. 6, 10, 11, 13 & 14**) onto the Log cabin, ensuring to place the correct boards to create a staggered pattern on the sides and front of the log cabin.

***Ensure that the boards are level and flush with each other as you lay each one.**



Rubber Mallet may be required to fit parts.

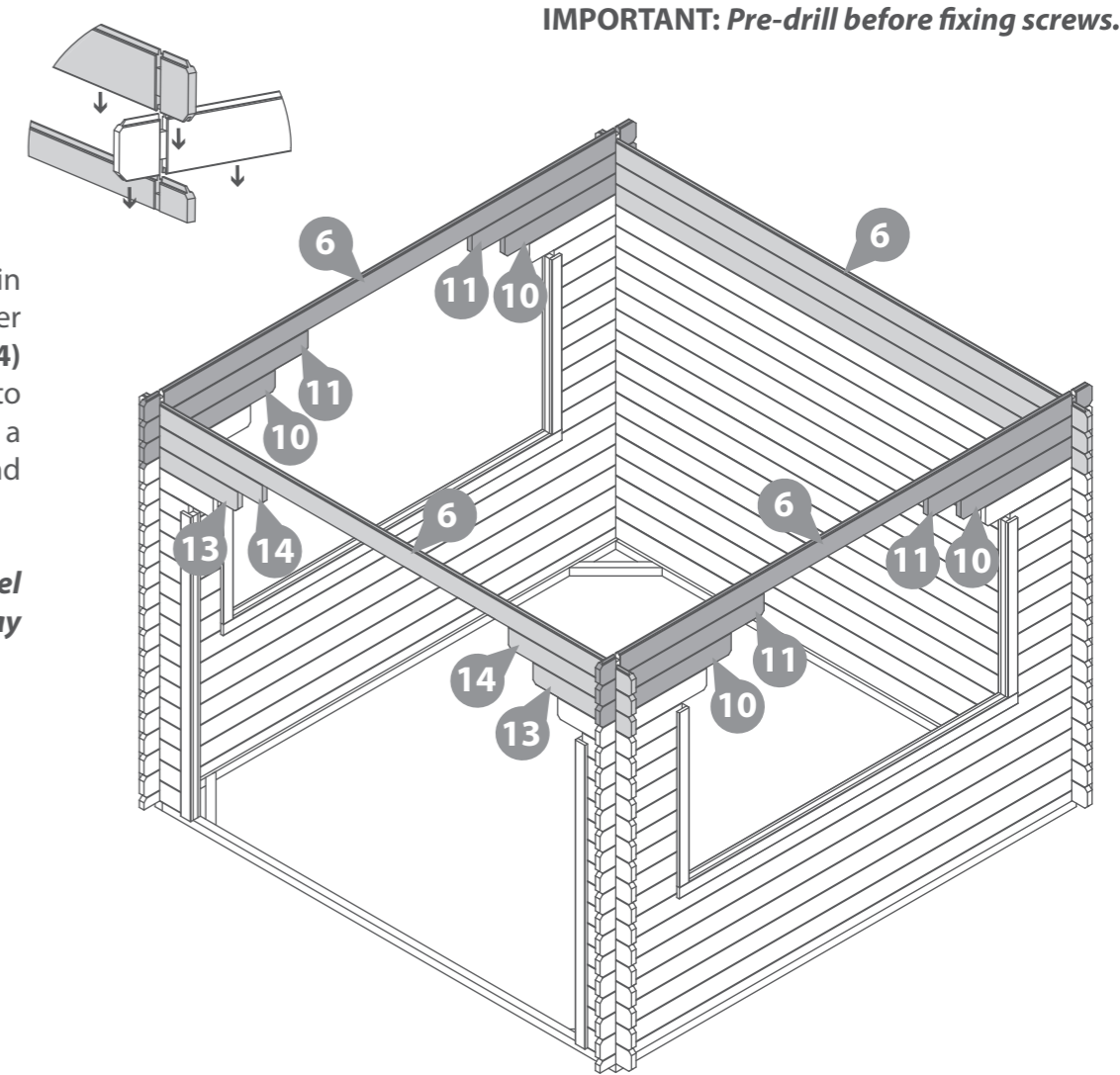

IMPORTANT: Pre-drill before fixing screws.

Step 7

- Parts needed - No. 6 QTY 3**
No. 7 QTY 4
No. 8 QTY 12
No. 9 QTY 4
No. 12 QTY 2

Following the same method used in the previous steps, lay the next layer of boards (**No. 6, 7, 8, 9 & 12**) onto the Log cabin, ensuring to place the correct boards to create a staggered pattern on the sides and front of the log cabin.

***Ensure that the boards are level and flush with each other as you lay each one.**



Rubber Mallet may be required to fit parts.

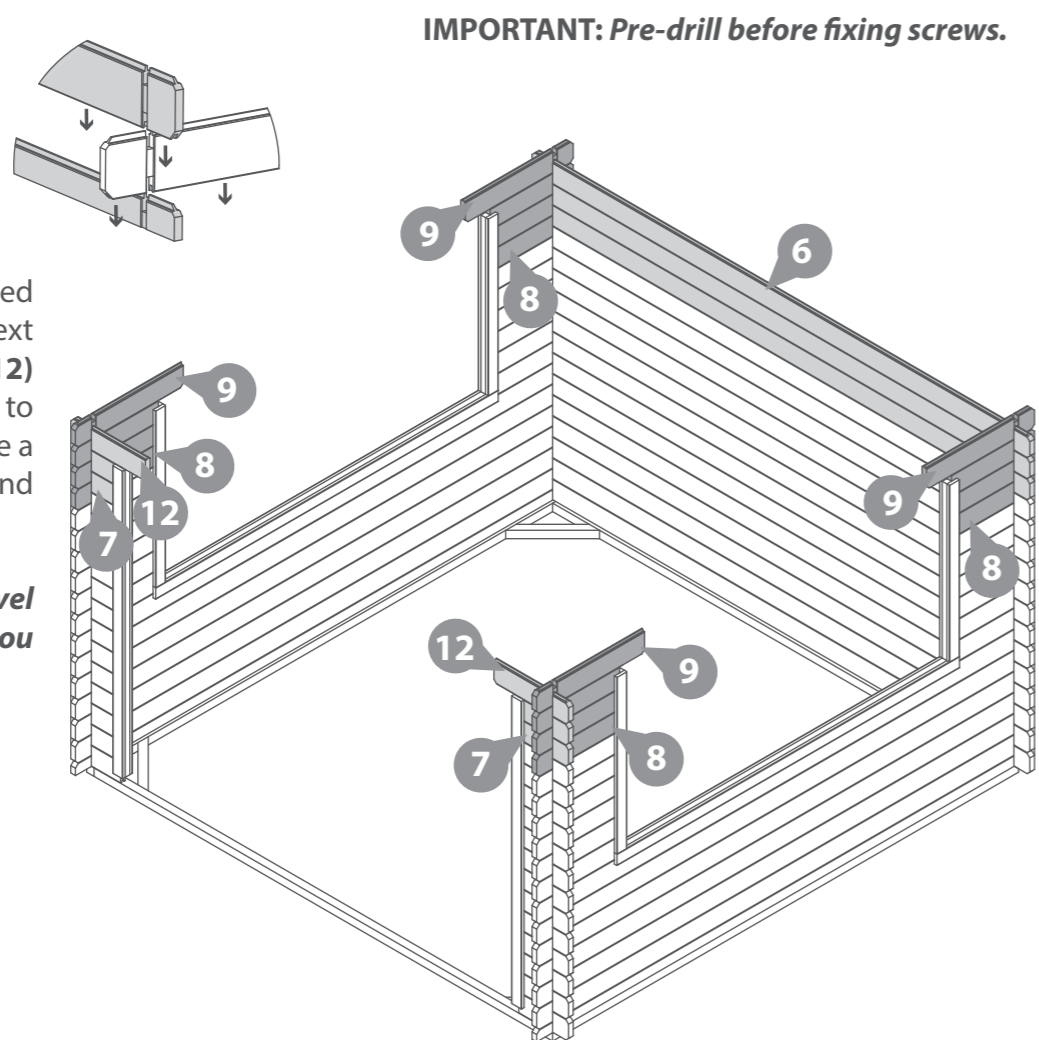

IMPORTANT: Pre-drill before fixing screws.

Step 9
Parts needed - No. 6 QTY 4

Following the same method used in the previous step, lay the last four boards (No. 6) onto the Log cabin.

Once in position, secure the boards down at each corner, ensuring to screw through the notch into the board below using 1x70mm screw per corner.

**Ensure that the boards are level and flush with each other as you lay each one.*

4x70mm screws.

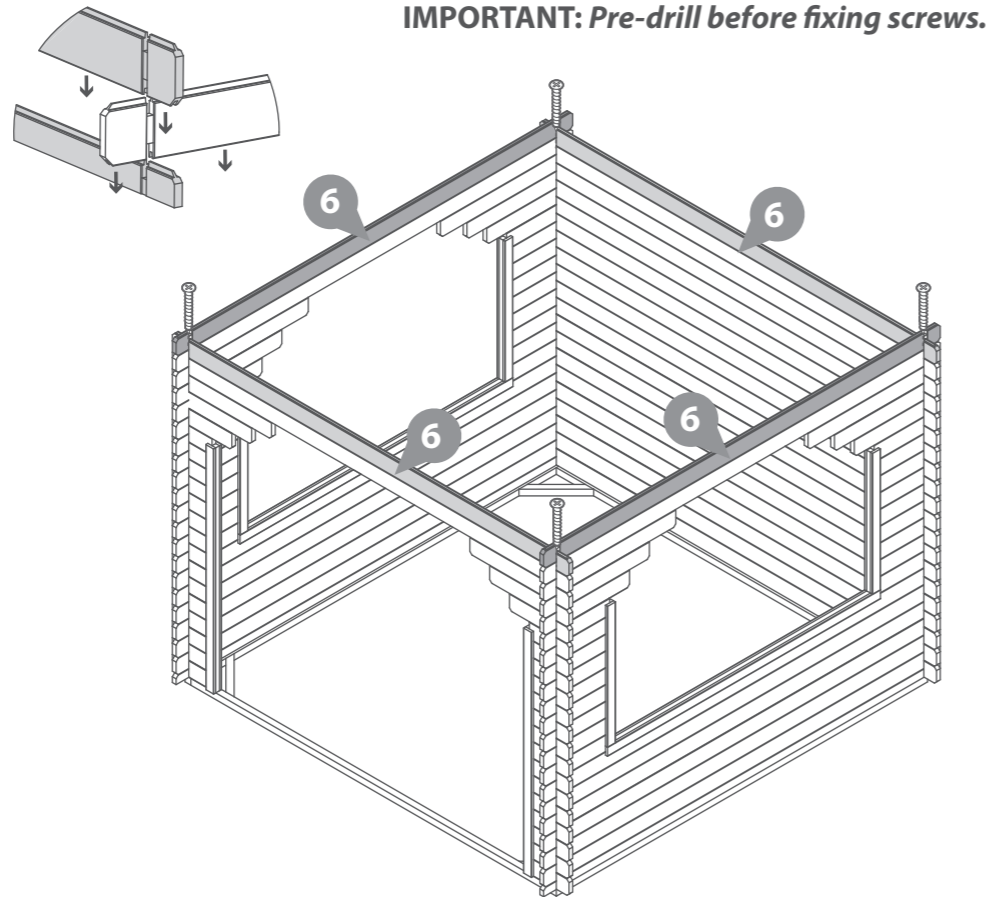
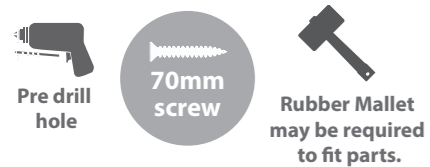

Step 10
Parts needed - No. 1 QTY 2

Place the Gables Tops (No. 1) onto the front and back of the Log cabin.

Fix into position by screwing through the notches into the boards below using 1x70mm screw per corner, as shown.

**Ensure that the boards are level and flush with each other as you lay each one.*

4x70mm screws.

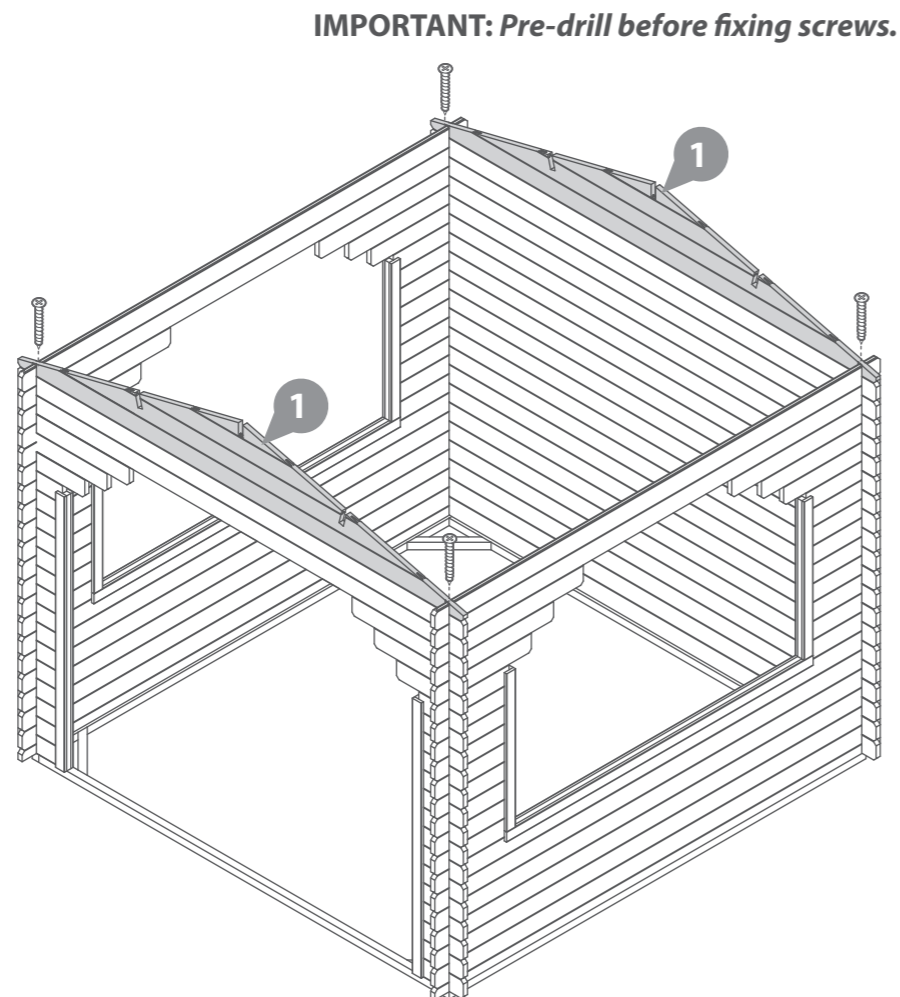
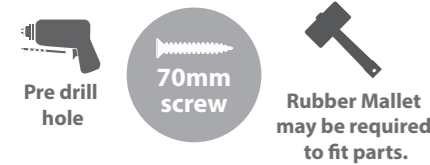

Step 11
Parts needed - No. 18 QTY 3

a Align the Purlins (No. 18) into the cut out slots on each gable, ensuring each purlin interlock with the boards.

b Secure the Purlins (No. 18) at each end by screwing through the purlins at an angle into the boards below, using 2x70mm screw per end.

12x70mm screws.

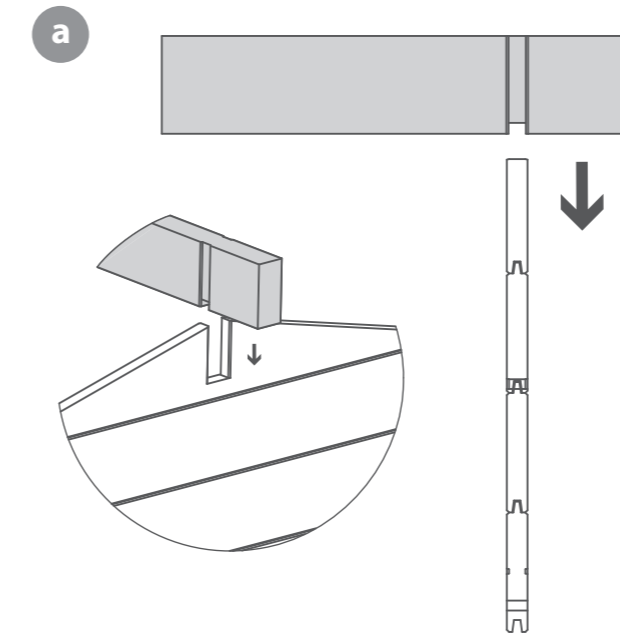
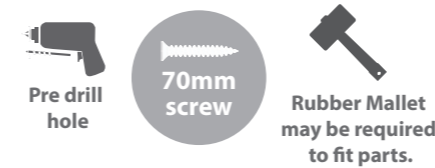

IMPORTANT: Pre-drill before fixing screws.

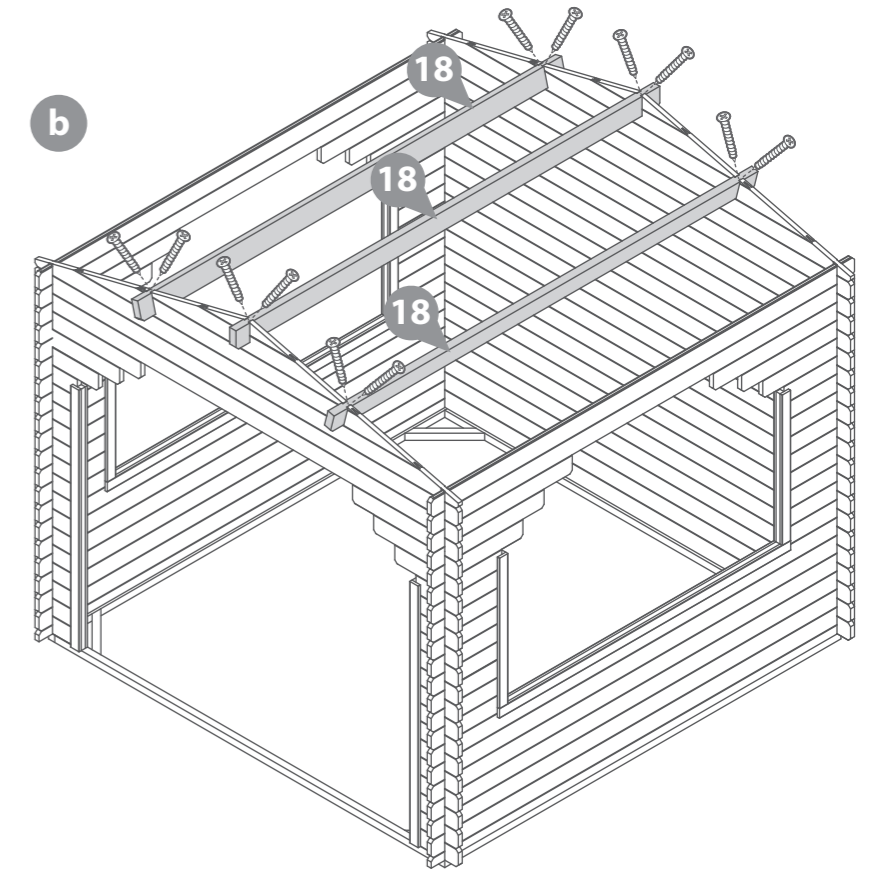

Step 12

Parts needed - No. 19 QTY 56

a Place the first two roof board's (**No.19**) onto the back of the log cabin on each side, making sure the boards are flush to the end of the roof purlin. Once in position fix to each purlin using 3x40mm screws.

Continue adding the roof boards along the roof, fixing each one into position using 3x40mm screws, making sure that each board is interlocked, flush at the bottom & meet at the top of the apex.

Ensure the roof boards are not laid too close together, use the spacers (**No.29**) provided to create a 2mm gap. Adjusting the spacing between the boards allows the wood to swell in damp weather.

You have been issued with 56 roof boards, however you may only need to use 54.

***Ensure the roof boards meet at the top of the apex and leave an overhang at the bottom.**

b The last board on each side will overhang past the end of the purlins: Using a straight edge and a pencil, mark out a line as a guide of where the board will meet the end of the purlin.

Cut along the pencil mark and remove the excess. Place the cut down boards back onto the roof and secure into place using 3x40mm screws per board.

***Please Note:** This image is for illustrative purposes and may differ from your choice in product. Nevertheless the process of cutting and fitting the last roof boards is the same.

160x40mm Screws

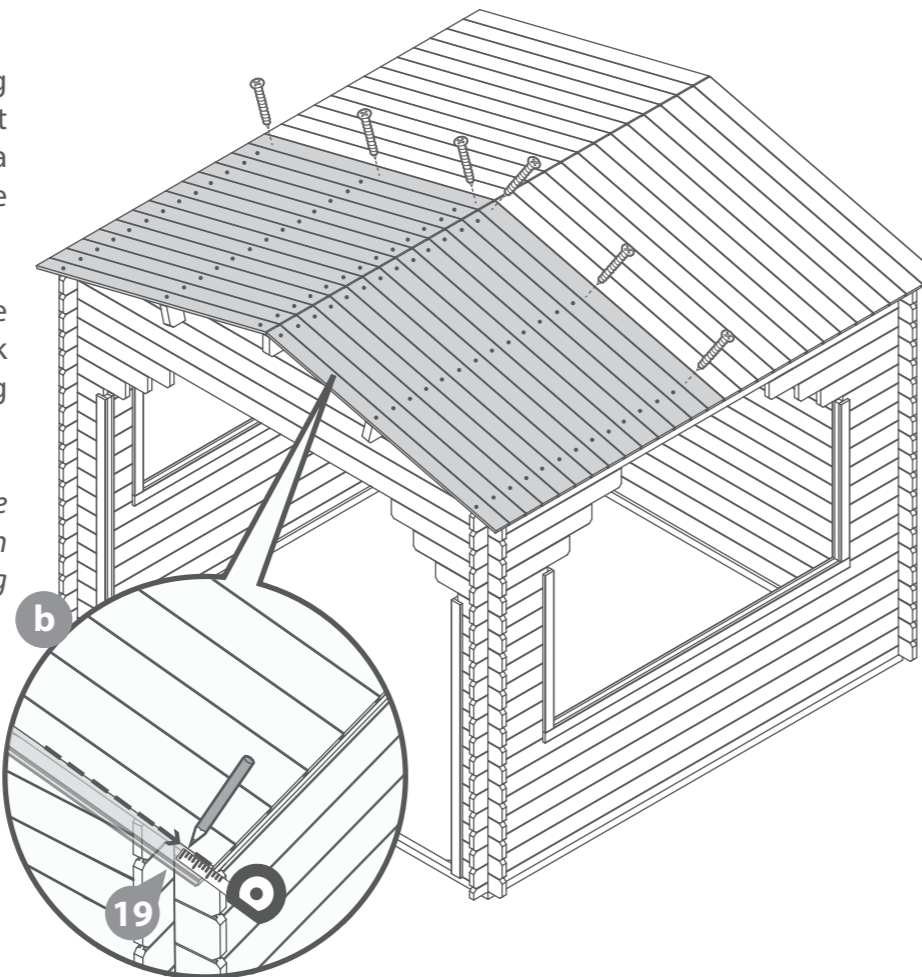
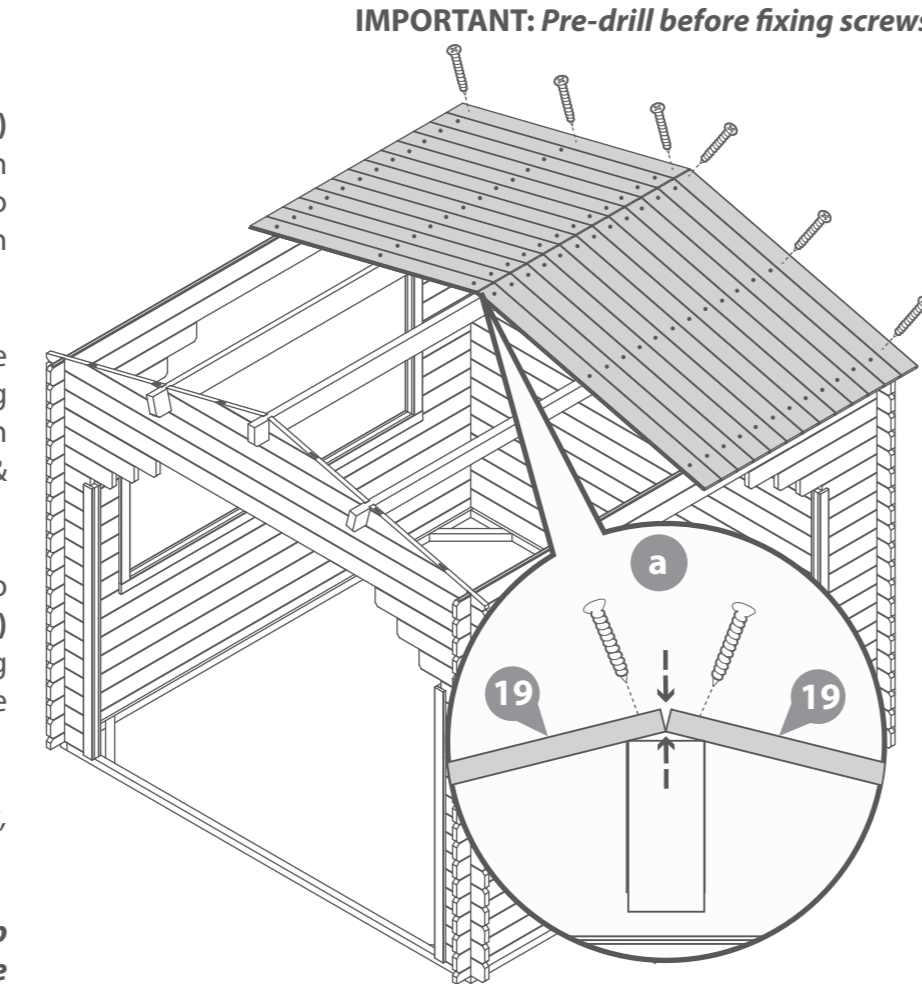

Step 13

Parts needed - No. 20 QTY 2

Ensuring the Roof Boards are flush at the overhanging side and meet at the apex, locate the Eaves Frames (**No. 20**) to the underside of the Roof boards on either side of the log cabin.

Fix the Eaves Frames in place using 9x40mm screws, screwing through the Roof boards into the Eaves frame below. Ensure the ends are flush with the Roof Boards.

18x40mm screws.

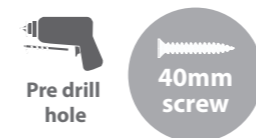

Step 14

Once the roof is secured, re-position the Door Frames (**No.17**) so they are flush to the first overhanging log board, and the gap is at the bottom, as shown.

Ensure the Door and window frames are level and flush with the log boards.

Secure the Door Frames (**No.17**) in place using 4x70mm screws per frame.

Secure the Window Frames (**No.16**) in place using 3x70mm screws per frame.

20x70mm screws.

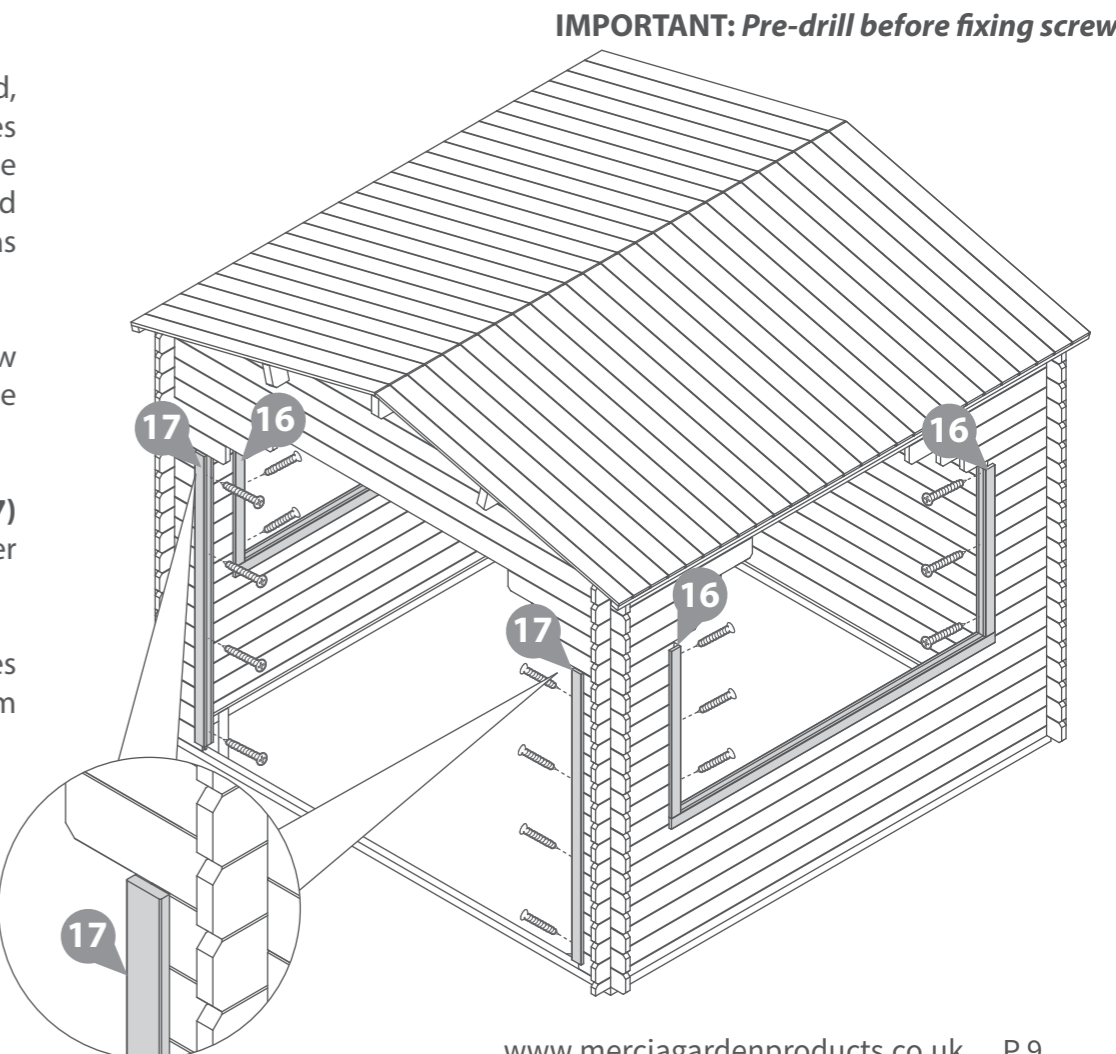
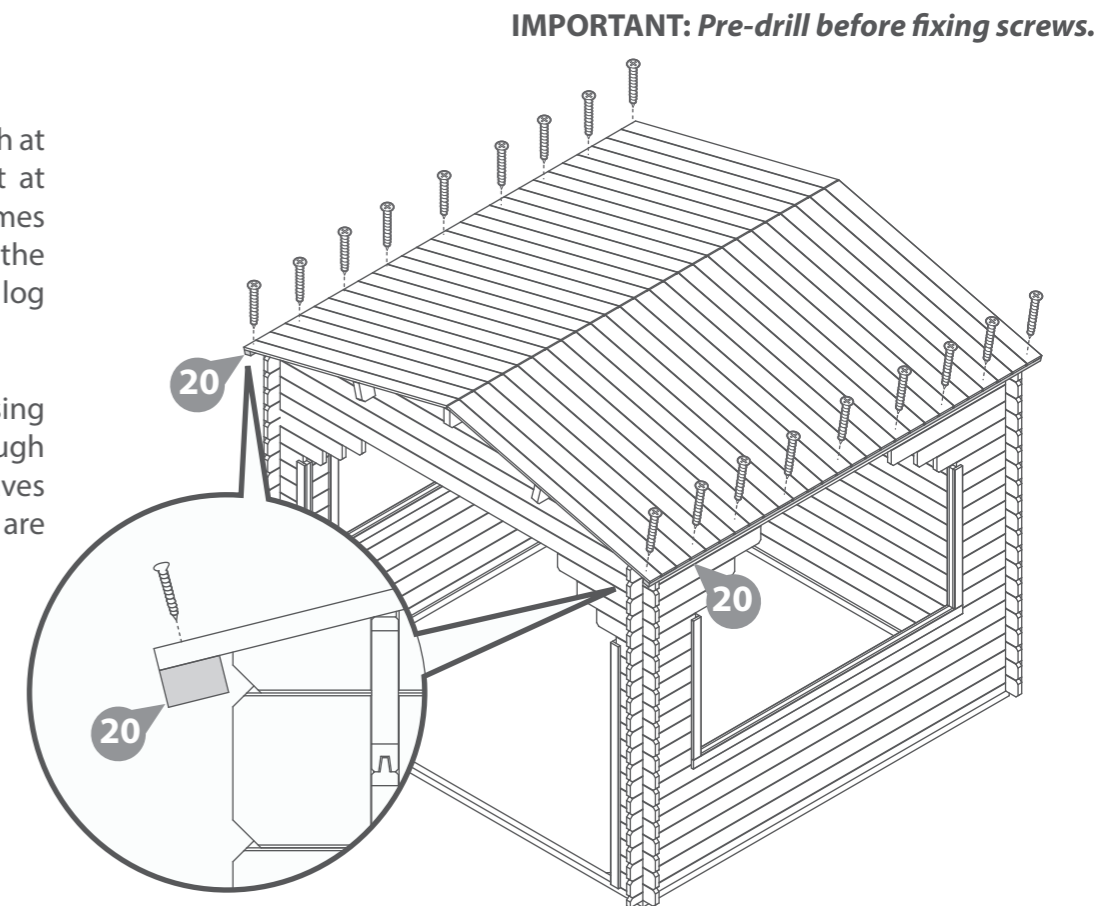
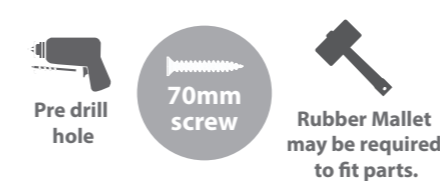

Step 15
Parts needed - No. 27 QTY 5

Inside the building place the closure trim (No. 27) against the boarding and align with the roof as shown in the illustration.

***Measure and cut the closure trims to fit the internal space.**

Once in position fix each trim into place by pre drilling a pilot hole and using 6x30mm screws per trim, equally spacing them along the face of the board.

30x30mm Screws

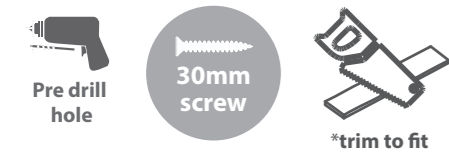

IMPORTANT: Pre-drill before fixing screws.

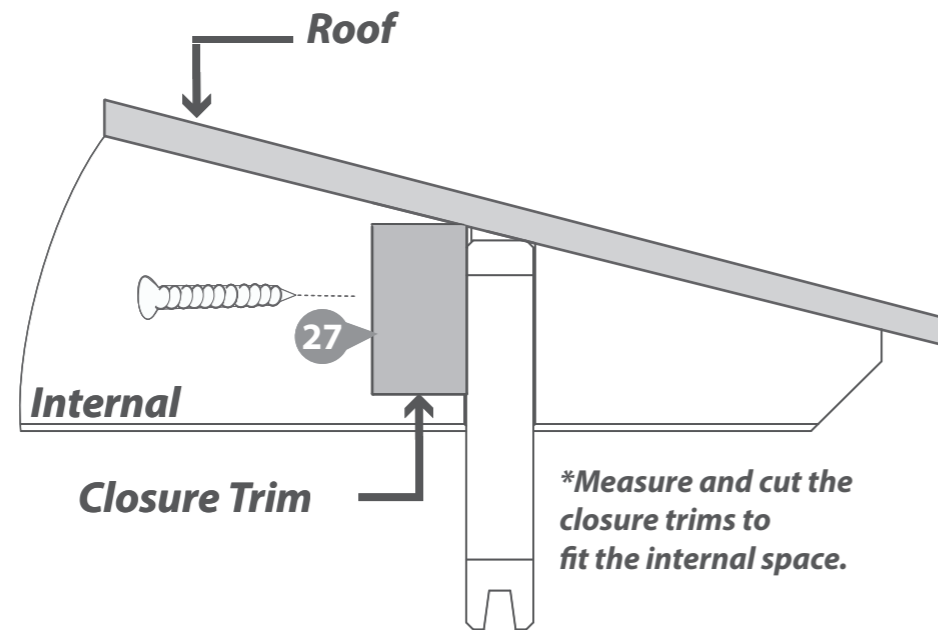

Step 16
Parts needed - No. 28 QTY 1

Cut the felt (No. 28) into four strips measuring: **3200mm (L) x 1000mm (W)**.

Lay the sheets onto the roof in the order shown in the illustration.

***Ensure there is approximately 50mm of overhanging felt each side.**

Once the felt is laid out, fix to the roof using felt tacks at 100mm intervals.

160 x Felt Tacks

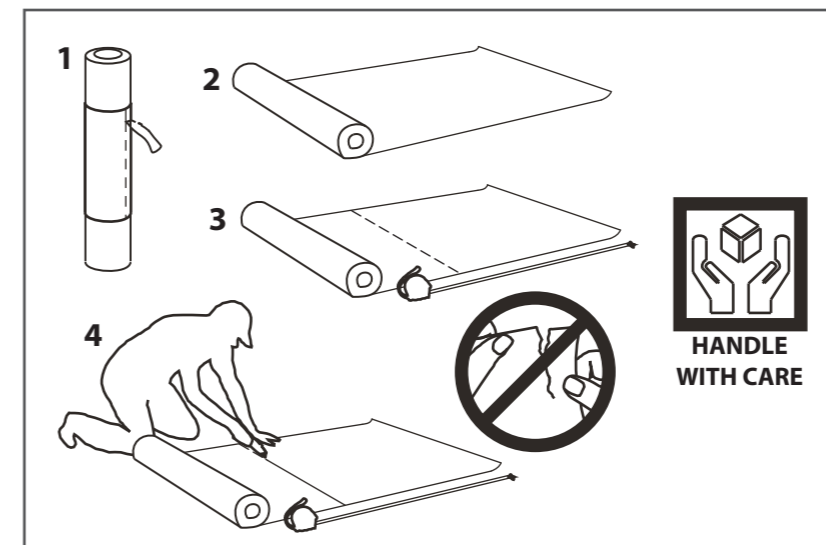
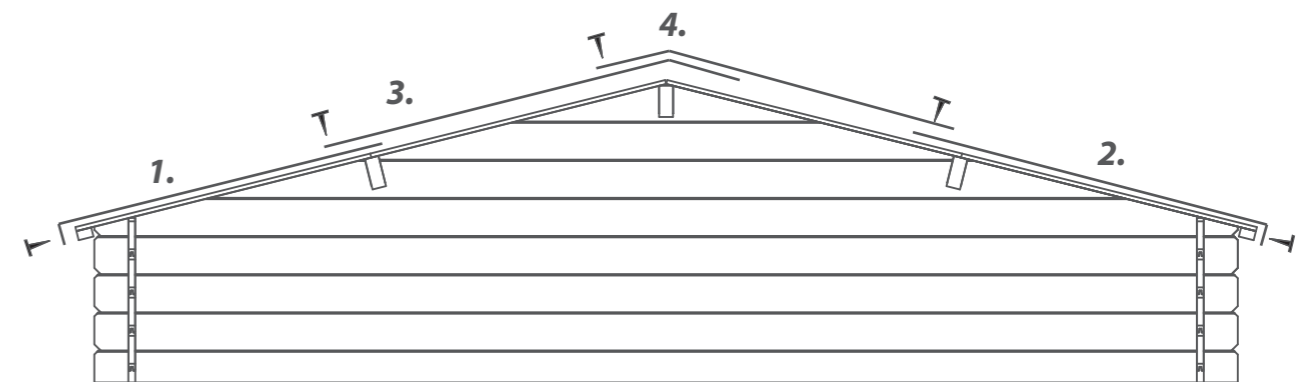
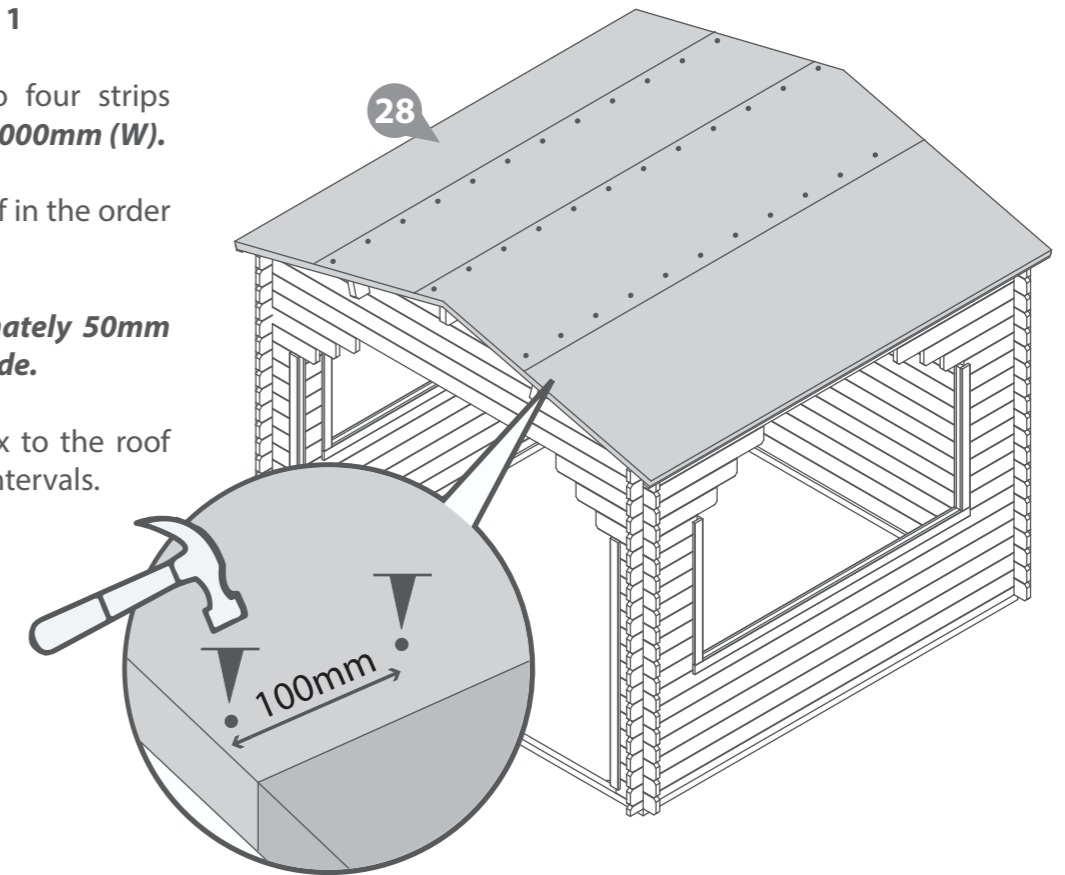

Step 17
Parts needed - No. 24 QTY 4
No. 25 QTY 2

Locate the Fascias (No. 24) onto the sides of the log cabin, and the Fascias (No. 24) onto the front and back of the log cabin. Align with the roof and ensure to trap the felt.

Secure in place using 3x40mm screws per fascia, making sure to screw through the fascia into the roof purlins and eaves frame.

The Fascias will need to be cut down to the correct size.

***Ensure the angled cuts meet at the top of the apex.**

18x40mm Screws

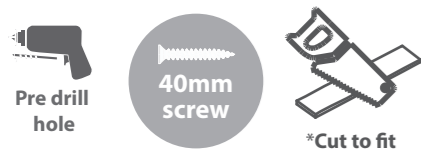

Step 18
Parts needed - No. 21 QTY 2
No. 22 QTY 2
No. 23 QTY 4

Locate the Door Frame Trims, Window Cill Trims and Window Frame Trims (No.21, 22 & 23) onto the Door and Window Frames (No.15, 16 & 17) on either side of the log cabin, as shown, ensuring they are flush and level.

Secure in place using 3x40mm screws per trim, making sure to screw through the trim into the framing of the frames behind.

24x40mm Screws



IMPORTANT : Pre-drill before fixing screws.

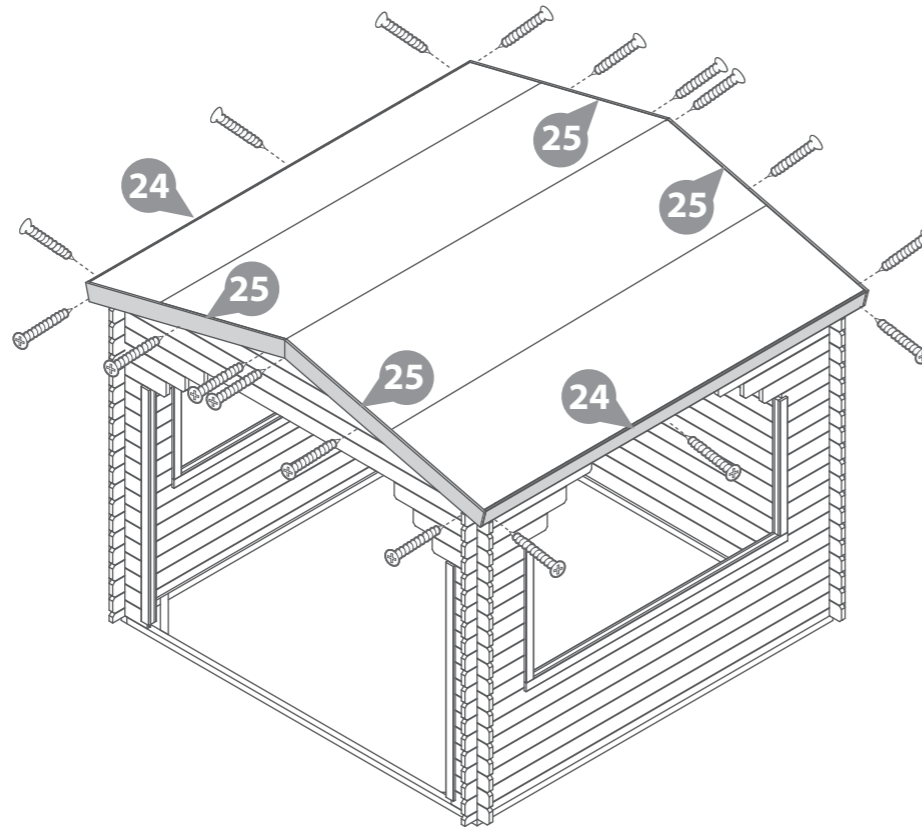

IMPORTANT : Pre-drill before fixing screws.

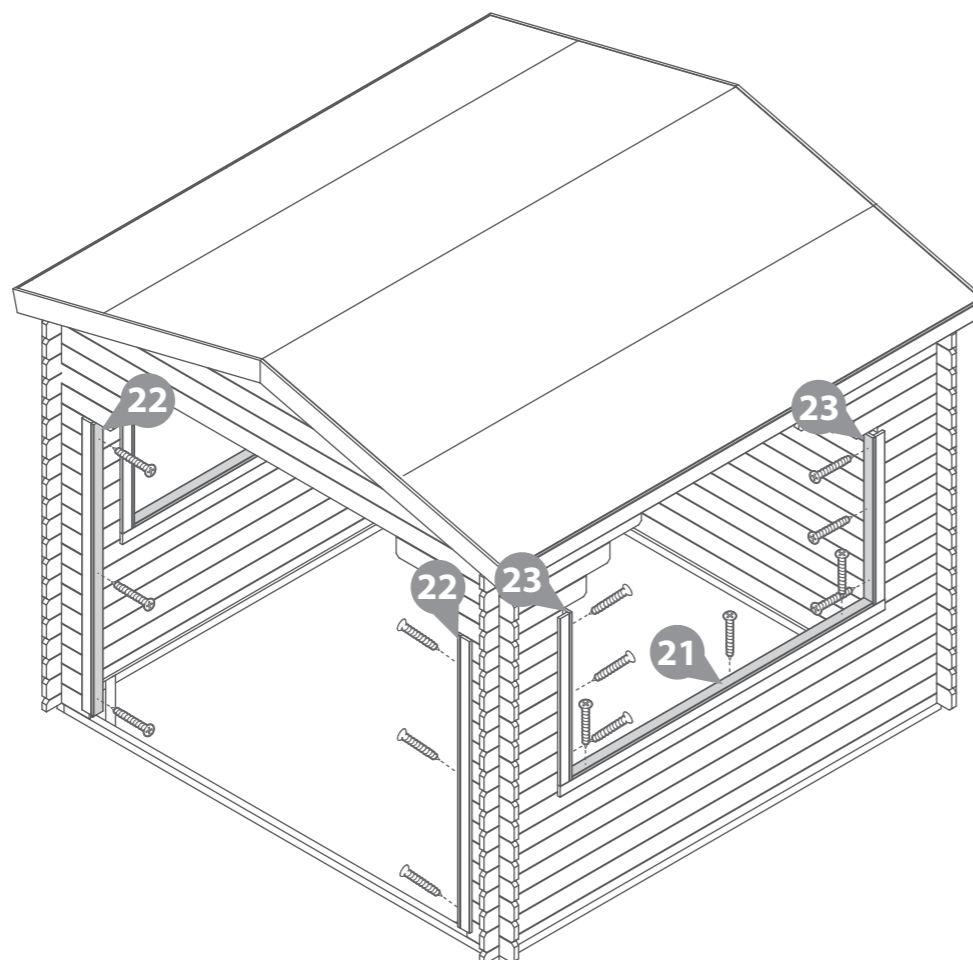

Step 19
Parts needed - No. 26 QTY 8

Arrange the storm braces (No.26) around the building (*internally*), Placing two storm braces per side, fixing into place using 2x70mm bolts per brace, making sure the washer & nut are tightened from the outside of the building.

***Ensure the storm braces are secured at the highest point possible on each side.**

The storm braces will need to be altered during the buildings life as the moisture content within the log boards changes. The boards will expand during periods of high moisture (Winter) and shrink during periods of low moisture (Summer.)

****Storm braces will help your building expand and contract properly.**

*****Important: Ensure each bolt is tightened using a washer so as not to damage the log boards.**

16x70mm Bolt Sets

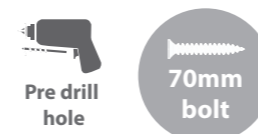

IMPORTANT : Pre-drill before fixing screws.

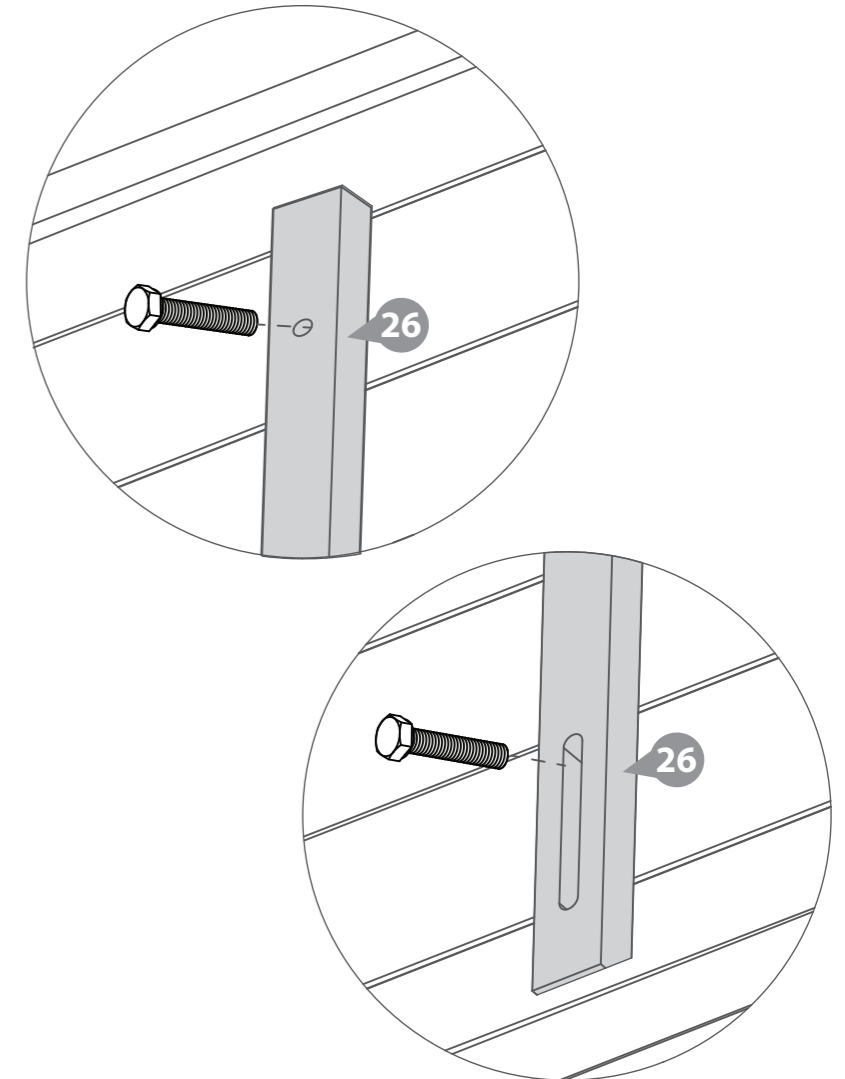

TREATING YOUR GARDEN BUILDING

Preservation of wood that's outdoors is vital. A little early care will help protect your garden building, improve its appearance and ensure maximum longevity. Insects, moisture, salt, and changing weather can have dramatic effects on the stability and appearance of your garden building. Once your building is installed, you've checked it over and you're happy with it, you can take a few basic precautions to prepare it for the elements. Treating your garden building helps prevent decay and, by repelling water, discourages the growth of moulds and fungi that could jeopardise the structural integrity of the wood.

Dip Treated buildings - Require a preservative treatment to protect against rot and decay and a waterproof treatment to prevent water ingress
Pressure Treated buildings - Require a waterproof treatment to prevent water ingress
Log Cabins/Insulated Garden Rooms - Are supplied untreated and require a preservative and waterproofing treatment.



ANY QUESTIONS?
CONTACT US ON
01636 821215

To apply a preservative and water proofing treatment (pressure treated products do not require a preserver), follow the manufacturer's instructions but in principle, stick to the following steps:

- ✓ Wear latex or rubber gloves, eye protection and (if spraying) a mask.
- ✓ Prepare the wood, by sanding down any ridges or inconsistencies in the wood, smoothing out knots and end-cuts.
- ✓ Choose a dry day to treat your garden building. If you're spraying rather than brushing paint on, avoid a windy day.
- ✓ Be sure you can safely reach all the sections you need to paint - and if you need a ladder, make sure it's safely positioned before climbing. Lay dust sheets around to avoid paint splatters on your base or surrounding plants.
- ✓ Tape around windowpanes to avoid smears when you're painting the frames.
- ✓ Keep pets and small children out of the way. The last thing you want is to have fur on your garden building paint, or little painted footprints all over your garden and home.
- ✓ Fill any gaps in the building's body with caulk or wood filler to prevent water and draughts getting in. Silicone based caulk is flexible and will move with the timber when temperature and humidity change. Allow to dry completely before treating. A handy tip for finding gaps is to go into your garden building and look for light leaking through joints and frames. If light gets in, then so will water.
- ✓ Liberally apply at least two coats of the treatment products with a brush or spray, taking care to allow the first coat to completely dry before applying the second.
- ✓ Make sure the solution permeates the whole of the surface area, especially around natural cracks, end cuts and nail/screw holes.



APPLY WOOD TREATMENT
IMMEDIATELY
AFTER ASSEMBLY

PLEASE SCAN HERE TO
SEE TREATMENT VIDEO:



1 Perimeter

Check around the perimeter of your product to ensure there are not trees or plants that are in contact with or overhanging the building. This can affect airflow and overhanging trees, or branches can damage the roof, it is advised to keep plants at a distance.

2 Repair

Inspect the interior and exterior of the product to look for splits, cracks, and holes. Although this is a natural occurrence it can be prevented. A wood filler can be used to close the splits, cracks, and holes.

3 Roof

Check your roof regularly for tears, splits, damaged wood and fallen debris. If you notice any of this immediate repair is critical.

4 Doors & Windows

Expansion and contraction can cause doors and windows to stick or become difficult to open. Small adjustments to the hinge position can be made to the doors and windows to allow free movement.

5 Oil

Hinges can seize up over time, apply lubricant to the hinges and locks annually.

6 Screws & Bolts

It is advised to check all screws and bolts and tighten any loose you might find. For log cabins specifically the storm braces will require loosening. During humidity and temperature changes (seasons) to allow expansion and contraction to prevent gaping, twisting, popping, and warping.

7 Wash

At least once a year, give the outside of you building a good wash, to remove cobwebs, leaves, or any other dirt that may accumulate on the exterior.

8 Airing

Airing your product regularly prevents the build up of condensation which can cause the timber to rot and mould. Condensation can build up over time or daily, it is caused by a rise and fall in temperature. Leaving doors and windows open regularly can help combat the natural moisture build up.

9 Clean & Tidy

It is good practice to clean the inside and outside of your product regularly. Clear out the contents, sweep the floor, remove dirt and cobwebs. Check for areas of damp and investigate the cause to remove and prevent future occurrences. Check the ground around your product for build up of debris such as leaves, remove and ensure there is clear ventilation underneath the floor.

Additional Playhouse Maintenance:

It is recommended that the following checks and maintenance are carried out at the beginning of each season as well as at regular intervals during the usage season.

- Check all nuts /bolts/ screws for tightness and tighten when required.
- Check for movement / opening of wood giving rise to protrusion of nail heads and tips.
- Check hinges.
- Replace defective parts in accordance with the manufacturers instructions.
- Check any crossbeams, suspensions and anchors.
- If a swing is included; check the swing seat, chains and ropes.

IF THESE CHECKS ARE NOT CARRIED OUT THE ACTIVITY TOY COULD BECOME A HAZARD

All our garden buildings have been designed and manufactured with care and attention to be the perfect addition to your outdoor space. To ensure you do get the best out of your new garden building and to increase the longevity we advise that you follow the product instructions and our manufacturer's recommendations as detailed below. Thank you for choosing a Mercia Garden product!

1 Choosing the most suitable location for your garden building...

A minimum of 60cm should be left around the perimeter of your garden building to allow access for maintenance, annual treatment and to allow air flow around the building.

Where possible you should avoid placing your garden building underneath large trees to prevent the tree causing damage to the building.

2 Preparing the base for your garden building...

All our buildings must be built on a firm, level base to ensure the longevity of the building and prevent the wood from distorting. We recommend either concrete, concrete slabs or a wooden base, such as our 'Portabase'.

The base should be slightly smaller than the external measurement of the building, i.e. the cladding should overlap the base, creating a run off for water and preventing water from pooling underneath the building.

We also recommend that the floor of the garden building is a minimum of 25mm above the surrounding ground level to avoid flooding.

3 After installation...

Once your garden building has been installed, it will need to be treated within 14 days (weather permitting) and annually to prevent the timber from deteriorating and to waterproof it. This is required to maintain the anti-rot guarantee.

Dip Treated buildings - Require a preservative treatment to protect against rot and decay

and a waterproof treatment to prevent water ingress.

Pressure Treated buildings - Require a waterproof treatment to prevent water ingress.

Log Cabins/Insulated Garden Rooms - Are supplied untreated and require a preservative and waterproofing treatment.

We also recommend using a silicon sealant on the inside and outside of the windows as soon as possible after assembly and treatment to fully seal the windows.

Roofing felt/covering should be checked annually and replaced or fixed accordingly.

4 General maintenance and wood characteristics

As wood is a natural material it may be affected by the following:

Shrinkage and warping - The timber used in the construction of your garden building will have retained some of its natural moisture content. The moisture content of the timber will vary, depending upon prevailing environmental conditions, which will result in the components either naturally expanding or contracting. As the components dry out, shrinkage may occur. A good waterproofing treatment from the start is the best protection to minimise the effect of moisture loss/intake.

In extended periods of very warm weather getting some moisture to the building will help the overall balance. You can do this by spraying it down lightly with a garden hose. In contrast, after snow fall try to remove the snow as best as possible from the roof to prevent moisture intake and to remove the extra weight.

Top tip - using a garden brush will help you to reach the highest part of the building to remove snow and any debris left from bad weather.

Damp and mould - During the winter months, cold and damp conditions can result in an increased amount of moisture within your garden building, especially when used infrequently. Condensation can form on the timber and other items stored within your garden building. If left this moisture is likely to cause mould and mildew.

To prevent the build-up of moisture, we recommend leaving the door or windows of your building open from time to time, to allow the fresh air to circulate. We also advise against storing wet or damp items in your garden building as this will also increase the level of moisture in the building. If mould or mildew does start to form within your building we recommend using an anti-mould cleaner to remove it and to prevent it spreading, which if left untreated could permanently damage your garden building.

Splits, cracks and knots - You may notice small splits and cracks in some components or holes may appear where knots shrink and fall out. This will not affect the structure of your Garden building however, if you wish to fill them this can be easily done using any good quality wood filler.

Sap - is naturally occurring in wood and may appear in some boards of your garden building. If you wish to remove the sap, we advise waiting until it is dry and then using a sharp knife to carefully remove it. If the removal of the sap causes a hole in the timber, we recommend using a good quality wood filler to fill it.

For more handy hints and tips on how to care and maintain your garden building please refer to the MGP Customer Portal at www.mgplogistics.co.uk

Any further questions?

Contact our
Customer Service
Team on:
01636 821215

1

Manufacturer's Warranty

All Mercia Garden Products are supplied with a 1 year warranty on all parts against manufacturing defects.

This warranty does not cover movement, warping or splitting of timber products over time.

This warranty will be voided if any of the following occur:

1. The building has been customised or modified/adapted in any way.
2. The person claiming is not the original purchaser of the building.
3. Any damage has been caused by or as a result of misuse.
4. The building has not been maintained and cared for in accordance to our advisories and manufacturer's recommendations.
5. The building has not been treated annually or as per the manufacturer's recommendations, please ensure receipts are kept to validate this claim.
6. The building has not been erected, fitted or installed as per the supplier instructions.
7. The building has not been erected on a suitable sized firm flat, solid level concrete/slab base or placed on pressure treated bearers.
8. The building is or has been placed with 2 feet (600mm) of any obstructions (walls, trees, plants, fences etc.) which can allow moisture to penetrate the timber.
9. The roofing felt has been incorrectly fitted or damaged, allowing water ingress, or has not been properly maintained.
10. Any windows and joints have not been sealed, inside and out, with silicone or other watertight sealant.
11. Any timber has been cut, pierced or drilled without subsequent application of approved cut-end treatment.

2

Anti-rot Guarantee

Mercia Garden Products offer a 10 year anti-rot guarantee on all dip treated (a preparatory treatment) and 15 years on all pressure treated products. This guarantee covers solid timber against rot, decay, blue stain and insect attacks.

To validate the guarantee the building must be treated (as detailed within manufacturer's recommendations) within 14 days (weather permitting) of assembly and annually thereafter.

This guarantee does not cover movement, warping or splitting of timber products over time.

This guarantee will be voided if any of the following occur:

1. The building has been customised or modified/adapted in any way.
2. The person claiming is not the original purchaser of the building.
3. Any damage is caused by or as a result of misuse.
4. The building has not been maintained and cared for in accordance to our advisories and manufacturer's recommendations.
5. The building has not been treated annually or as per the manufacturer's recommendations, please ensure receipts are kept to validate this claim.
6. The building has not been erected, fitted or installed as per the supplier instructions.
7. The building has not been erected on a suitable sized firm flat, solid level concrete/slab base or placed on pressure treated bearers.
8. The building is or has been placed with 600mm of any obstructions (walls, trees, plants, fences etc.) which can allow moisture to penetrate the timber.
9. The roofing felt has been incorrectly fitted or damaged allowing water ingress, or has not been properly maintained.
10. Any windows and joints have not been sealed, inside and out, with silicone or other watertight sealant.
11. Any timber has been cut, pierced or drilled without subsequent application of approved cut-end treatment.



REGISTER FOR YOUR
ANTI-ROT
GUARANTEE TODAY

PLEASE SCAN HERE:

