

ULTRAMAX

ULTRA QUALITY MAX POWER

Smart State of Charge (SOC) Meter



Installation & User Manual

(Model: SOCUMX-30A / up to 600A with external shunts and/or coils)

1. Introduction

The Ultramax SOC Meter is an advanced monitoring device designed to measure, calculate, and display the State of Charge (SOC), current (I), and voltage (V) of multi-channel battery systems. It supports both parallel and series-connected batteries, making it suitable for various energy storage applications.

The SOC meter can communicate wirelessly via Bluetooth Low Energy (BLE 5.0) for real-time monitoring through a mobile app, and via CAN Bus (VE-CAN / CI-BUS) for integration with inverter-chargers and other energy management devices.

Key Features:

- 4 independent measurement channels
- External shunt resistor supports up to 600 A total current
- External coil supports up to 600 A total current
- High accuracy ($\pm 2\%$) with 16-bit resolution
- Bluetooth LE (up to 100 m range)
- CAN / LIN-CI BUS interface for system integration
- Compact and durable enclosure suitable for harsh environments
- Typical Applications:
 - Marine and RV battery banks, • Solar and hybrid energy systems
 - Industrial and telecom power systems

2. Technical Specifications

Parameter	Specification
Voltage range	0 – 32 V
Maximum current (with external shunt)	Up to 600 A
Resolution	16-bit
Accuracy	±2%
No. of Channels	4 (each up to 30A internal or higher via external shunt)
Operating Temperature	-20°C to +85°C
Storage Temperature	-40°C to +125°C
Connectivity	Bluetooth LE v5.0, CAN (VE-CAN), LIN (CI-BUS)
Battery Compatibility	Lithium-ion / Lead-acid up to 29.5 V
Enclosure Dimensions	19.7 × 5.9 × 4 cm
SOC Estimation Method	Coulomb counting
Mobile App	iOS and Android compatible
BLE Range	≤ 10 m (line-of-sight)

Note-1: For high-current applications, external shunt resistors are mandatory. The meter comes without internal 30A resistors unless specified.

Note-2: All batteries (up to 4) should be of same voltage and capacity connected to SOC meter. Eg: All 12v or 24-volt batteries but not mixed.

Note-3: Full scale drawing of SOC Meter available at the end of the document.

3. System Overview

The SOC meter continuously measures current and voltage from up to four battery circuits through connected shunt resistors (internal or external) or coils. Using enhanced coulomb counting, it estimates the battery's State of Charge (SOC) and transmits data to the user interface and charger-inverter.

Functional Highlights:

- Each input channel can monitor one battery line independently.
- The system can monitor combined current for parallel or series configurations.
- Bluetooth module transmits data to paired mobile app for visualization.
- CAN/LIN interface shares data with inverter/charger systems for intelligent energy management.

4. Pictorial Connections and Wiring

4.1 Parallel Batteries with Shunt

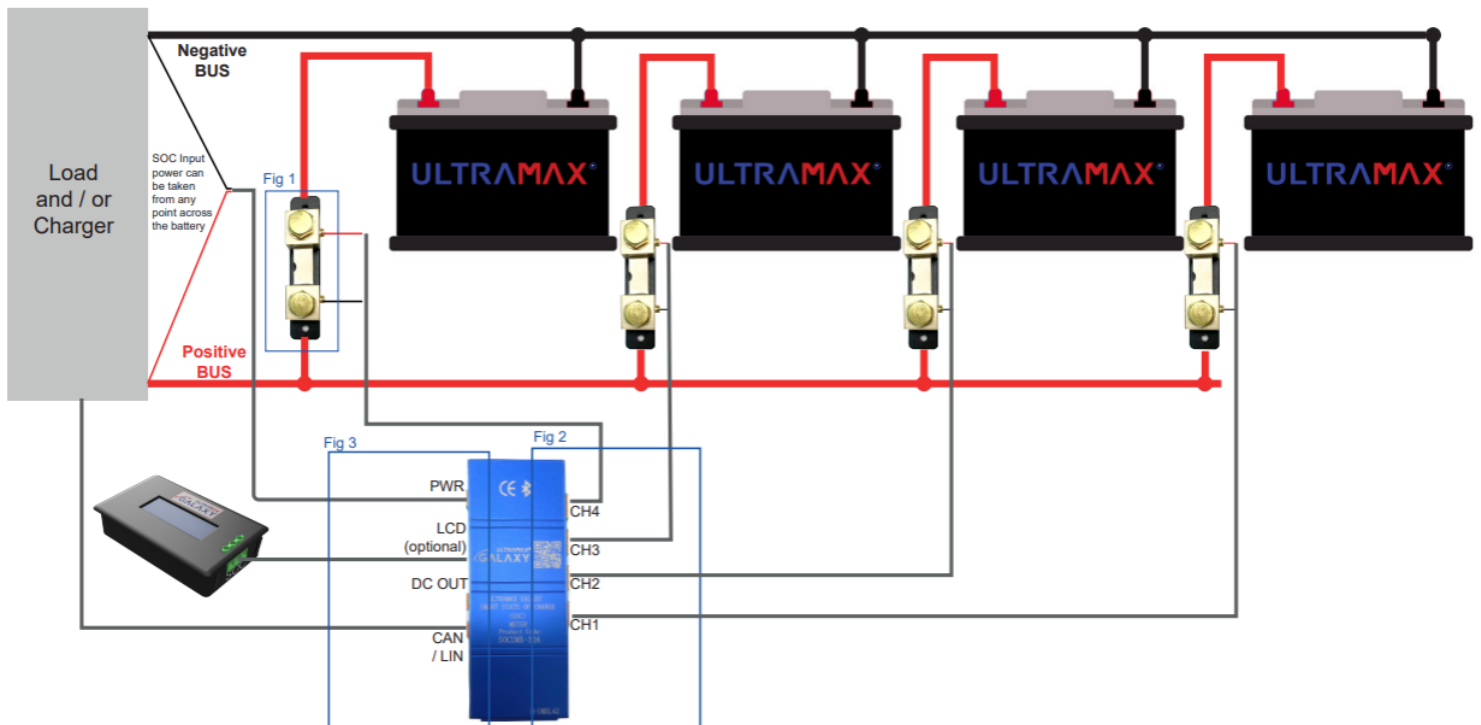

Fig: 4.1

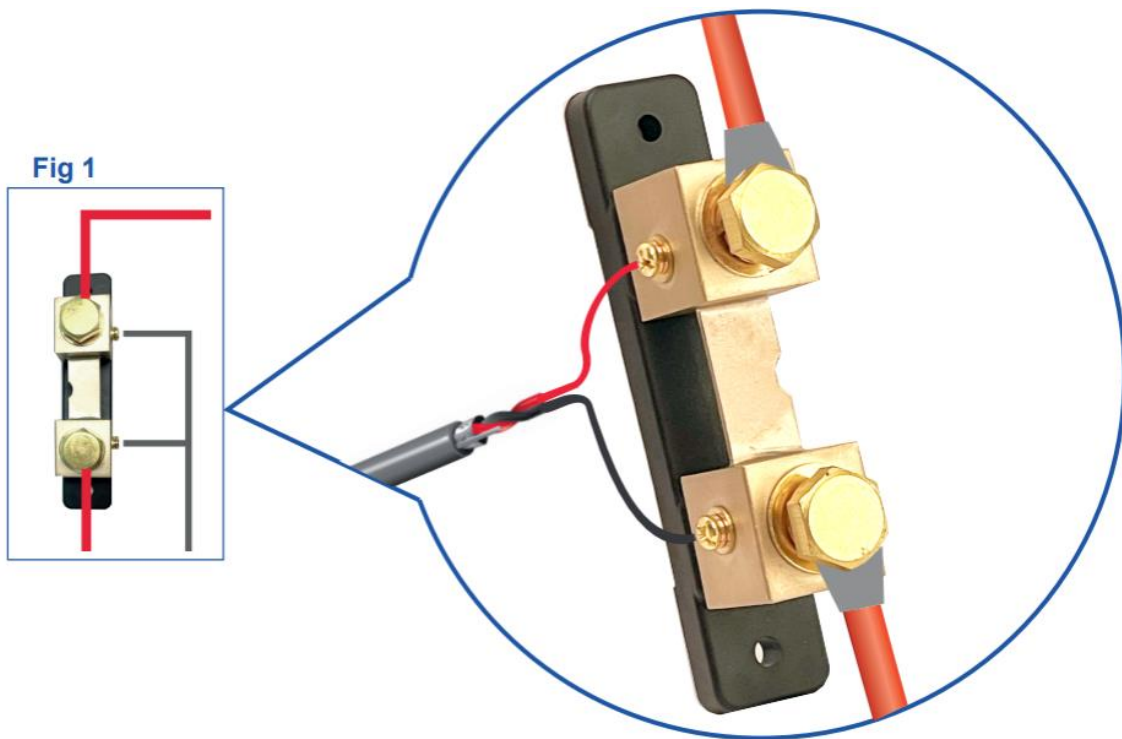

Fig: 4.1.1 (Zoomed out from fig 4.1)

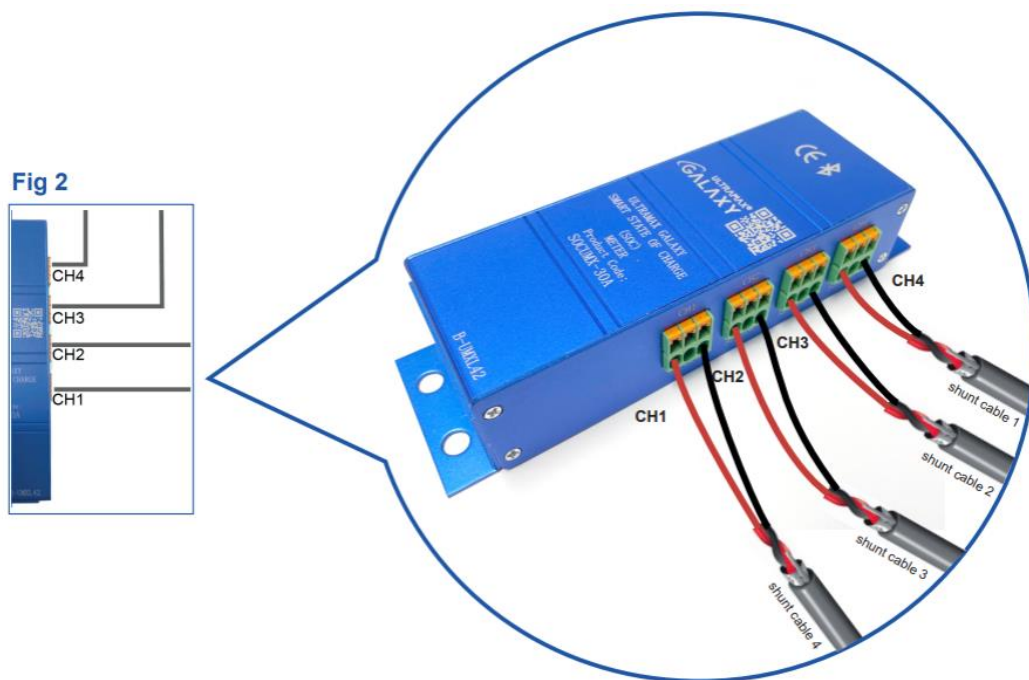

Fig: 4.1.2 (Zoomed out from fig 4.1)

Fig 3

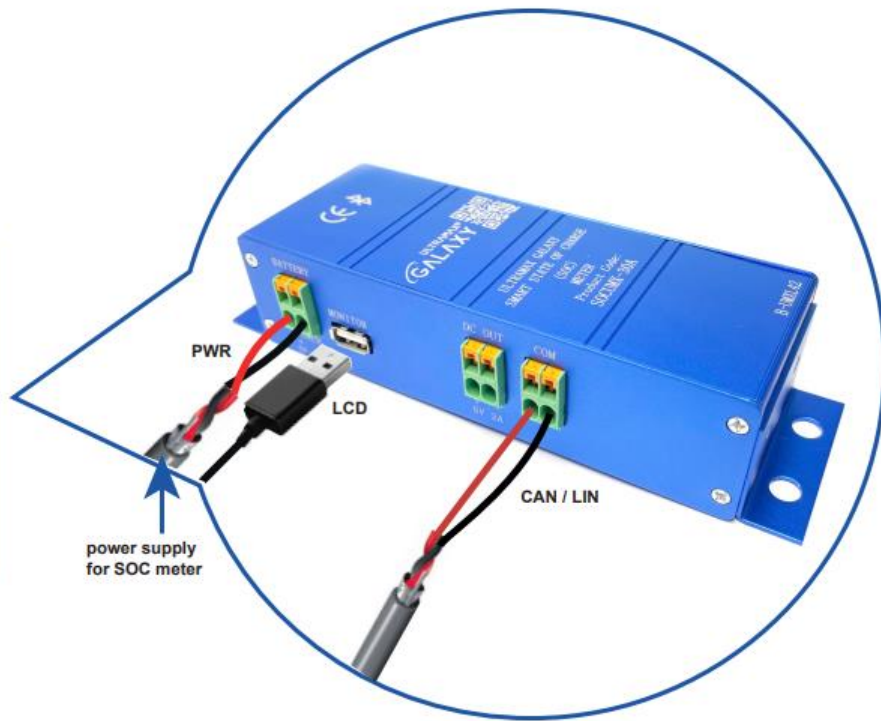
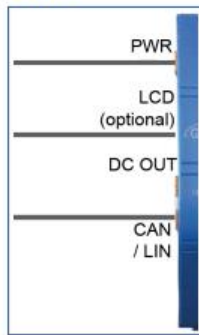
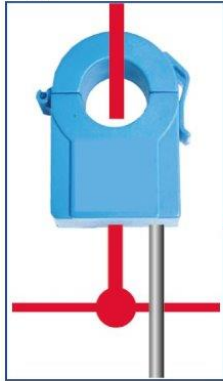

Fig: 4.1.3 (Zoomed out from fig 4.1)

Fig 1



Coil (type 1)

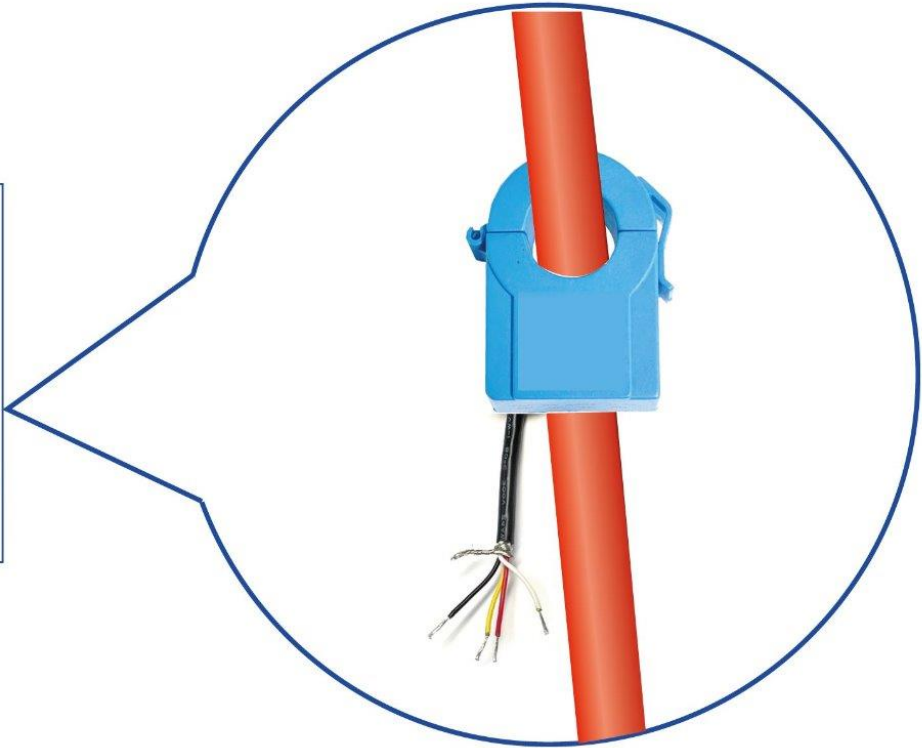

Fig 1



Coil (type 2)

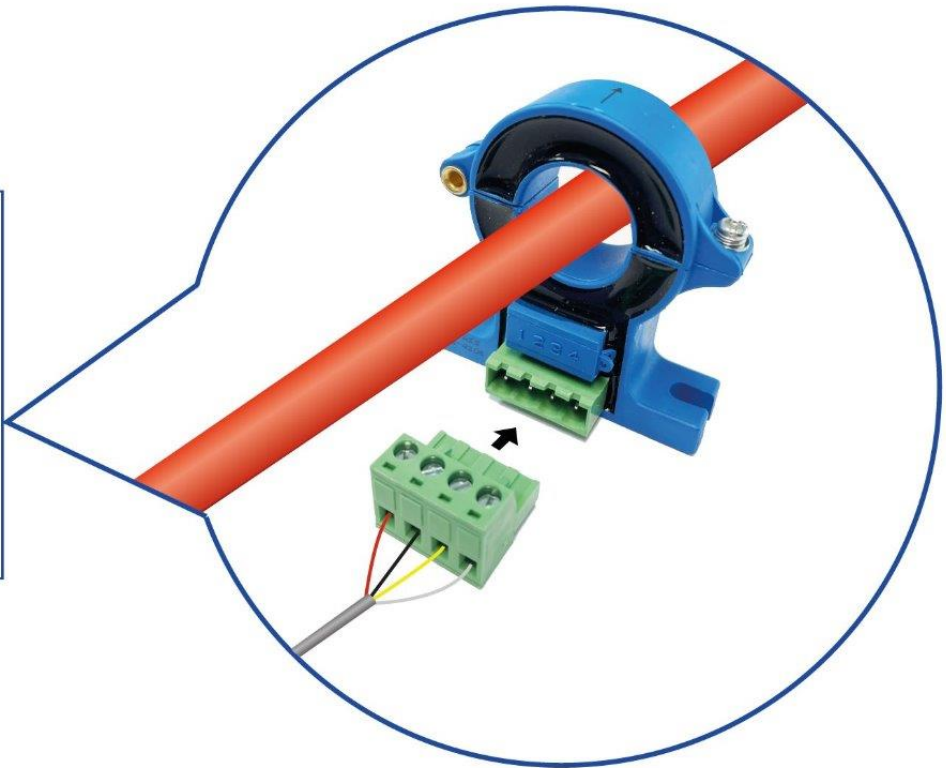

Fig: 4.2.1 (Zoomed out from fig 4.2)

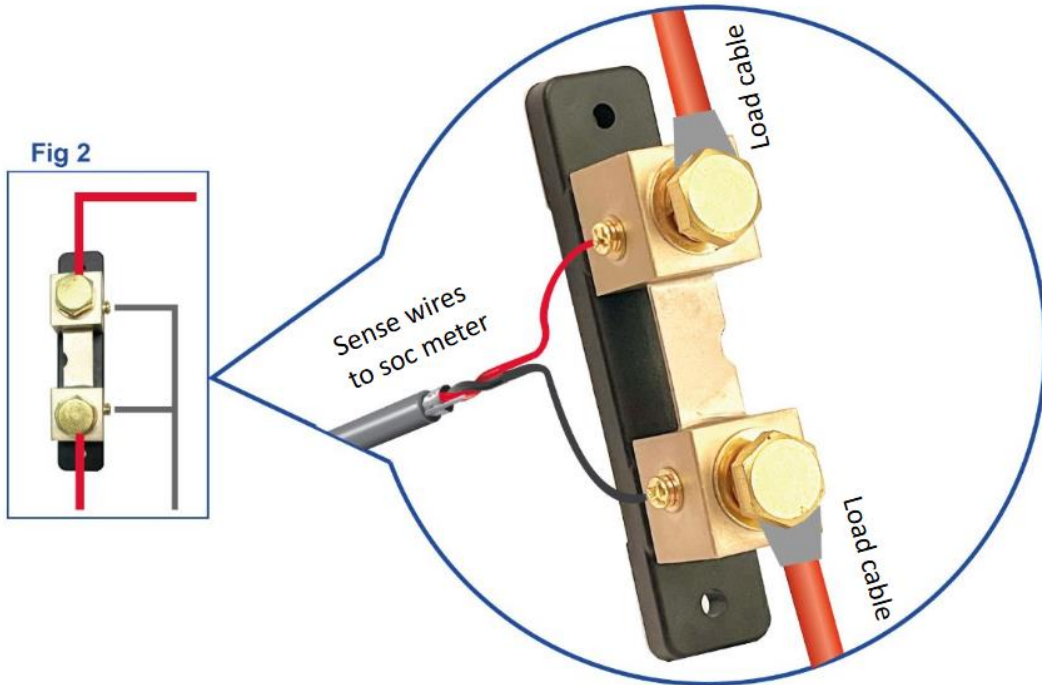

Fig: 4.2.2 (Zoomed out from fig 4.2)

SoC Meter Channels Side Connections.

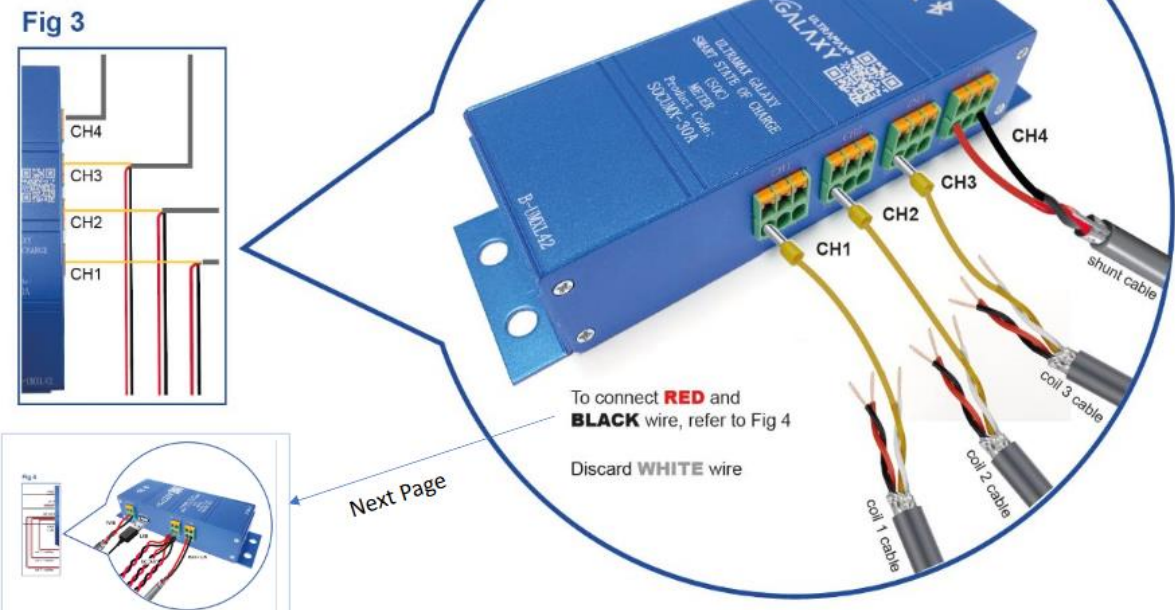

Fig: 4.2.3 (Zoomed out from fig 4.2)

SoC Meter Power connector side connections

Fig 4

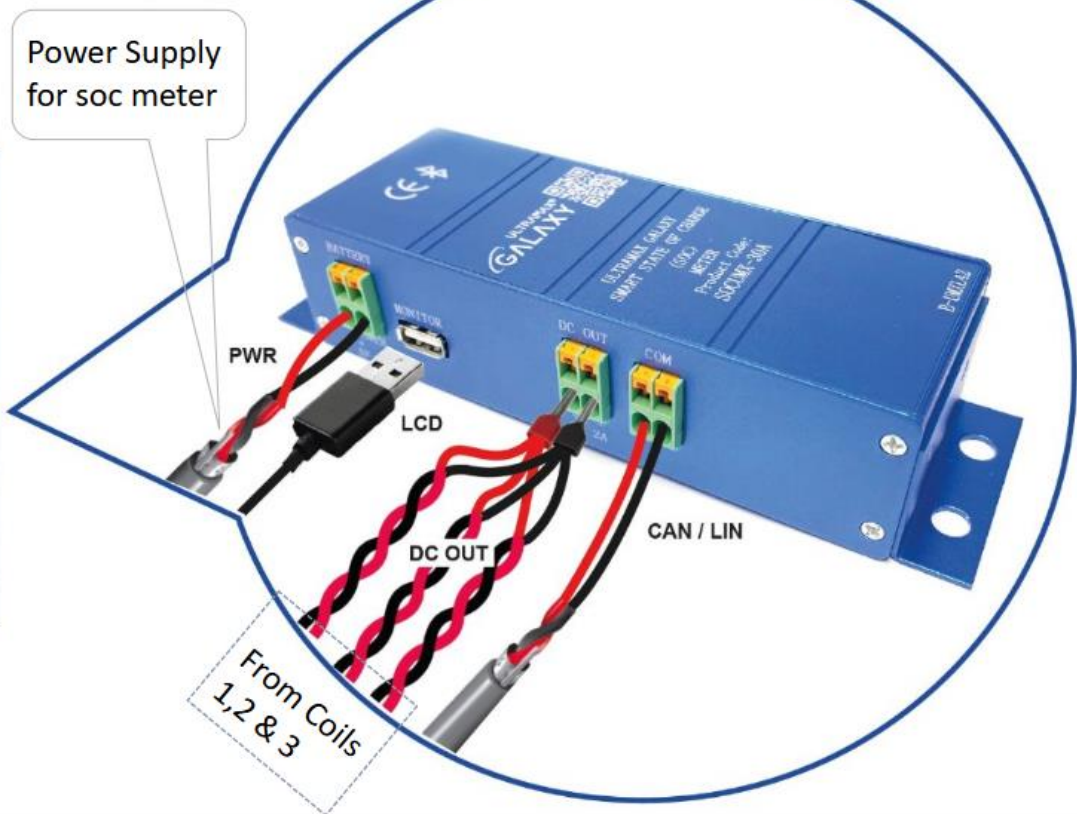
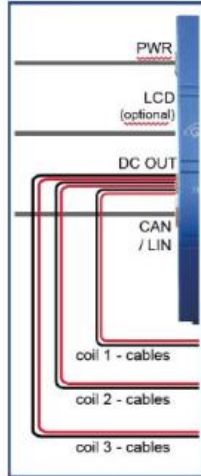

Fig: 4.2.4 (Zoomed out from fig 4.2)

4.3 Series Connected Batteries with Shunt

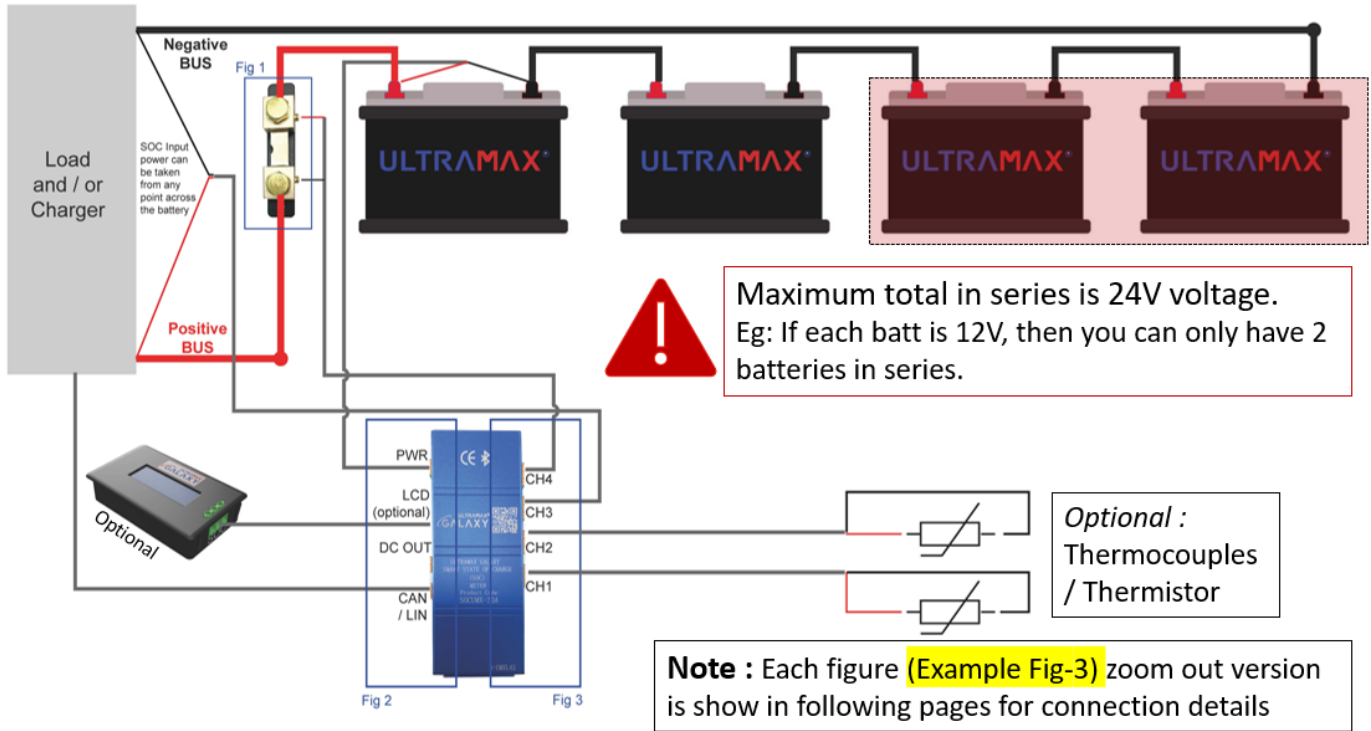

Fig: 4.3

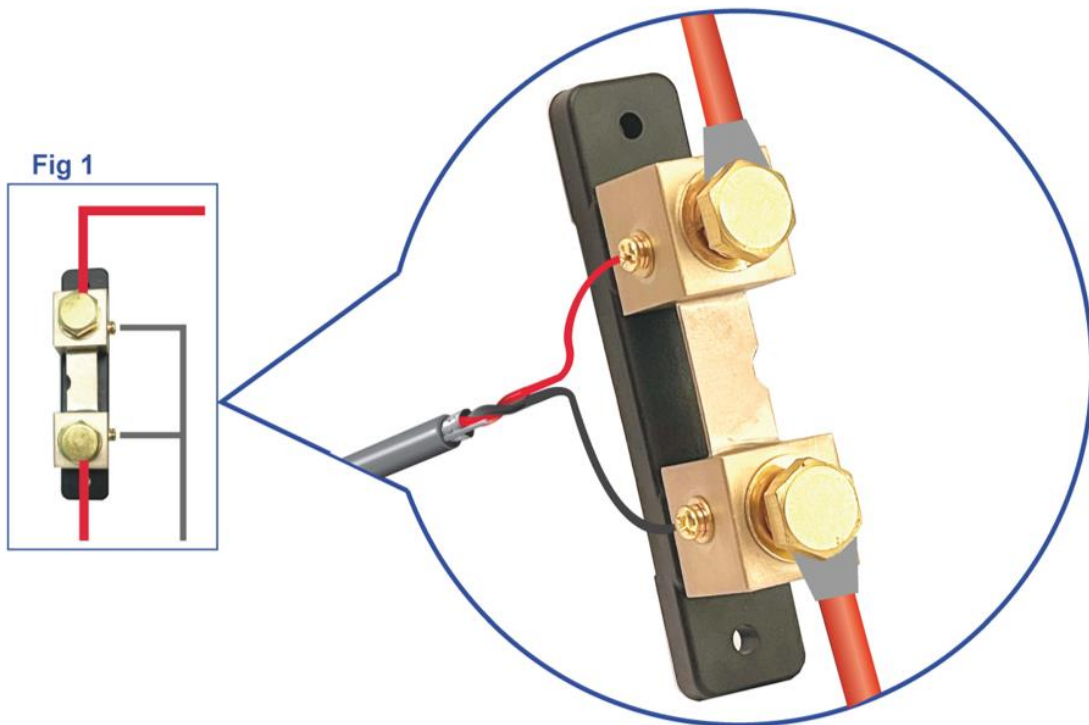

Fig: 4.3.1 (Zoomed out from fig 4.3)

Fig 2

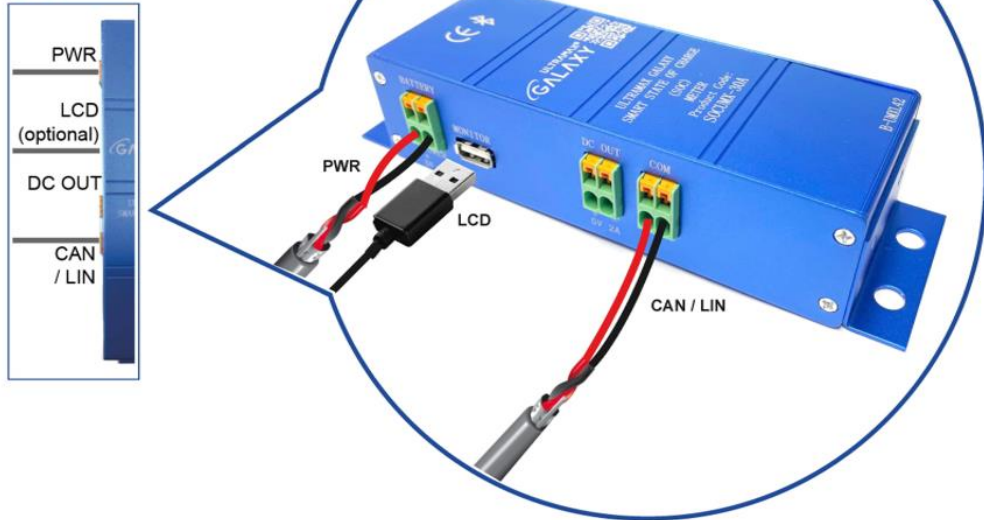

Fig: 4.3.2 (Zoomed out from fig 4.3)

Fig 3

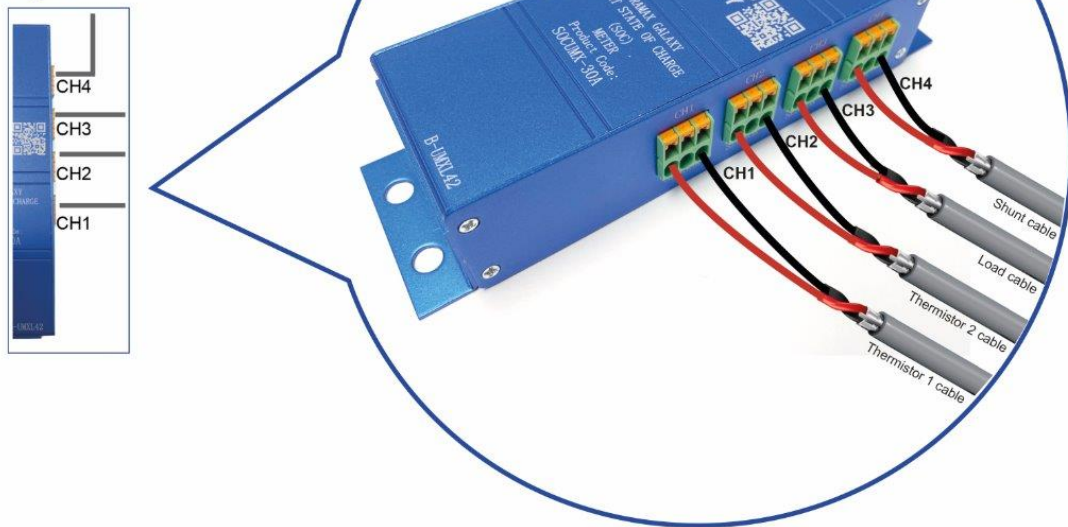

Fig: 4.3.3 (Zoomed out from fig 4.3)

Fig 4

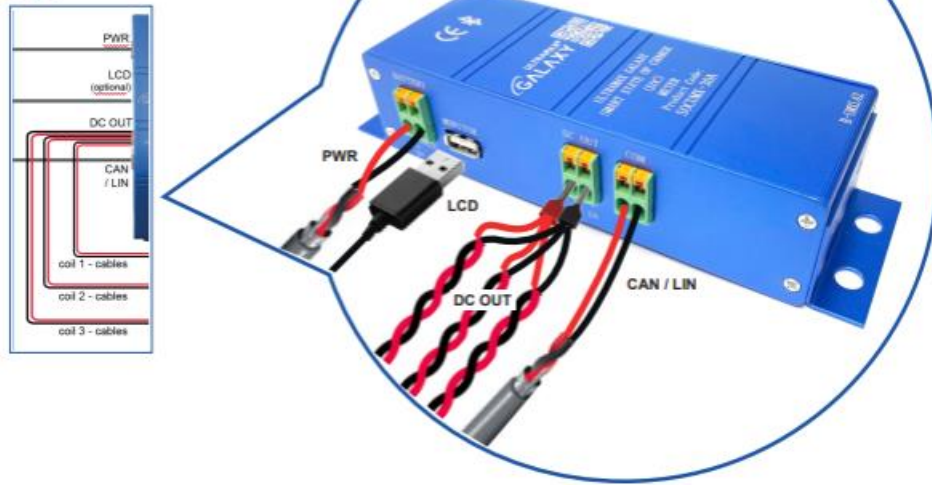

Fig: 4.4 .2(Zoomed out from fig 4.4)

Fig 3

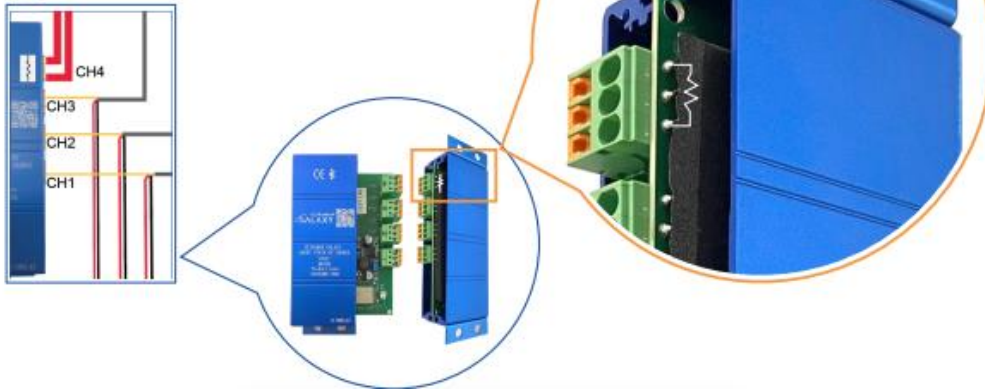

Fig: 4.4 .3(Zoomed out from fig 4.4)

4.x All the shunts can be replaced by coils and vice versa, depending upon the application. We also support special use cases to support customer needs.

[Contact us: <https://ultramax.co.uk/>]

5. Installation Procedure

1. Mounting: Install in dry and vibration-free location.
2. Wiring: Disconnect batteries before connecting shunts and sense leads.
3. CAN Bus: Connect CAN H/L with 120 Ω termination.
4. Power-Up: Verify all connections before applying power.
5. Safety: Use insulated tools and correct wire gauges.
6. Ensure the SOC box is placed as close as possible to the shunts.
7. Use a twisted shielded cable for use between the shunt and the SOC meter for example (rs components - Mfr. Part No: 5471C SL005)

6. Configuration

(Using Wi-Fi Page)

6.1 Go to phone setting → Wi-Fi → Find the SOCMETER_AP and connect

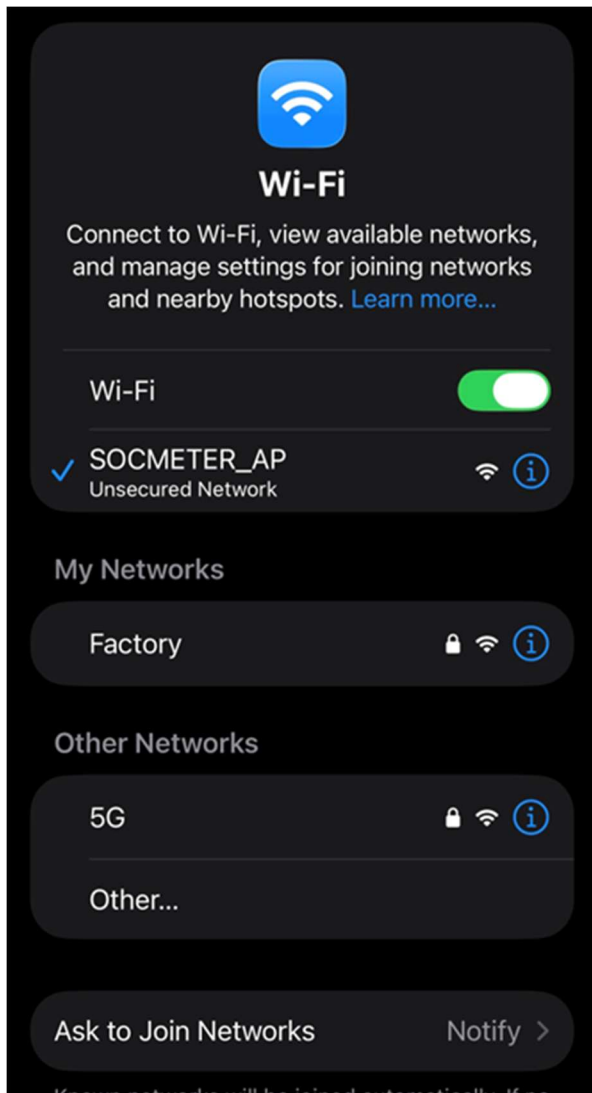

6.2. Go to the browser (Chrome, Safari or any browser). On the search bar, type this IP address “192.168.4.1” and you will see this screen

6.3. To setup the parameter, go to parameter settings. In the parameter settings, there are

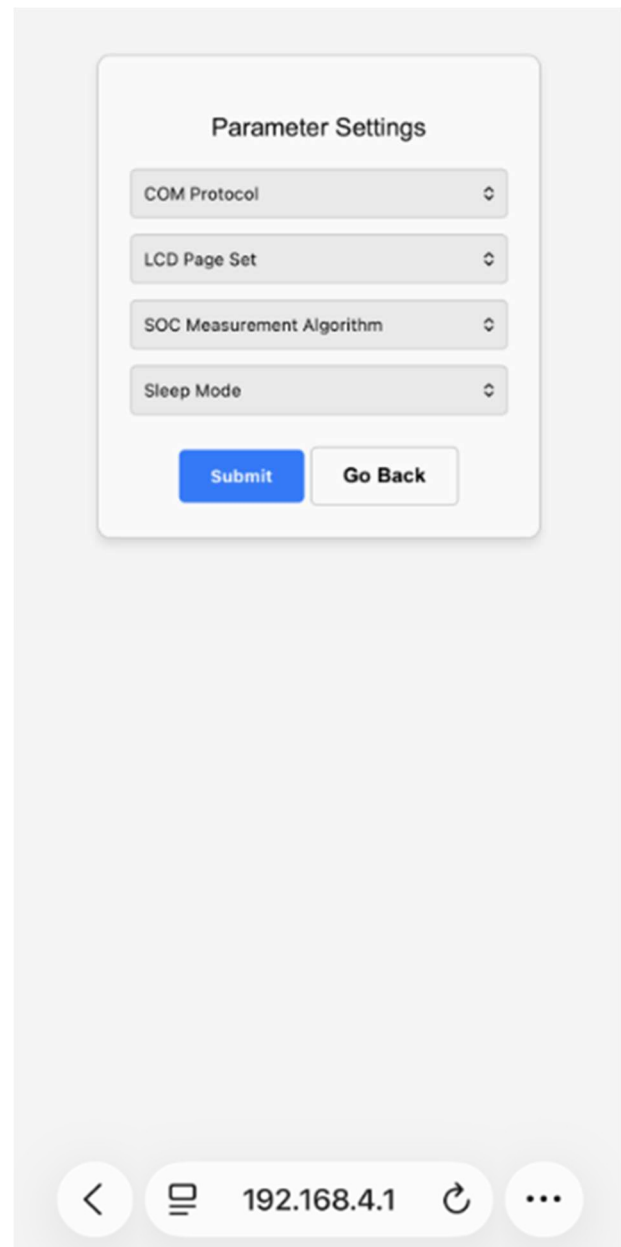

6.3.1. COM Protocol → CAN, LIN or None (For wire communication)

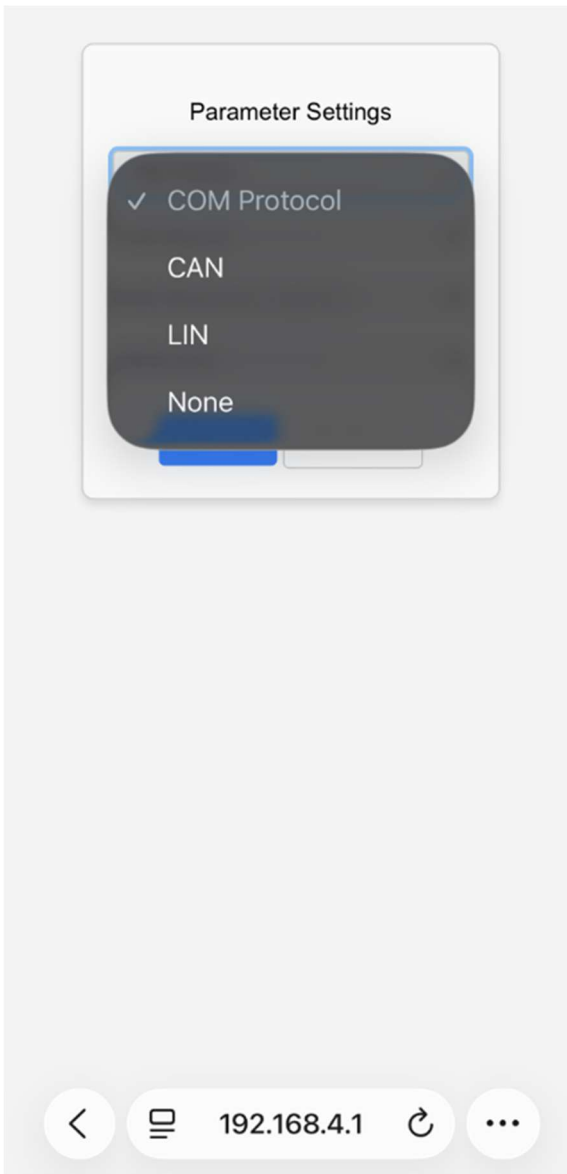

6.3.2. LCD Page Set → Channel 1 - 4 or Total or Loop or Off (To select which screen should show on LCD)

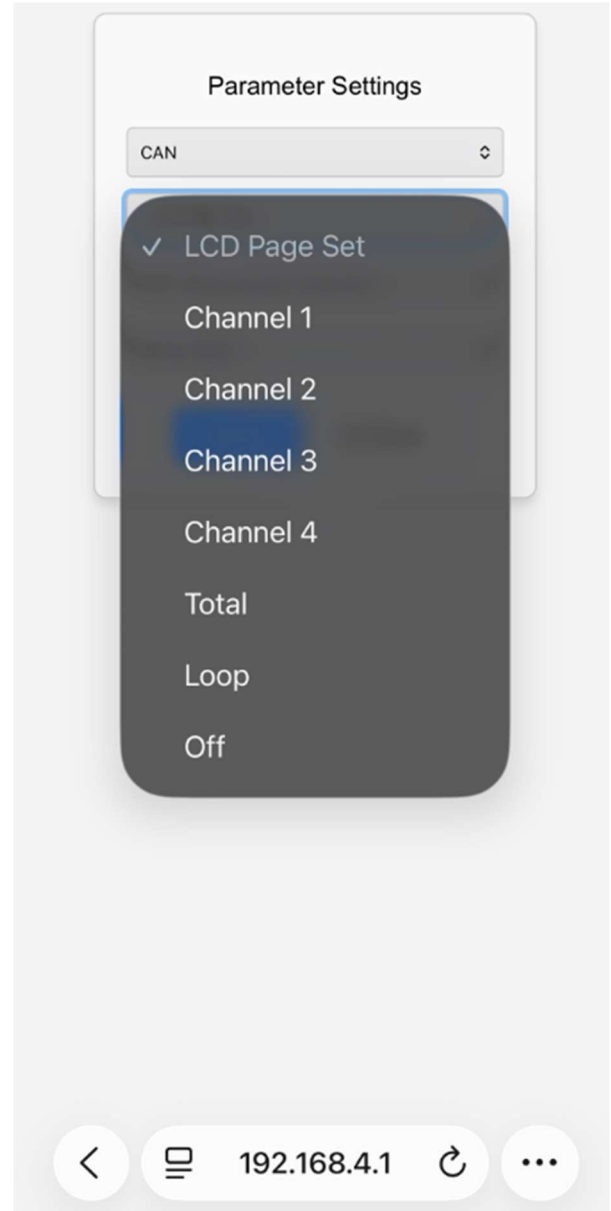

6.3.3. SOC Algorithm → Battery Model and Coulomb Counting (CC is only option here, battery model is for future reserve)

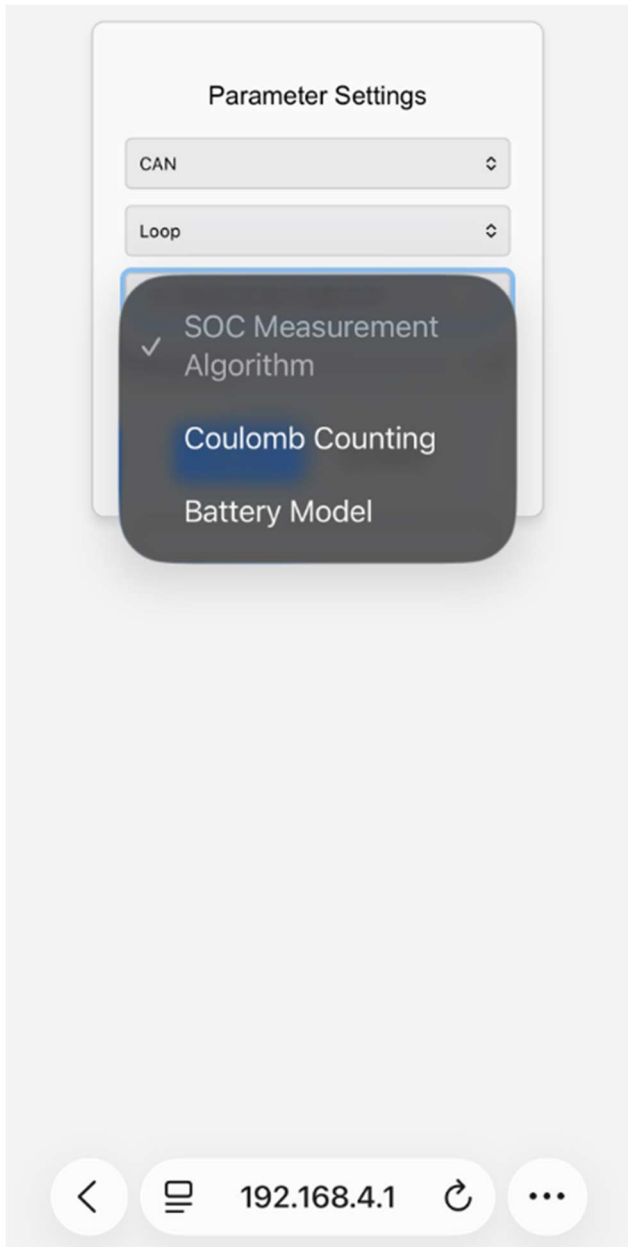

6.3.4. Sleep Mode → Disable and Enable (If sleep mode is enable, you need to input the sleep timer)

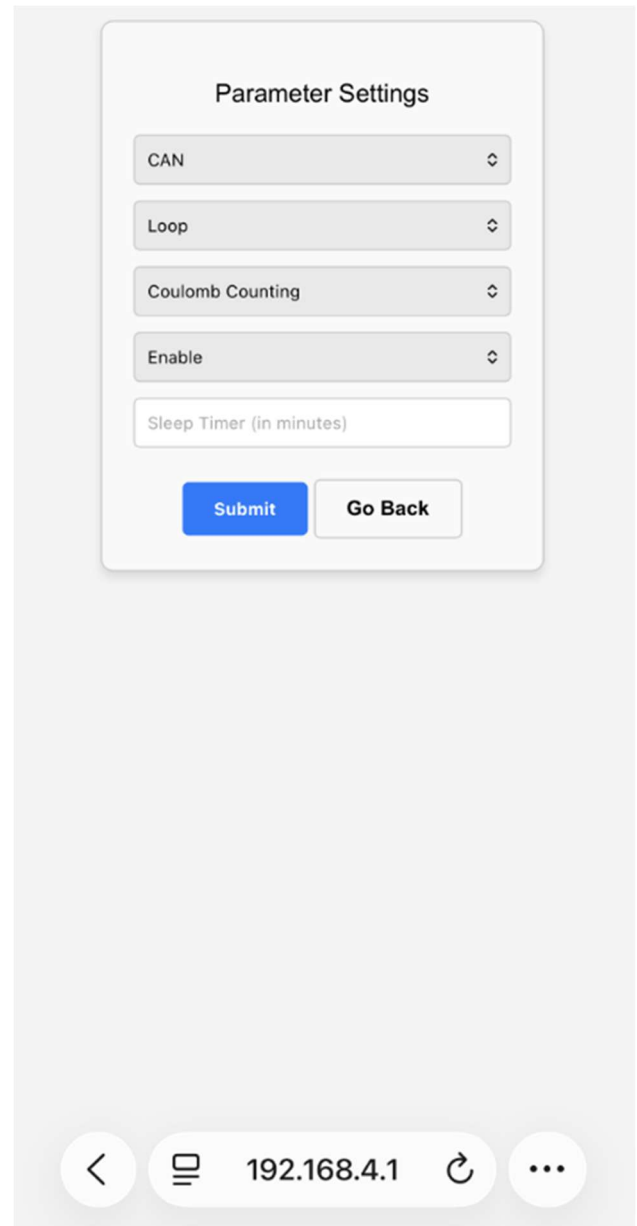

6.3.5. After Submit is pressed, you will get the acknowledge message from the unit.



6.3.6. **Admin Setting:** It is for admin usage only.

Info: Device Info

Device Info shows the parameters set by the app for the unit.

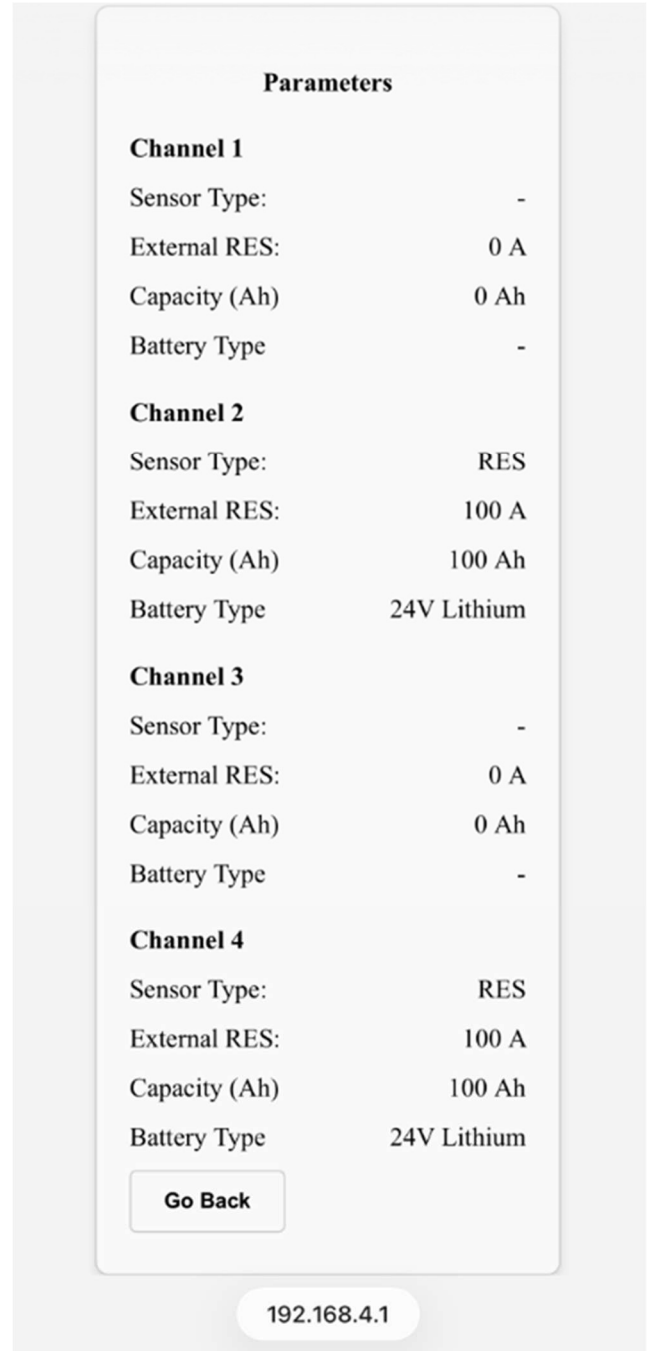

7. Mobile App Setup & Operation

7.1 App Installation

Scan and install the Ultramax SOC Meter App.



Once installed, the home screen will be as below.



7.2 Bluetooth Pairing

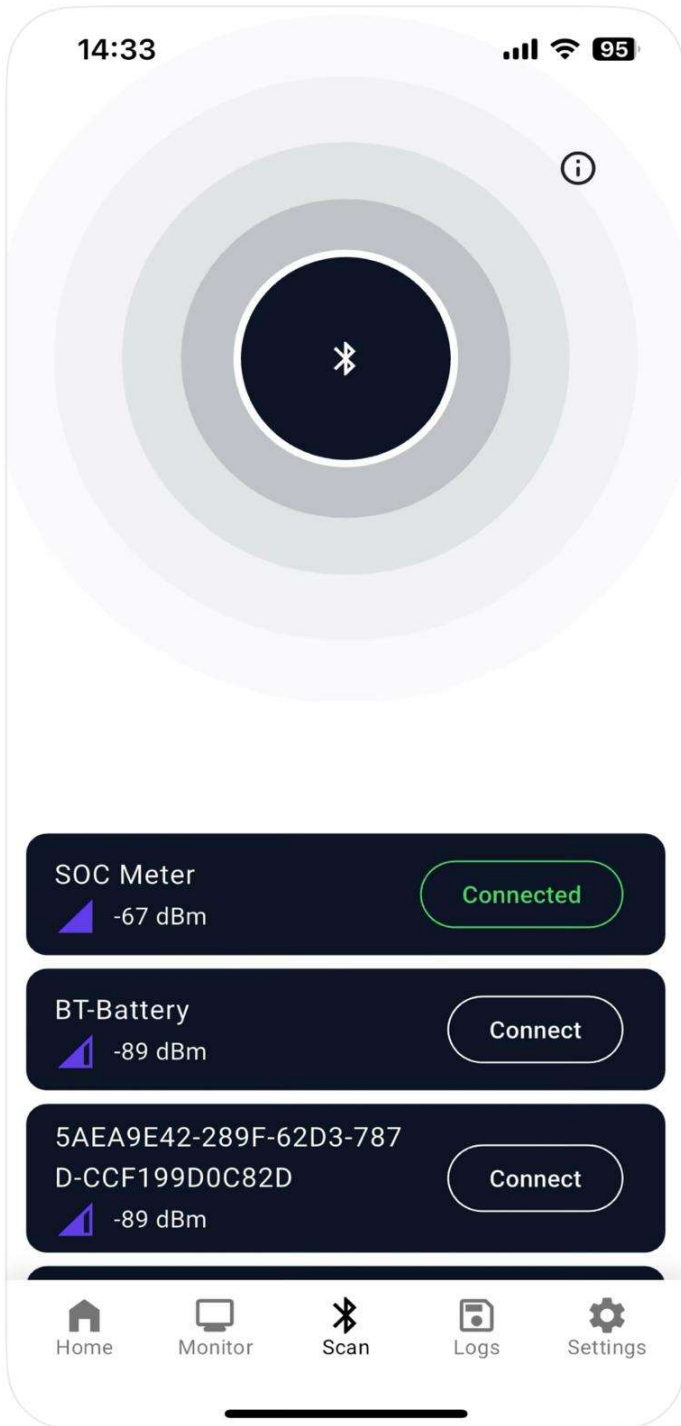

7.3 Monitor / Dashboard Overview

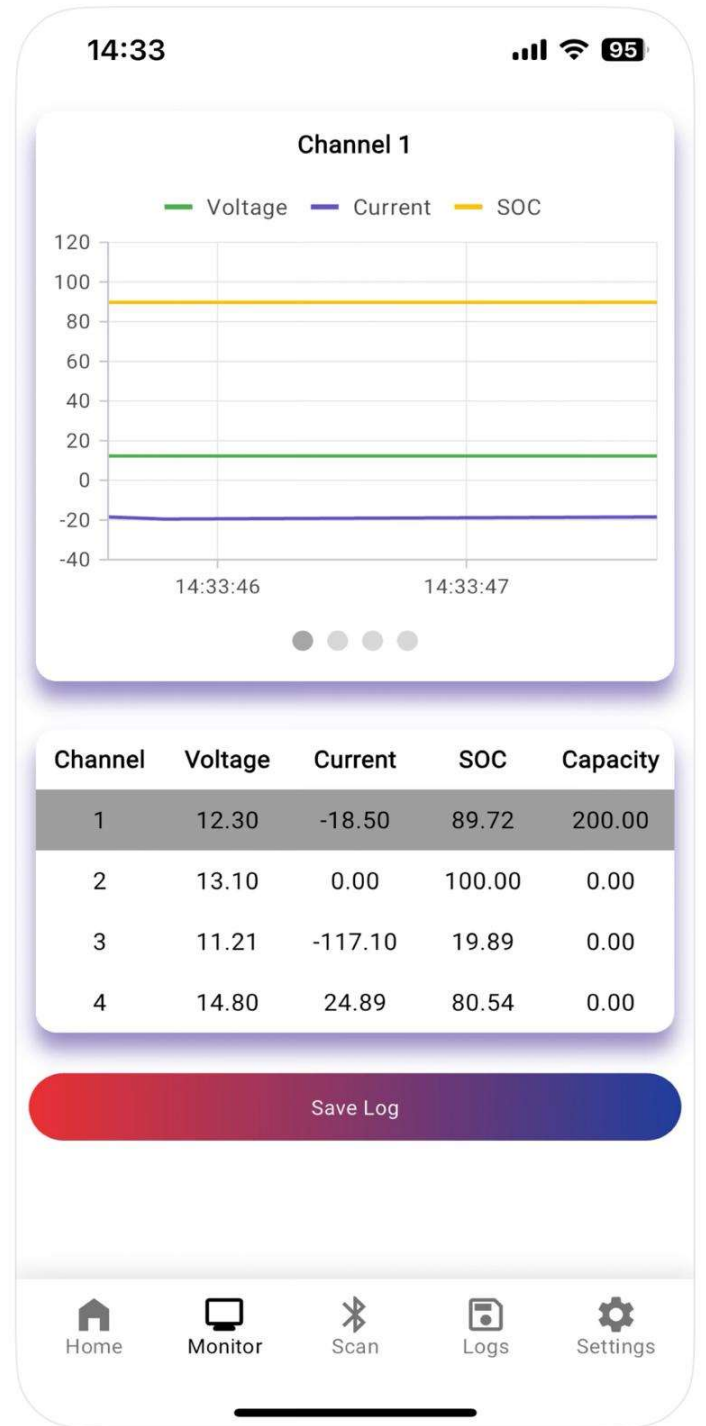

7.4.1 Logs

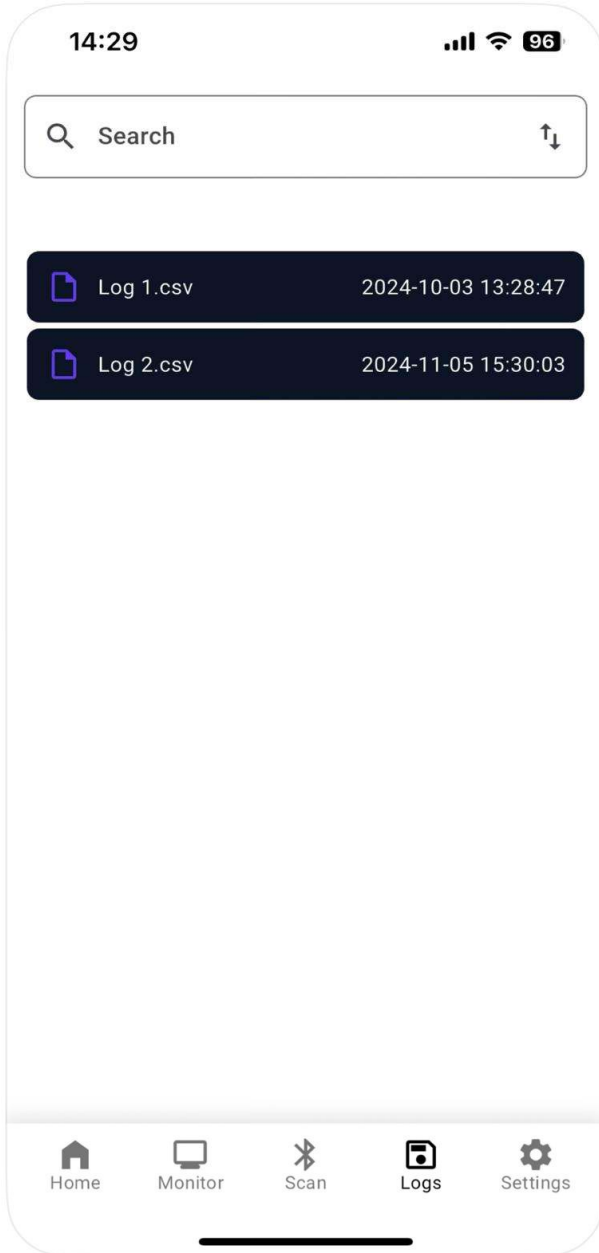

7.4.2 Logs

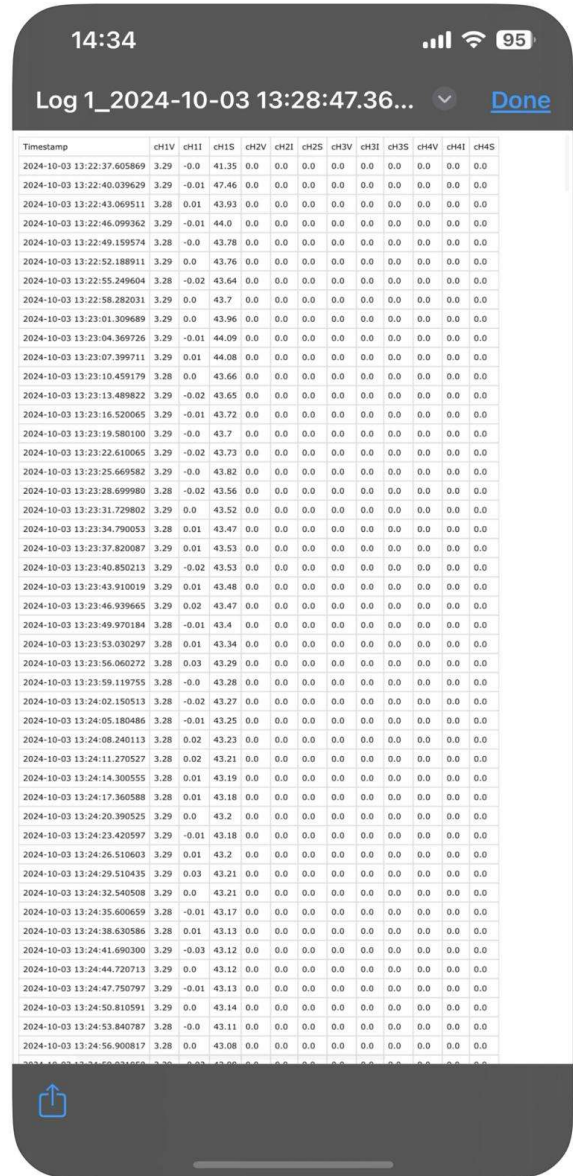

7.5.1 Settings

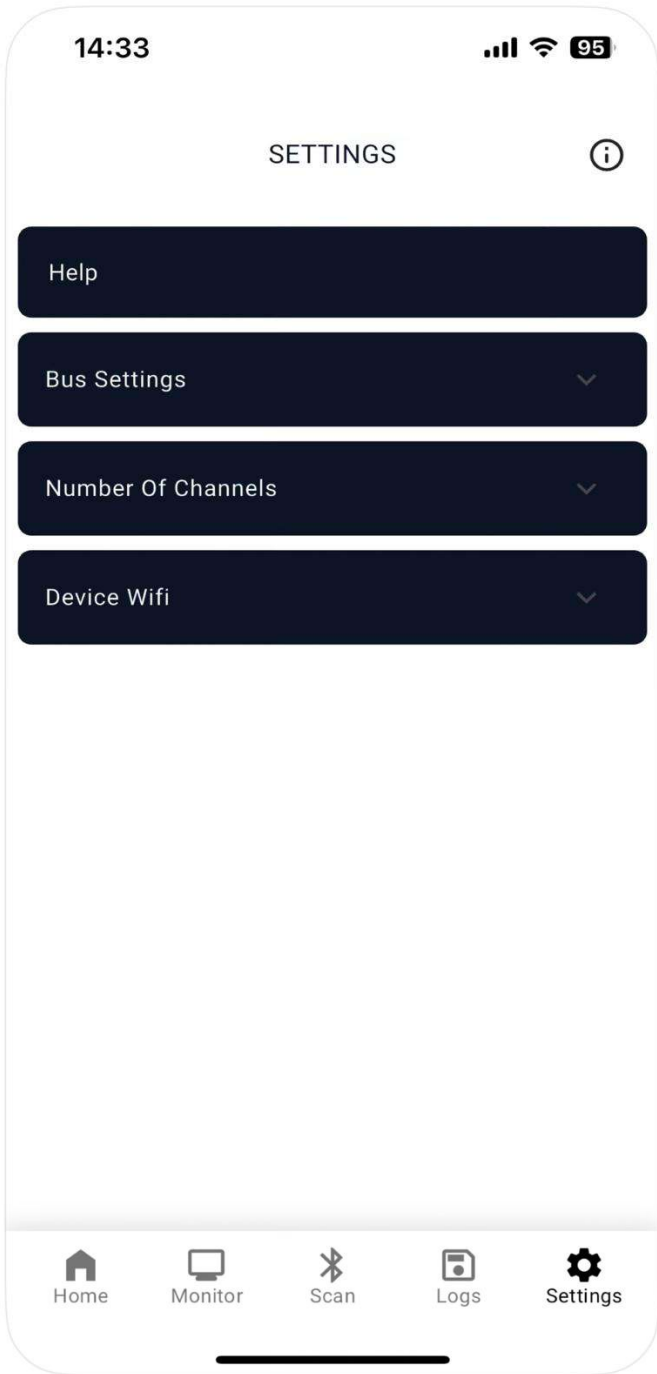

7.5.2

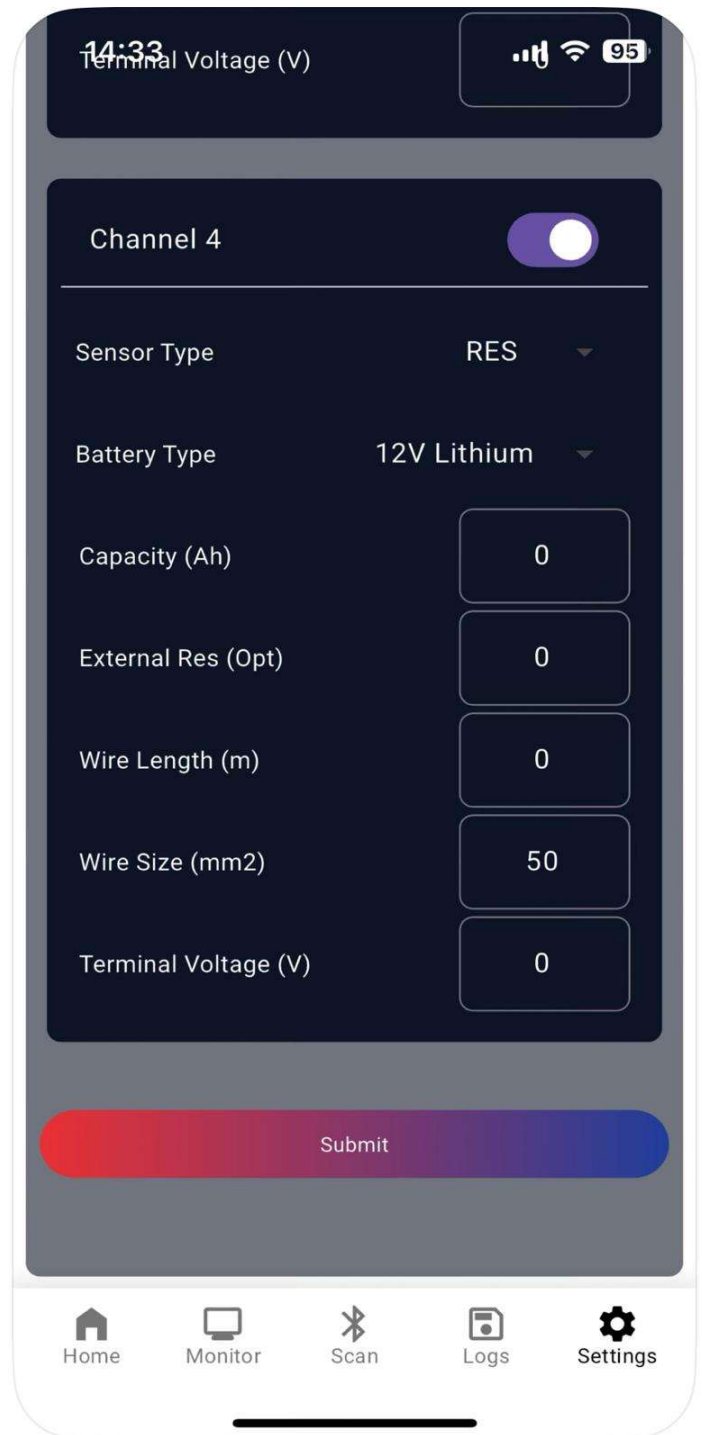

8. Maintenance and Troubleshooting

Inspect wiring, shunts, and connections for looseness or corrosion.

Try the power disconnect and connect soc meter back again for resetting.

9. Safety Information

Follow all relevant safety protocols during installation and operation.

Ensure power is disconnected before maintenance. Use protective gear and observe correct polarity.

10. Warranty and Support

The Ultramax SOC Meter is warranted against manufacturing defects for 12 months from the date of purchase. This warranty excludes damage from misuse or incorrect installation.

Contact Support:

UltraMax Batteries Ltd

Pegamoid Road, London N18 2NG

+44 (0) 208 887 6259

sales@ultramax.co.uk

www.ultramax.co.uk

11. Full scale 2d drawing/ 1:1 ratio (Next Page)

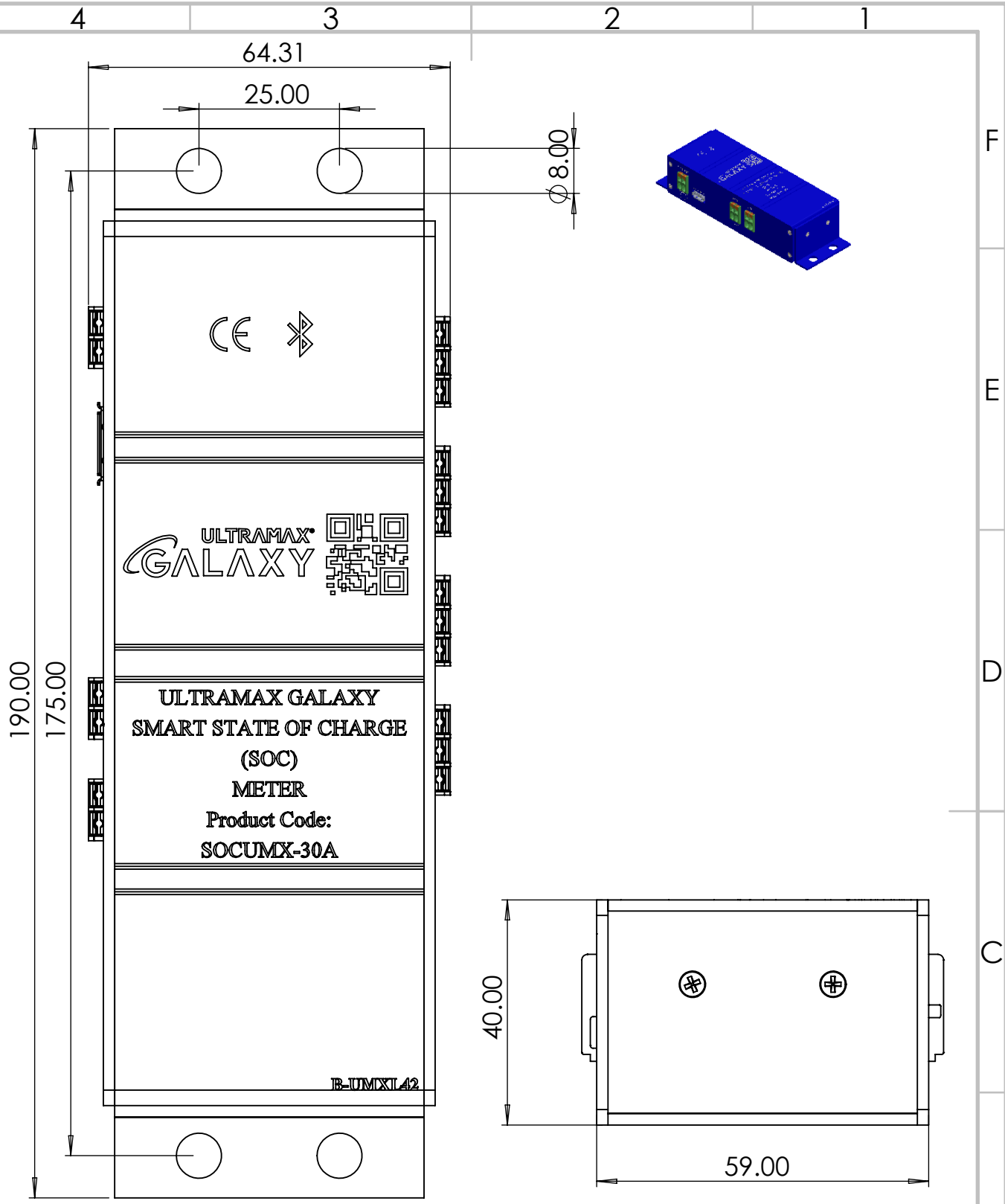

B	UNLESS OTHERWISE SPECIFIED: DIMENSIONS ARE IN MILLIMETERS		FINISH: ANODIZING	DEBURR AND BREAK SHARP EDGES	PART NO: SOCUMX-30A	REVISION
	SURFACE FINISH: $\sqrt{1.6}$ TOLERANCES: ± 0.25 ANGULAR: $\pm 2^\circ$		ULTRAMAX LTD			
A	NAME	DATE			TITLE: GALAXY PRODUCT DRAWING	
	DRAWN	JAYLEN TAN	15 SEP 2025			
	CHK'D	RAMESH	15 SEP 2025			
	APPV'D	EMIL BARUCH	15 SEP 2025			
			MATERIAL: ALUMINIUM	DWG NO. 2D_U01_SOCUMX30ABUMXL42_1-1RATIO	A4	
				SCALE: 1:1	SHEET 1 OF 1	

THIS INFORMATION IS CONFIDENTIAL AND PROPERTY OF ULTRAMAX LTD AND SHALL NOT BE REPRODUCED OR FURTHER DISCLOSED TO ANYONE OTHER THAN ULTRAMAX LTD EMPLOYEE WITHOUT AUTHORIZATION FROM ULTRAMAX LTD.