

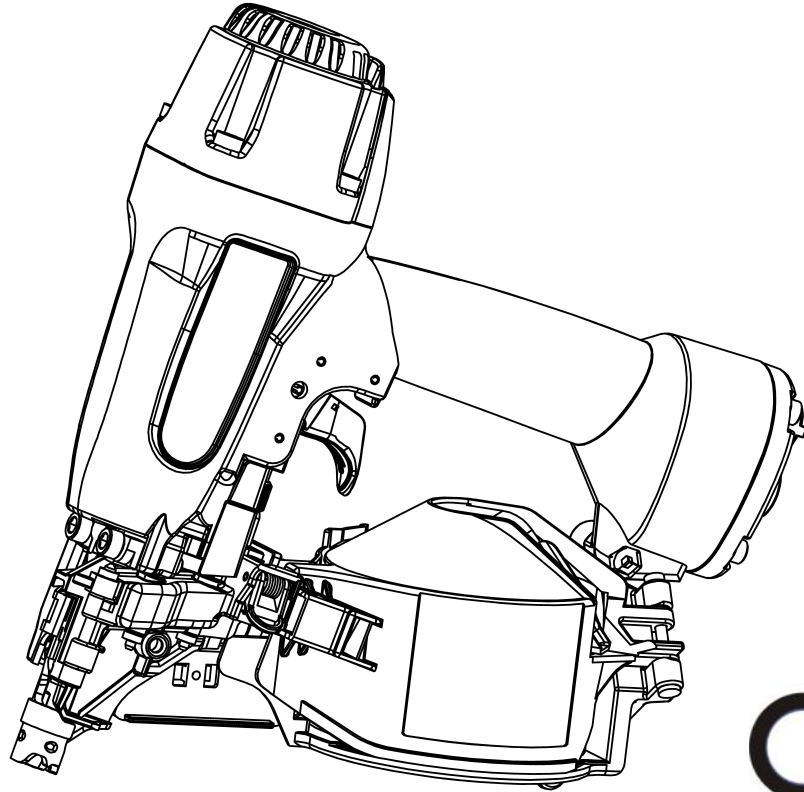

Air Nail Coil Gun - CT4337



Operating Manual



NOTE: Please read and fully understand the instructions in this manual before operating the pneumatic power tool. Carefully read through this OPERATOR'S MANUAL to ensure efficient, safe operation. It is recommended that the Manual be kept readily available as an important reference when using this tool.

IMPORTANT INFORMATION



WARNING: The warnings, cautions and instructions discussed in this instruction manual cannot cover all possible conditions and situations that may occur. It must be understood by the operator that common sense and caution are factors which cannot be built into this product, but must be supplied by the operator.

When using the tool, basic safety precautions should always be followed to reduce the risk of personal injury and damage to equipment.

Read and understand tool labels and operating instructions, safety precautions and warnings in this manual before operating or maintaining this nailer.

Failure to follow warnings could result in **DEATH** or **SERIOUS INJURY**.

Most accidents that result from the operation and maintenance of nailers are caused by the failure to observe basic safety rules or precautions. An accident can often be avoided by recognizing a potentially hazardous situation before it occurs and by observing appropriate safety procedures.

Basic safety precautions are outlined in the "**SAFETY**" section of this manual and in the sections which contain the operation and maintenance instructions. Hazards that must be avoided to prevent bodily injury or tool damage are identified as **DANGERS** or **WARNINGS** on the nailer and in this manual.

Never allow the nailer to be operated by children or individuals who have not reviewed this manual.

OPERATE THE NAILER ACCORDING TO THIS MANUAL.



WARNING!

Always follow the tool manufacturer's safety and maintenance instructions.

Always wear safety glasses with side shields when operating or servicing tools.

Always disconnect the air supply from the tool and empty the magazine when servicing tools.

**SAVE THIS MANUAL
FOR FUTURE REFERENCE!**

WARNING:

The operating instructions shall draw attention to the following

a) Only those fasteners listed in the operating instructions may be used in the fastener driving tools;

NOTE: The fastener driving tool and the fasteners listed in the operating instructions must be seen as one unit system in terms of technical safety.

b) Only the main energy and the lubricants listed in the operating instructions may be used;

c) Fastener driving tools marked with an inverted equilateral triangle standing on one point may only be used with an effective safety yoke;

d) Fastener driving tools equipped with contact actuation or continuous contact actuation, marked with the symbol "Do not use on scaffoldings, ladders", shall not be used for specific application for example:

when changing one driving location to another involves the use of scaffoldings, stairs, ladders, or ladder alike constructions, e.g. roof laths, closing boxes or crates, fitting transportation safety systems e.g. on vehicles and wagons;

e) For the maintenance of fastener driving tools, only spare parts specified by the manufacturer or his authorized representative shall be used;

f) Repairs shall be carried out only by agents authorized by the manufacturer or by other specialists, having due regard to the information given in the operating instructions;

NOTE: Specialists are those who, as a result of professional training or experience, have sufficient expertise in the field of fastener driving tools and sufficient familiarity with relevant governmental industrial protection provisions, accident prevention regulations, directives and generally recognized technical regulations (e.g. CEN- and CENELEC-standards), to be able to assess the safe working condition of fastener driving tools.

g) Stands for mounting the fastener driving tools to a support for example a work table, shall be designed and constructed by the stand manufacturer, in such a way that the fastener driving tool can be safely fixed for the intended use, thus for example avoiding damage, distortion or displacement.

Additional instructions for fastener driving tools operated by compressed air

a) Fastener driving tools operated by compressed air shall only be connected to compressed air lines where the maximum allowable pressure cannot be exceeded by a factor of more than 10%, which can for example be achieved by a pressure reduction valve which includes a downstream safety valve;

b) When using fastener driving tools operated by compressed air, particular attention must be paid to avoid exceeding the maximum allowable pressure;

c) Fastener driving tools operated by compressed air should only be operated at the lowest pressure required for the work process at hand, in order to prevent unnecessarily high noise levels, increased wear and resulting failures;

d) Hazards caused by fire and explosion when using oxygen or combustible gases for operating compressed air operated fastener driving tools.

SAFETY INFORMATION



WARNING:

BEFORE USING THE TOOL, READ CAREFULLY AND UNDERSTAND THE FOLLOWING SAFETY INSTRUCTIONS. FAILURE TO FOLLOW WARNING COULD RESULT IN DEATH OR SERIOUS INJURY.



1. WEAR SAFETY GLASSES OR GOGGLES.

Danger to the eyes always exists due to the possibility of dust being blown up by the exhausted air or of a fastener flying up due to the improper handling of the tool. For these reasons, safety glasses or goggles shall always be worn when operating the tool. The employer and/or user must ensure that proper eye protection is worn. The employer is responsible to enforce the use of eye protection equipment by the tool operator and all other personnel in the work area. NOTE: Non-side shielded spectacles and face shields alone do not provide adequate protection.



2. EAR PROTECTION MAY BE REQUIRED IN SOME ENVIRONMENTS.

As the working condition may include exposure to high noise levels which can lead to hearing damage, the employer and user should ensure that any necessary hearing protection is provided and used by the operator and others in the work area.



3. DO NOT USE ANY POWER SOURCE EXCEPT AN AIR COMPRESSOR.

The tool is designed to operate on compressed air. Do not operate the tool on any other high pressure gas, combustible gases (e.g. Oxygen, acetylene, etc.) since there is the danger of an explosion. For this reason, absolutely so not use anything other than an air compressor to operate the tool.

4. OPERATE WITHIN THE PROPER AIR PRESSURE RANGE.

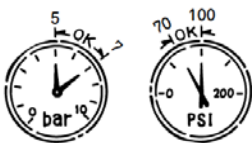

The tool is designed to operate within an air pressure range of 70 psi to 100 psi (5 to 7 bar). The pressure should be adjusted to the type of the work being fastened. The tool shall never be operated when the operating pressure exceeds 120 psi. (8.3 bar).



5. DO NOT OPERATE THE TOOL NEAR A FLAMMABLE SUBSTANCE.

Never operate the tool near a flammable substance (e.g., thinner, gasoline, etc.). Volatile fumes from these substances could be drawn into the compressor and compressed together with the air and this could result in an explosion.

6. DO NOT USE A WRONG FITTING.

The connector on the tool must not hold pressure when air supply is disconnected. If a wrong fitting is used, the tool can remain charged with air after disconnecting and thus will be able to drive a fastener even after the line of air is disconnected, possibly causing injury.

7. DISCONNECT THE AIR SUPPLY AND EMPTY THE MAGAZINE WHEN THE TOOL IS NOT IN USE.

Always disconnect the air supply from the tool and empty the magazine when operation has been completed or suspended, when unattended, moving to a different work area, adjusting, disassembling, or repairing the tool, and when clearing a jammed fastener.

8. INSPECT SCREW TIGHTNESS.

Loose or improperly installed screws or bolts cause accidents and tool damage when the tool is put into operation. Inspect to confirm that all screws and bolts are tight and properly installed prior to operating the tool.

9. DO NOT TOUCH THE TRIGGER UNLESS YOU INTEND TO DRIVE A FASTENER.

Whenever the air supply is connected to the tool, never touch the trigger unless you intend to drive a fastener into the work. It is dangerous to walk around carrying the tool with the trigger pulled, and this and similar actions should be avoided.

10. NEVER POINT THE DISCHARGE OUTLET TOWARD YOURSELF AND PERSONNEL.

If the discharge outlet is pointed toward people, serious accidents may be caused when misfiring. Be sure the discharge outlet is not pointed toward people when connecting and disconnecting the hose. Loading and not loading the fasteners or similar operations.

11. USE SPECIFIED FASTENERS.

The use of fasteners other than specified fasteners will cause the tool malfunction. Be sure to use only specified fasteners when operating the tool.

12. PLACE THE DISCHARGE OUTLET TO THE WORK PROPERLY.

Failure to place the discharge outlet of the nose in a proper manner can result in a fastener flying up and is extremely dangerous.

13. KEEP HANDS AND BODY AWAY FROM THE DISCHARGE OUTLET

When loading and using the tool, never place a hand or any part of body in fastener discharge area of the tool. It is very dangerous to hit the hands or body by mistake.

14. DO NOT DRIVE FASTENERS CLOSE TO THE EDGE AND CORNER OF THE WORK AND THIN MATERIAL

The work piece is likely to split and the fastener could fly and hit someone.

15. DO NOT DRIVE FASTENERS ON THE TOP OF OTHER FASTENERS.

Driving fasteners on the top of other fasteners may cause deflection fasteners which could cause injury.

16. REMOVING THE FASTENERS AFTER COMPLETING OPERATION

If fasteners are left in the magazine after the completion of operation, there is the danger of a serious accident occurring prior to the resumption of operation, should the tool be handled carelessly, or when connecting the air removes all fitting. For this reason, always move the fasteners away which remaining in the magazine after completion of the operation.

17. CHECK OPERATION OF THE CONTACT TRIP MECHANISM FREQUENTLY IN CASE OF USING A CONTACT TRIP TYPE TOOL

Do not use the tool if the trip is not working correctly as accidental driving of a fastener may result. Do not interfere with the proper operation of the contact trip mechanism.

18. WHEN USING THE TOOL OUTSIDE OR ELEVATED PLACE.

When fastening roofs or similar slanted surface, start fastening at the lower part and gradually work your way up. Fastening backward is dangerous as you may lose your foot place. Secure the hose at a point close to the area you are going to driver fasteners. Accidents may be caused due to the hose being pulled inadvertently or getting caught.

19. NEVER USE THE TOOL IF ANY PORTION OF THE TOOL CONTROLS (e.g., TRIGGER, CONTACT ARM) IS INOPERABLE DISCONNECTED, ALTERED OR NOT WORKING PROPERLY.

20. NEVER ACTUATE THE TOOL INTO FREE SPACE.

This will avoid any hazard caused by free flying fasteners and excessive strain of the tool.

21. ALWAYS ASSUME THAT THE TOOL CONTAINS FASTENERS.

22. DO NOT USE ON SCAFFOLDINGS LADDERS.



The tool shall not be used for specific application for example:

- When changing one driving location to another involves the use of scaffoldings, stairs, ladders, or
- Ladder alike constructions, e.g. roof laths,
- Closing boxes or crates,
- Fitting transportation safety systems e.g. on vehicles and wagons.

TECHNICAL DATA

Type of tool	CN45 Construction Coil Nailer
Dimensions	11-1/8"X4-1/4"X10-1/8" 248mmX108mmX260mm
Weight (without fasteners)	1.60kgs (3.50lbs.)
Actuation mode	Contact/Single-sequential actuation
Magazine capacity	400 nails (conical wire welded nails) 200 nails (plastic sheet collated nails)
Maximum allowable pressure	120psi (8.3bar)
Recommended pressure range	70psi to 100psi (5bar to 7bar)

Fasteners

Only the nail sizes shown in the table below can be driven with this nailer.

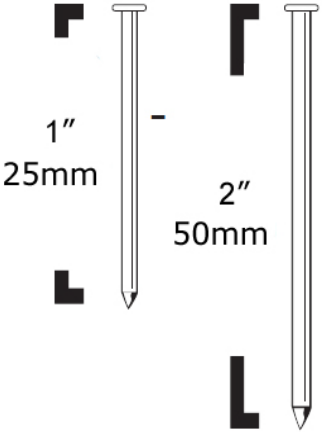
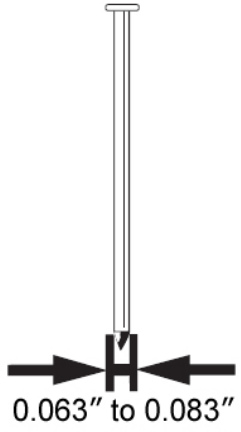
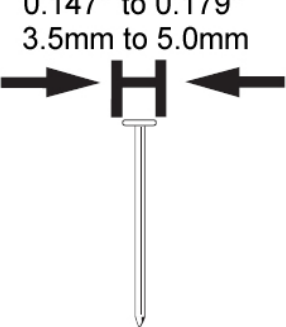
15° Conical wire welded coil nails & flat plastic sheet collated nails		
Nail Length	Shank Diameter	Head Diameter
 <p>1" 25mm</p> <p>2" 50mm</p>	 <p>0.063" to 0.083" 1.59mm to 2.1mm</p>	 <p>0.147" to 0.179" 3.5mm to 5.0mm</p>

Applications

- Sub-flooring;
- Fencing;
- Wall sheathing and roof sheathing;
- Fastening gypsum board, decorative board and other interior boards.

NAILER CONNECTION AND OPERATION

NOTE: The information contained in this manual is designed to assist you in the safe operation of the nailer. Some illustrations in this Manual may show details or attachments that are different from those on your nailer.

Air Supply, Connections and Operating Pressure

Read section titled **SAFETY**. Make sure of the following before operation: **Air Supply Power Source (Compressor)**

- Use only clean, dry, regulated compressed air as a power source for this nailer.
- **NEVER** use oxygen or other bottled gases, as an explosion may occur.
- Use suitable air compressors used to supply compressed air to this nailer
- Moisture or oil in the air compressor may accelerate wear and corrosion in the nailer.
- Drain daily.

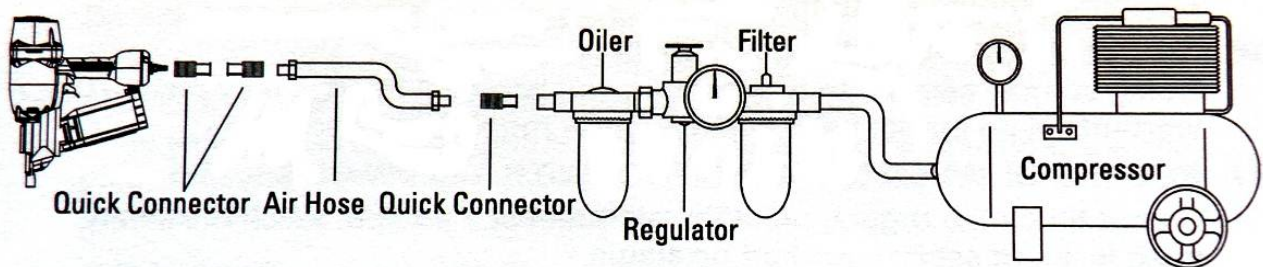

Connections

1. Fittings

Install a female coupler to the hose. The female coupler will connect to the quick release that fits the tool.

2. Filter-Regulator-Lubricator

- **NEVER** connect nailer to pressure which potentially exceeds 120psi.
- Filter-regulator-lubricator units supply an optimum condition for the nailer and extend the nailer life. These units should always be used.

Filter

- The filter removes moisture and dirt mixed in compressed air.
- Keep the filter clean by maintaining tool regularly.
- Drain daily.

Regulator

- The regulator controls the operating pressure for safe operation of the nailer.
- Inspect the regulator before operation to be sure it operates properly.

Nailer Connection and Operation

Lubricator

- The lubricator supplies and oil mist to the nailer.
- Inspect the lubricator before operation to be sure the supply of lubricant is adequate.
- If an inline lubricator is not used, a few drops of oil will need to be added to the nailer inlet before each use.

3. Air Hose

Air hose must have a minimum working pressure rating of 180 psi.

Hose has a min. ID of 1/4"(ISO 7-1) and max. length of no more than 17'(5 meter).

The supply hose should contain a fitting that will provide "quick disconnecting" from the male plug on the tool.

Operating Pressure

- Recommended operating pressure range is 70 to 100 psi.
- Maximum permissible operating pressure is 120 psi.
- Select the operating pressure within this range for the best fastener performance. The nail length and thickness and the hardness of the wood are factors in determining what the pressure should be set at.
- Do not exceed this recommended operating pressure.

NOTE: Dirt and water in the air supply are major causes of wear in the tool.

An air filter will help to get the best performance and minimum wear from the tool. Frequent, but not excessive, lubrication is required for the best performance. Oil added through the air line connection will lubricate the internal parts.

WARNING



NEVER connect nailer to pressure which potentially exceed 120psi.

DO NOT USE THE WRONG FITTING ON NAILER.

The nailer and air hose must have a hose coupler so that all pressure is removed from the nailer when the coupler is disconnected. The connector on the tool must not hold pressure when the air supply is disconnected. If the wrong fitting is used, the tool can remain charged with air after disconnecting and thus will be able to drive a nail even after the air line is disconnected, possibly causing injury.

DANGER



NEVER use oxygen or other bottled gases, as an explosion may occur.

INSTRUCTION FOR OPERATION

1. Before operation

- (1) Wear safety glasses or goggles
- (2) Do not connect the air supply
- (3) Inspect screw tightness
- (4) Check operation of the contact arm & trigger if moving smoothly
- (5) Connect the air supply
- (6) Check the air-leakage.(the tool must not have the air-leakage.)
- (7) Hold the tool with finger-off the trigger, then push the contact arm against the work-pieces.(the tool must not operate.)
- (8) Hold the tool with contact arm free from work-piece and pull the trigger.(the tool must not operate.)

2. Operation

Keep hands and body away from the discharge outlet when driving the fasteners because of dangerous of hitting the hands or body by mistake.

Nail loading

- (1) Disconnect the air hose.
- (2) Press LATCH (210470) to open DOOR (210490), then open MAGAZINE COVER (421060).
- (3) Adjust the height of NAIL SUPPORT (421040) according to nails length.
- (4) Fix the first nail in the groove on FEED PAWL (210510).
- (5) Close MAGAZINE COVER (421060), close DOOR (210490).
- (6) Connect the air hose.

Test operation

- (1) Adjust the air pressure at 70psi. (5 bar) and connect the air supply.
- (2) Without touching the trigger, depress the contact arm against the work-piece. Pull the trigger.(the tool must fire the fastener.)
- (3) With the tool off the work-piece, pull the trigger. Then depress the contact arm against the work-piece.(the tool must fire the fastener.)
- (4) Adjust the air pressure as much as the lowest possible according to the diameters and length of fastener and the hardness of work-piece.

MAINTENANCE AND INSPECTION

Read the section title SAFETY.

SERVICE AND REPAIRS

All quality tools will eventually require servicing or replacement of parts due to wear from normal use. It is recommended that these operations should be performed by a professional technician.

NOTE: The information contained in this Manual is designed to assist you in the safe maintenance of the nailer. Some illustrations in this Manual may show details or attachments that are different from those on your nailer.

WARNING: Disconnect air hose and remove nails from nailer when:

- Doing maintenance and inspection
- Cleaning a jam

Inspecting the magazine

1. DISCONNECT AIR HOSE.
2. Clean the magazine. Remove dust which may have accumulated in the magazine.
3. Lubricate the nailer rail with nailer lubricant.

Clearing a jam

Remove a jammed nail in the following order:

1. DISCONNECT AIR HOSE.
2. Remove all nails.
3. Remove the jammed nail with a slotted head screwdriver.
4. In case of frequent jams, contact an authorized service center.

A qualified person should perform repair and maintenance

Periodic maintenance to be performed:

- Check that the piston bumper is operating normally. A damaged piston bumper may cause damages to other component parts.
- Check o-rings for wear or damage. Damaged o-rings may affect overall performance.
- Make sure all screws are secure. Loose screws may affect overall performance.
- When repairing a tool, make sure the internal parts are clean and lubricated.

Storing

- When not in use of an extended period, apply a thin coat of the lubricant to the steel parts to avoid rust.
- The nailer should be stored in a warm and dry place when not in use. Do not store the nailer in a cold weather environment.

PARTS LIST

NO.	CODE	Description	NO.	CODE	Description
1	610560	BOLT M6X20 (Loctite)	55	320110	TRIGGER STEM
2	321600	BUSHING	56	510030	O-RING 2.5X1.4
3	410490	EXHAUST COVER	57	620050	TRIGGER VALVE SPRING
4	321590	EXHAUST FILTER (A)	58	510240	O-RING 8.6X1.9
5	321580	EXHAUST FILTER (B)	59	330010	TRIGGER VALVE BUSHING
6	610120	BOLT M5X25	60	510180	O-RING 5.8X1.9
7	110380	CYLINDER CAP	61	420160	PIN CAP (B)
8	520240	GASKET	62	321640	STEP PIN
9	410480	BACK BUMPER	63	620730	FEED SPRING
10	421000	EXHAUST SEAL	64	321630	CHECK TOE
11	620690	COMPRESSION SPRING	65	420170	PIN CAP (A)
12	420990	HEAD VALVE PISTON	66	210510	FEED PAWL
13	510550	O-RING 40X2.65	67	620720	SPRING
14	410470	BUMPER	68	321620	FEED PAWL PIN
15	510690	O-RING 51.5X2.65	69	321610	DOOR PIN
16	420980	CYLINDER RING	70	210500	NOSE
17	510540	O-RING 38.7X3.55	71	210490	DOOR
18	310330	CYLINDER	72	322170	CHECK PAWL PIN
19	510530	O-RING 38.7X2.65	73	210480	CHECK PAWL
20	420970	CYLINDER COLLAR	74	620710	CHECK PAWL SPRING
21	110370	BODY	75	421010	GUARD COVER
22	410460	HANDLE GRIP	76	640130	ROLL PIN 3X20
23	323220	DOWEL PN	77	210470	LATCH
24	420590	TRIGGER BRACKET	78	620700	LATCH SPRING
25	620370	SPRING	79	510260	O-RING 9X1.8
26	110190	ADJUSTER BUTTON	80	321720	FEED PISTON
27	320880	CONTACT PLATE	81	510390	O-RING 17X2.65
28	420580	TRIGGER	82	620120	FEED PISTON SPRING
29	640180	ROLL PIN 3X30	83	410240	FEED PISTON BUMPER
30	420950	PIN CAP	84	320760	FEED PISTON CAP
31	323170	STEP PIN	85	630080	SNAP RING
32	510950	O-RING 3.55X1.8	86	520250	END CAP SEAL
33	610210	BOLT M6X22 (Loctite)	87	110390	END CAP
34	321550	SAFETY UPPER	88	610110	BOLT M5X22
35	620670	SPRING	89	421060	MAGAZINE COVER
36	420930	SAFETY UPPER GUIDE	90	420520	SPRING HOLDER (A)
38	420920	ADJUSTER DIAL	91	620750	MAGAZINE SPRING
39	420910	SAFETY GUIDE	92	421040	NAIL SUPPORT PLATE
40	321680	ADJUSTER	93	420240	SPRING HOLDER (B)
41	510140	O-RING 5.15X1.8	94	421030	MAGAZINE
42	620910	SNAP RING 4	95	610140	BOLT M5X35
44	321660	SAFETY	96	610320	NUT M5 (Nylock)
46	321650	DIRVER BLADE	97	321690	MAGAZINE PIN
47	310340	PISTON	98	410290	NOSE CAP
48	510480	O-RING 30X3.55	100	510310	O-RING 10X1.8
49	620740	SPRING	101	510210	O-RING 6.3X1.8
50	640250	STRAIGHT PIN B3X15	102	#####	NOT APPLICABLE
51	421820	TRIGGER VALVE CAGE	103	#####	NOT APPLICABLE
52	510410	O-RING 18.3X2.65	104	420640	PIN CAP C
53	511240	O-RING 11.8X2.65	P1	D321651	DRIVER UNIT
54	420080	TRIGGER VALVE CAP	P2	T421821	TRIGGER VALVE

TOOL SCHEMATIC-CN45

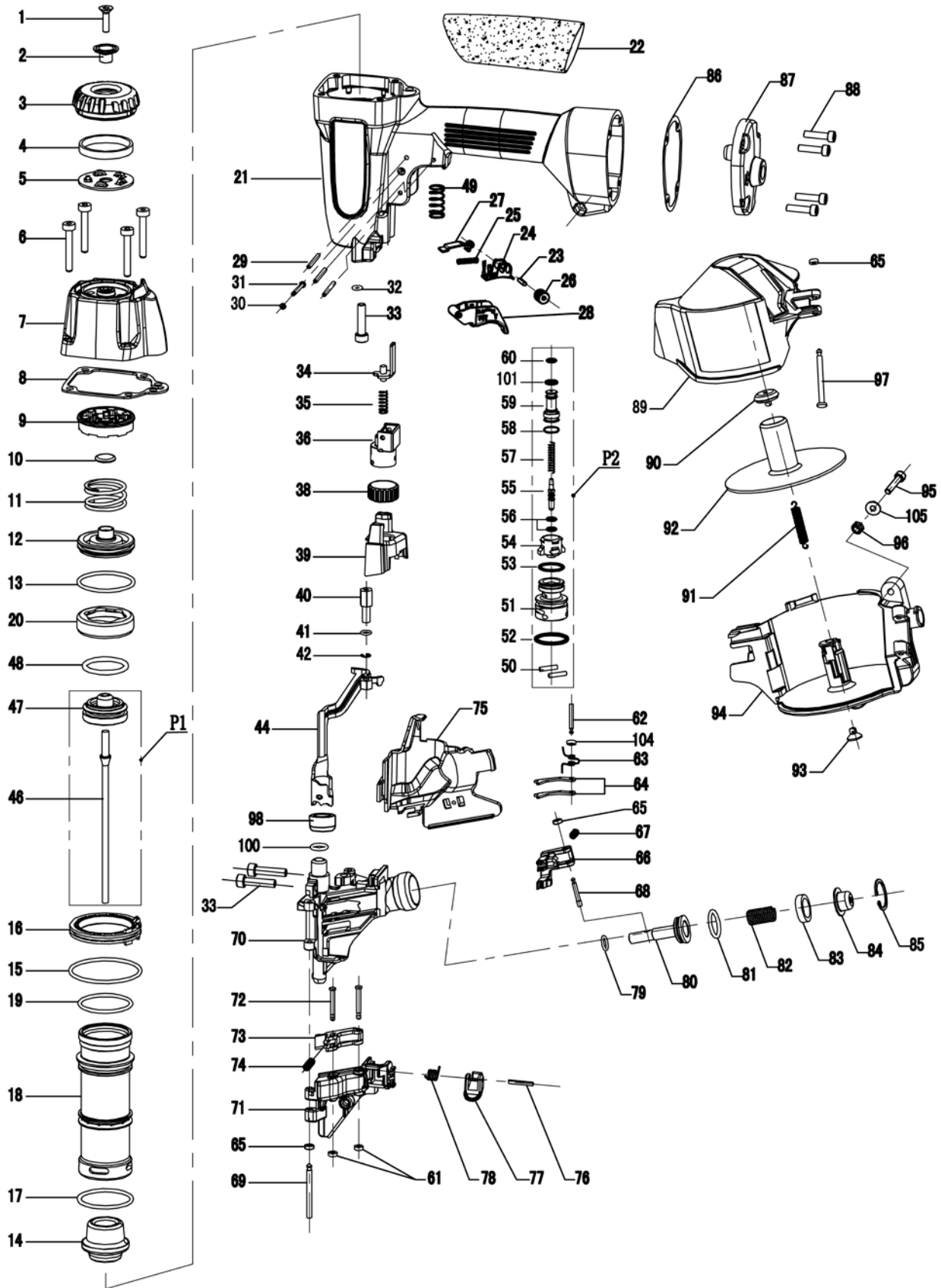

CANNON TOOLS LTD
Add: 20 station road, Rowley Regis, west midlands, B65 0JU.U.K.
Made in China