

GLOBAL PROCUREMENT AND MARKETING LIMITED

3X3M FOLDING GAZEBO

Assembly Instructions Please keep for future reference

GAZESY3BL

GAZESY3BK

GAZESY3GR

GAZESY3GY

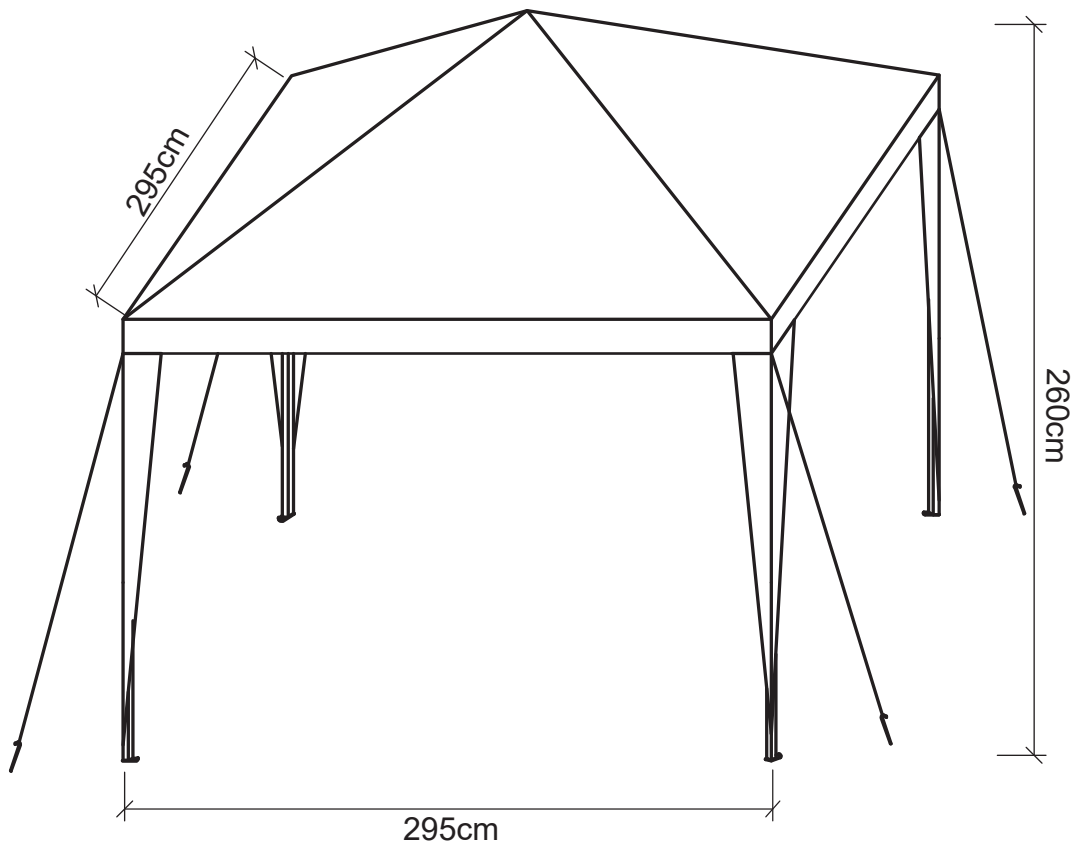

Dimensions	No. people	Assembly Time	OW #
Length: 295cm Width: 295cm Height: 260 cm		20 mins (approx.)	DP005BL DP005BK DP005GN DP005GY

thank you

For purchasing this

GPM Limited

product

Important

- PLEASE READ THESE INSTRUCTIONS FULLY BEFORE STARTING ASSEMBLY
- PLEASE DO NOT THROW THE PACKAGING AWAY UNTIL YOU ARE SATISFIED WITH PURCHASE, GOODS NEED TO BE RETURNED IN ORIGINAL PACKAGING.

If you need help or have damaged or missing parts, please email aftersales@gpmfurniture.co.uk

Safety and Care Advice

Important

- PLEASE READ THESE INSTRUCTIONS FULLY BEFORE STARTING ASSEMBLY
- PLEASE DO NOT THROW THE PACKAGING AWAY UNTIL YOU ARE SATISFIED WITH PURCHASE, GOODS NEED TO BE RETURNED IN ORIGINAL PACKAGING.

- Check you have all the components and tools listed on pages 3 and 4.
- Remove all fittings from the plastic bags and separate them into their groups.
- Keep children and animals away from the work area, small parts could choke if swallowed.
- Make sure you have enough space to lay out the parts before starting.
- Do not stand or put weight on the product, this could cause damage.
- Assemble the item as close to its final position (in the same room) as possible.
- Assemble on a soft, level surface to avoid damaging the unit or your floor.
 - Dispose of all packaging carefully and responsibly.



Care and Maintenance

- Only clean using a damp cloth and mild detergent, do not use bleach or abrasive cleaners.
- From time to time check that there are no loose screws on this unit.
- This product should not be discarded with household waste. Take to your local authority waste disposal centre.

If kept outside please ensure in the winter months that the product is correctly covered or put away into a dry environment to prevent corrosion, weathering or damage.

If your product is not designed to be outside, we recommend that it is always kept indoors in a dry environment.

If you are unhappy with the product and wish to return it, please follow the retailer's returns procedure.

Components - Panels

If you have damaged or missing components,
email: aftersales@gpmfurniture.co.uk

Please check that you have all the components listed below before constructing your item.





Part No	Description	Qty
1	Roof cloth	1
2	Folding shelf	1
3	Ground nails	8
4	Ropes	4
5	Carry bag	1

Components - Fixings

If you have damaged or missing components,
email: aftersales@gpmfurniture.co.uk

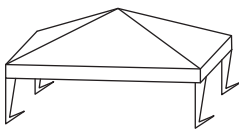
Please check that you have all the components listed below before constructing your item.

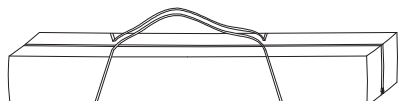
Note: The quantities below are the correct amount to complete the assembly. In some cases more fittings may be supplied than are required.

(A)		(B)		(C)	
(E)		(F)		(G)	

Important – Please read these instructions fully before starting assembly

If you need help or have damaged or missing parts, please email aftersales@gpmfurniture.co.uk

Assembly Instructions

If you have damaged or missing components,
email: aftersales@gpmfurniture.co.uk

Step 1

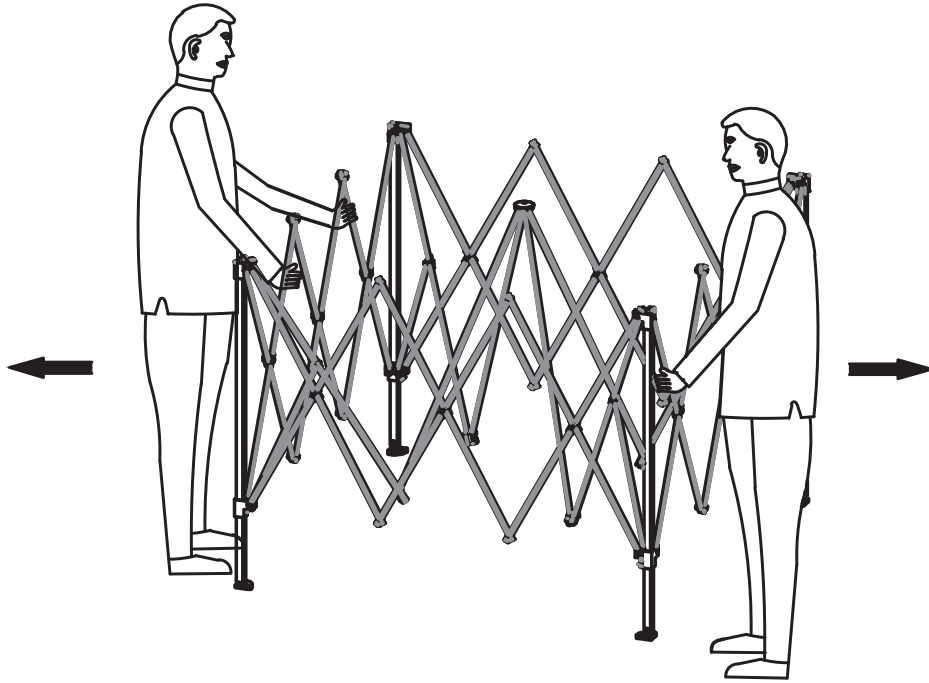

Step 2

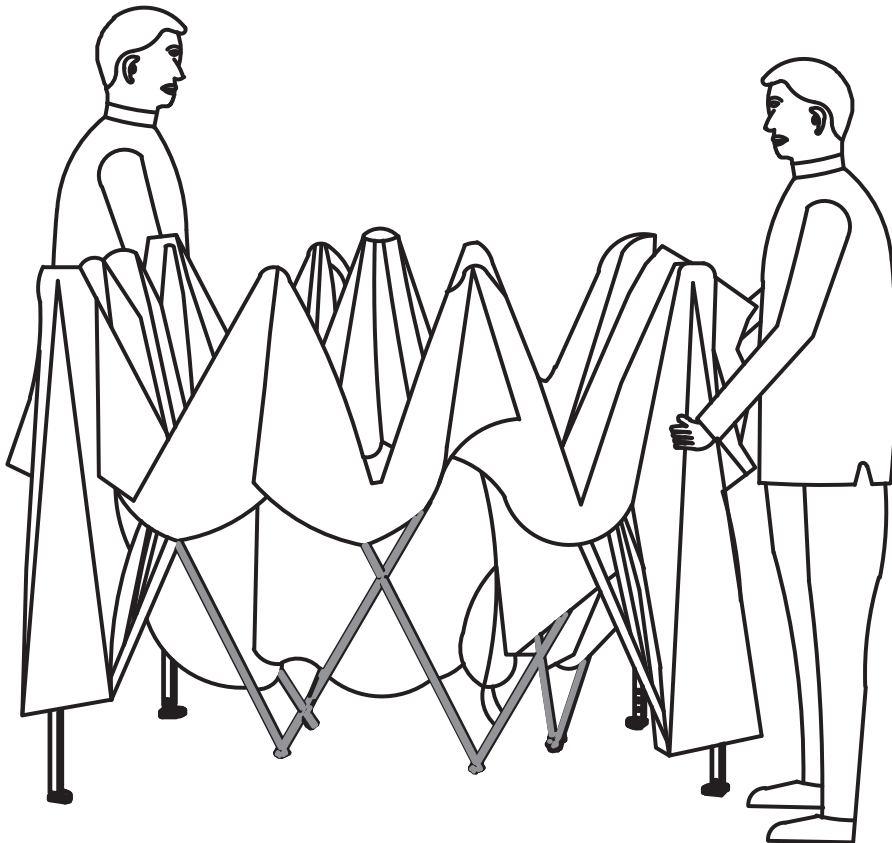

Step 3

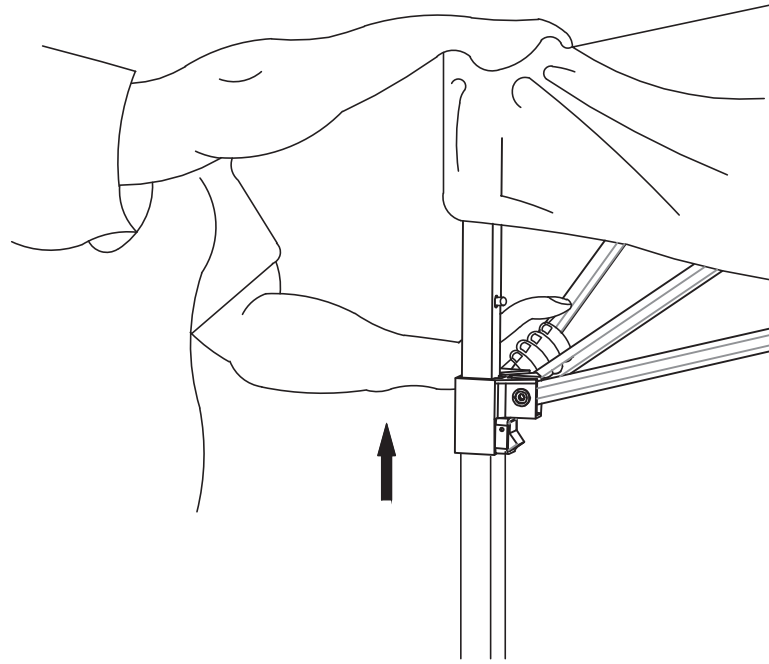

Step 4

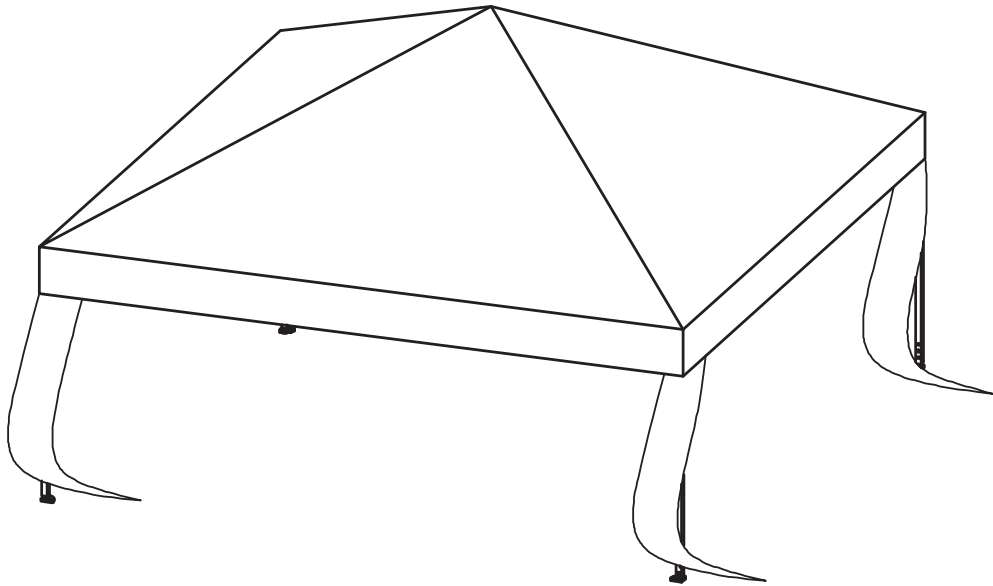

Step 5

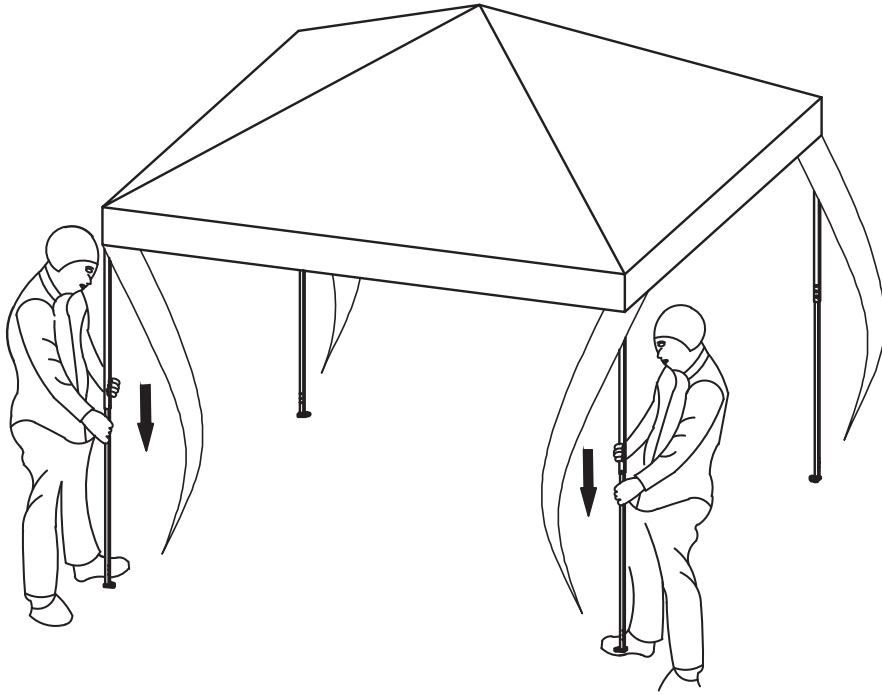

Step 6

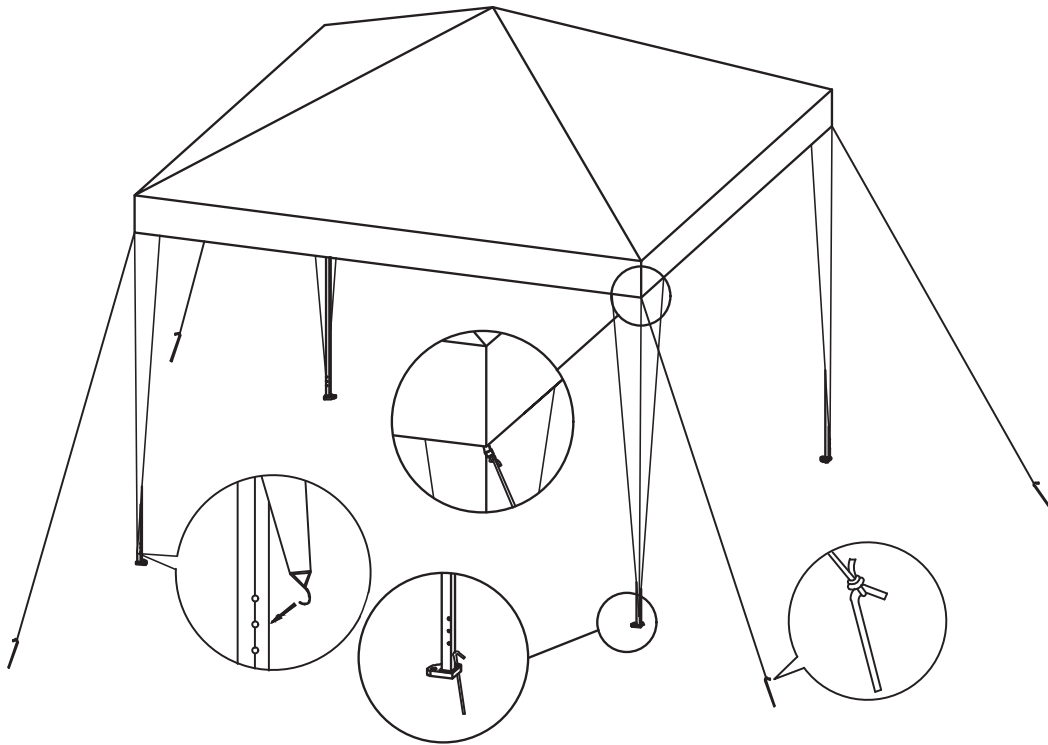

Step 7:

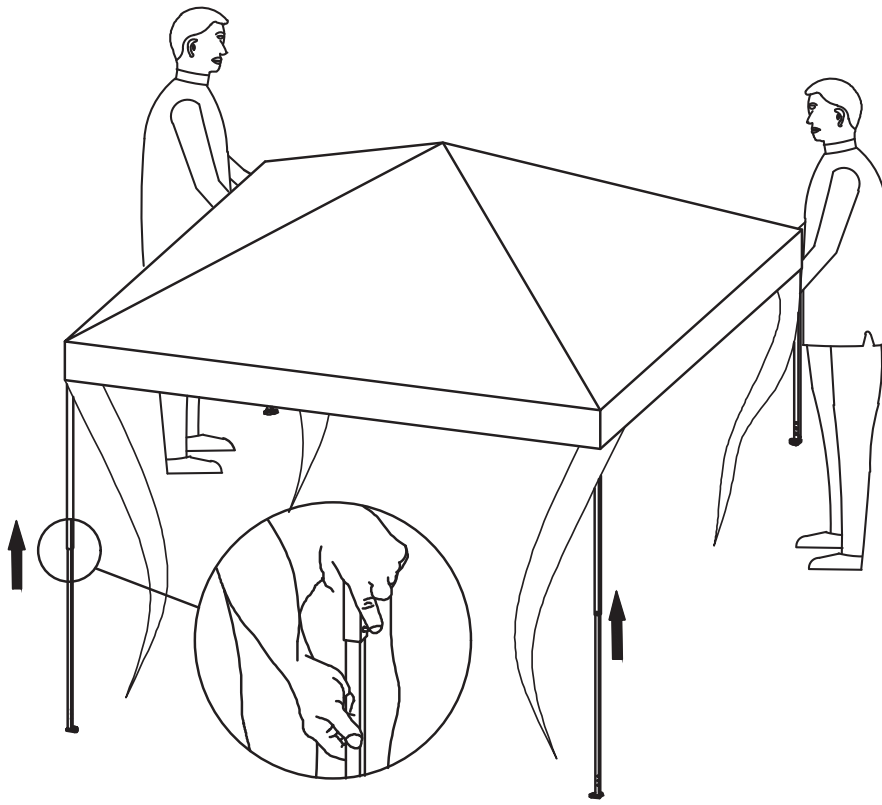

Step 8

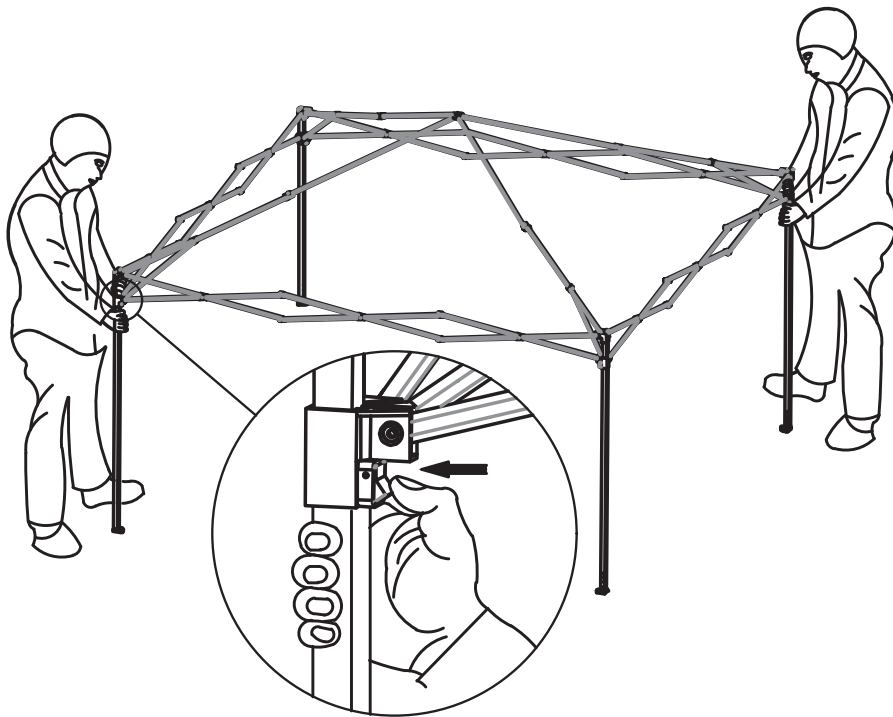

Step 9

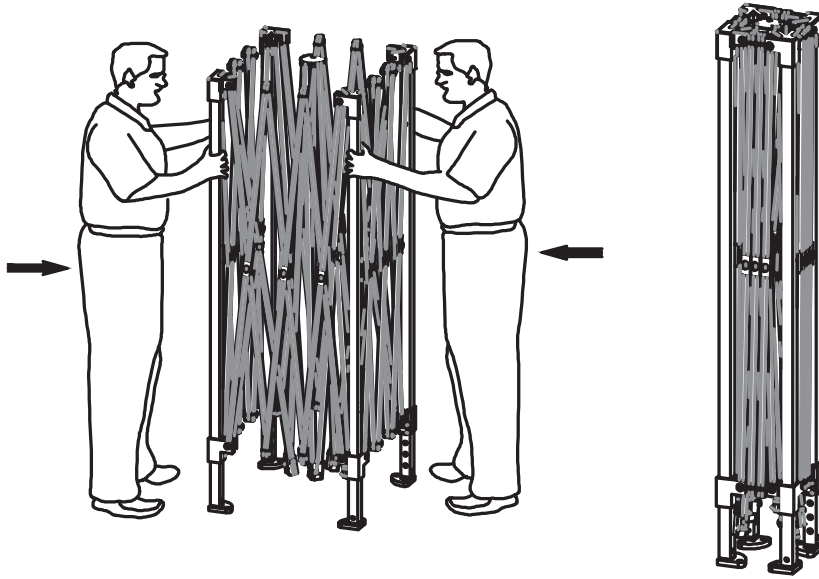

Step 10

