

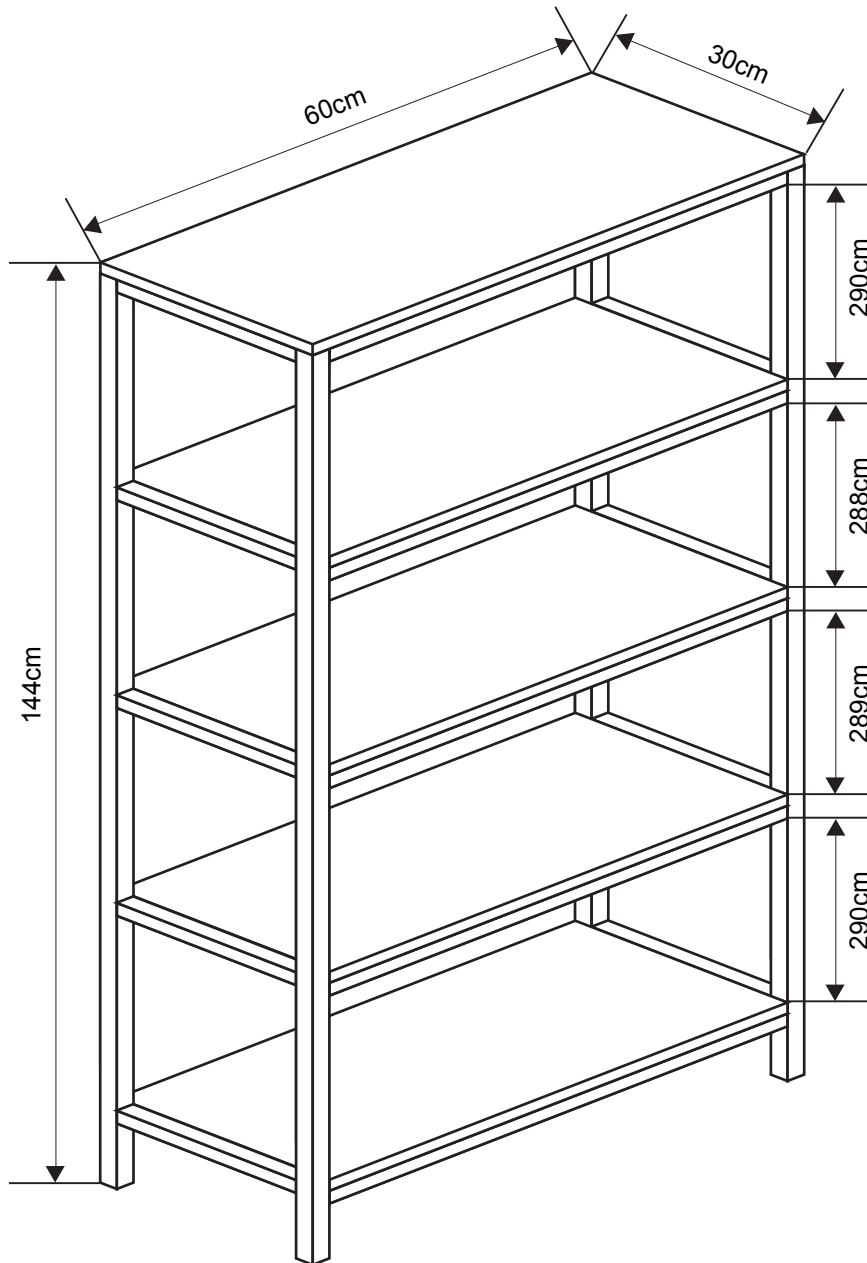

# GLOBAL PROCUREMENT AND MARKETING LIMITED

## 5 Tier Bookcase

Assembly Instructions - Please keep for future reference

BKSOAK5TR



| Dimensions                                  | No. people  | Assembly Time     | SKU #     |
|---|---|-------------------|-----------|
| Width: 60cm<br>Depth: 30cm<br>Height: 144cm |  | 30 mins (approx.) | BKSOAK5TR |

*thank you*

For purchasing this  
**GPM Limited**  
product

**Important** - Please read these instructions fully before starting assembly

If you need help or have damaged or missing parts, please email [aftersales@gpmfurniture.co.uk](mailto:aftersales@gpmfurniture.co.uk)



# Safety and Care Advice

**Important** - Please read these instructions fully before starting assembly

- Check you have all the components and tools listed on pages 4 and 5.
- Remove all fittings from the plastic bags and separate them into their groups.
- Keep children and animals away from the work area, small parts could choke if swallowed.
- Make sure you have enough space to lay out the parts before starting.
- Do not stand or put weight on the product, this could cause damage.
- Assemble the item as close to its final position (in the same room) as possible.
- Assemble on a soft, level surface to avoid damaging the unit or your floor.
- We do not recommend the use of power drill/drivers for inserting screws, as this could damage the unit. Only use hand screwdrivers.
- Dispose of all packaging carefully and responsibly.



We do not recommend the use of power drill/drivers for inserting screws, as this could damage the unit.

Only use hand screwdrivers.

- Dispose of all packaging carefully and responsibly.

## Care and Maintenance

- Only clean using a damp cloth and mild detergent, do not use bleach or abrasive cleaners.
- From time to time check that there are no loose screws on this unit.
- This product should not be discarded with household waste. Take to your local authority waste disposal centre.

**If you are unhappy with the product and wish to return it, please follow the retailer's returns procedure.**

# Exploded View

If you have damaged or missing components,  
email: [aftersales@gpmfurniture.co.uk](mailto:aftersales@gpmfurniture.co.uk)

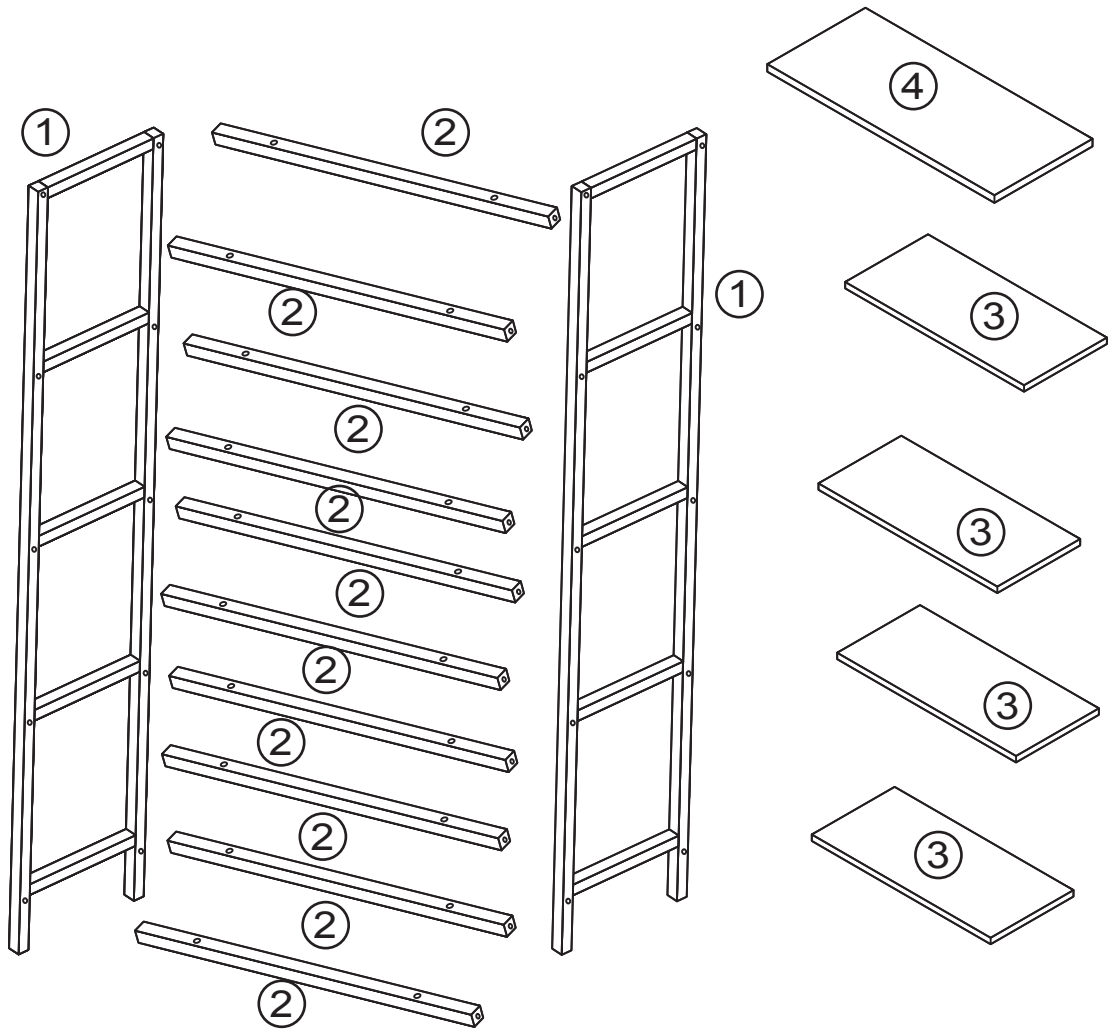







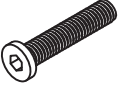

# Components - Fixings

If you have damaged or missing components,  
email: [aftersales@gpmfurniture.co.uk](mailto:aftersales@gpmfurniture.co.uk)

**Please check that you have all the components listed below before constructing your item.**

**Note:** The quantities below are the correct amount to complete the assembly. In some cases more fittings may be supplied than are required.

|     |   |     |   |     |  |     |  |
|-----|---|-----|---|-----|--|-----|--|
| (A) |  20pcs | (B) |  20pcs | (C) |  1pc | (D) |  1pc  |
| (E) |  1pc   | (F) |  1pc   | (G) |  1pc | (H) |  2pcs |
|     |   |     |   |     |  |     |  |
|     |   |     |   |     |  |     |  |
|     |   |     |   |     |  |     |  |
|     |   |     |   |     |  |     |  |

## Tools Required

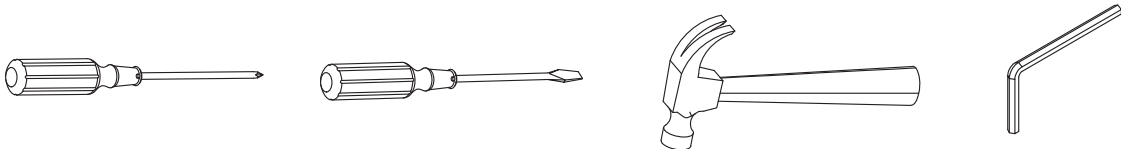

**Ruler - Use this to measure your screws (mm)**

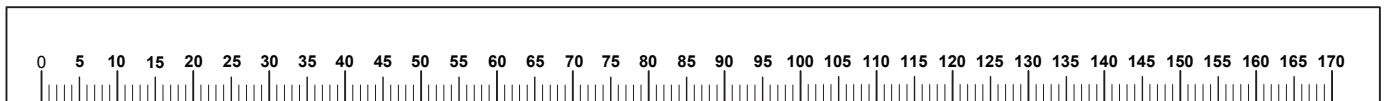

**Important - Please read these instructions fully before starting assembly**

If you need help or have damaged or missing parts, please email [aftersales@gpmfurniture.co.uk](mailto:aftersales@gpmfurniture.co.uk)

# Assembly Instructions

If you have damaged or missing components,  
email: [aftersales@gpmfurniture.co.uk](mailto:aftersales@gpmfurniture.co.uk)

## Step 1

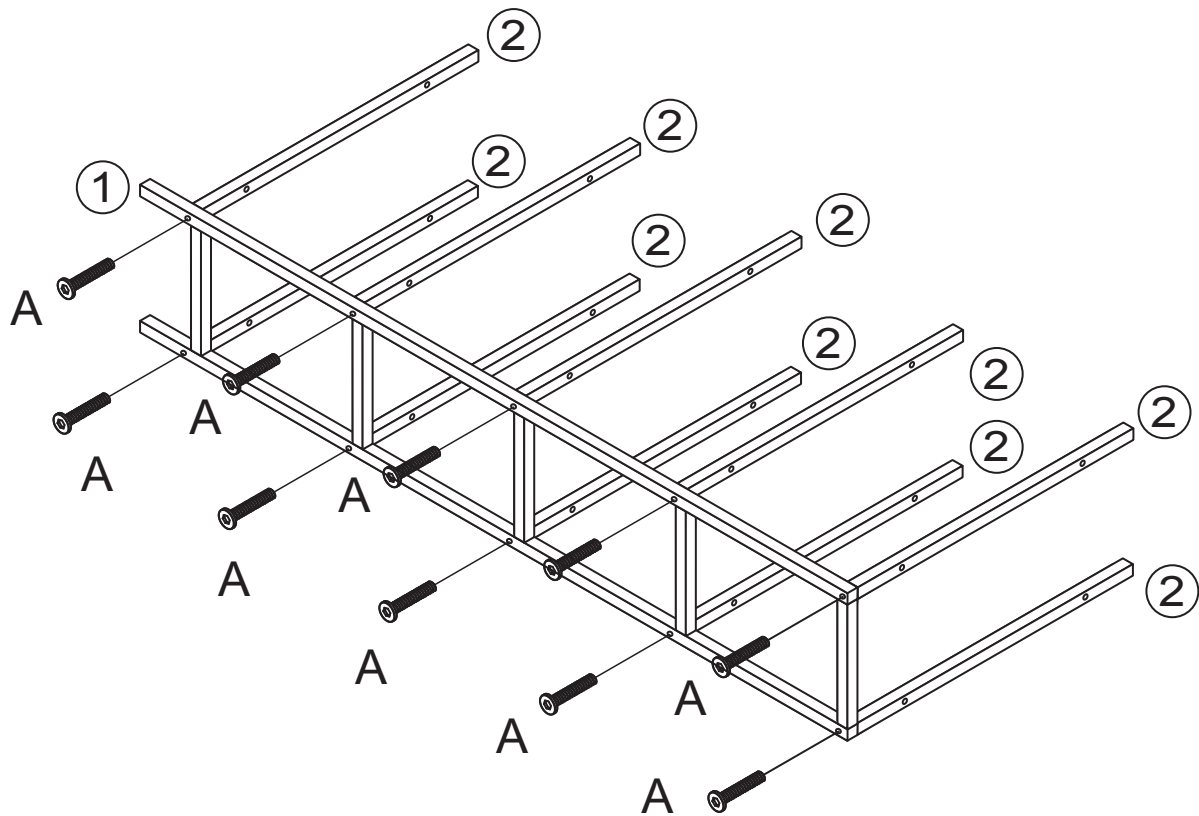

## Step 2

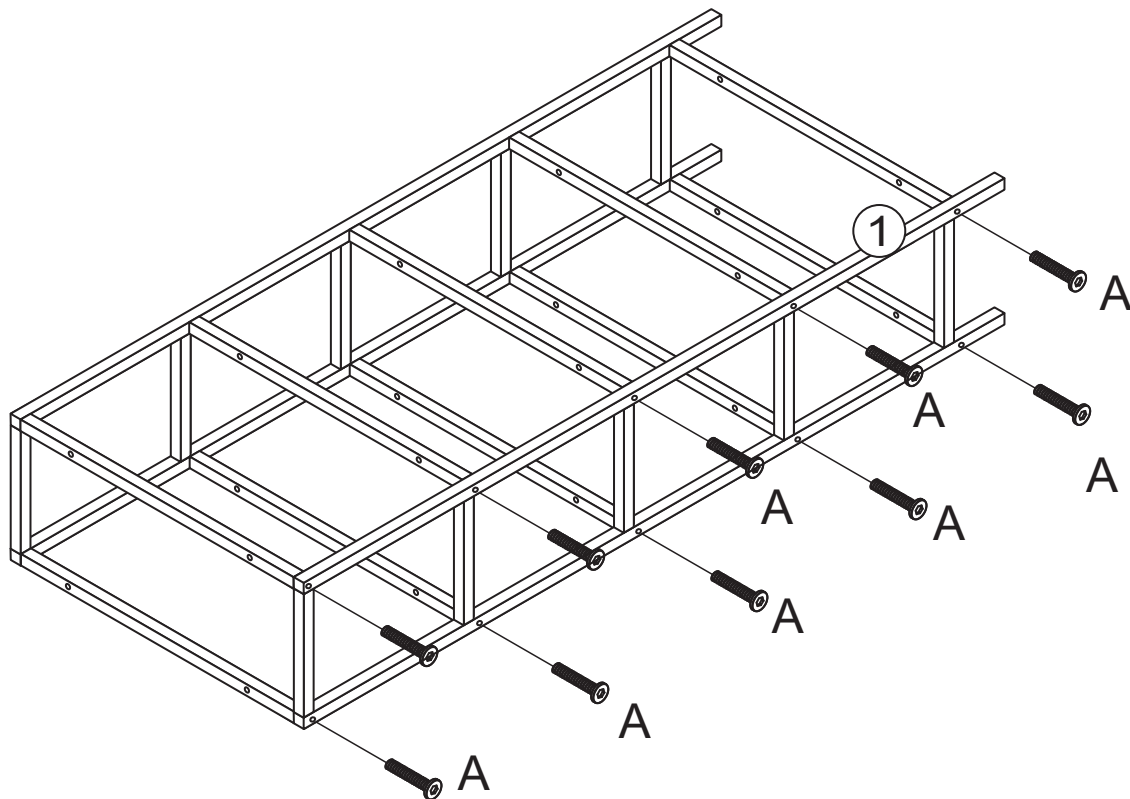

# Assembly Instructions

If you have damaged or missing components,  
email: [aftersales@gpmfurniture.co.uk](mailto:aftersales@gpmfurniture.co.uk)

## Step 3

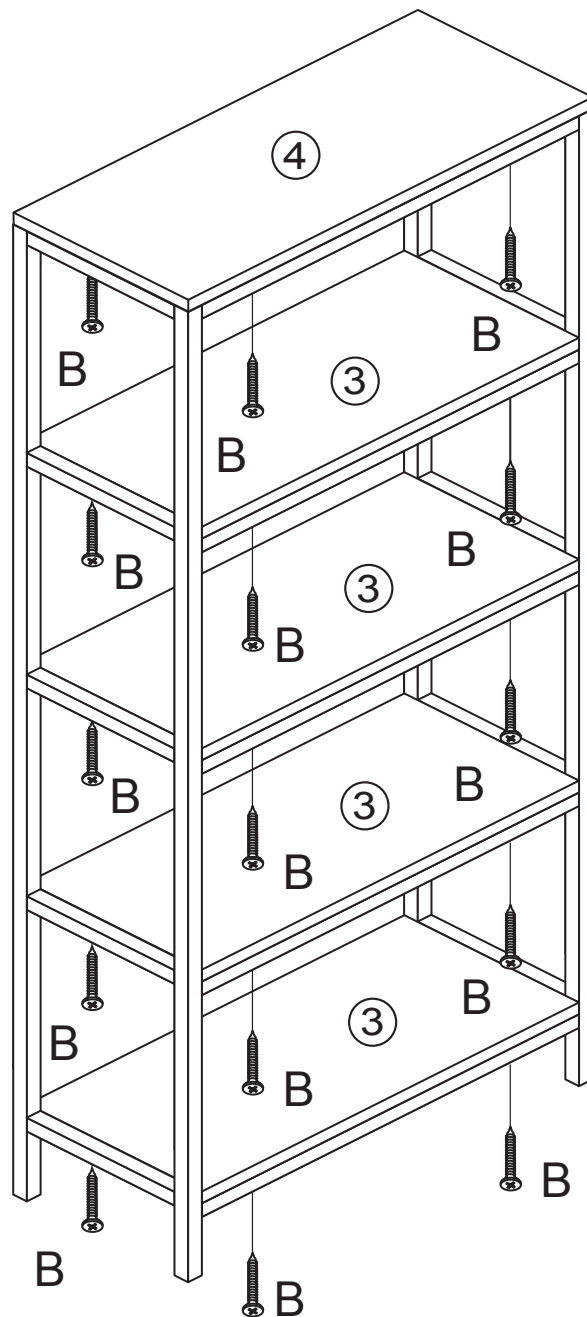

# Assembly Instructions

If you have damaged or missing components,  
email: [aftersales@gpmfurniture.co.uk](mailto:aftersales@gpmfurniture.co.uk)

## Step 4

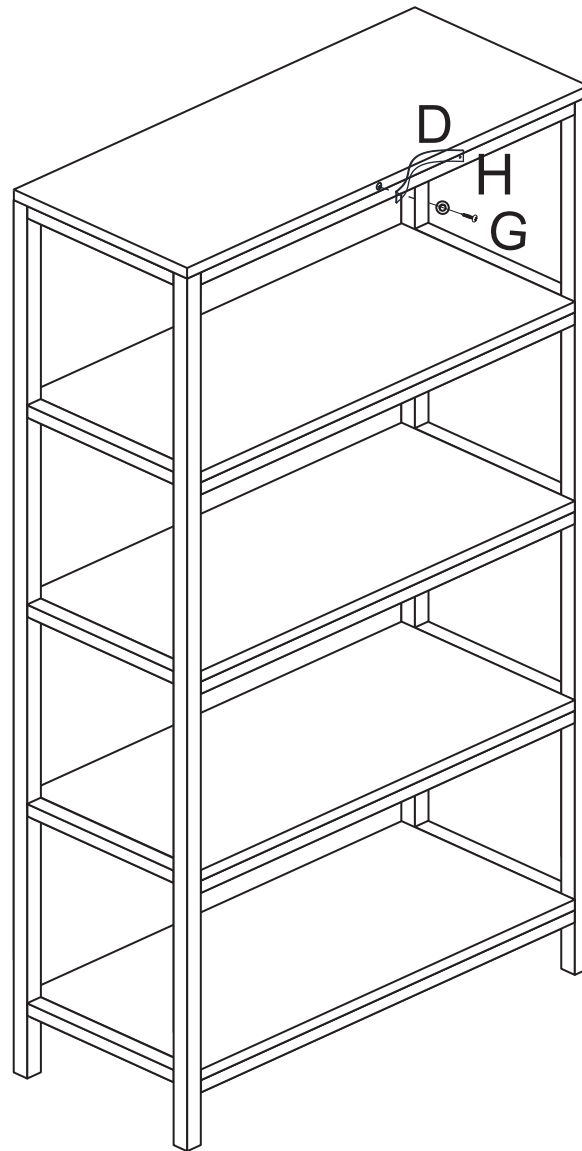

# Assembly Instructions

If you have damaged or missing components,  
email: [aftersales@gpmfurniture.co.uk](mailto:aftersales@gpmfurniture.co.uk)

## Step 5

