

GLOBAL PROCUREMENT AND MARKETING LIMITED

2 Drawers Chest

Assembly Instructions – Please keep for future reference

BSDCAM2GY

BSDCAM2WT

BSDCAM2GR

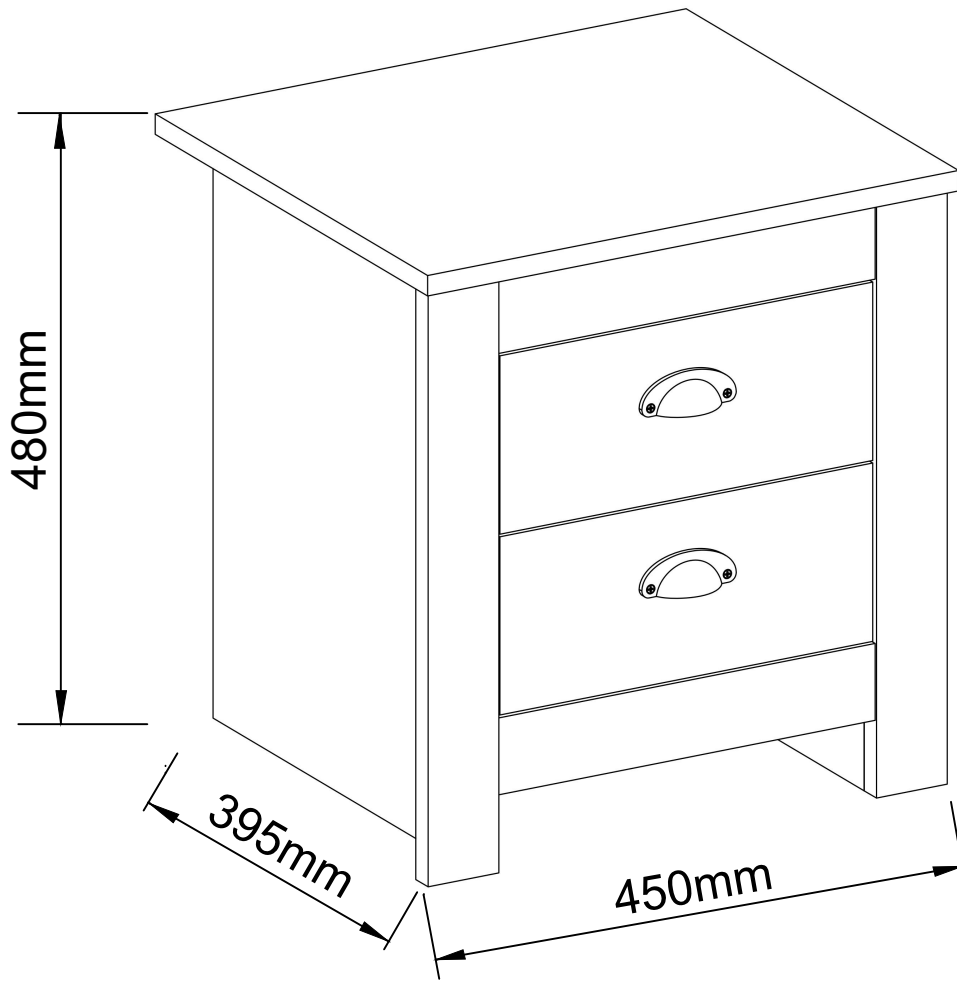

Dimensions	No. people	Assembly Time	SKU #
Width: 45 cm Depth: 39.5 cm Height: 48 cm		40 mins (approx.)	BSDCAM2GY BSDCAM2WT BSDCAM2GR

thank you

For purchasing this
GPM Limited
product

Important

- PLEASE READ THESE INSTRUCTIONS FULLY BEFORE STARTING ASSEMBLY
- PLEASE DO NOT THROW THE PACKAGING AWAY UNTIL YOU ARE SATISFIED WITH PURCHASE, GOODS NEED TO BE RETURNED IN ORIGINAL PACKAGING.

If you need help or have damaged or missing parts, please email aftersales@gpmfurniture.co.uk

⚠ Safety and Care Advice

Important – Please read these instructions fully before starting assembly

- Check you have all the components and tools listed on pages 4 and 5.
- Remove all fittings from the plastic bags and separate them into their groups.
- Keep children and animals away from the work area, small parts could choke if swallowed.
- Make sure you have enough space to lay out the parts before starting.
- Do not stand or put weight on the product, this could cause damage.
- Assemble the item as close to its final position (in the same room) as possible.
- Assemble on a soft, level surface to avoid damaging the unit or your floor.
- We do not recommend the use of power drill/drivers for inserting screws, as this could damage the unit. Only use hand screwdrivers.
- Dispose of all packaging carefully and responsibly.



use of power drill/drivers for inserting screws, as this could damage the unit.

Only use hand screwdrivers.

- Dispose of all packaging carefully and responsibly.

Care and Maintenance

- Only clean using a damp cloth and mild detergent, do not use bleach or abrasive cleaners.
- From time to time check that there are no loose screws on this unit.
- This product should not be discarded with household waste. Take to your local authority waste disposal centre.

SPECIAL TIPS FOR FITTING CAM-LOCKS AND QUICKFIT

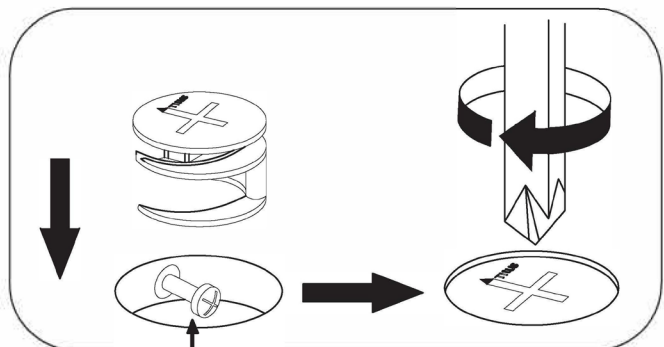
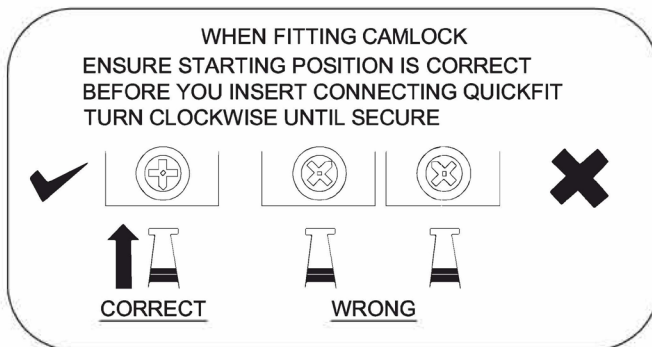

Quickfit head needs to be in centre

QUICKFIT

Tighten until shoulder is flush with panel. Do not overtighten or undertighten (see example below)

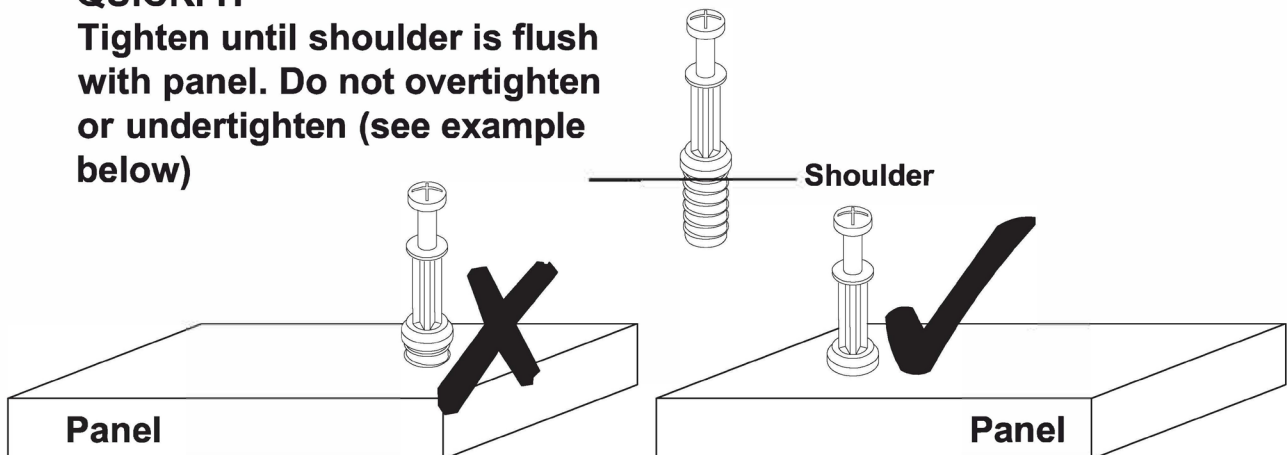

If you are unhappy with the product and wish to return it, please follow the retailer's returns procedure.

Exploded View

If you have damaged or missing components,
email: aftersales@gpmfurniture.co.uk

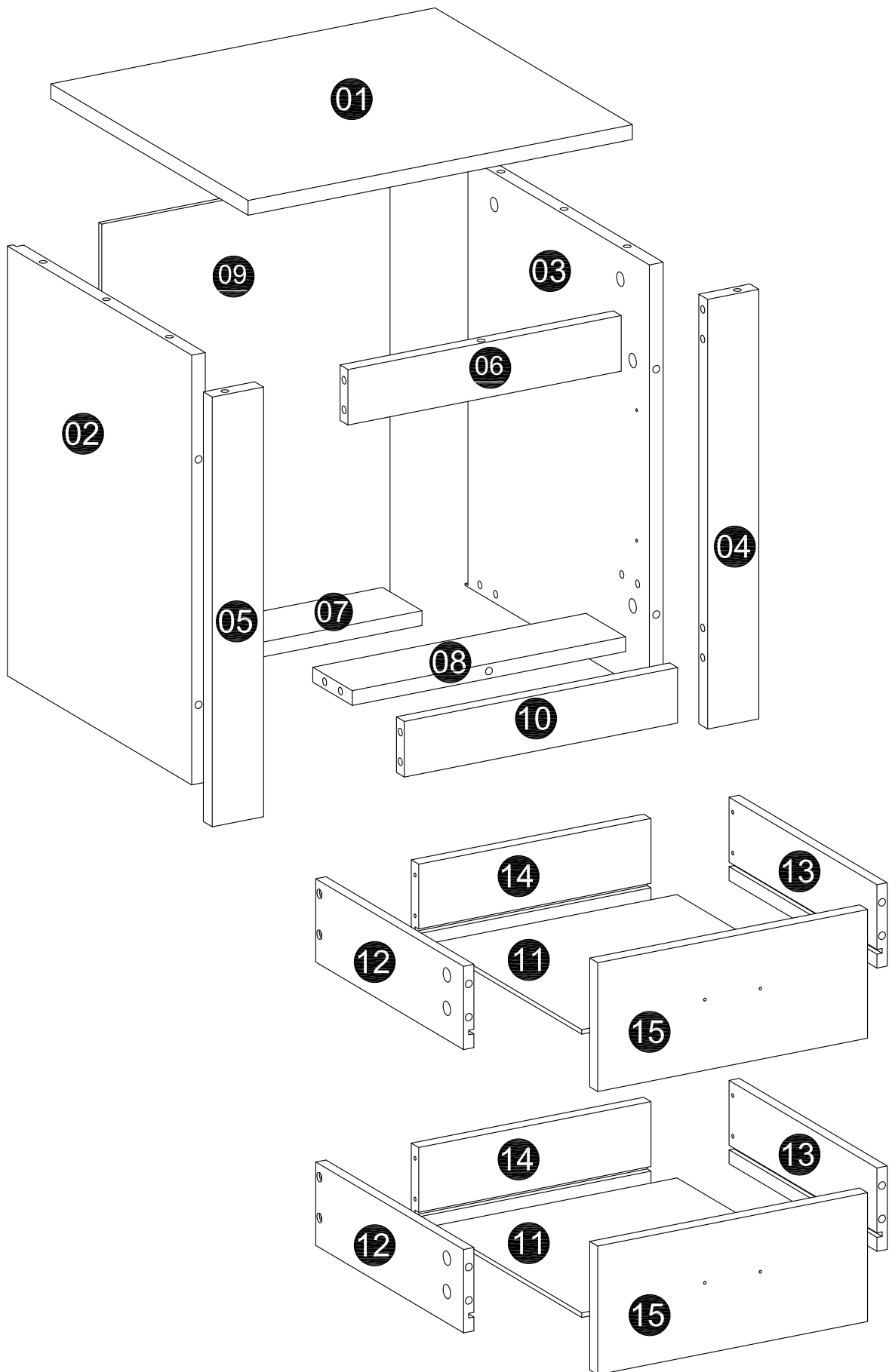









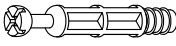
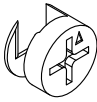

Components - Fixings

If you have damaged or missing components,
email: aftersales@gpmfurniture.co.uk

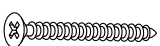
Please check that you have all the components listed below before constructing your item.

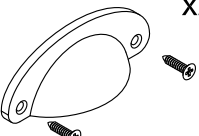
Note: The quantities below are the correct amount to complete the assembly. In some cases more fittings may be supplied than are required.

<p>A Cam dowel x32</p> 	<p>B Lock x32</p> 	<p>C Wood dowel x6</p> 	<p>D Drawer rail x2</p> <p>CR </p> <p>CL </p> <p>DR </p> <p>DL </p>	<p>E Screw x8</p>  <p>Ø3.5*35mm</p>
<p>F Screw x16</p>  <p>Ø3.5*14mm</p>	<p>G Nail x20</p> 	<p>H Handle&screw x2</p> 	<p>I Nail leg x4</p> 	

Tools Required

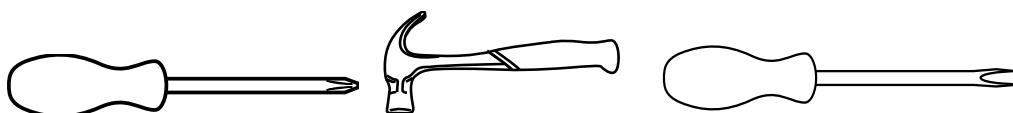

Ruler – Use this to measure your screws (mm)

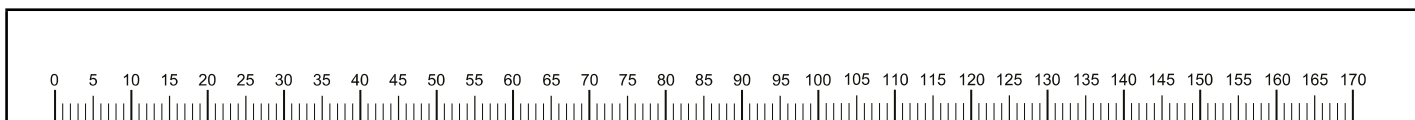

Important – Please read these instructions fully before starting assembly

If you need help or have damaged or missing parts, please email aftersales@gpmfurniture.co.uk

Assembly Instructions

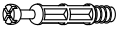

If you have damaged or missing components,
email: aftersales@gpmfurniture.co.uk

01

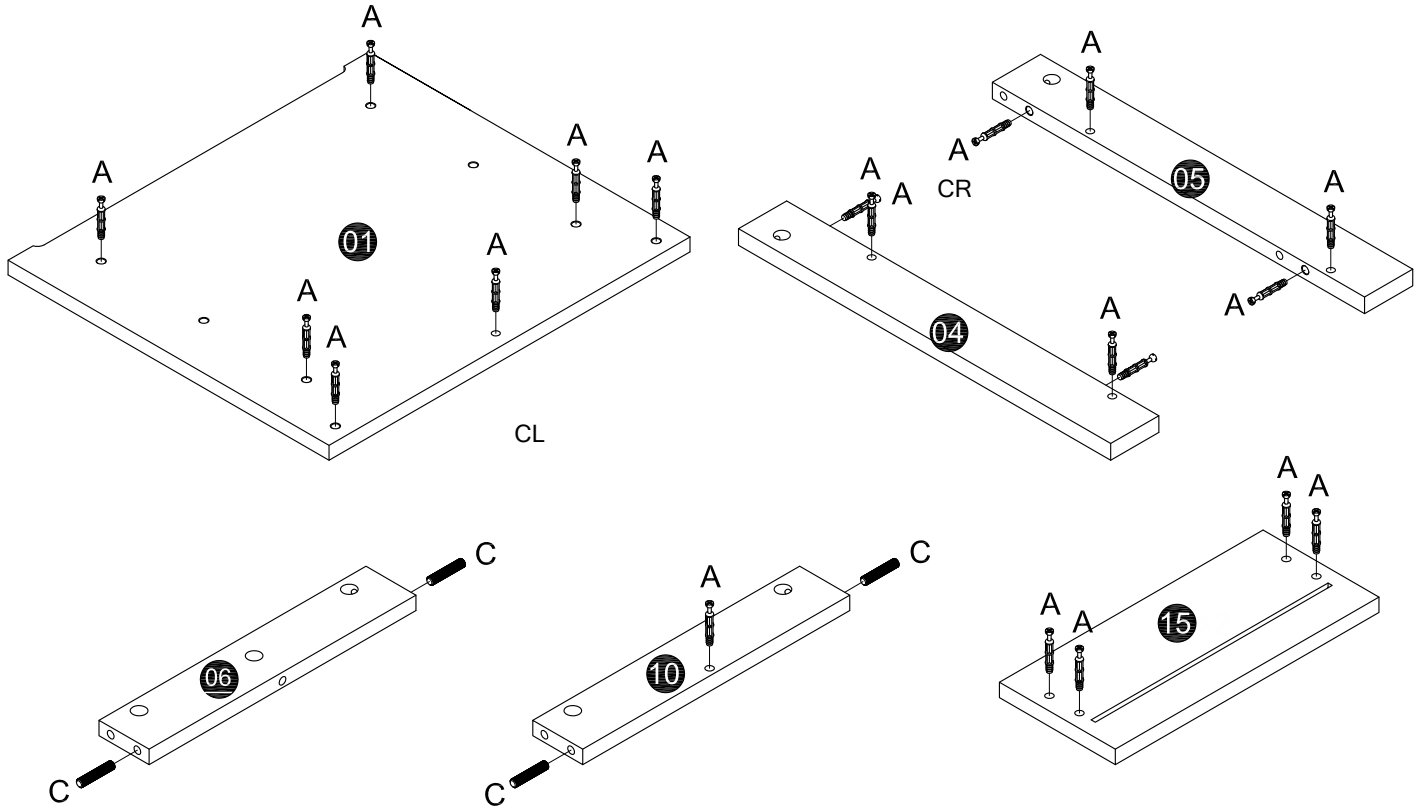
C wood dowel x4	A CAM dowel x24
	

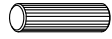
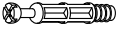

02

F Screw x8  Ø3.5*14mm	D Drawer rail x2 CR  CL 	C Wood dowel x2 	A Cam dowel x8 
--	--	--	---

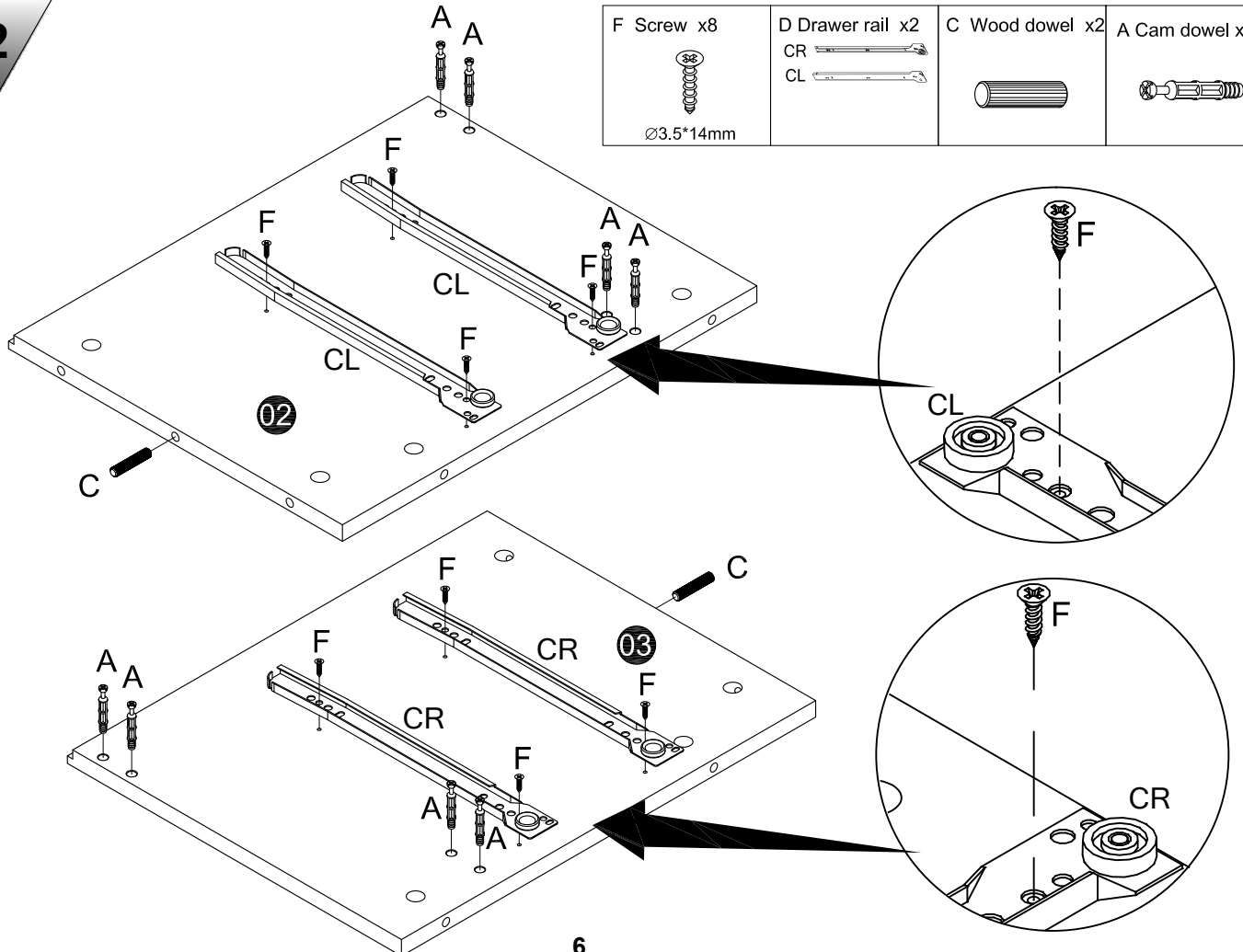

03

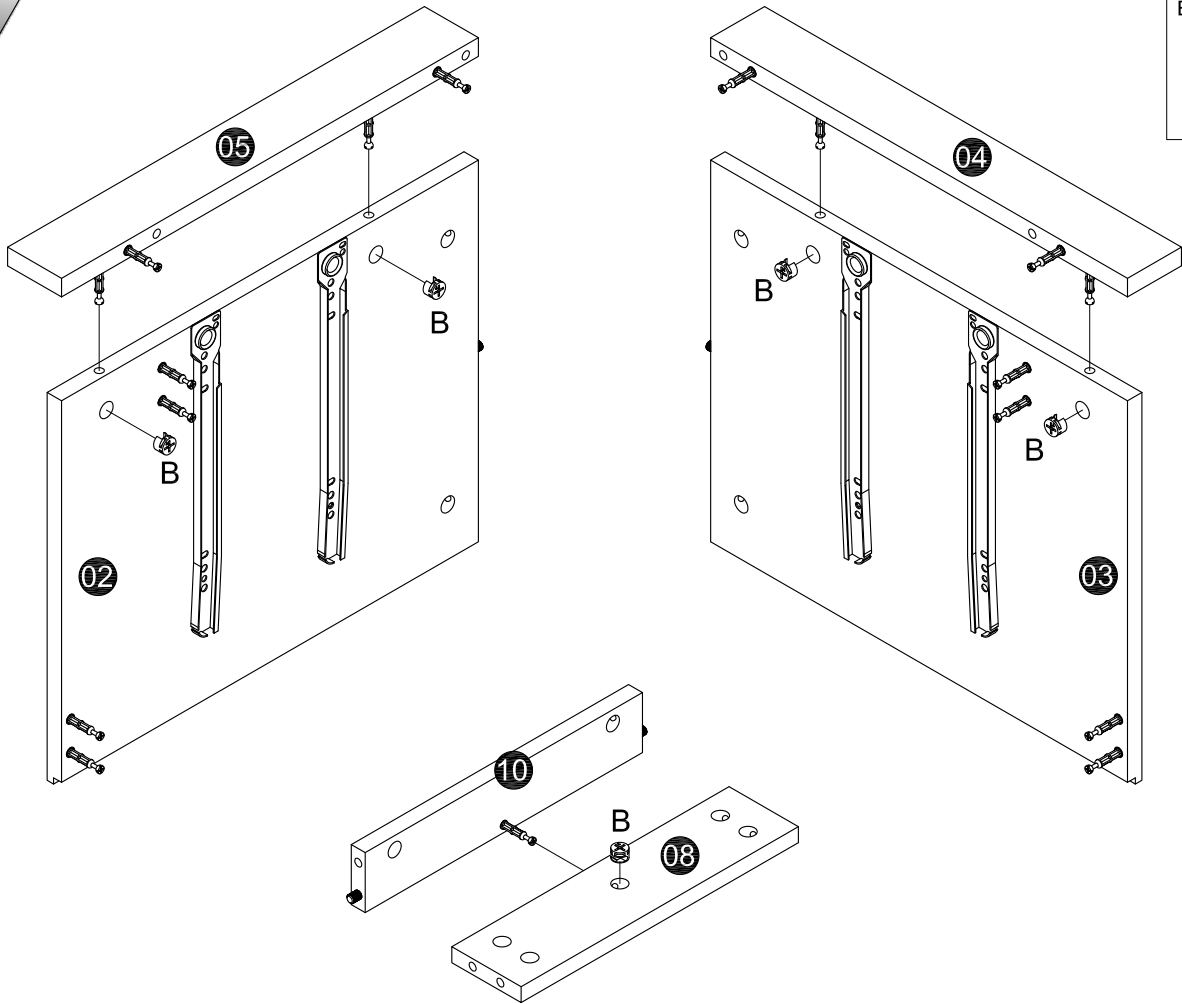

B Lock x5



04

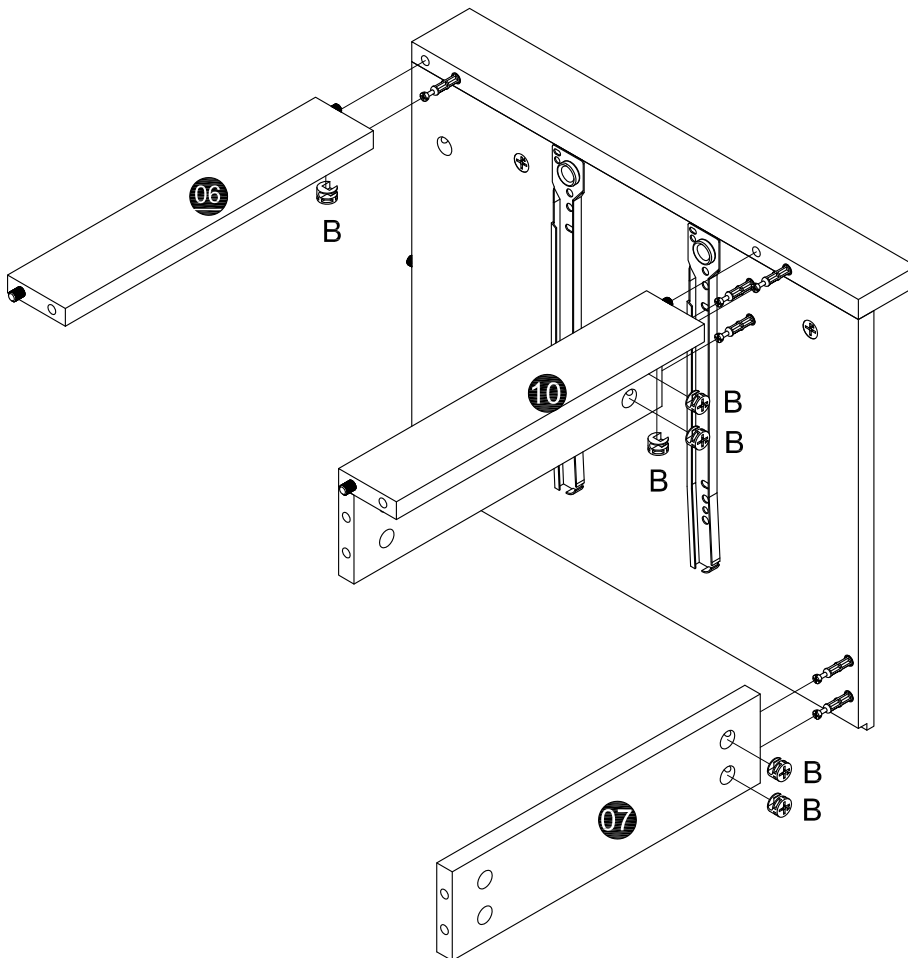

B Lock x6



05

B Lock x6

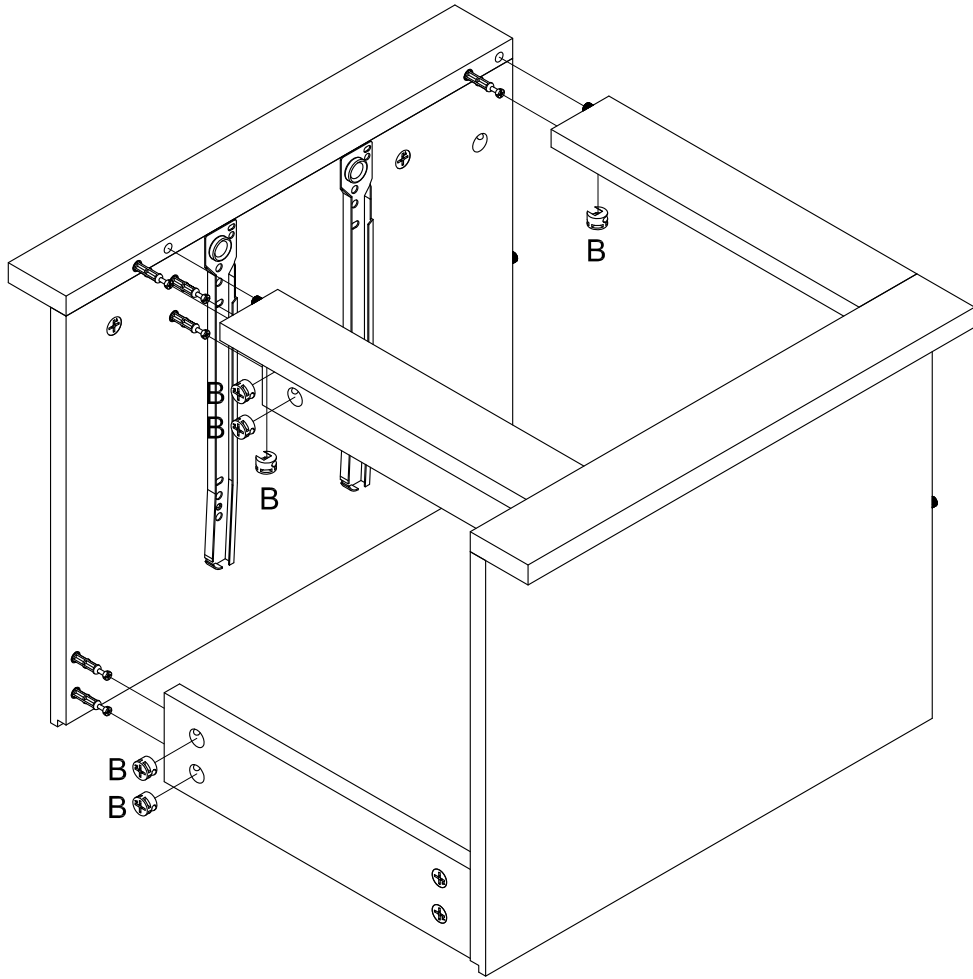

06

B Lock x7

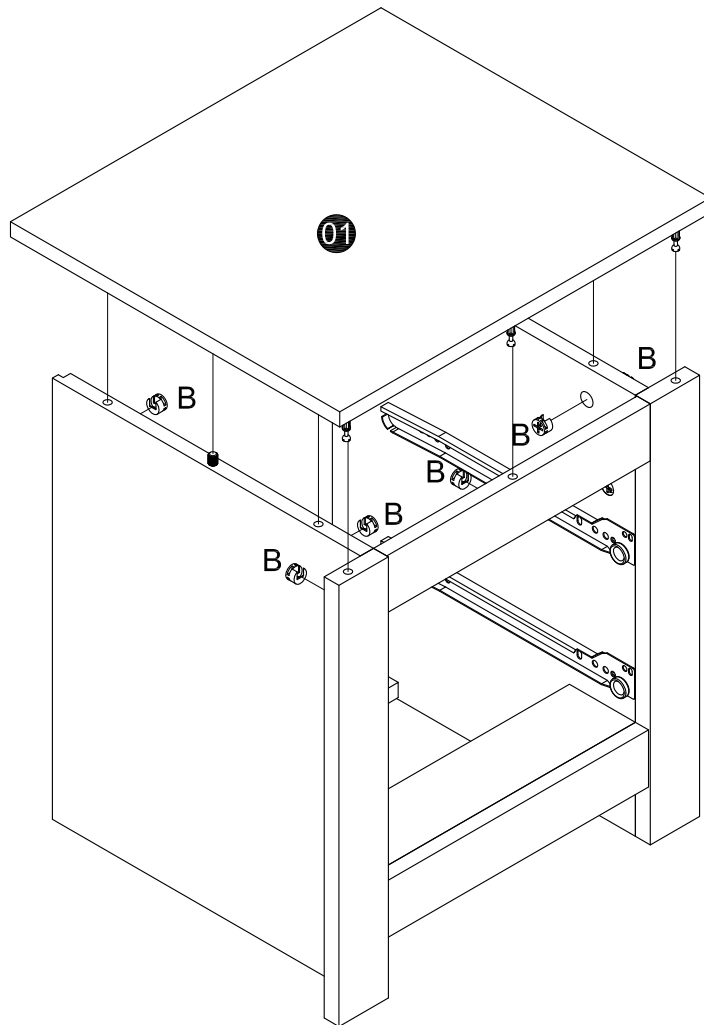

07

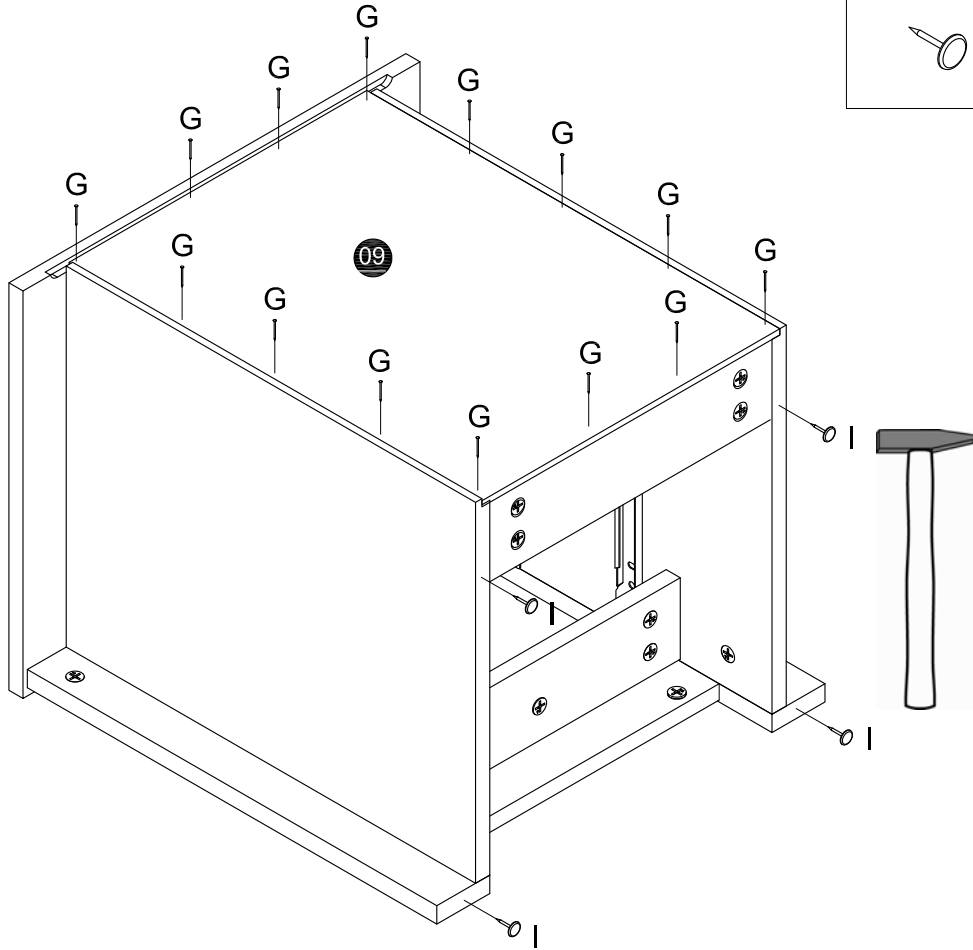

I Nail leg x4



G Nail



08

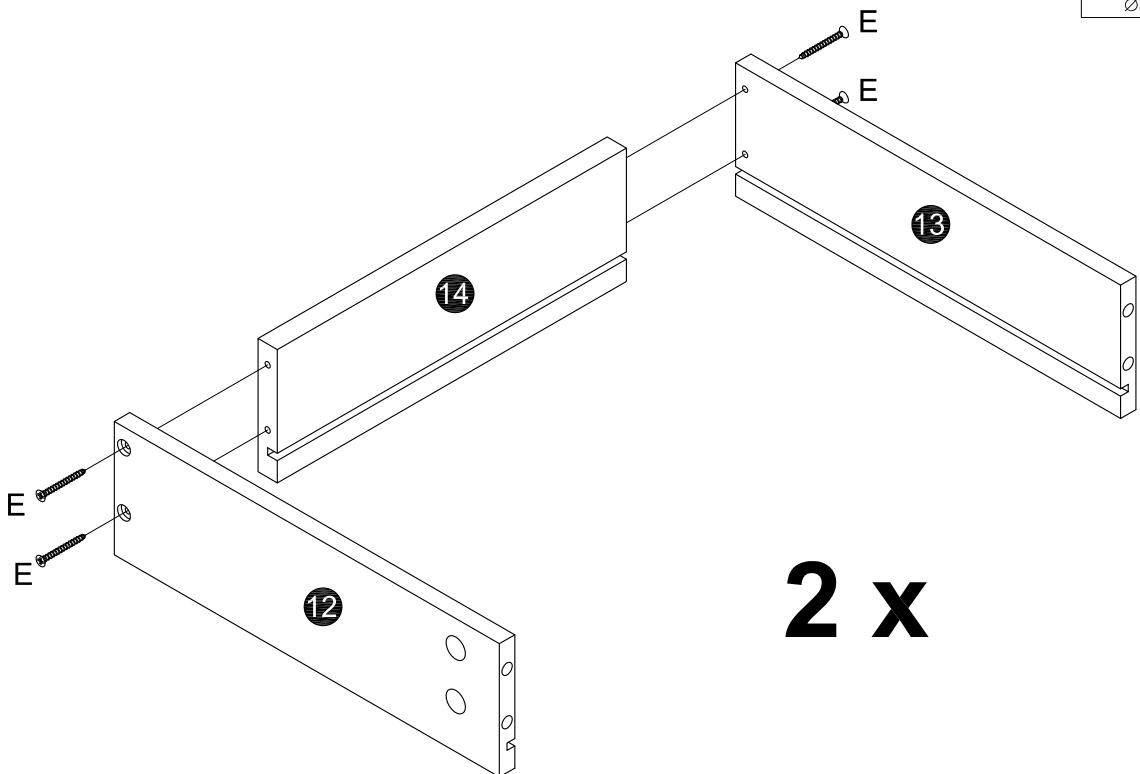

E Screw x8

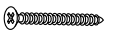

Ø3.5*35mm

2 x

09

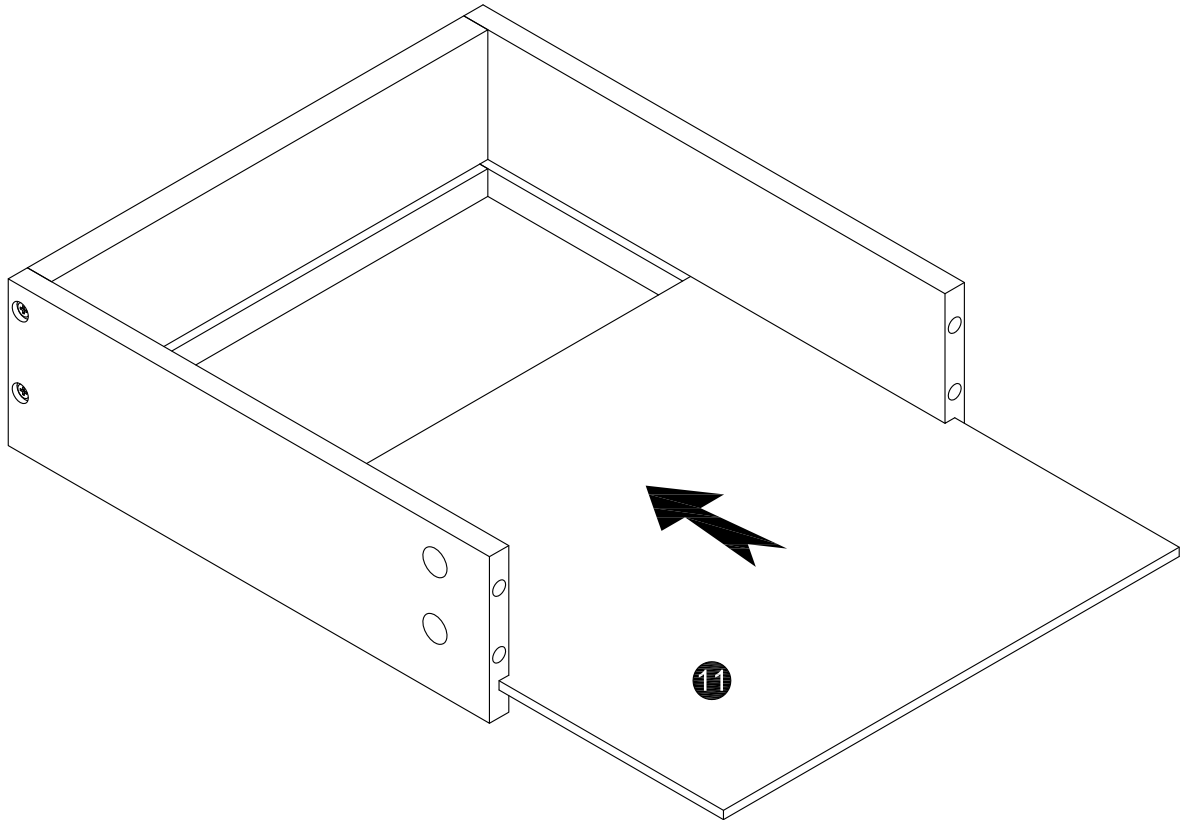

2 x

10

B Lock x8

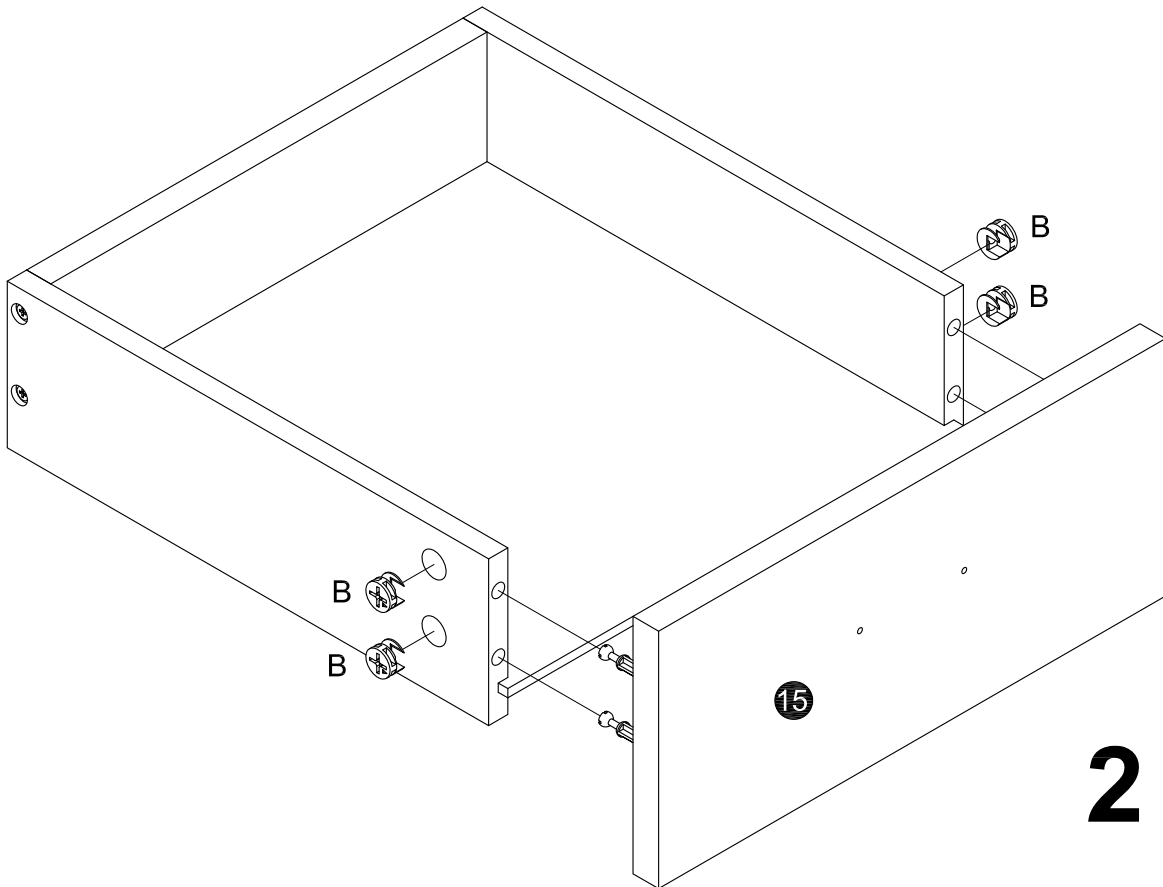

2 x

11

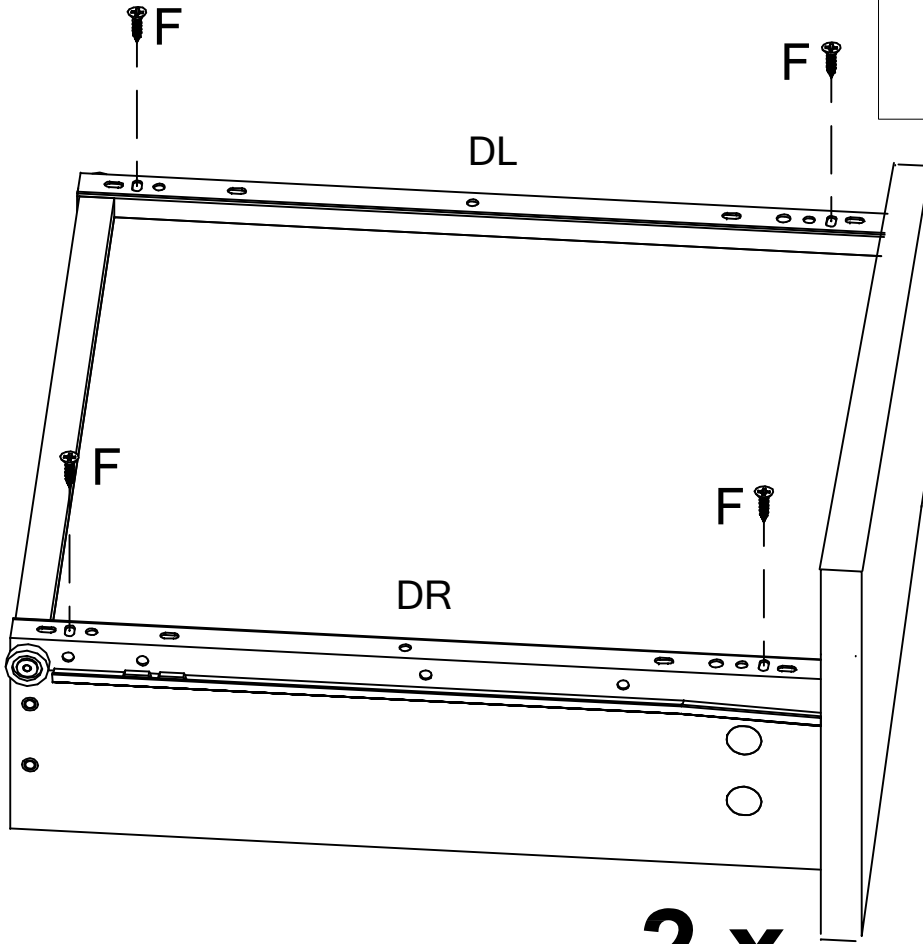

2 x

12

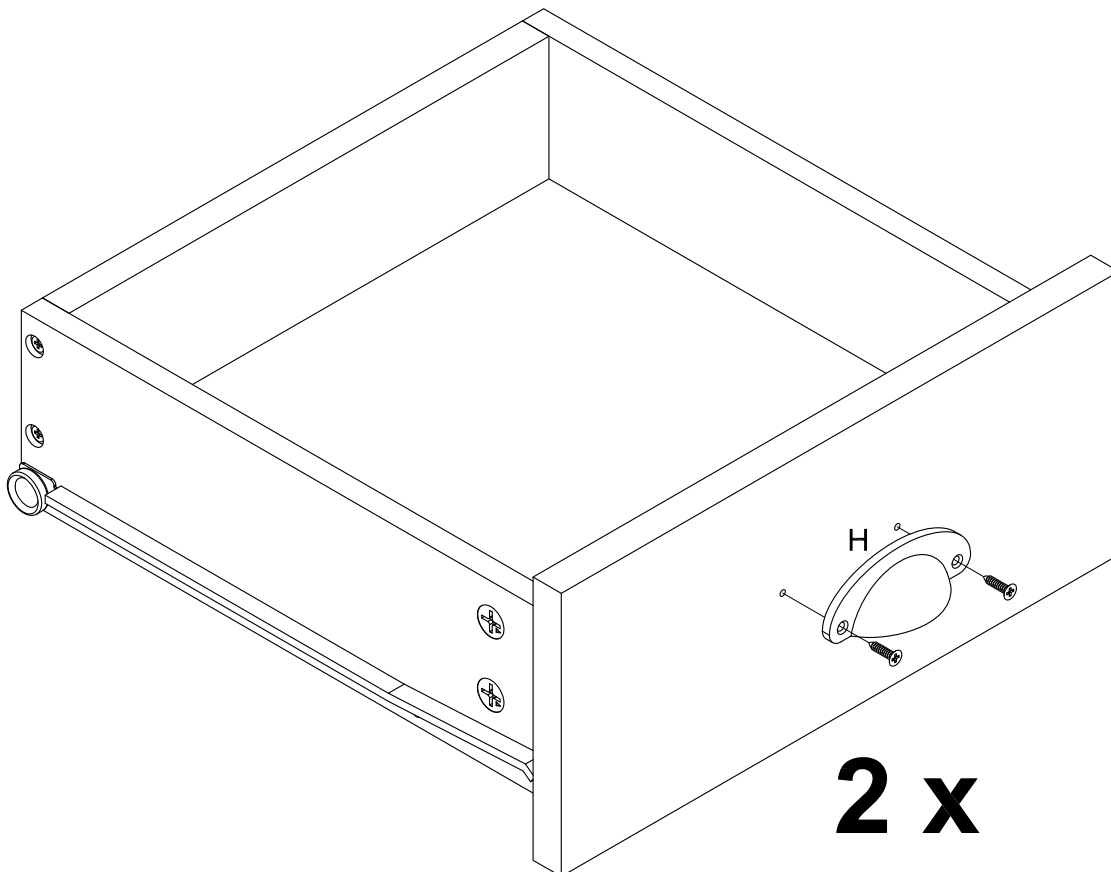

2 x

