

# GLOBAL PROCUREMENT AND MARKETING LIMITED

## KIDS DRESSING TABLE

Assembly Instructions – Please keep for future reference

CODE 3

DRSBEL

CODE 4

CODE 2

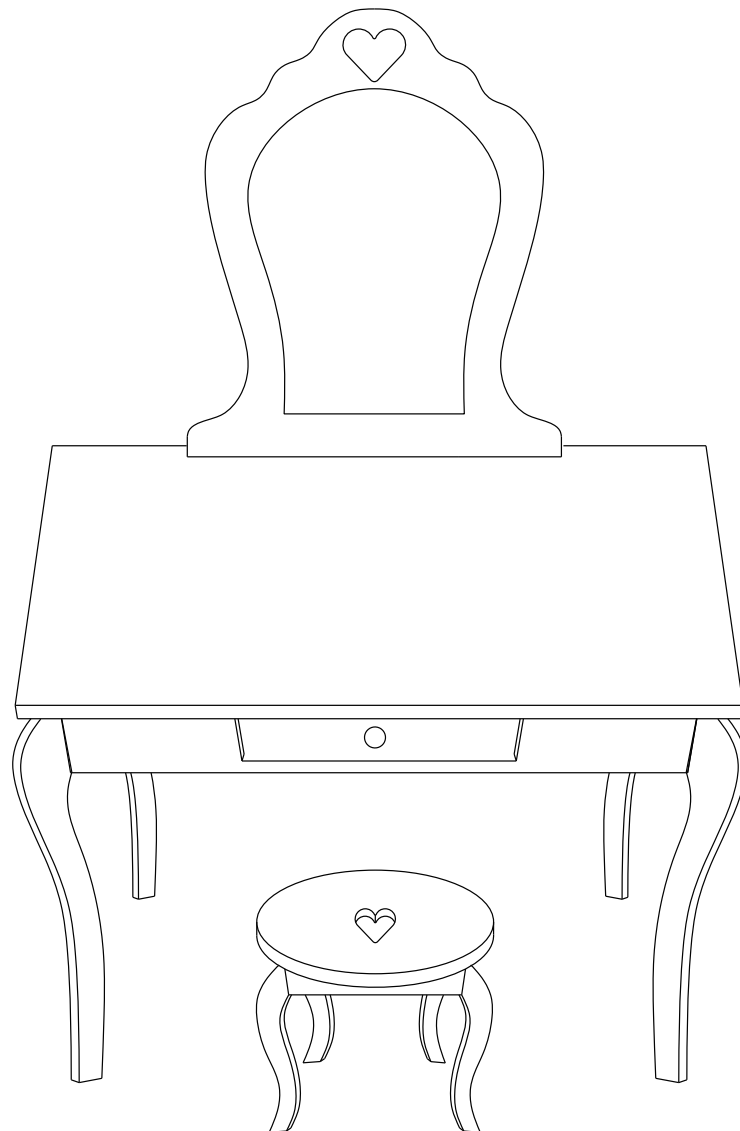

Dimensions		No. people	Assembly Time	OW #
table: Width: 65cm Depth: 40cm Height: 110cm	stool: Width: 30cm Depth: 30cm Height: 35.5cm		20 mins (approx.)	GP0775

*thank you*

For purchasing this  
**GPM Limited**  
product

**Important – Please read these instructions fully before starting assembly**

If you need help or have damaged or missing parts, please email [aftersales@gpmfurniture.co.uk](mailto:aftersales@gpmfurniture.co.uk)

## Safety and Care Advice

Important – Please read these instructions fully before starting assembly

- Check you have all the components and tools listed on pages 4 and 5.
- Remove all fittings from the plastic bags and separate them into their groups.
- Keep children and animals away from the work area, small parts could choke if swallowed.
- Make sure you have enough space to lay out the parts before starting.
- Do not stand or put weight on the product, this could cause damage.
- Assemble the item as close to its final position (in the same room) as possible.
- Assemble on a soft, level surface to avoid damaging the unit or your floor.
- We do not recommend the use of power drill/drivers for inserting screws, as this could damage the unit.



- Only use hand screwdrivers.
- Dispose of all packaging carefully and responsibly.

### Glass Warnings

1. Do not place very hot or very cold items against or in close proximity to glass surfaces unless an adequately thick insulating material is used to prevent such items from coming into contact with the glass.
2. Do not strike the glass with hard or pointed items.
3. When cleaning glass panels or mirrors use a damp cloth or leather with washing up liquid or soft soap if necessary: do not use washing powders or any other substance containing abrasives since these substances can scratch glass.
4. It is essential that this unit is fixed to a wall with the fixings provided (if applicable).
5. This product complies with BS7449: 1991  
Imported by Global Procurement and Marketing Ltd  
Model no. **FH-KF200011** Batch no. **GP0775**  
Dimensions: **table: 65\*40\*110cm stool: 30\*30\*35.5cm**.
6. If a glass component is chipped or broken, replace with glass of the type described above. Consult the manufacturer, retailer or agent with regard to obtaining a manufacturing specification and shape for replacement glass quoting the model number and batch number or date of manufacture.

### Care and Maintenance

- Only clean using a damp cloth and mild detergent, do not use bleach or abrasive cleaners.
- From time to time check that there are no loose screws on this unit.
- This product should not be discarded with household waste. Take to your local authority waste disposal centre.

If you are unhappy with the product and wish to return it, please follow the retailer's returns procedure.





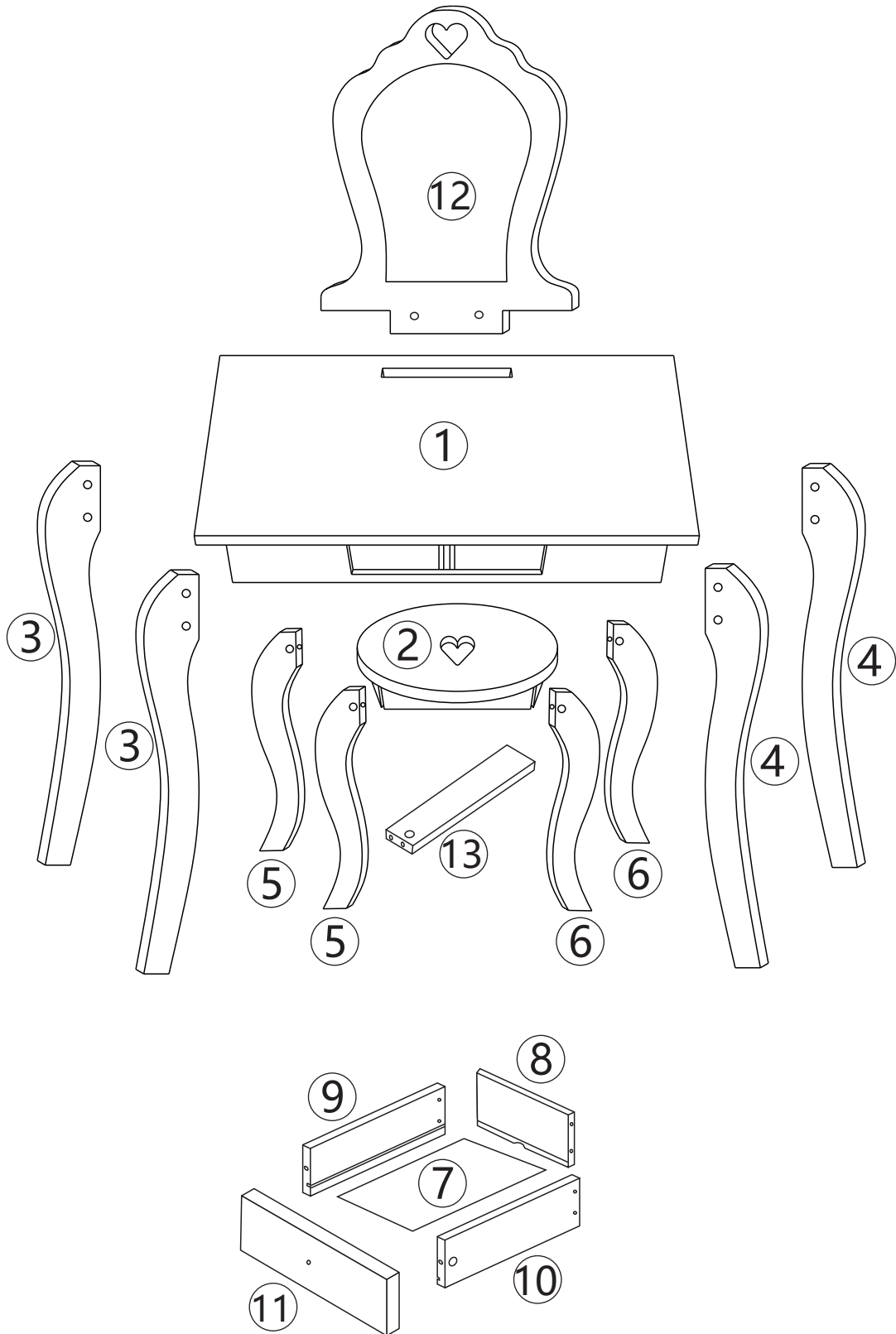

# Exploded View

If you have damaged or missing components,  
email: [aftersales@gpmfurniture.co.uk](mailto:aftersales@gpmfurniture.co.uk)

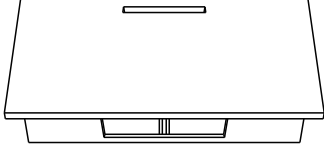
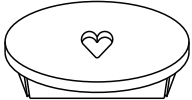

# Components - Panels

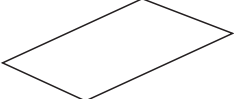
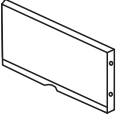
If you have damaged or missing components,  
email: [aftersales@gpmfurniture.co.uk](mailto:aftersales@gpmfurniture.co.uk)

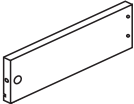
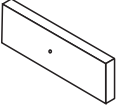
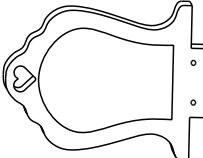
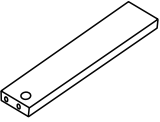









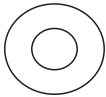
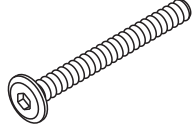

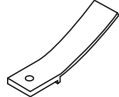

Part No	Description	Qty	Size (mm)	Thickness (mm)
1		1PC	650X400	15
2		1PC	300X300	15
3		2PCS	582X82.5	18
4		2PCS	582X82.5	18
5		2PCS	340X72	18
6		2PCS	340X72	18
7		1PC	297X209	3
8		1PC	200X51	12
9		1PC	300X54	12
10		1PC	300X54	12
11		1PC	264X69	12
12		1PC	540X380	12
13		1PC	300X60	15

# Components - Fixings

If you have damaged or missing components,  
email: [aftersales@gpmfurniture.co.uk](mailto:aftersales@gpmfurniture.co.uk)

**Please check that you have all the components listed below before constructing your item.**

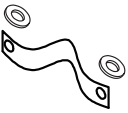
**Note:** The quantities below are the correct amount to complete the assembly. In some cases more fittings may be supplied than are required.

(A) X12		(B) X12	 6X55mm	(C) X1		(D) X6	 4x30mm	(E) X1	
(F) X3		(G) X1	 3X12mm	(H) X3		(I) X1		(J) X1	 4x25mm
(K) X12		(L) X2	 4x20mm	(M) X1		(N) X1	 4x12mm	(O) X1	
(P) X1		(Q) X14							

## Tools Required



**Ruler** – Use this to measure your screws (mm)

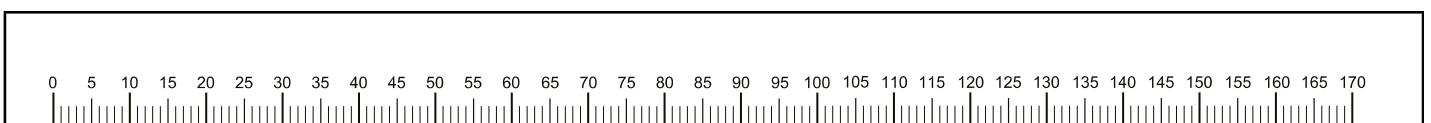

**Important** – Please read these instructions fully before starting assembly

If you need help or have damaged or missing parts, please email [aftersales@gpmfurniture.co.uk](mailto:aftersales@gpmfurniture.co.uk)

# Assembly Instructions

If you have damaged or missing components,  
email: [aftersales@gpmfurniture.co.uk](mailto:aftersales@gpmfurniture.co.uk)

1

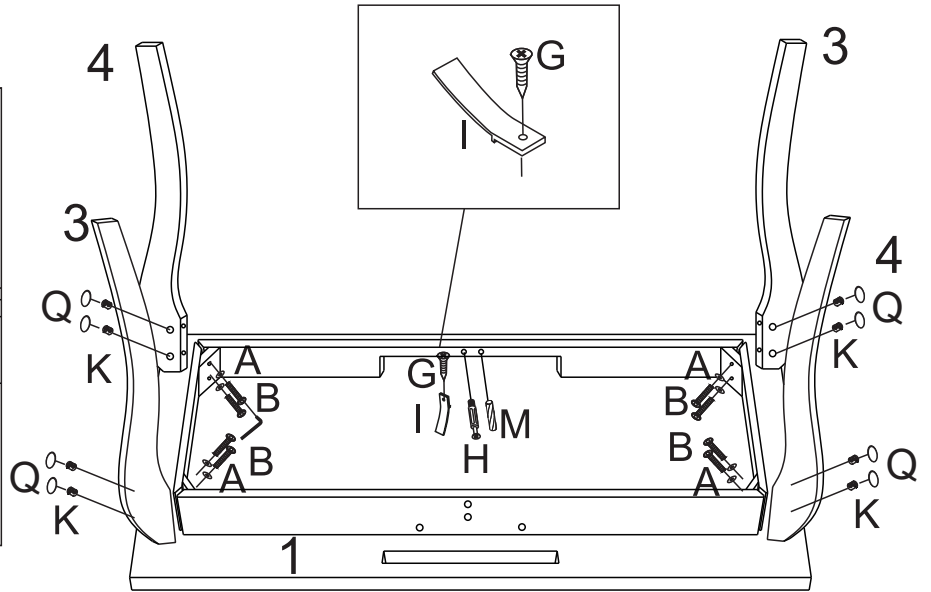
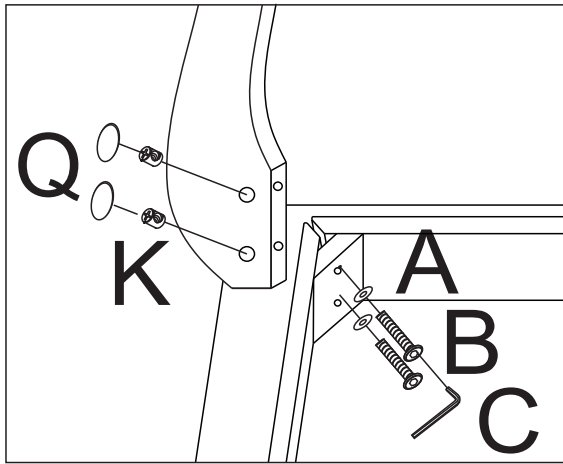

2

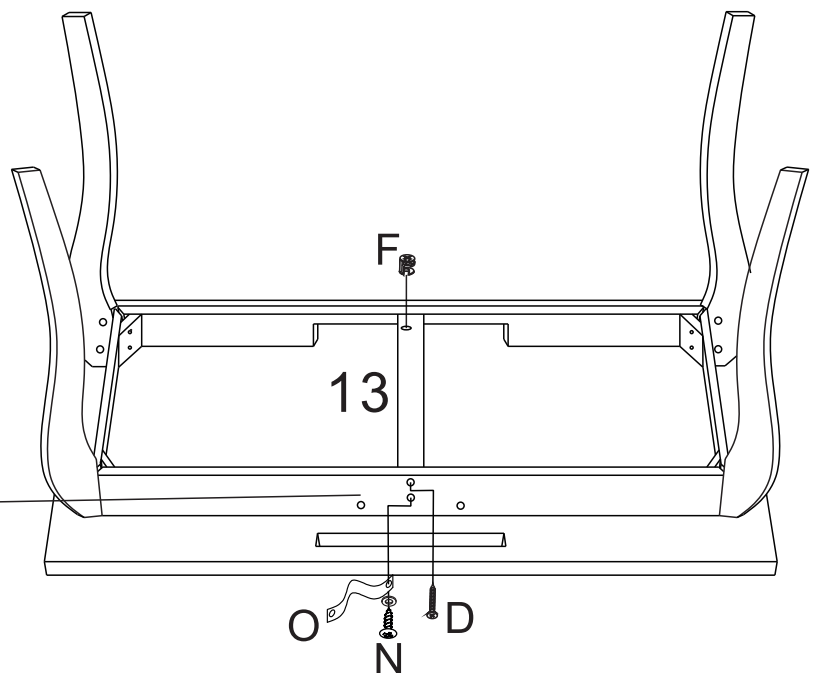
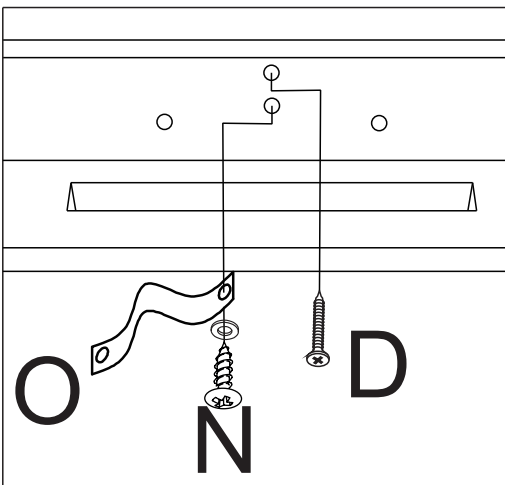

3

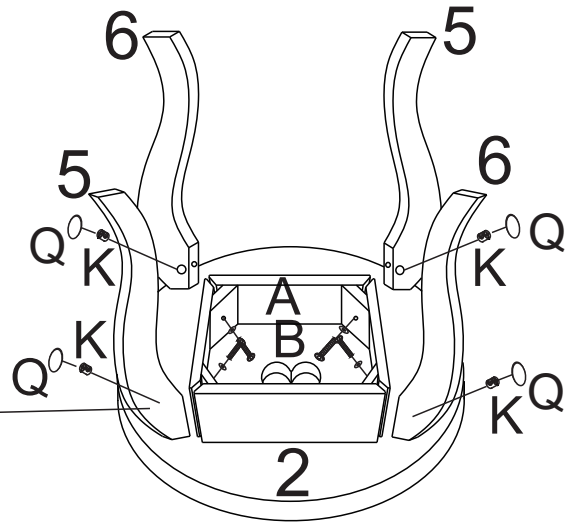
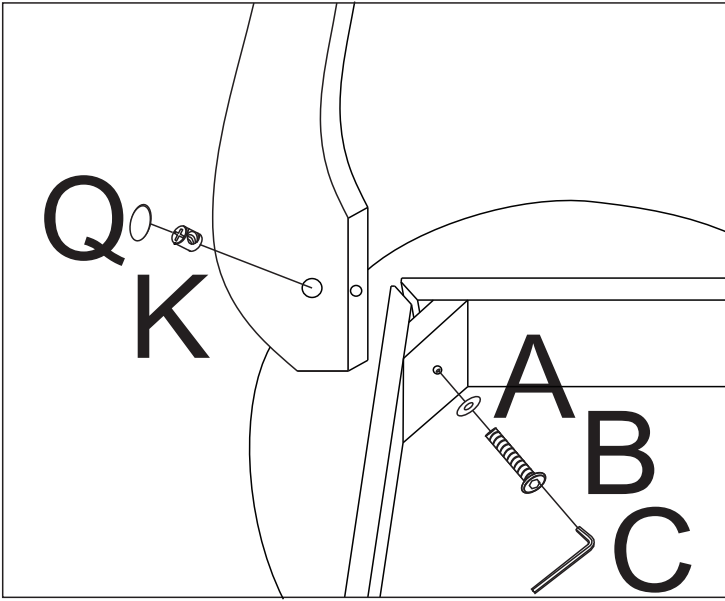

4

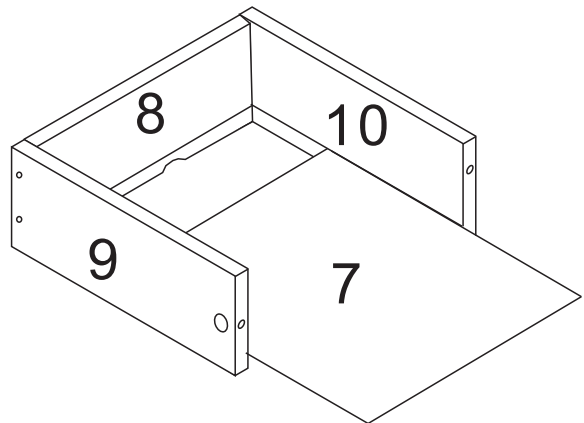
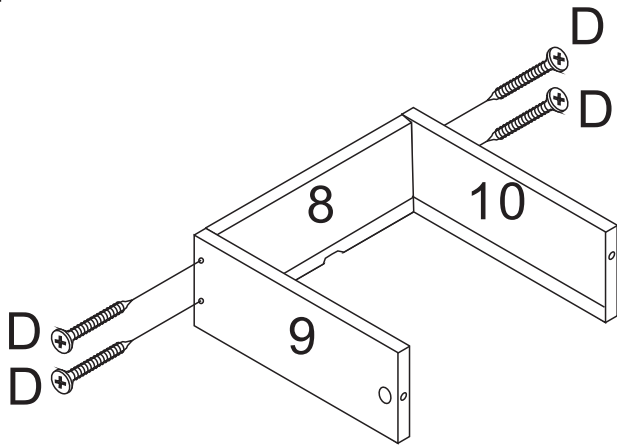

5

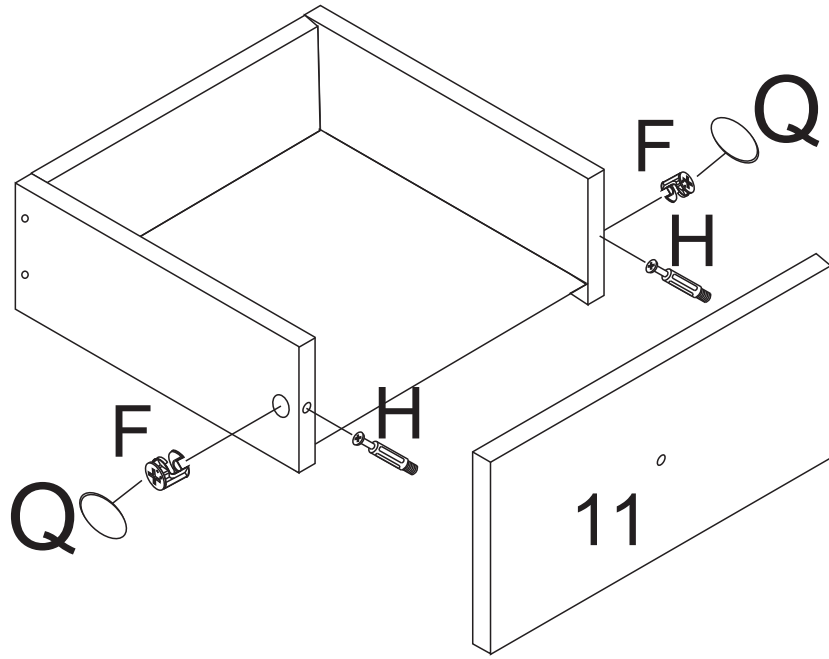

6

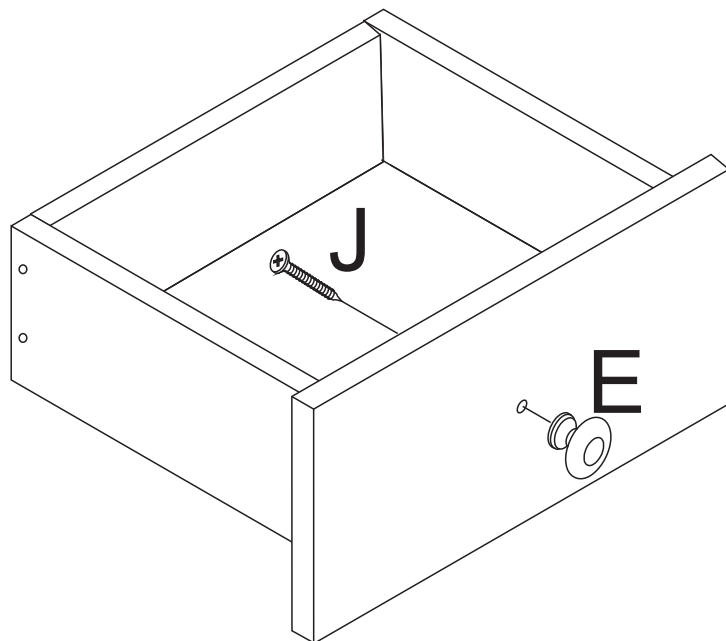

7

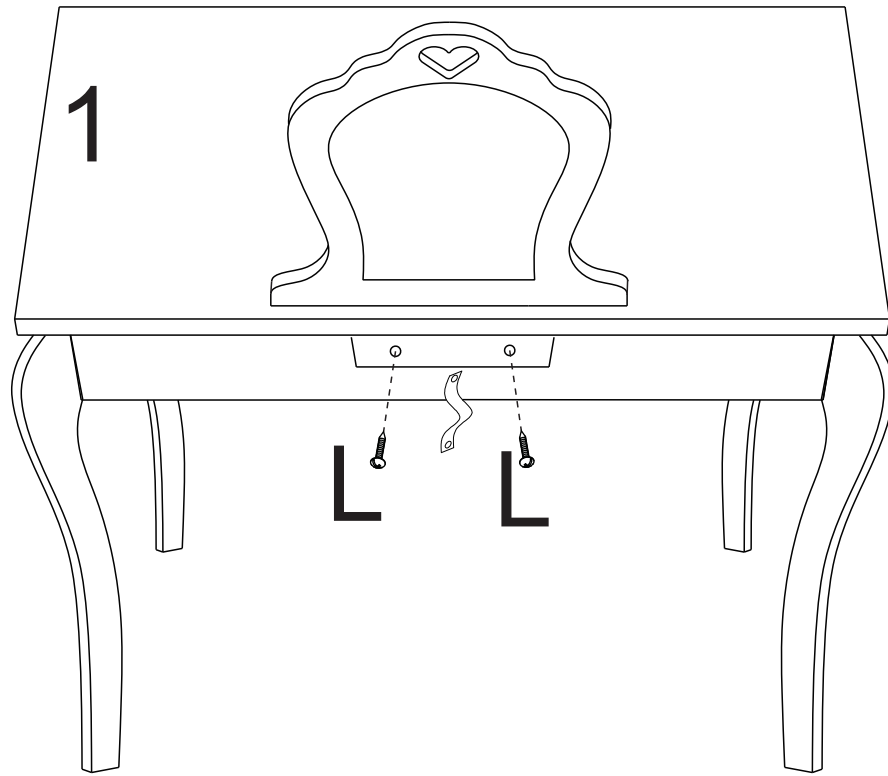

8

