

GLOBAL PROCUREMENT AND MARKETING LIMITED

PHOENIX SINGLE DOOR WARDROBE

Assembly instruction- Please keep for future reference

ROBPHO1 BK

ROBPHO1 OK

ROBPHO1 WT

ROBPHO1 GY

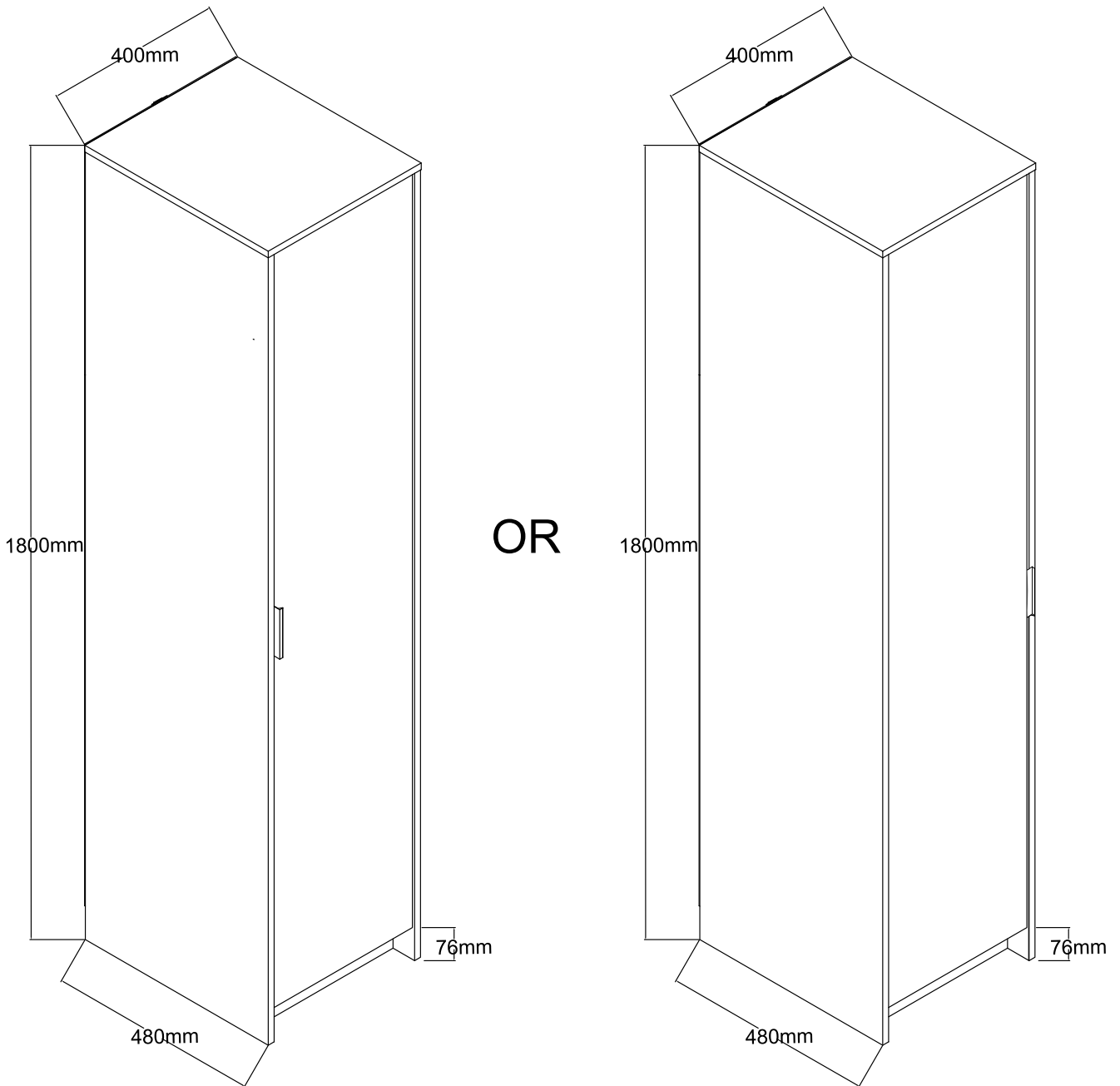

Dimensions	No. People	Assembly Time	OW#
Width: 40 cm		45 mins (approx)	ROBPHO1 BK
Depth: 48 cm			ROBPHO1 OK
Height: 180 cm			ROBPHO1 WT ROBPHO1 GY

thank you

For purchasing this
GPM Limited
product

Important

- PLEASE READ THESE INSTRUCTION FULLY BEFORE STARTING ASSEMBLY.
- PLEASE DO NOT THROW THE PACKAGING AWAY UNTIL YOU ARE SATISFIED WITH PURCHASE, GOODS NEED TO BE RETURNED IN ORIGINAL PACKAGING.

If you need help or have damaged or missing parts, please email aftersales@gpmfurniture.co.uk

⚠ Safety and Care Advice

Important-Please read these instructions fully before starting assembly

- Check you have all the components and tools listed on pages 2,3 and 4.
- Remove all fittings from the plastic bags and separate them into their groups.
- Keep children and animals away from the work area, small parts could choke if swallowed.
- Make sure you have enough space to lay out the parts before starting.
- Do not stand or put weight on the product, this could cause damage.
- Assemble the item as close to its final position (in the same room) as possible.
- Assemble on a soft, level surface to avoid damaging the unit or your floor.
- We do not recommend the use of power drill/drivers for inserting screw, as this could damage the unit. only use hand screwdrivers.
- Dispose of all packaging carefully and responsibly.



Care and Maintenance

- Only clean using a damp cloth and mild detergent, do not use bleach or abrasive cleaners.
- From time to time check that there are no loose screws on this unit.
- This product should not be discarded with household waste. Take to your local authority waste disposal centre.

If you are unhappy with the product and wish to return it, please following the retailer's returns procedure.

Components - Panels

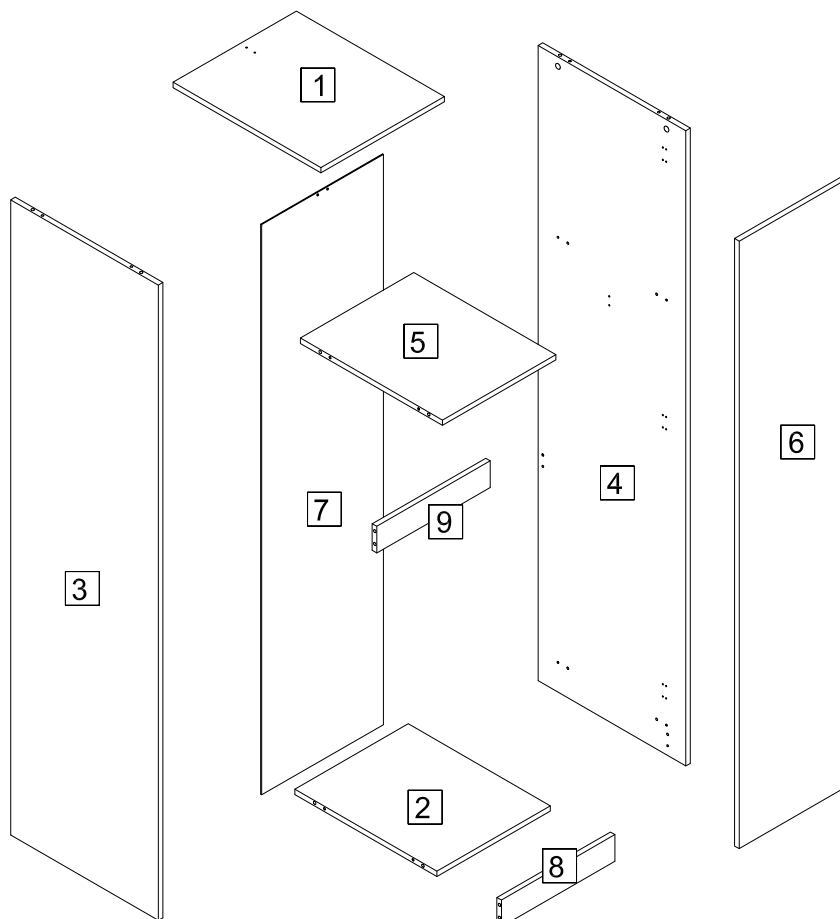







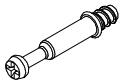

Components - Fixings

If you have damaged or missing components,
email: aftersales@gpmfurniture.co.uk

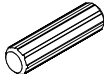

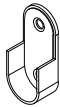
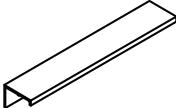
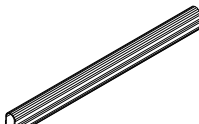

Please check that you have all the components listed below before constructing your item.

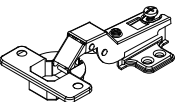
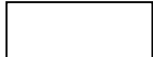
Note: The quantities below are the correct amount to complete the assembly. In some cases more fittings may be supplied than are required.

HARDWARE

<p>(A)</p>  <p>Cam Bolt M6x35mm X 20+2</p>	<p>(B)</p>  <p>Cam Lock M15x10mm X 20+2</p>	<p>(C)</p>  <p>Dowel M6x30mm X 12+1</p>	<p>(E)</p>  <p>M3x12mm X 2</p>	<p>(F)</p>  <p>Leg Pin X 4</p>
<p>(G)</p>  <p>M2.5X12mm X 22+2</p>	<p>(H)</p>  <p>Hanger Bracket X 2</p>	<p>(I)</p>  <p>Handle X 1</p>	<p>(N)</p>  <p>Hanger Rod x1</p>	<p>(O)</p>  <p>Button Head 14mm X 22+2</p>
<p>(P)</p>  <p>Hinges X 3</p>	<p>(Q)</p>  <p>Foot Pad x4</p>			

ANTI - TIPPING KITS

<p>(D)</p>  <p>M4x35mm X 1</p>	<p>(J)</p>  <p>M4X12mm X 2</p>	<p>(K)</p>  <p>M3.5x14mm X 1</p>	<p>(L)</p>  <p>Wall Plug X 1</p>	
---	---	---	---	--

Tools Required (Not Provided)



Ruler - Use this to measure your screws (mm)

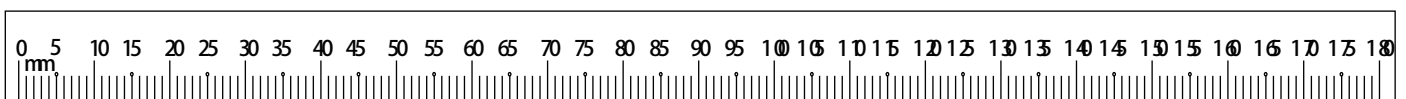

Important-Please read these instructions fully before starting assembly

If you need help or have damaged or missing parts, please email aftersales@gpmfurniture.co.uk

Assembly Instructions

If you have damaged or missing components,
email: aftersales@gpmfurniture.co.uk

Step 1

If the floor is tiled, please use leg pin (F).

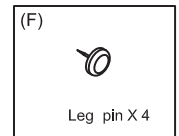
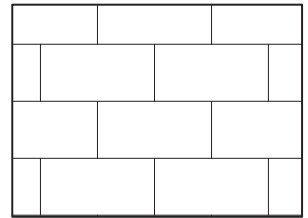
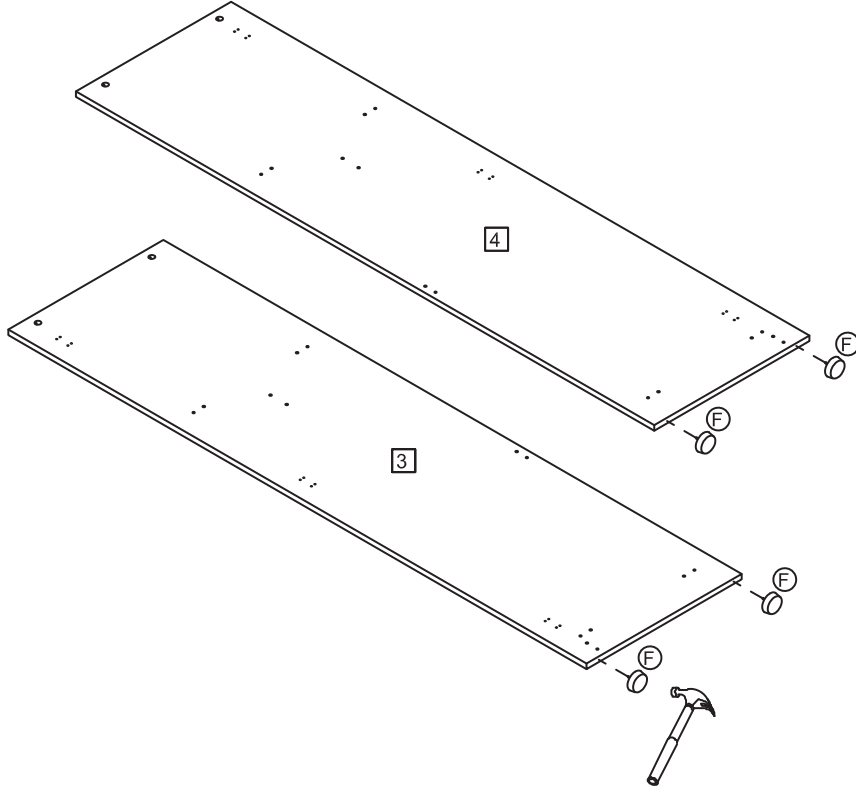

If the floor is wooden, please use foot pads (Q).

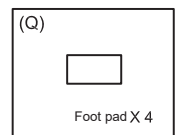
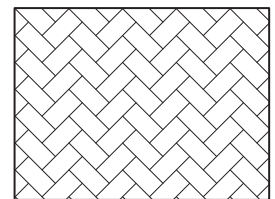
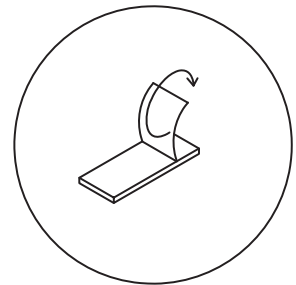
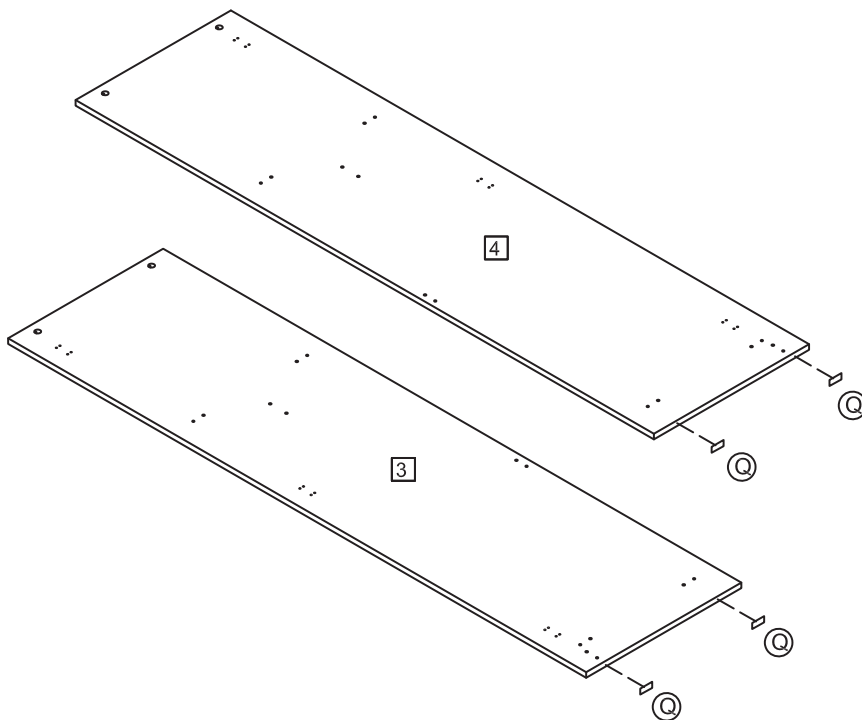

Step 2



Insert cam bolt (A) into corresponding holes in part 1, 3 & 4 as shown.

Attach hanger bracket (H) to part 3 & 4 with screw (O) as shown.

Attach leg pin (F) to the base of the wardrobe using small hammer.

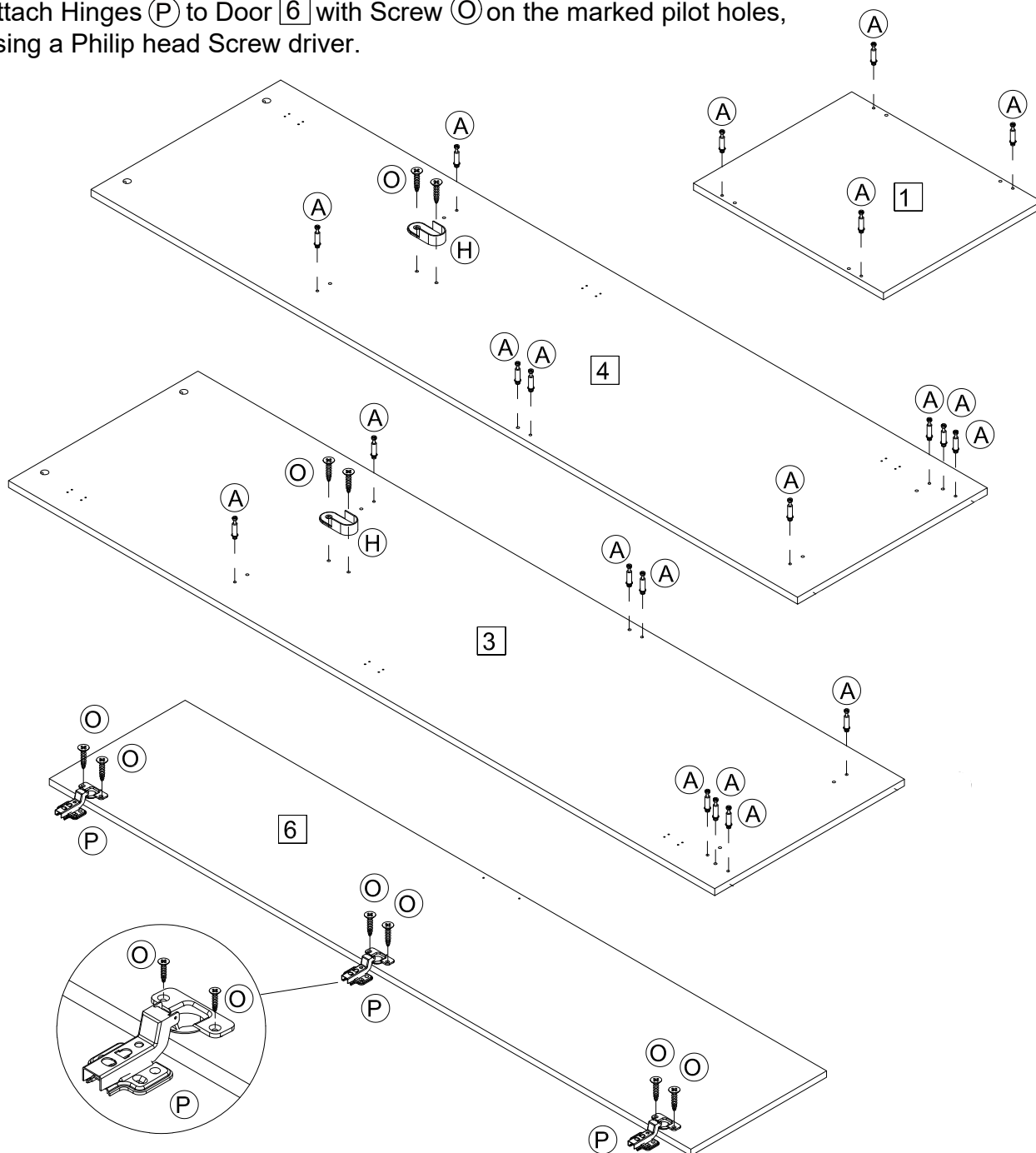
Attach Hinges (P) to Door 6 with Screw (O) on the marked pilot holes, using a Philip head Screw driver.

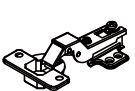

(A)	(O)	(H)	(P)
			
Cam Bolt M6x35mm X 20	Button Head 14mm X 10	Hanger Bracket X 2	Hinges X 3

Step 3

Insert wooden dowels C into part 4 as shown.

Add cam locks B into 2, 5, 8 and 9 as shown and attach 2, 5, 8 and 9 to part 4.

Turn cam locks clockwise to tighten.

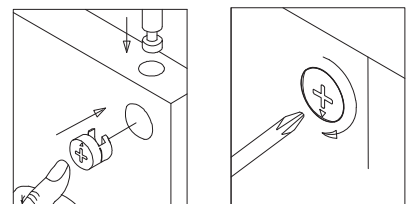
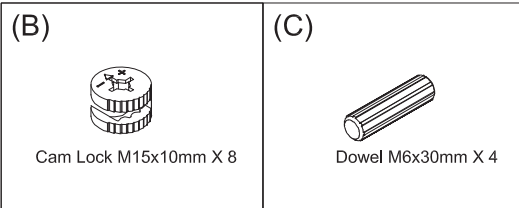
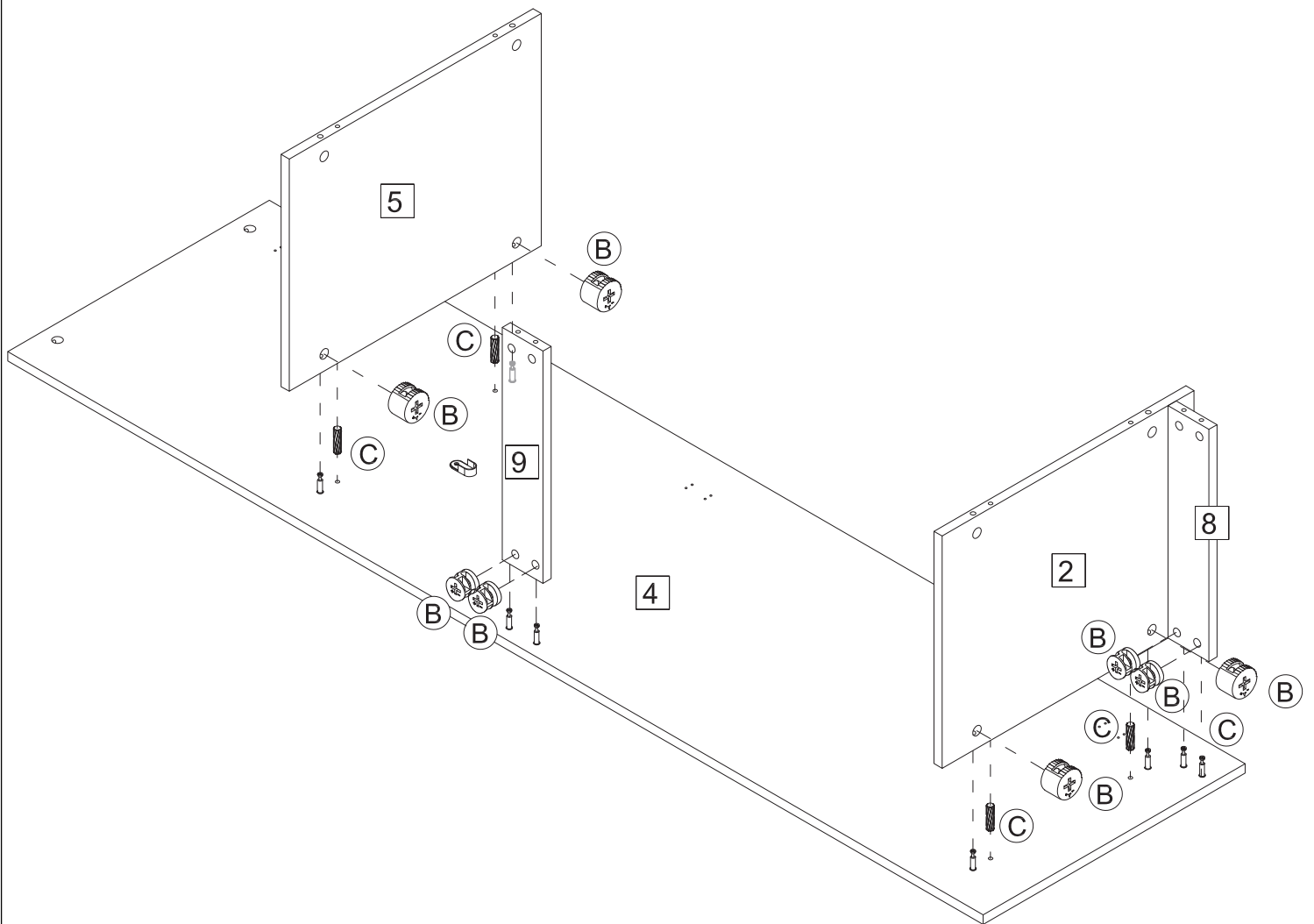

Step 4

Insert wooden dowels (C) into part [2], [5] and [8] as shown.

Add cam locks (B) into assembled unit as shown.

Attach part [3] to assembled unit.

Turn cam locks clockwise to tighten.

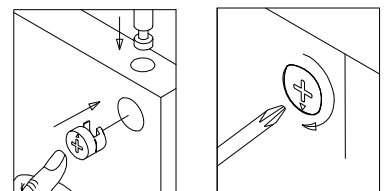
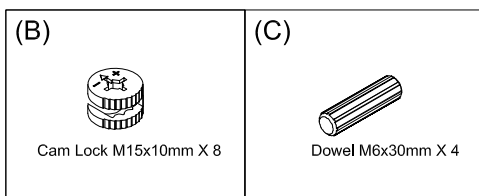
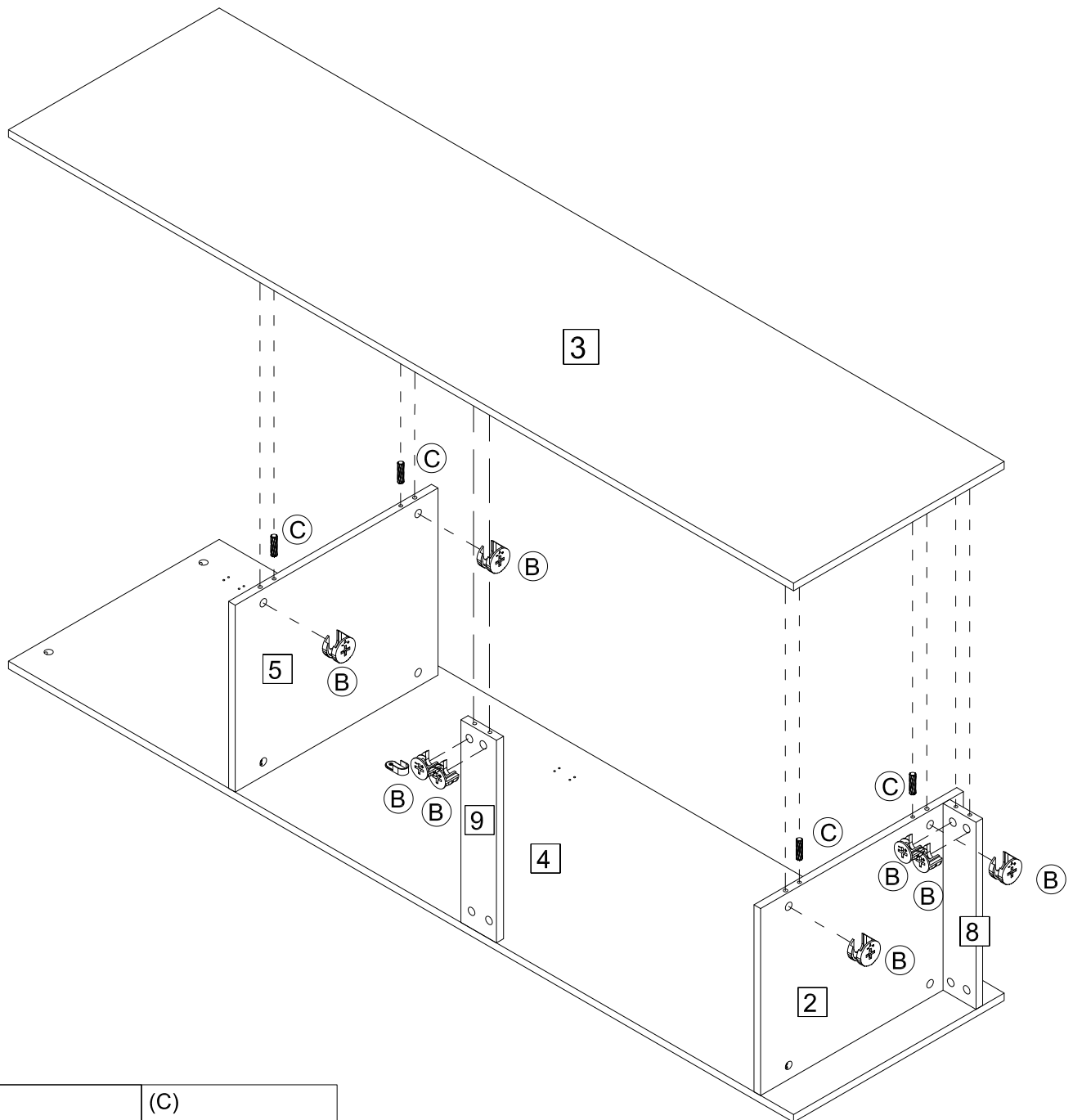

Step 5

Insert wooden dowels (C) and cam locks (B) into part 3 and 4 as shown.

Attach part 1 to assembled unit. Turn cam locks clockwise to tighten.

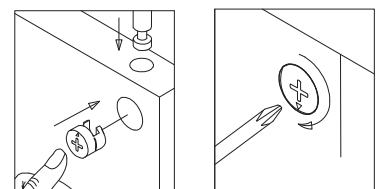
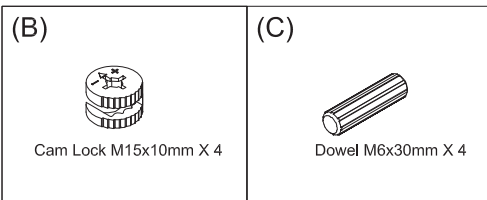
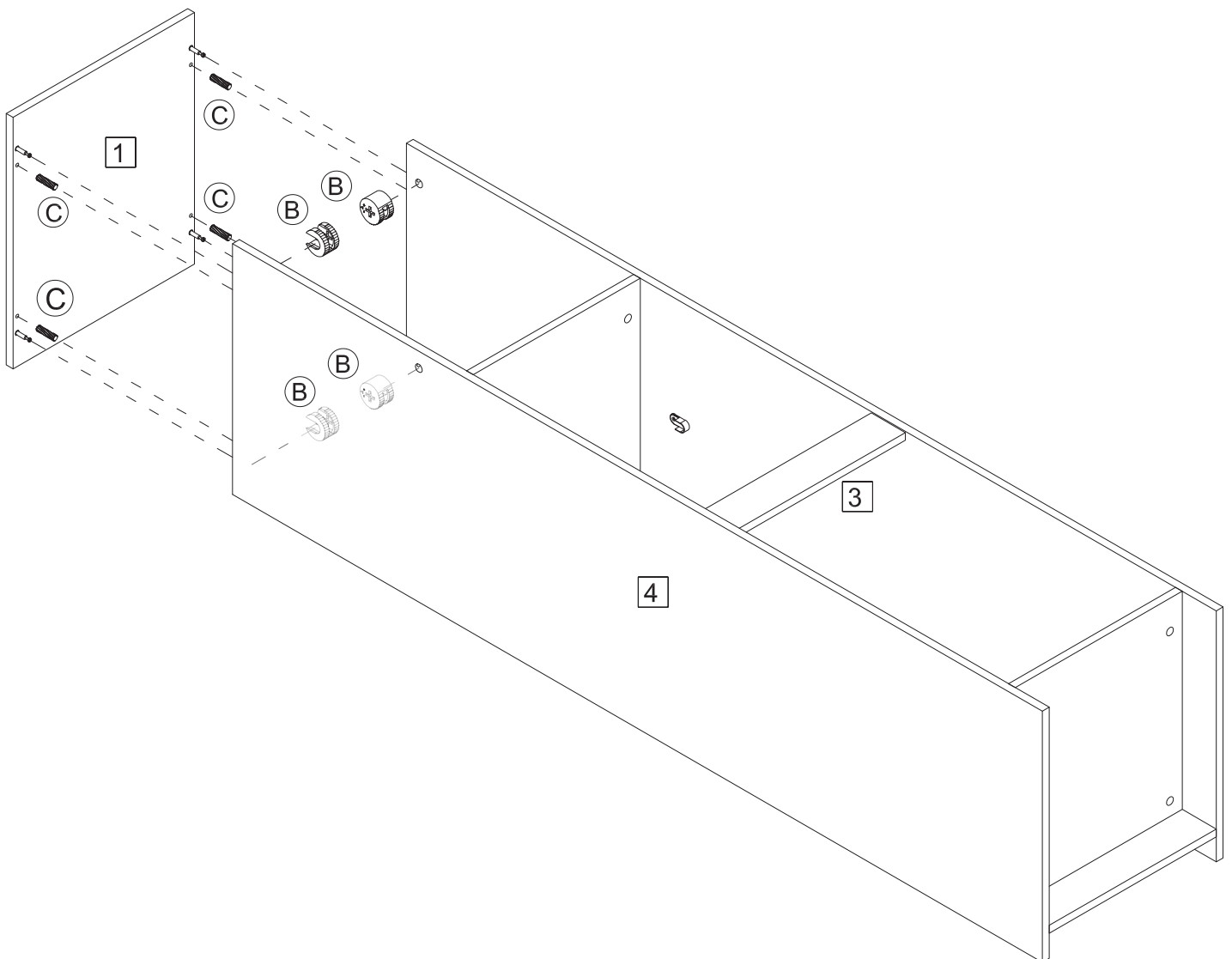

Step 6

Attach back board **7** to the back of the wardrobe with screw **(G)**

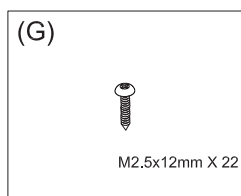
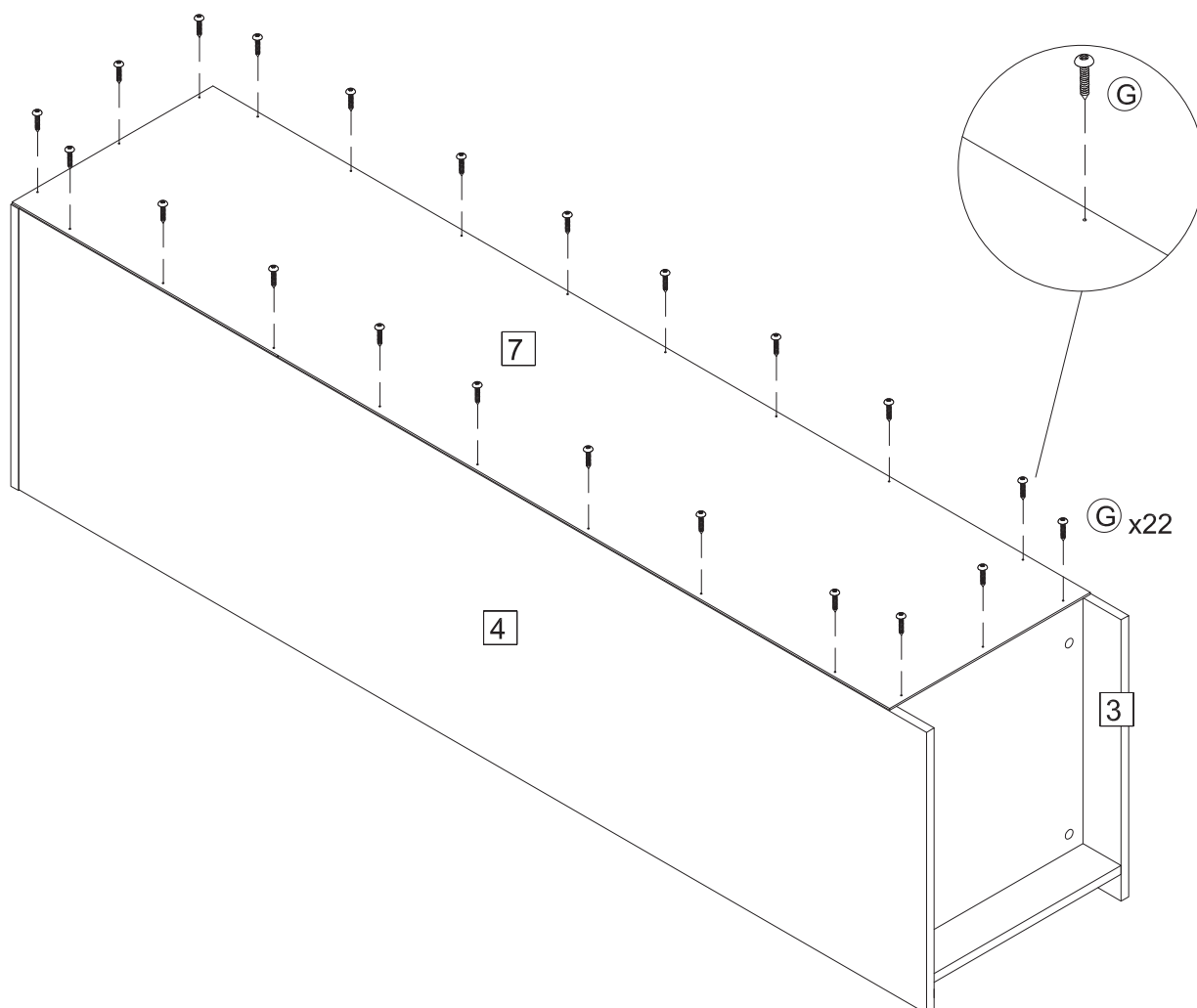

Step 7

Door on the left

Attach Hinges (P) on Door (6) to Part (3) side board with Screw (O) on the marked pilot holes, using a Philip head Screw driver.

Attach door handle (I) with Screw (E) using a Philip head Screw driver.

Attach hanger rod (N) to hanger bracket (H) as shown.

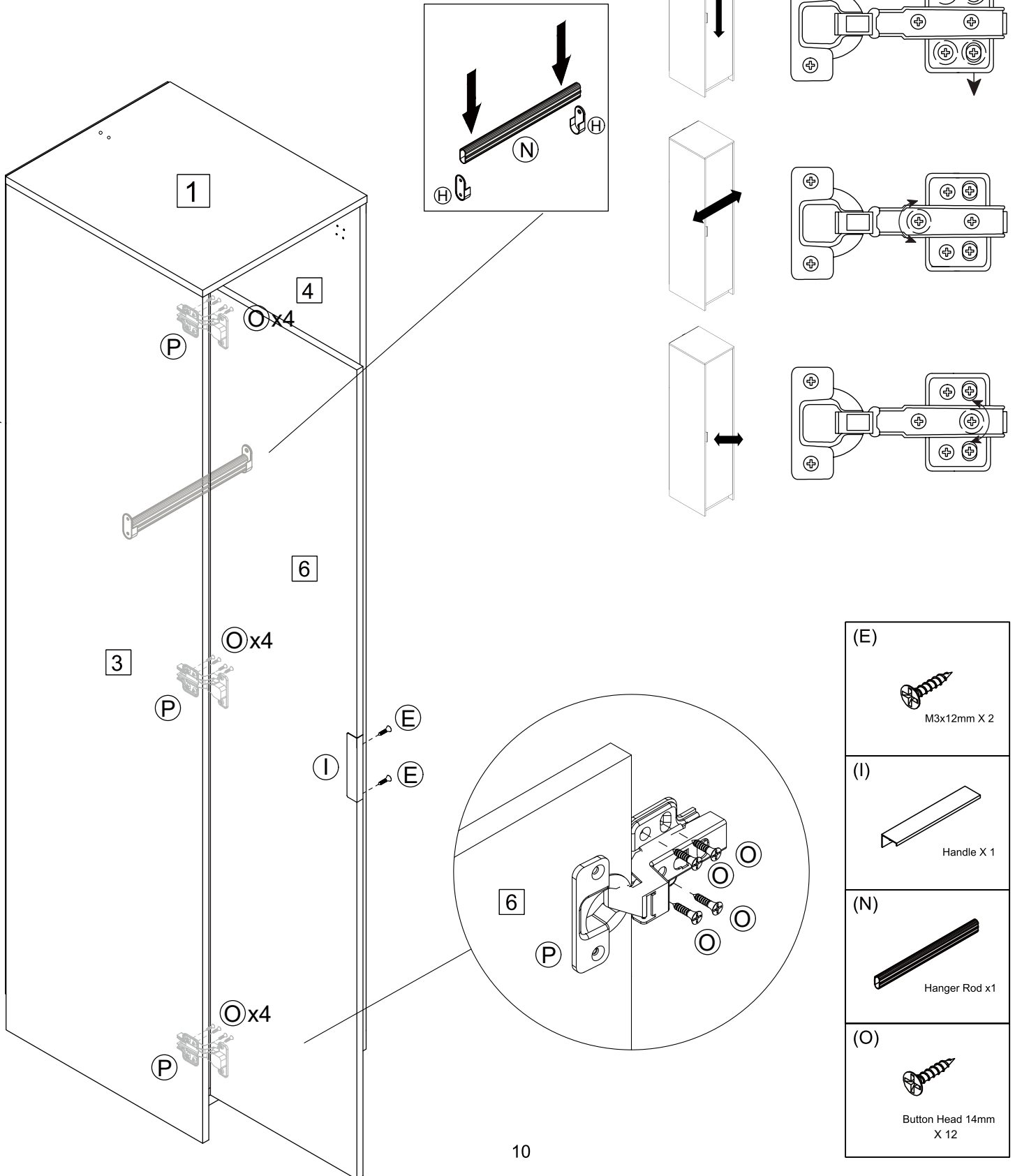

Step 8

Door on the right.

Attach Hinges (P) on Door (6) to Part (4) side board with Screw (O) on the marked pilot holes, using a Philip head Screw driver.

Attach door handle (I) with Screw (E) using a Philip head Screw driver.

Attach hanger rod (N) to hanger bracket (H) as shown.

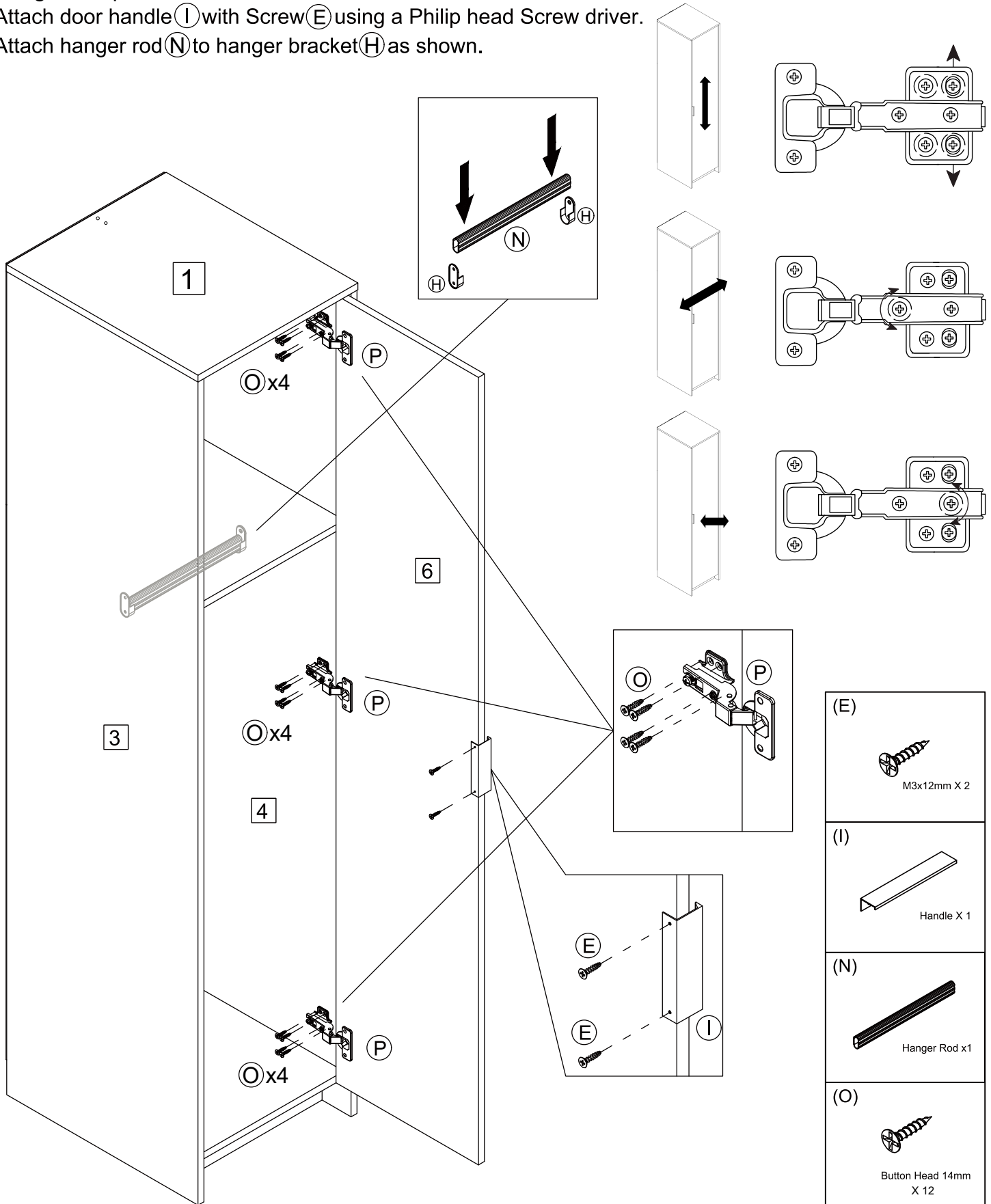

Step 9

Attach the Anti-Tipping kit to the wall, following the steps as shown.

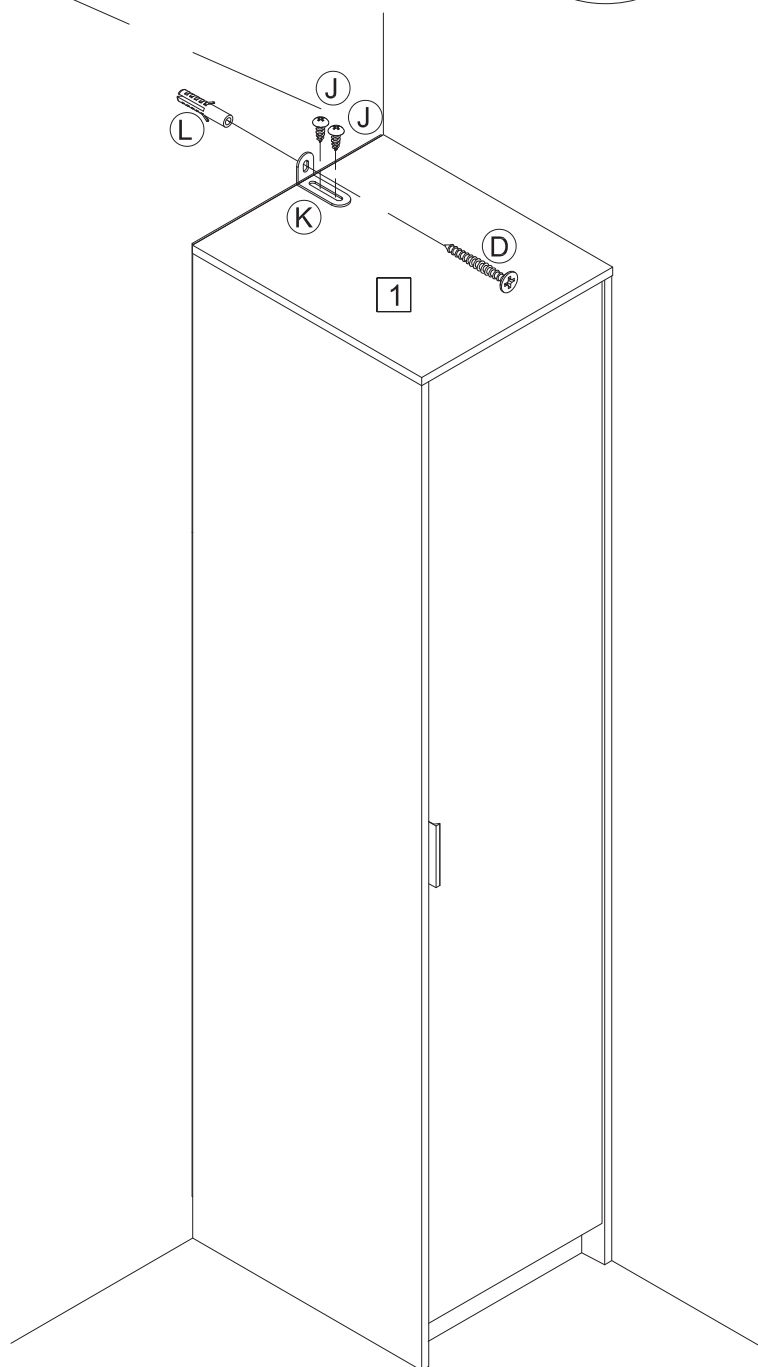
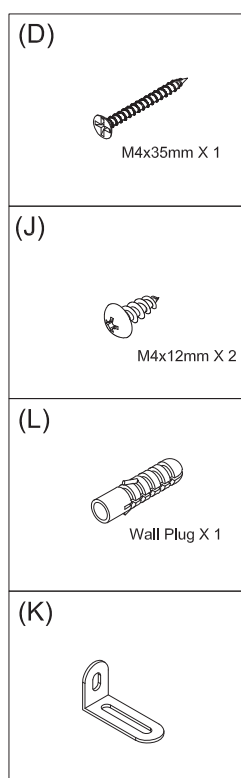
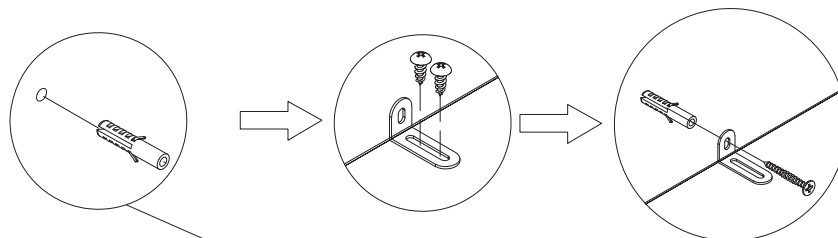

Assembly complete