

GOLBAL PROCUREMENT AND MARKETING LIMITED

PHOENIX 6 DRAWER WIDE CHEST

Assembly instruction- Please keep for future reference

CHTPHO6BK

CHTPHO6OK

CHTPHO6WT

CHTPHO6GY

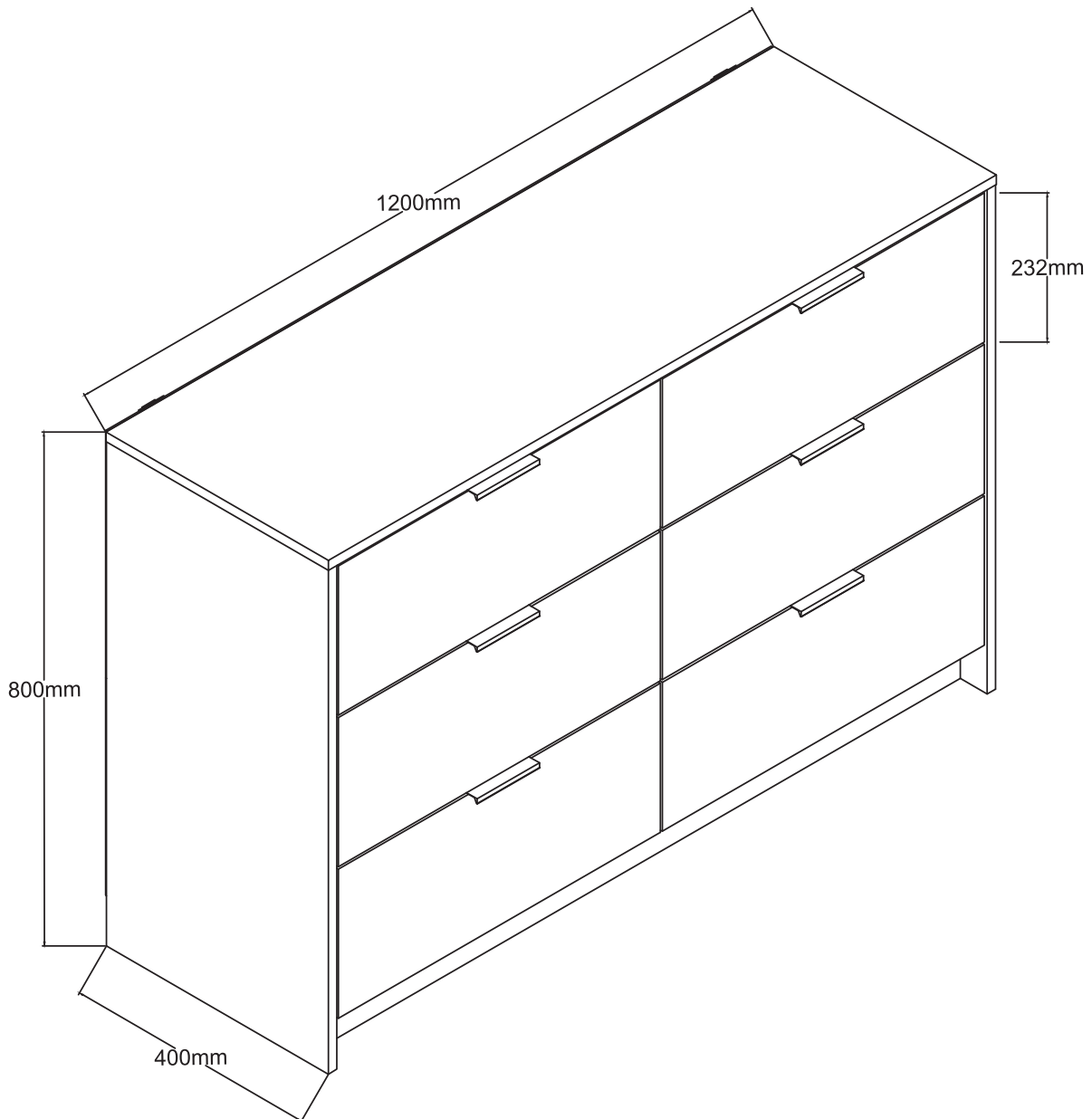

Dimensions	No. People	Assembly Time	OW#
Width: 120 cm		90 mins (approx)	CHTPHO6BK
Depth: 40 cm			CHTPHO6OK
Height: 80 cm			CHTPHO6WT
			CHTPHO6GY

thank you

For purchasing this
GPM Limited
product

Important-Please read these instructions fully before starting assembly

If you need help or have damaged or missing parts, please email aftersales@gpmfurniture.co.uk

⚠ Safety and Care Advice

Important-Please read these instructions fully before starting assembly

- Check you have all the components and tools listed on pages 2,3 and 4.
- Remove all fittings from the plastic bags and separate them into their groups.
- Keep children and animals away from the work area, small parts could choke if swallowed.
- Make sure you have enough space to lay out the parts before starting.
- Do not stand or put weight on the product, this could cause damage.
- Assemble the item as close to its final position (in the same room) as possible.
- Assemble on a soft, level surface to avoid damaging the unit or your floor.

- We do not recommend the use of power drill/drivers for inserting screw, as this could damage the unit. only use hand screwdrivers.
- Dispose of all packaging carefully and responsibly.



Care and Maintenance

- Only clean using a damp cloth and mild detergent, do not use bleach or abrasive cleaners.
- From time to time check that there are no loose screws on this unit.
- This product should not be discarded with household waste. Take to your local authority waste disposal centre.

If you are unhappy with the product and wish to return it, please following the retailer's returns procedure.

Components - Panels

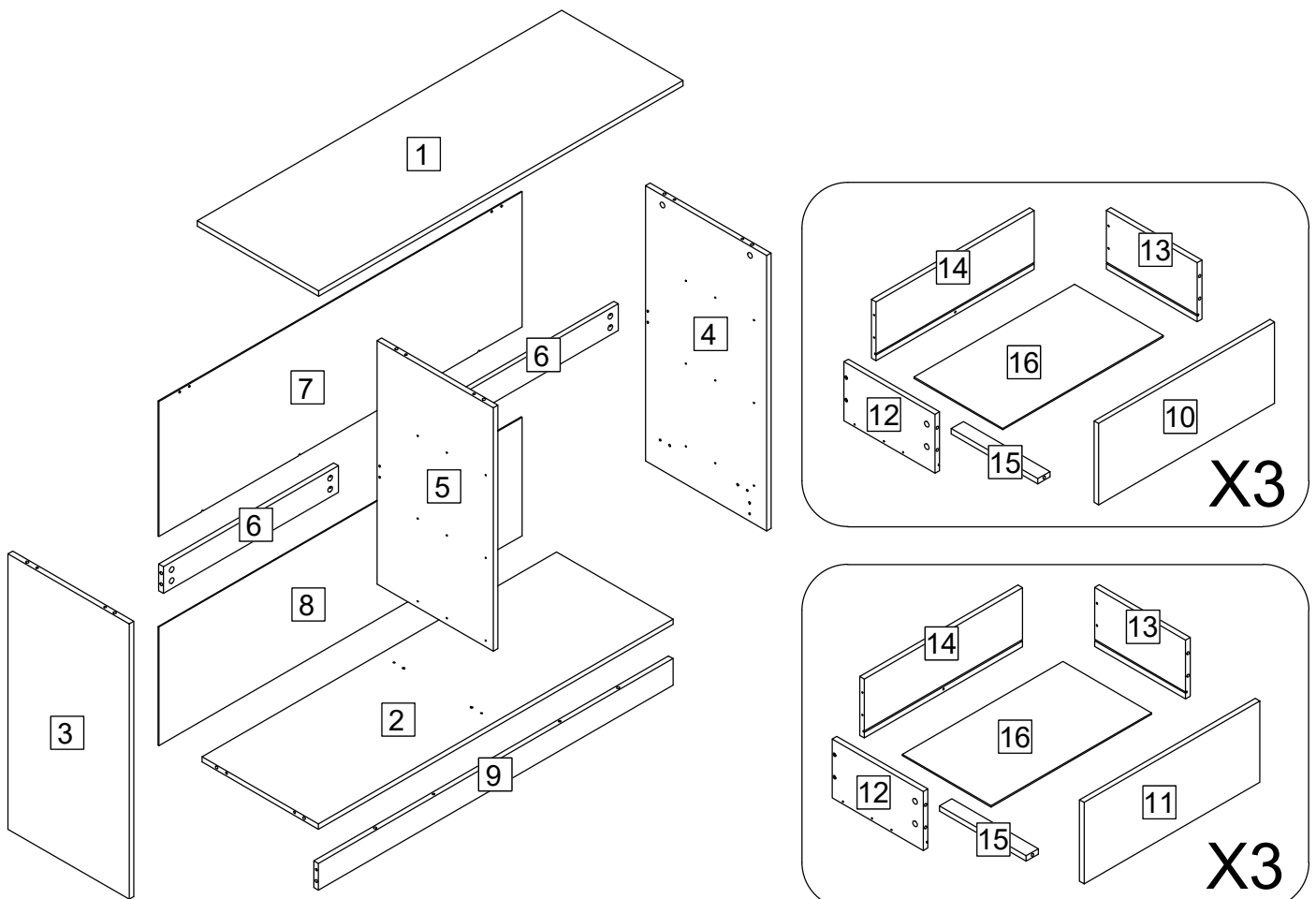











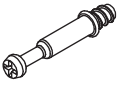

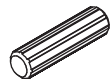
Components - Fixings

If you have damaged or missing components,
email: aftersales@gpmfurniture.co.uk

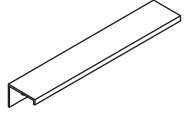

Please check that you have all the components listed below before constructing your item.

Note: The quantities below are the correct amount to complete the assembly. In some cases more fittings may be supplied than are required.

HARDWARE

(A)  Cam Bolt M6x35mm X 52	(B)  Cam Lock M15x10mm X 52	(C)  Dowel M6x30mm X 16	(D)  M4x35mm X 36	(E)  M3x12mm X 84
(F)  Leg Pin X 5	(G)  Nail X 26	(H)  Backboard screws M2.5x14mm X 4	(I)  Handle X 6	
(CL)  Drawer Slide X 6	(CR)  Drawer Slide X 6	(DL)  Drawer Slide X 6	(DR)  Drawer Slide X 6	

ANTI - TIPPING KITS

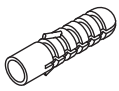
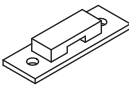
(J)  Strap X 2	(K)  M3.5x14mm X 4	(L)  Wall Plug X 4	(M)  Bracket X 4
---	---	---	---

Tools Required (Not Provided)



Ruler - Use this to measure your screws (mm)

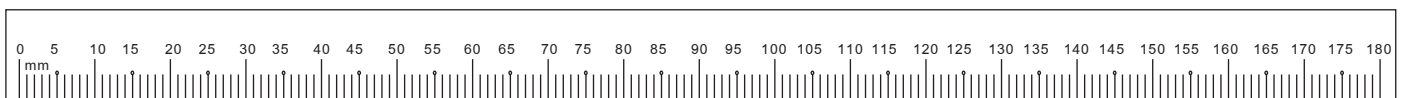

Important-Please read these instructions fully before starting assembly

If you need help or have damaged or missing parts, please email aftersales@gpmfurniture.co.uk

Assembly Instructions

If you have damaged or missing components,
email: aftersales@gpmfurniture.co.uk

Step 1

Attach drawer slide rail (CL) & (CR) to Panel boards 3, 4 & 5 with screw (E) onto the specific pre-drilled pilot holes as shown below.

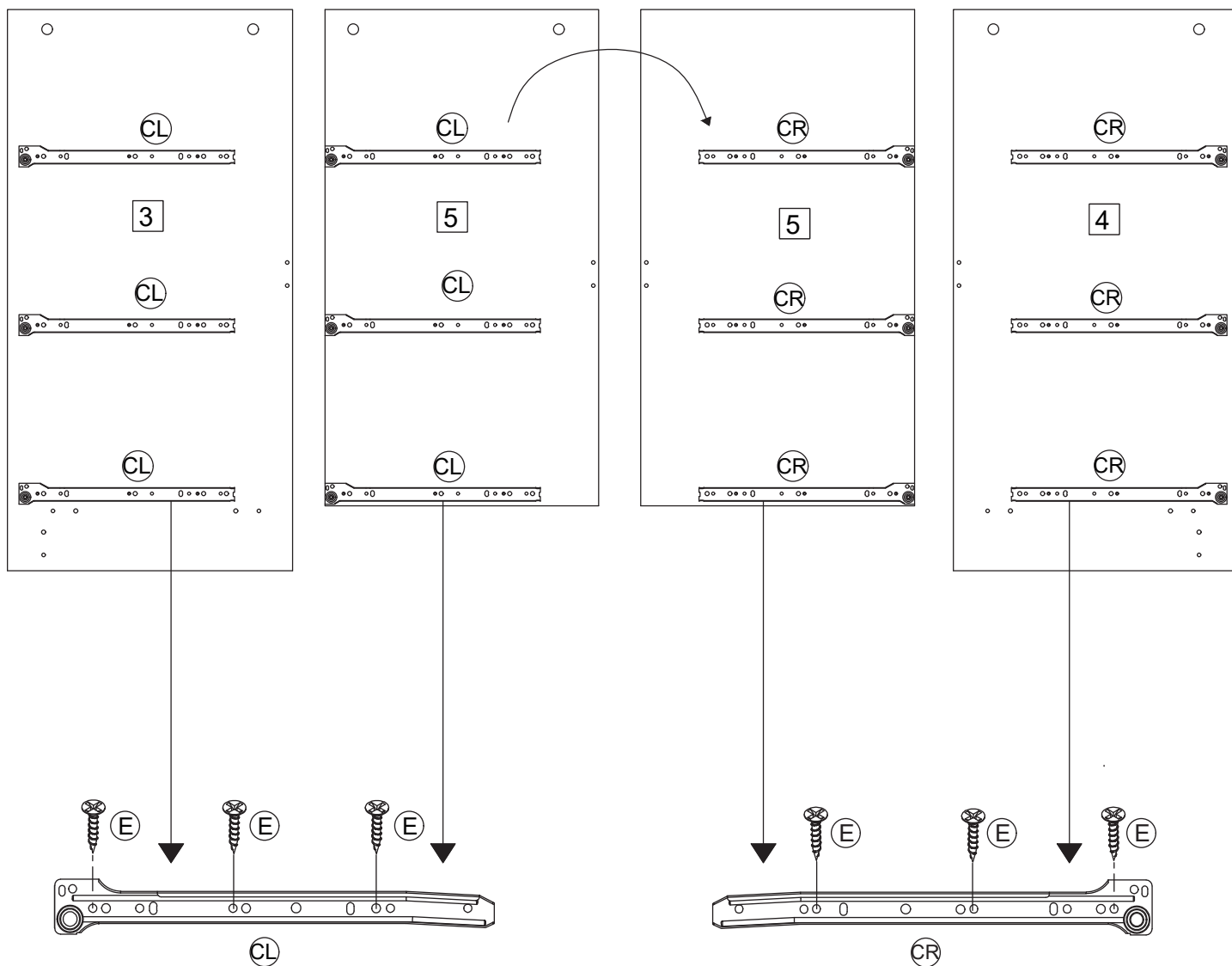

(E)	(CL)	(CR)
M3x12mm X 36	Drawer Slide X 6	Drawer Slide X 6

Step 2

Insert cam bolt (A) into corresponding holes in part 1, 2, 3, 4 & 5 as shown.

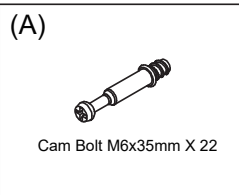
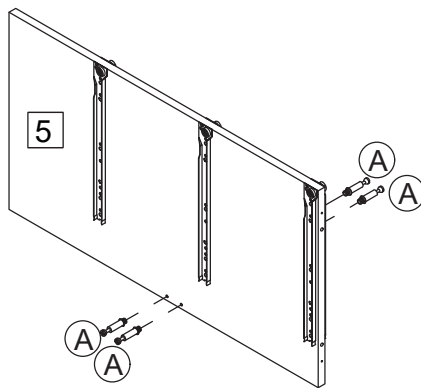
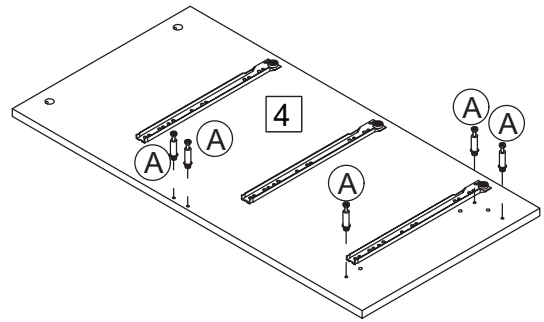
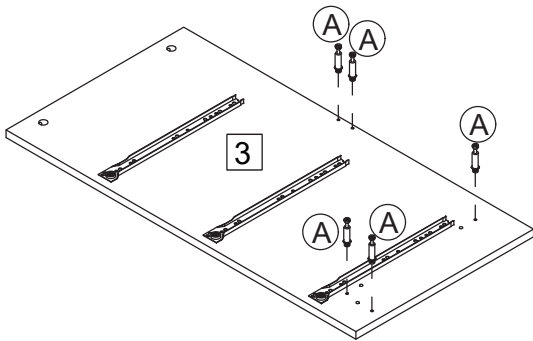
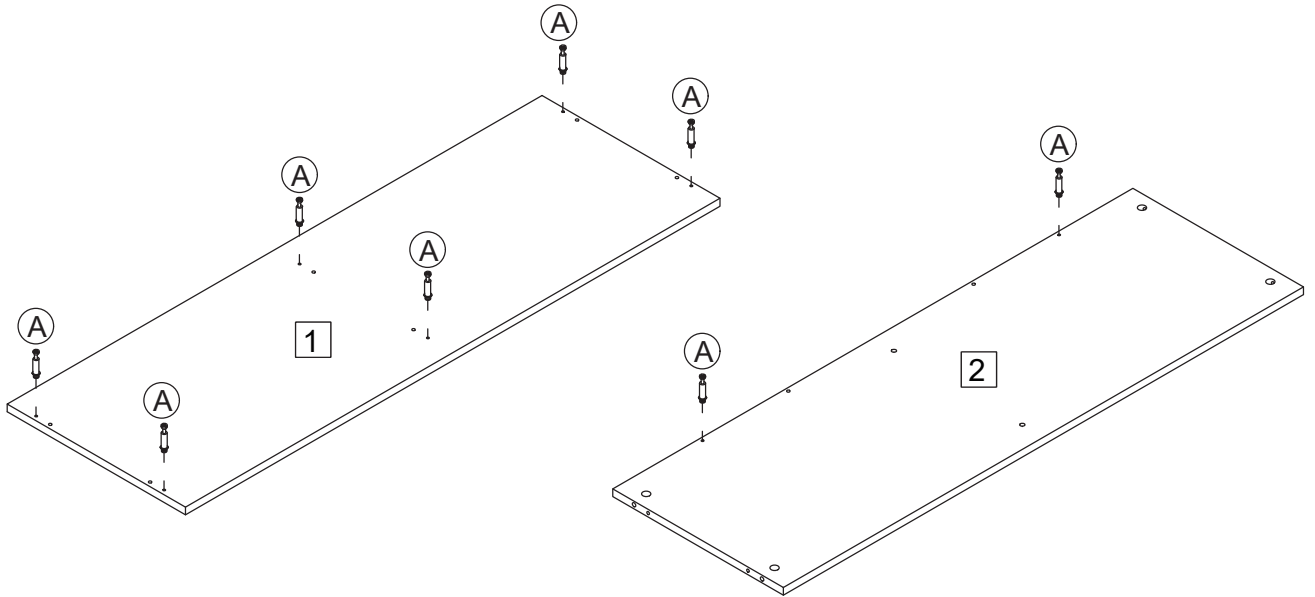

Step 3

Insert cam locks (B) to parts (6). Attach part (5) as shown.
Turn cam locks clockwise to tighten.

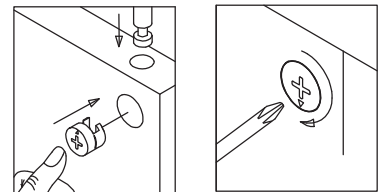
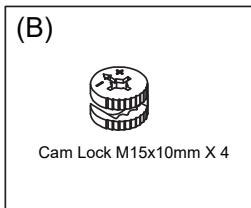
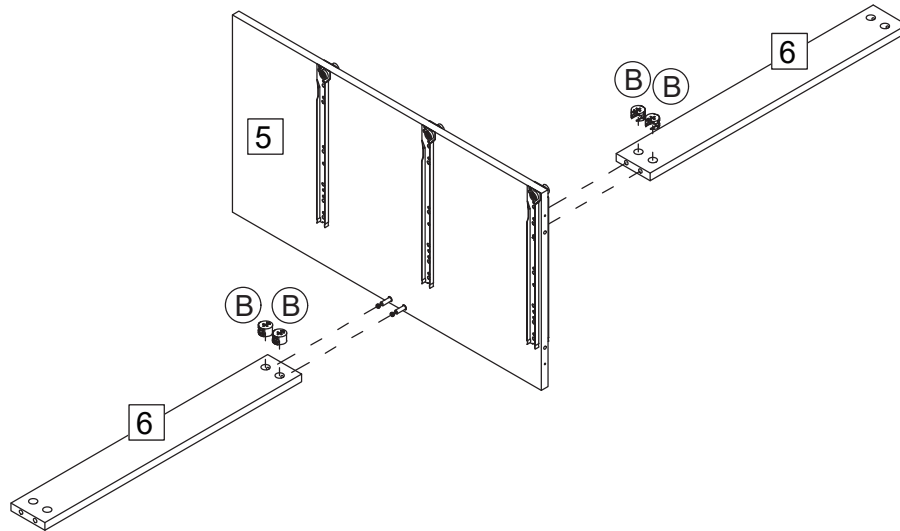

Step 4

Insert wooden dowels (C) into part (2) as shown.
Add cam locks (B) into part (9) as shown
and attach part (9) to (2).
Turn cam locks clockwise to tighten.

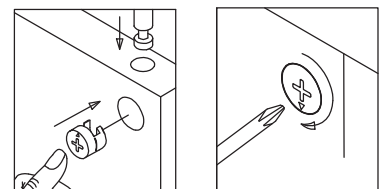
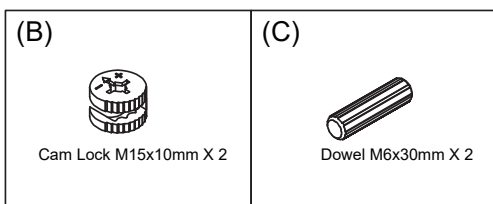
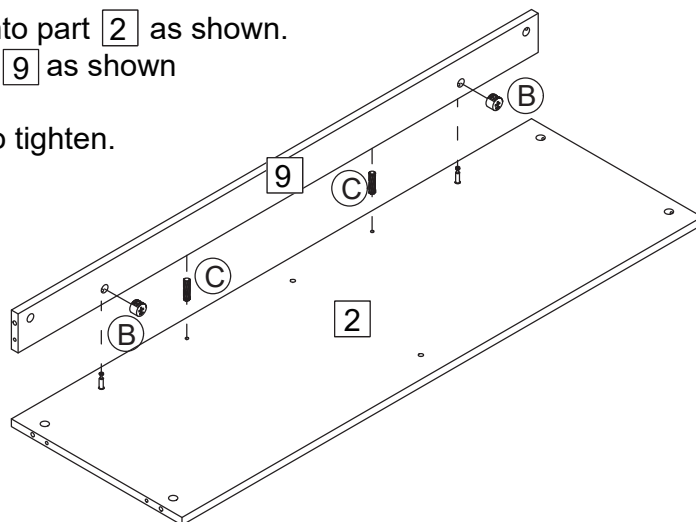

Step 5

Insert wooden dowels (C) into part (5) as shown.
Attach part (2) to part (5) using screws (D) as shown

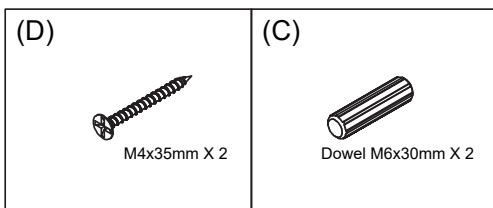
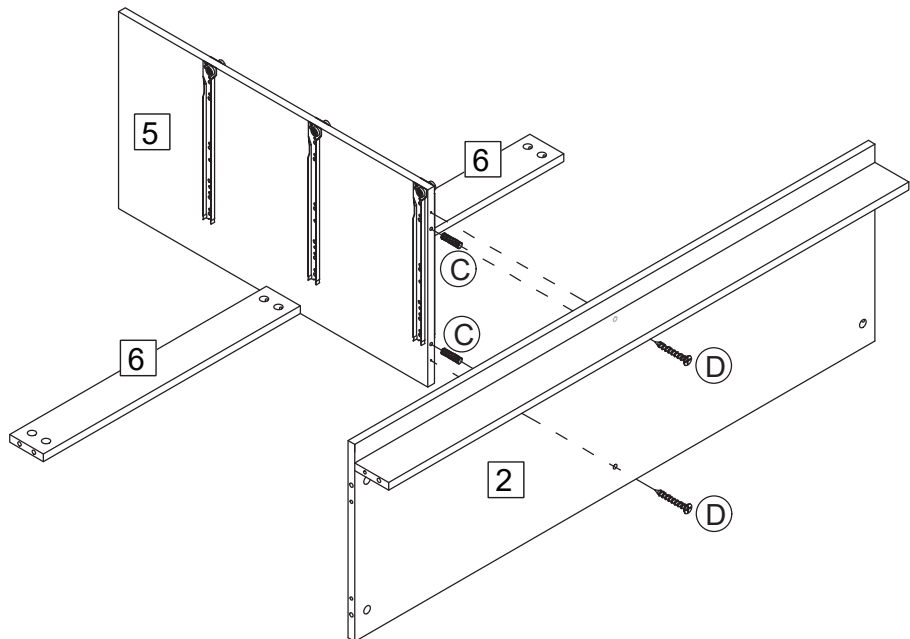

Step 6

Insert wooden dowels (C) into part (2) and (9) as shown.
Add cam locks (B) into part (2), (6) and (9) as shown and attach part (3) to assembled unit. Turn cam locks clockwise to tighten.

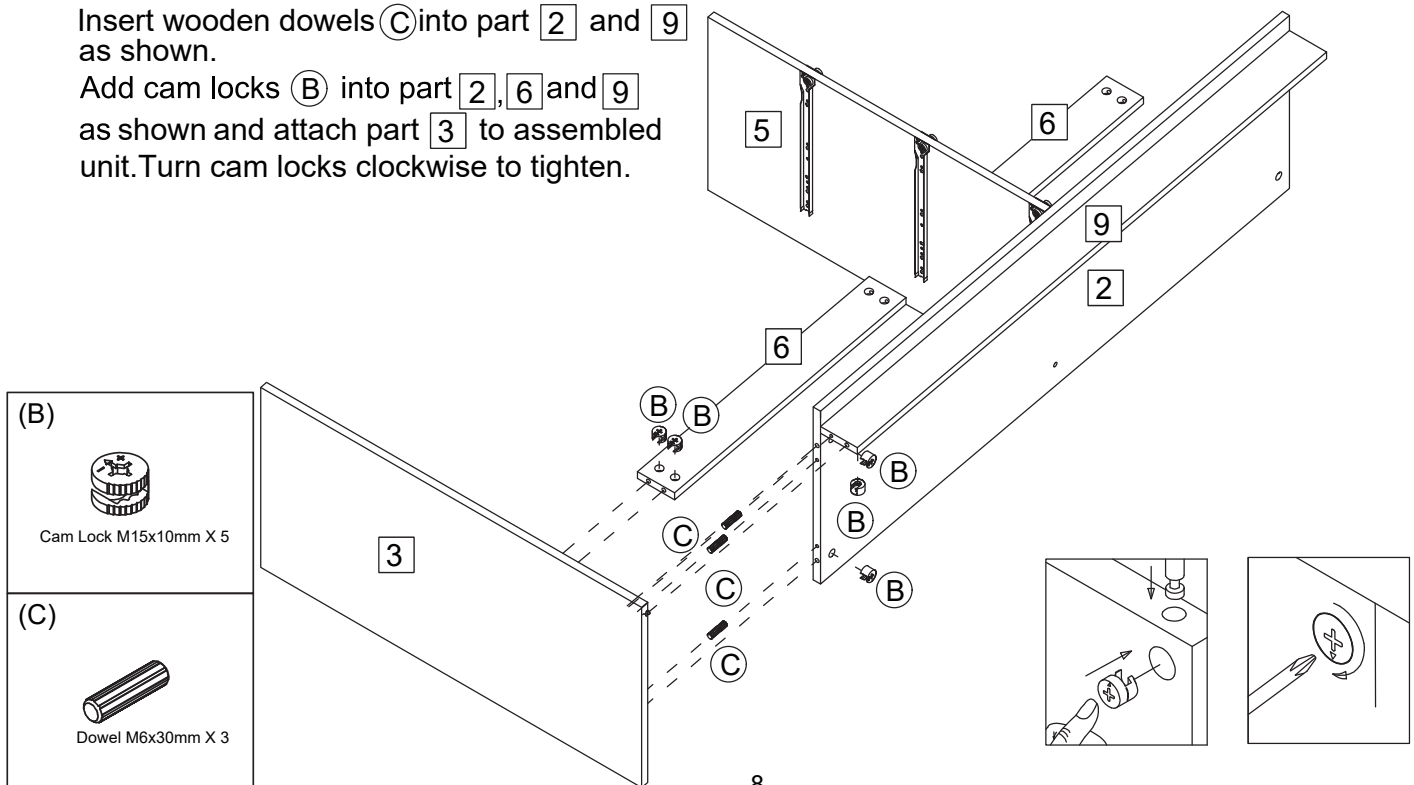

Step 9

Insert wooden dowels (C) and cam locks (B) into part 3, 4 and 5 as shown.
Attach part 1 to assembled unit. Turn cam locks clockwise to tighten.

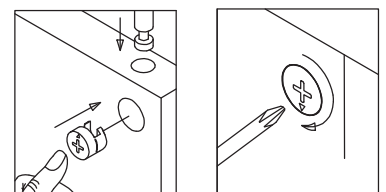
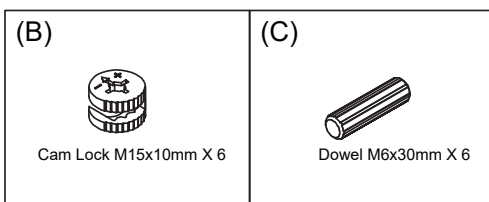
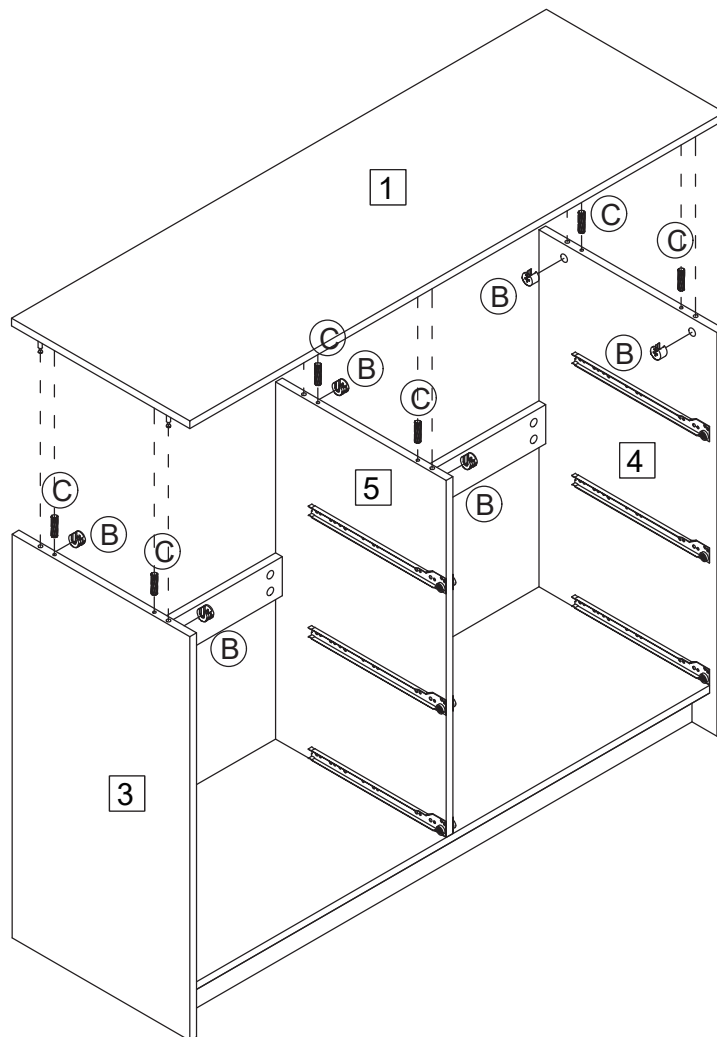



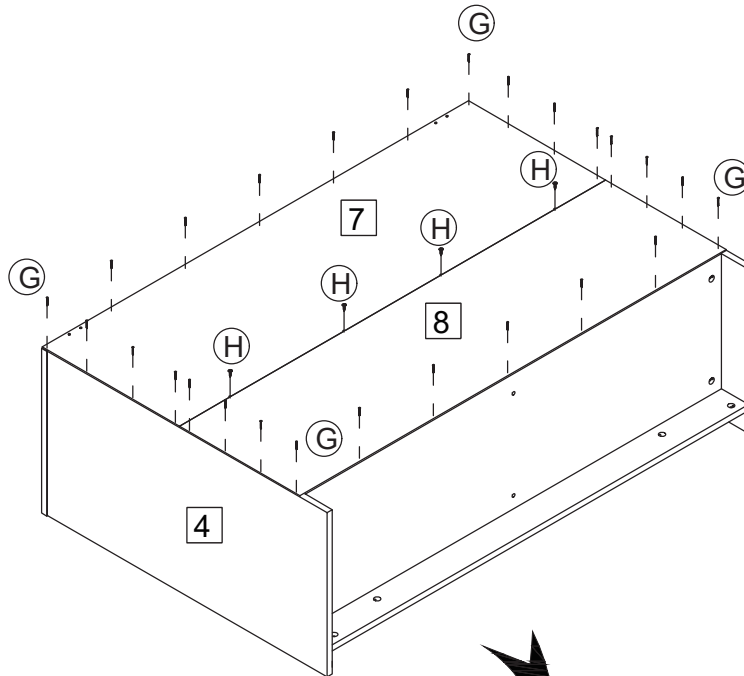

Step10

Attach back board **7** and **8** to the back of chest, with nail **(G)** using a small hammer.
Fix the middle with screws **(H)**.

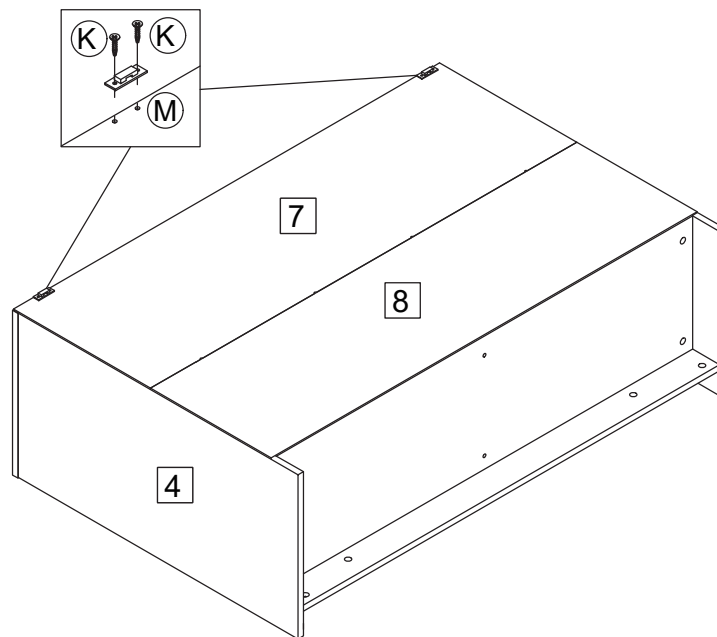

Attach Anti tipping kit **(M)** with **(K)** at the back of the chest as shown.

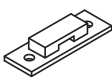

(G)	(H)
 Nail X 26	 Backboard screws X 4
(K)	(M)
 M3.5x14mm X 4	 Bracket X 2

Step 11

Attach parts **12** and **13** and **15** to part **14** by using screws **(D)** as shown.

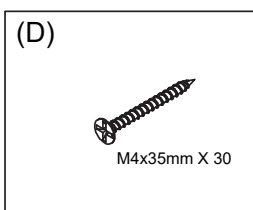
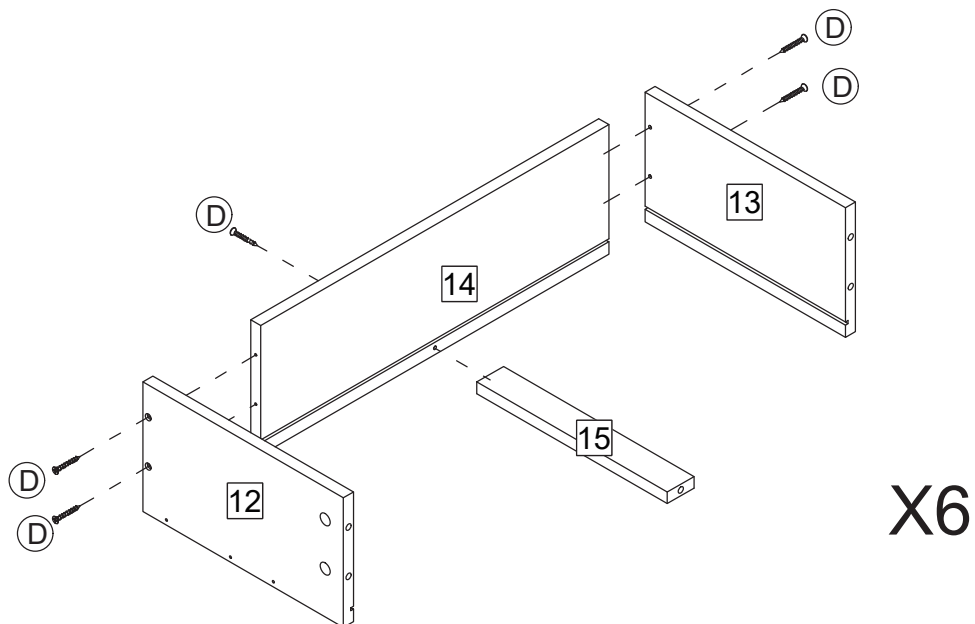

Step 12

Slide part **16** into available slots of parts **12** and **13** as shown.

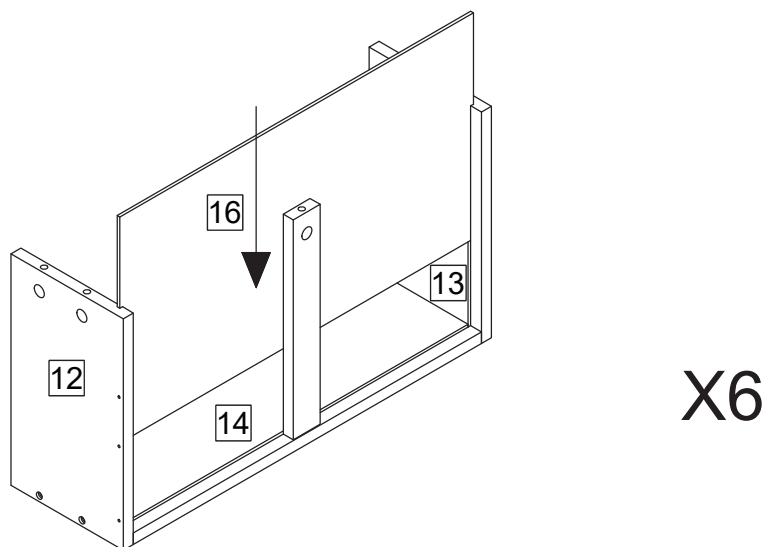

Step 13

Insert cam bolt (A) into corresponding holes in parts 10 and 11 as shown.

Fix handle (I) to part 10 and 11 using screw (E), as shown. Do not use an electric screwdriver, do not use force during the rotation of the accessories, otherwise it may cause the board to crack

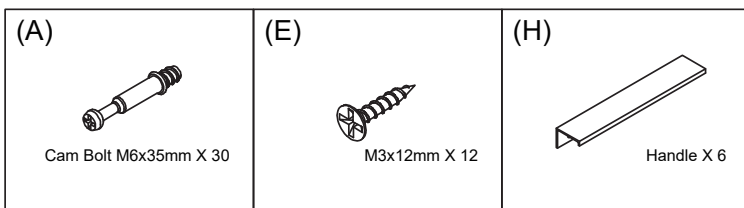
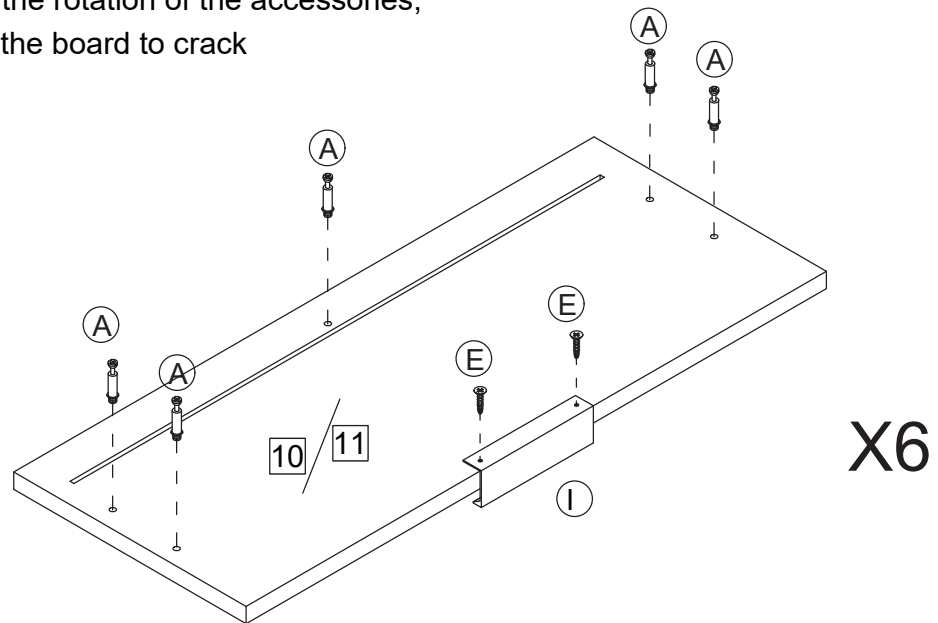

Step 14

Insert cam locks (B) to parts 12 and 13 and attach part 10 and 11 as shown.

Turn cam locks clockwise to tighten.

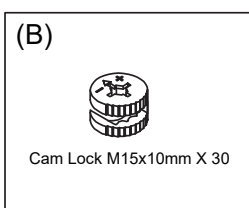
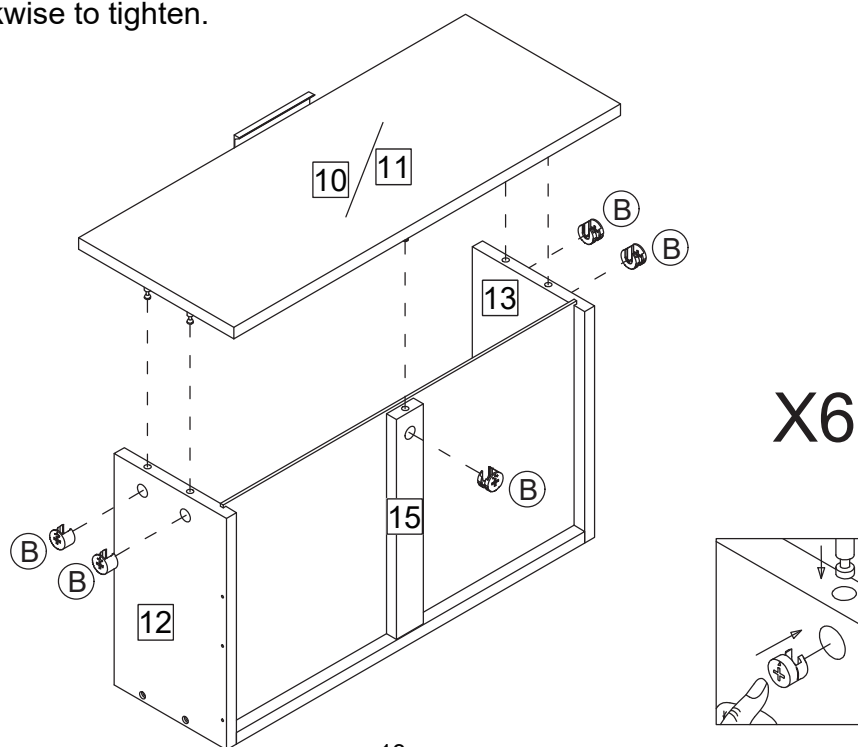

Step 15

Fix left inner drawer runner (DL) to part 12 and fix right inner drawer runner (DR) to part 13 by using screws (E) as shown.

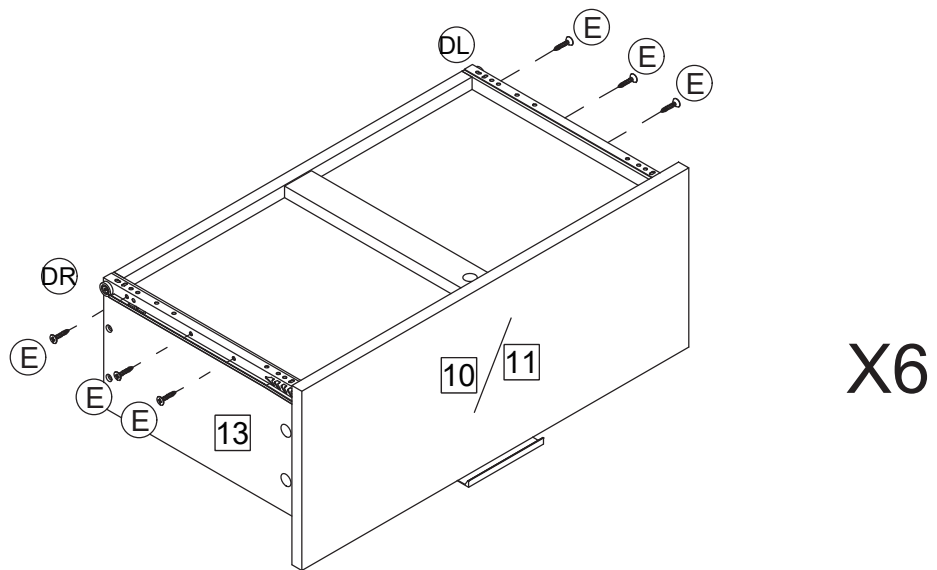

(E)	(DL)	(DR)
M3x12mm X 36	Drawer Slide X 6	Drawer Slide X 6

Step 16

Slide in drawers into the chest carcass frame with the drawer front panel marked 10 on the left side of the chest and 11 on the right side of the chest.

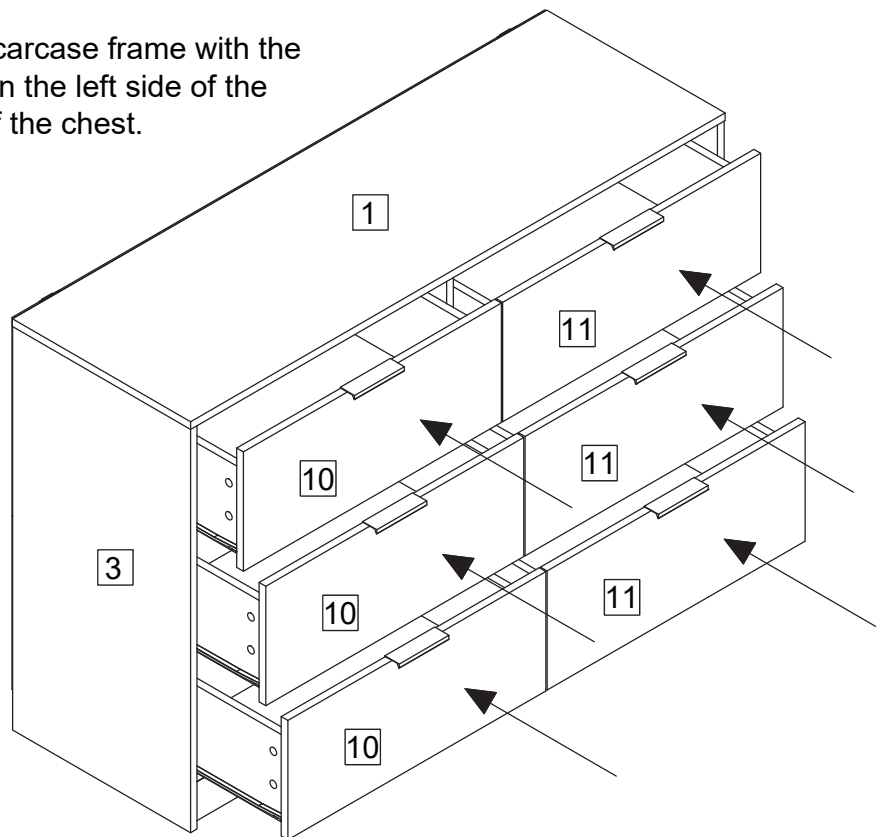
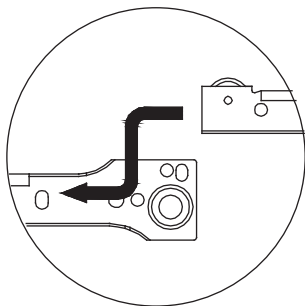

Step 17

Attach the Anti-Tipping kit to the wall, following the steps as shown.

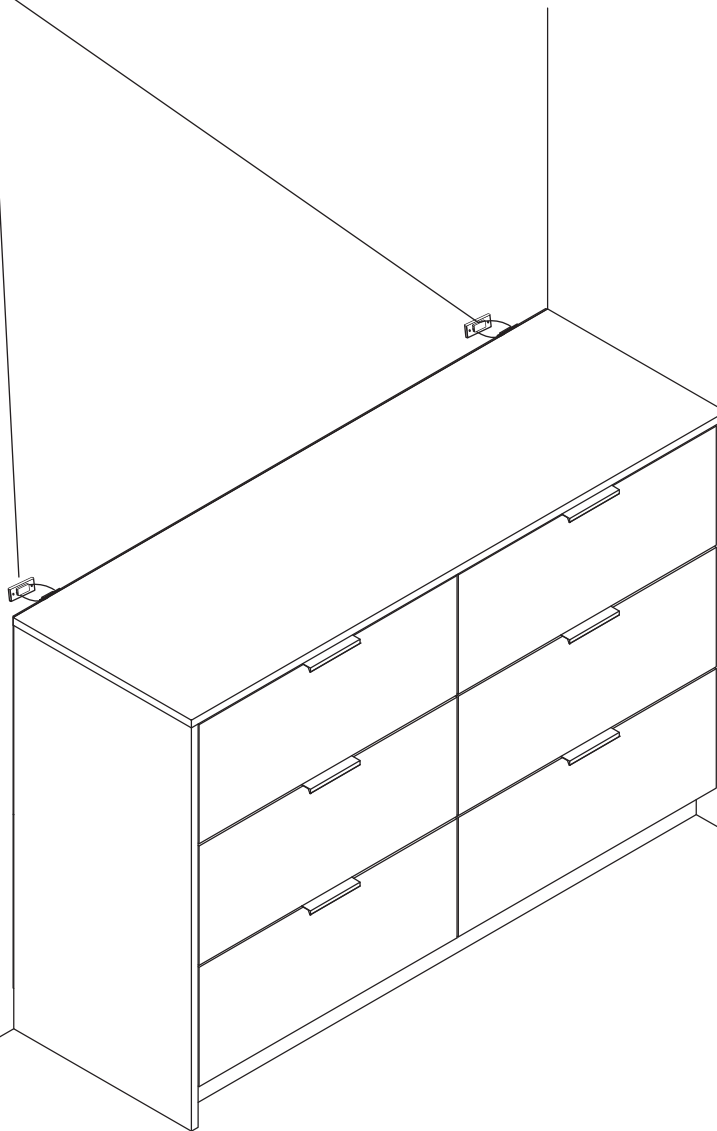
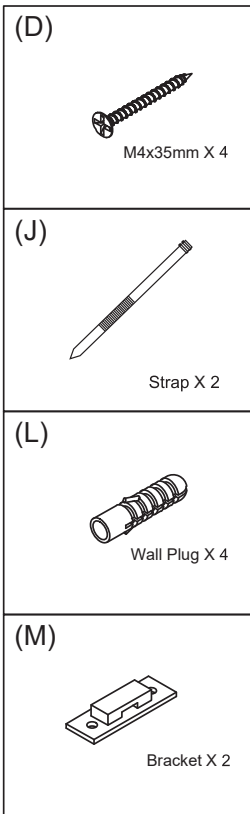
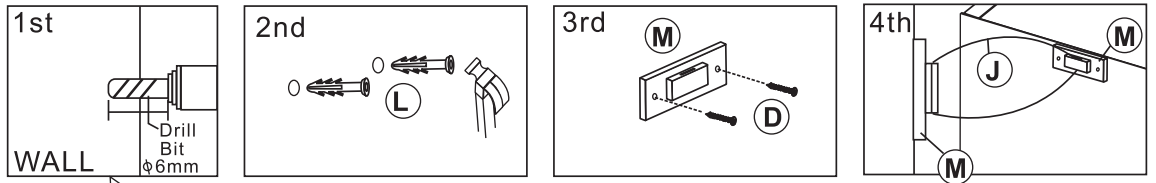

Assembly complete