

XXXXXX(MY)

# NATURAL WAX

## PANAMA 2 DOOR WARDROBE

### ASSEMBLY INSTRUCTIONS

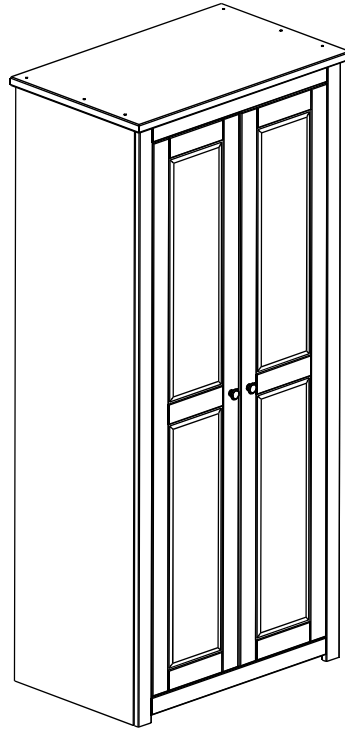

### IMPORTANT FOR DOMESTIC USE ONLY

PLEASE READ BEFORE YOU CONTINUE FURTHER

## CARE AND MAINTENANCE

After unpacking this product please keep the original packaging in case it needs to be returned for any reason.

- Please ensure all fittings and parts are present before commencing with assembly.
- Never drag or push products as this could cause damage to the joints making it inferior.
- We strongly recommend that you keep children away from your work area.
- We recommend that you lay a blanket or sheet on the floor to avoid damage to both your floor and the product.
- Assemble this product as close to its final position as possible.
- Do not place this product next to a radiator or in direct sunlight.
- Do not drag or push items across your high gloss furniture as this may cause the surface to scratch
- Wood is a natural product and may expand if subjected to damp and may shrink or crack if subjected to heat. Therefore it is recommended that room temperature is maintained, with no sudden temperature fluctuations.
- Make sure any spillage is wiped off immediately.
- Do not place hot or chilled items directly on to the surface, use a place mat or marking will occur.
- For general cleaning use a soft cotton or micro fibre cloth, and do not use detergents of any kind.
- From time to time it may be necessary to tighten fittings, regular inspections should be carried out.
- Do not place on a wet or damp floor as staining may occur to your floor.

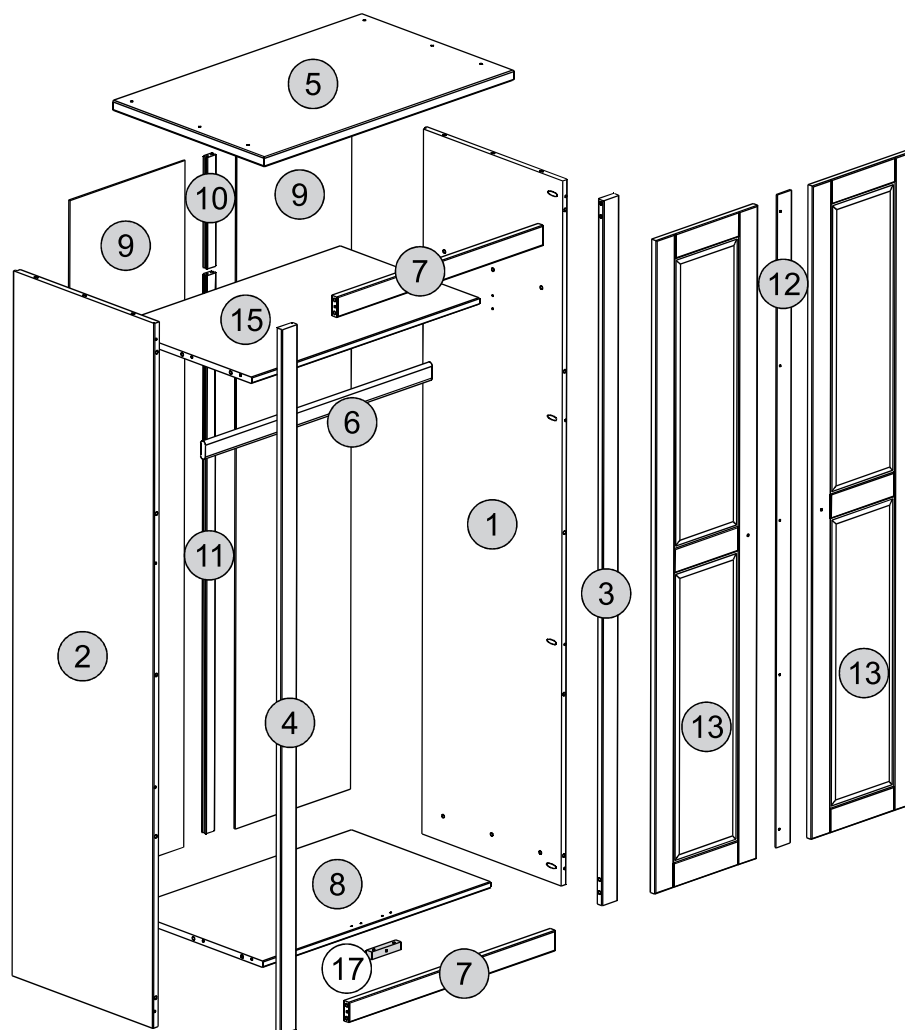



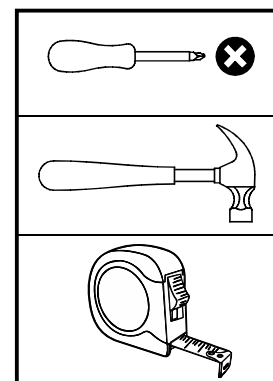





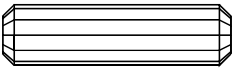
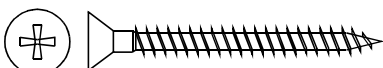

## TOOLS REQUIRED

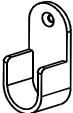
**PARTS LIST****Please Note:**

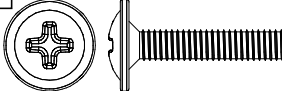
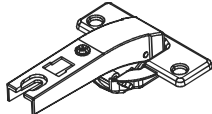
The highlighted parts below have been stamped with the part number to help identify them during assembly

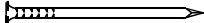
<b>Part Number</b>	<b>Part Code</b>	<b>Part Description</b>	<b>Quantity</b>	<b>Carton</b>
1	S100-101-039-MY1-01	Right Side Panel	1	1/2
2	S100-101-039-MY1-02	Left Side Panel	1	1/2
3	S100-101-039-MY1-03	Right Front Upright	1	1/2
4	S100-101-039-MY1-04	Left Front Upright	1	1/2
5	S100-101-039-MY1-05	Top Panel	1	2/2
6	S100-101-039-MY1-06	Hanger	1	2/2
7	S100-101-039-MY1-07	Front Crossbeam	2	1/2
8	S100-101-039-MY1-08	Base	1	2/2
9	S100-101-039-MY1-09	Back Panel	2	1/2
10	S100-101-039-MY1-10	Back Strip (Upper)	1	1/2
11	S100-101-039-MY1-11	Back Strip (Lower)	1	1/2
12	S100-101-039-MY1-12	Door Strip	1	1/2
13	S100-101-039-MY1-13	Door	2	1/2
15	S100-101-039-MY1-15	Fixed Shelf	1	2/2
17	S100-101-039-MY1-17	Support Block	1	2/2

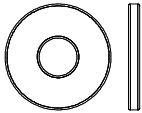
## FITTINGS LIST

<p><b>A</b></p>  <p>+1/2 Dowel Ø8,0 x 30mm (36x)</p>	<p><b>B</b></p>  <p>+1/1 Flat Head Screw Ø4,0 x 40mm (6x)</p>	<p><b>C</b></p>  <p>+1/2 Pan Head Screw Ø3,5 x 30mm (28x)</p>	<p><b>D</b></p>  <p>+1/2 Flat Head Screw Ø3,5 x 14mm (49X)</p>
<p><b>E</b></p>  <p>Hanger Support (2x)</p>	<p><b>F</b></p>  <p>Handle (2x)</p>	<p><b>G</b></p>  <p>Flan Head Screw M4 x 22mm (2x)</p>	<p><b>H</b></p>  <p>Hinge (Right) (6x)</p>
<p><b>I</b></p>  <p>Hinge (Left) (6x)</p>	<p><b>J</b></p>  <p>+1/2 Nail 10x10 (38x)</p>	<p><b>K</b></p>  <p>Anti - Tip - Kit (1x)</p>	<p><b>L</b></p>  <p>Washer (2x)</p>
<p><b>M</b></p>  <p>Door Catch (4x)</p>	<p><b>N</b></p>  <p>Door Roller (4x)</p>		

# STEP 1

## PARTS REQUIRED

1 - RIGHT SIDE PANEL x1

2 - LEFT SIDE PANEL x1

## HARDWARE REQUIRED

A  16  
Ø8.0 x 30mm

D  04  
Ø3.5 x 14mm

E  02

## TOOLS REQUIRED

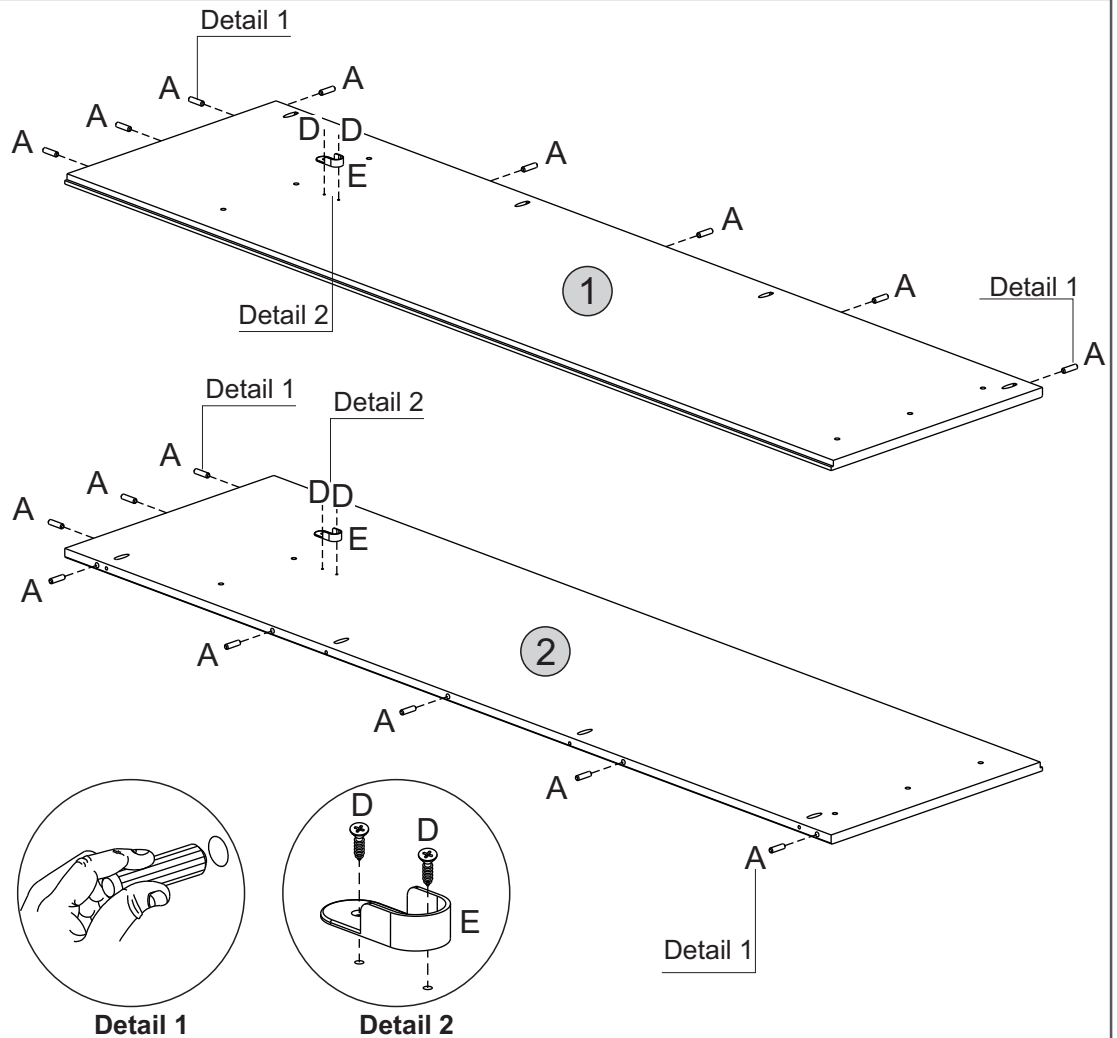
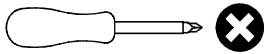
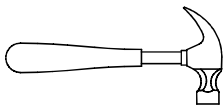

# STEP 2

## PARTS REQUIRED

15 - FIXED SHELF x1

## HARDWARE REQUIRED

A  06  
Ø8.0 x 30mm

D  04  
Ø3.5 x 14mm

N  02

## TOOLS REQUIRED

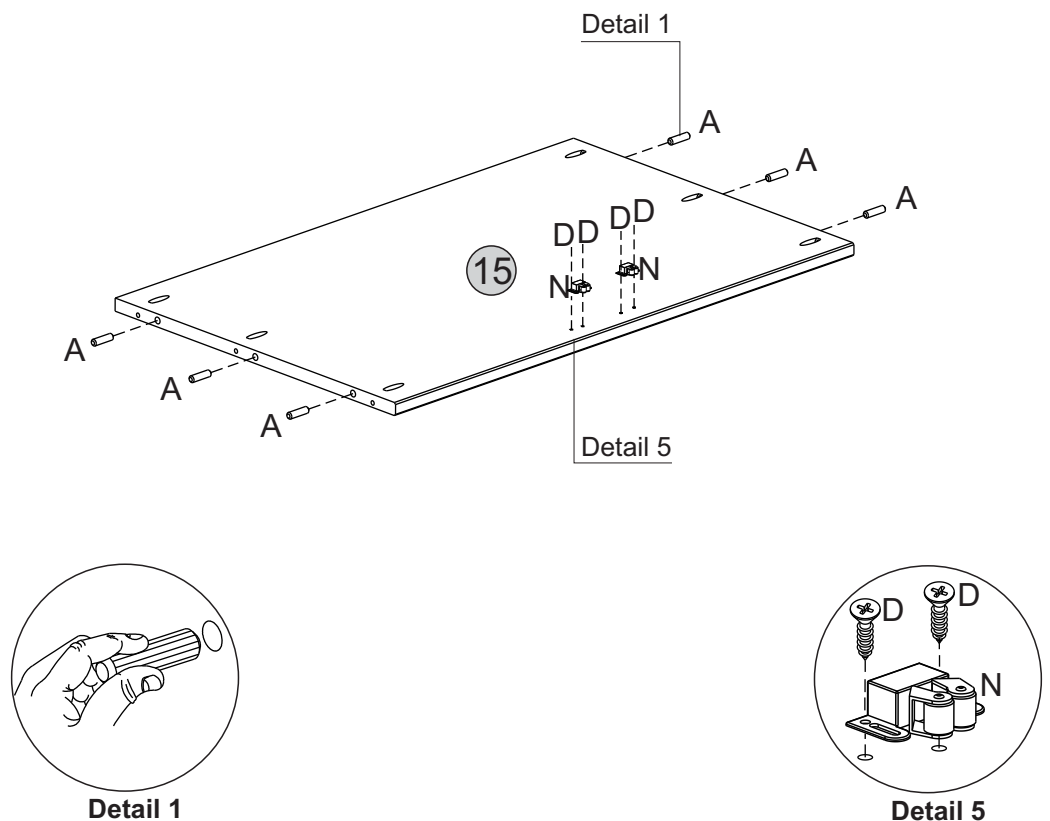
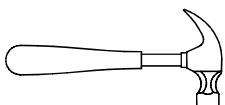

# STEP 3

## PARTS REQUIRED

8 - BASE x1

17 - SUPPORT BLOCK x1

## HARDWARE REQUIRED

A  Ø8,0 x 30mm 06

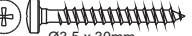
C  Ø3,5 x 30mm 02

D  Ø3,5 x 14mm 04

N  02

## TOOLS REQUIRED

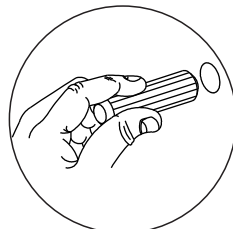
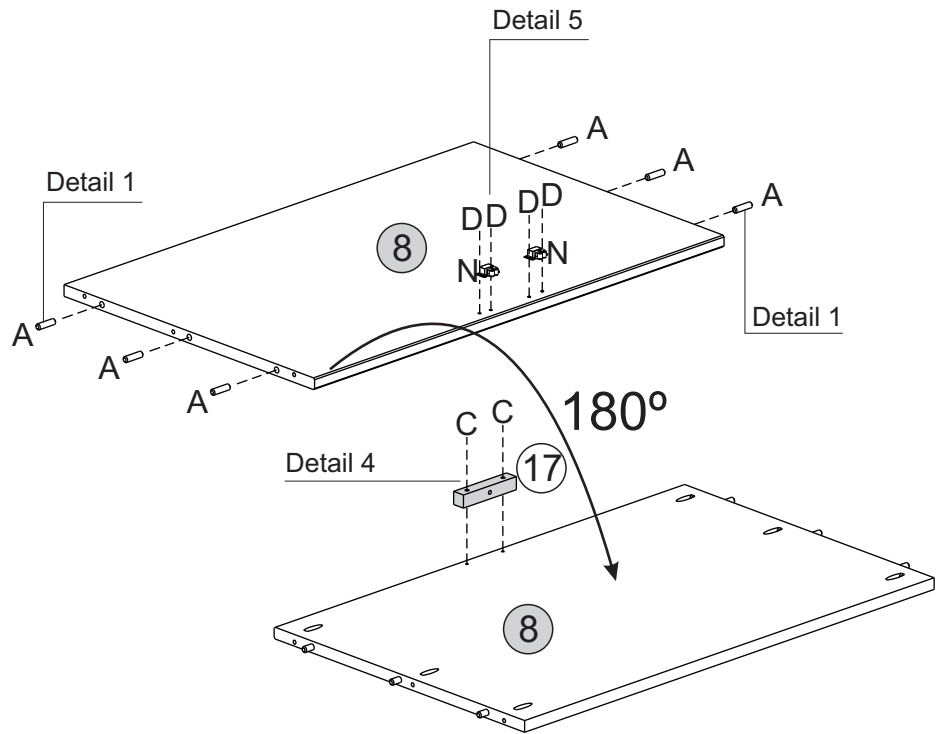
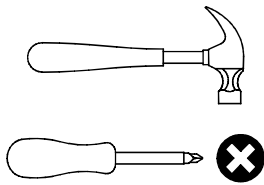

Detail 1

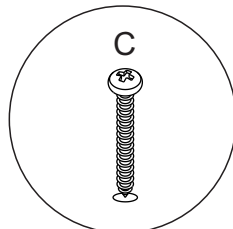

Detail 4

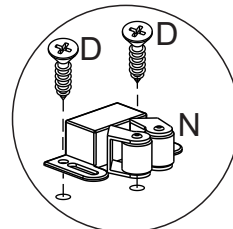

Detail 5

# STEP 4

## PARTS REQUIRED

2 - LEFT SIDE PANEL x1

15 - FIXED SHELF x1

## HARDWARE REQUIRED

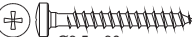
C  Ø3,5 x 30mm 03

## TOOLS REQUIRED

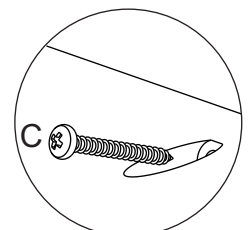
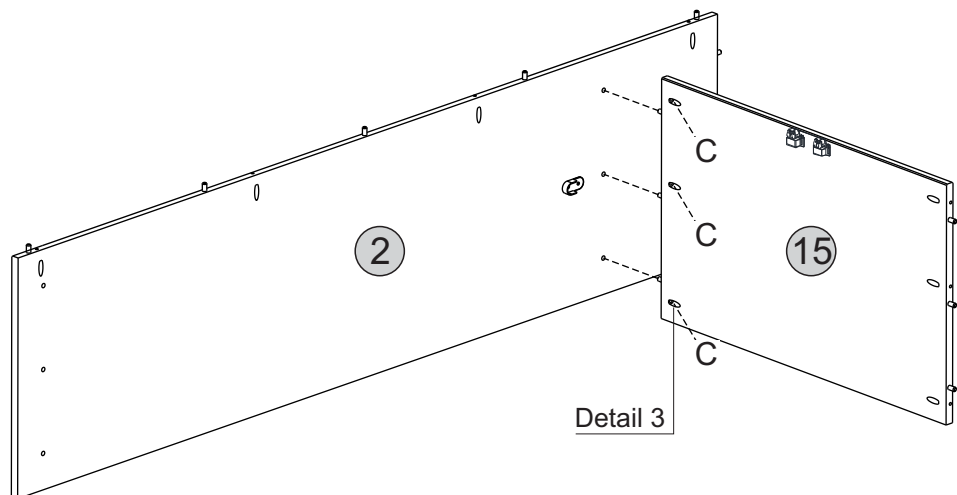
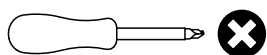

Detail 3

# STEP 5

## PARTS REQUIRED

8 - BASE x1

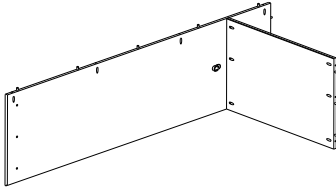

## HARDWARE REQUIRED

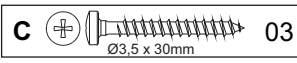

## TOOLS REQUIRED

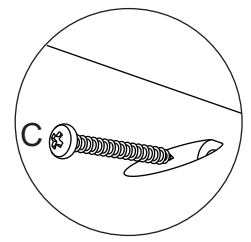
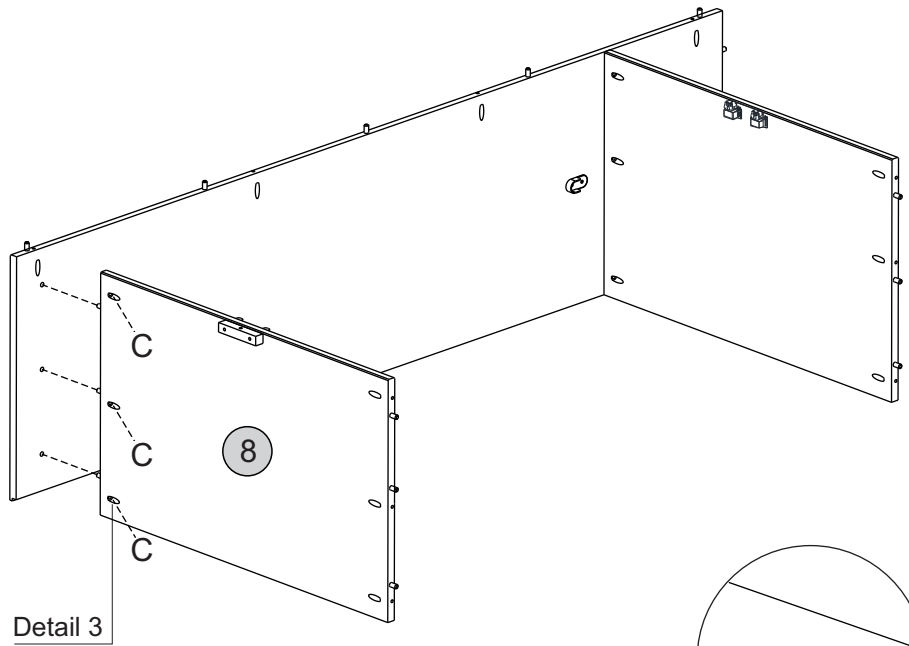
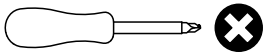

Detail 3

# STEP 6

## PARTS REQUIRED

1 - RIGHT SIDE PANEL x1

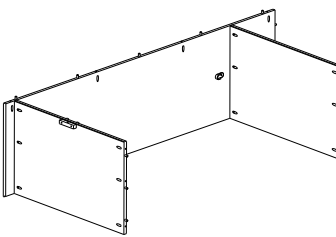

## HARDWARE REQUIRED

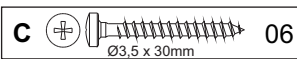

## TOOLS REQUIRED

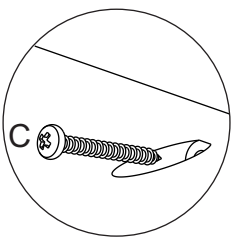
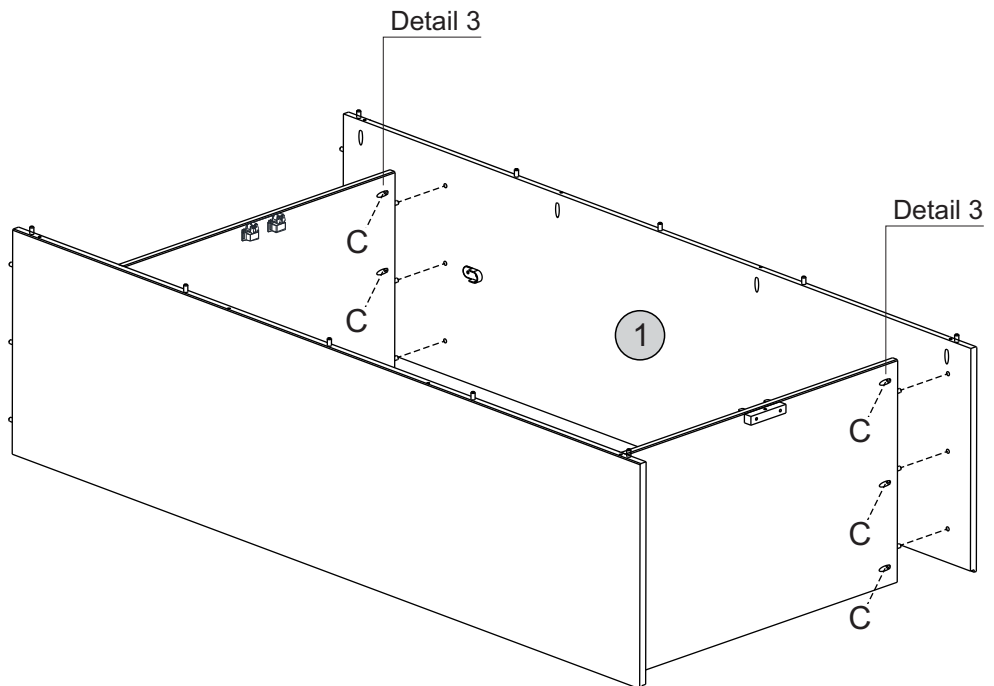
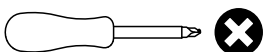

Detail 3

# STEP 7

## PARTS REQUIRED

3 - RIGHT FRONT UPRIGHT x1

4 - LEFT FRONT UPRIGHT x1

7 - FRONT CROSSBEAM x2

## HARDWARE REQUIRED

A  Ø8,0 x 30mm 08

D  Ø3,5 x 14mm 12

I  Hinge (Left) 06

## TOOLS REQUIRED

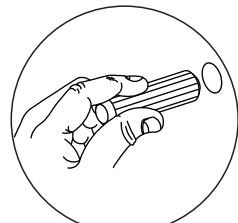
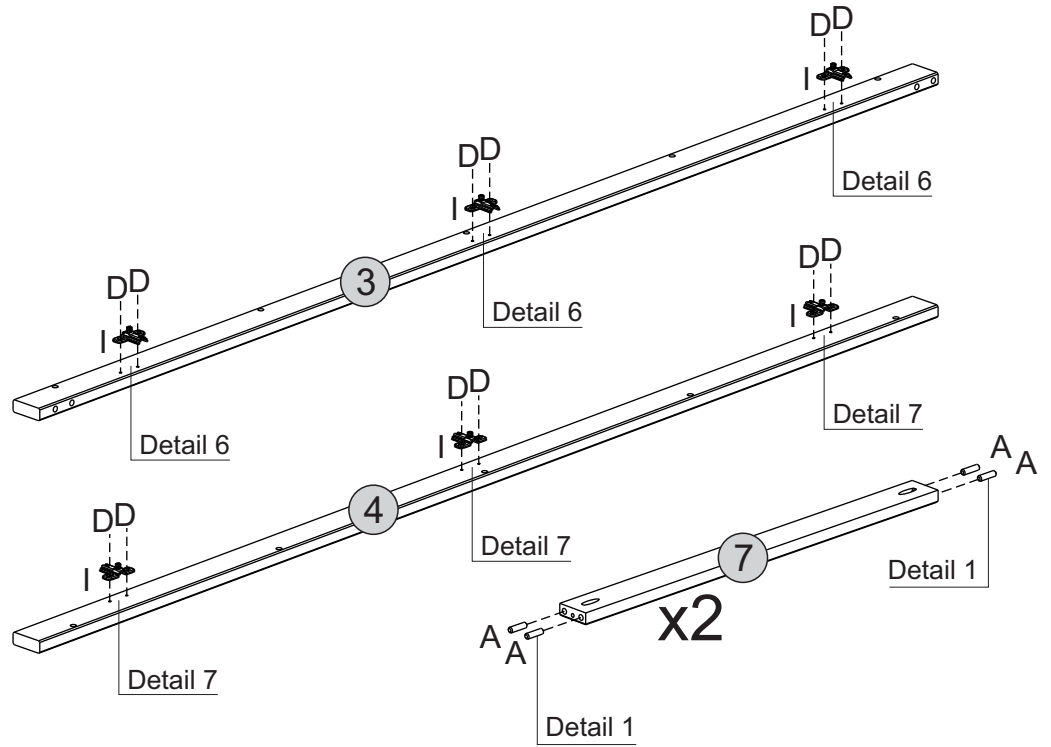
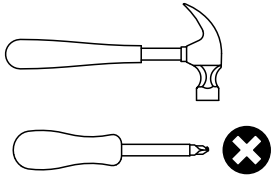

Detail 1

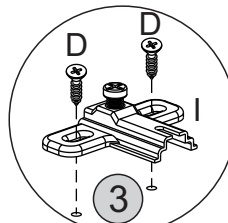

Detail 6

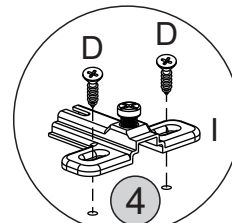

Detail 7

# STEP 8

## PARTS REQUIRED

3 - RIGHT FRONT UPRIGHT x1

4 - LEFT FRONT UPRIGHT x1

7 - FRONT CROSSBEAM x2

## HARDWARE REQUIRED

C  Ø3,5 x 30mm 04

## TOOLS REQUIRED

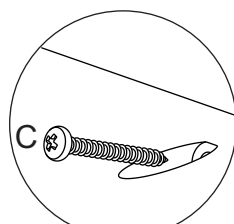
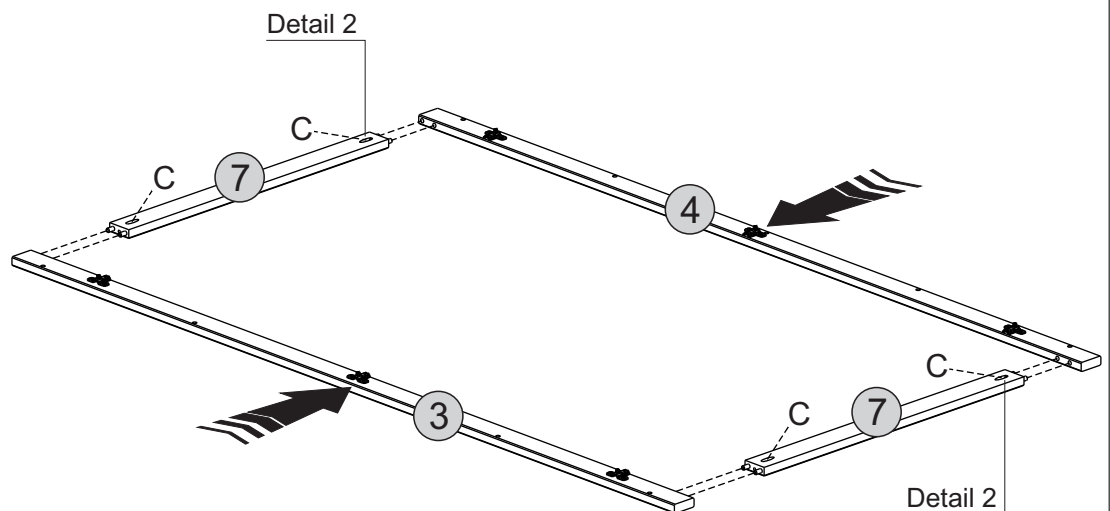
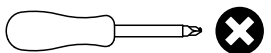

Detail 2

# STEP 9

**PARTS REQUIRED**

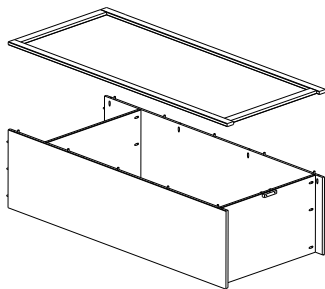

**HARDWARE REQUIRED**

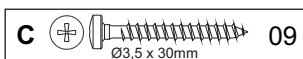

**TOOLS REQUIRED**

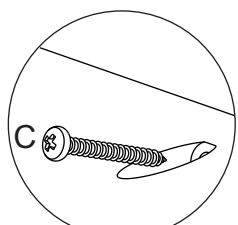
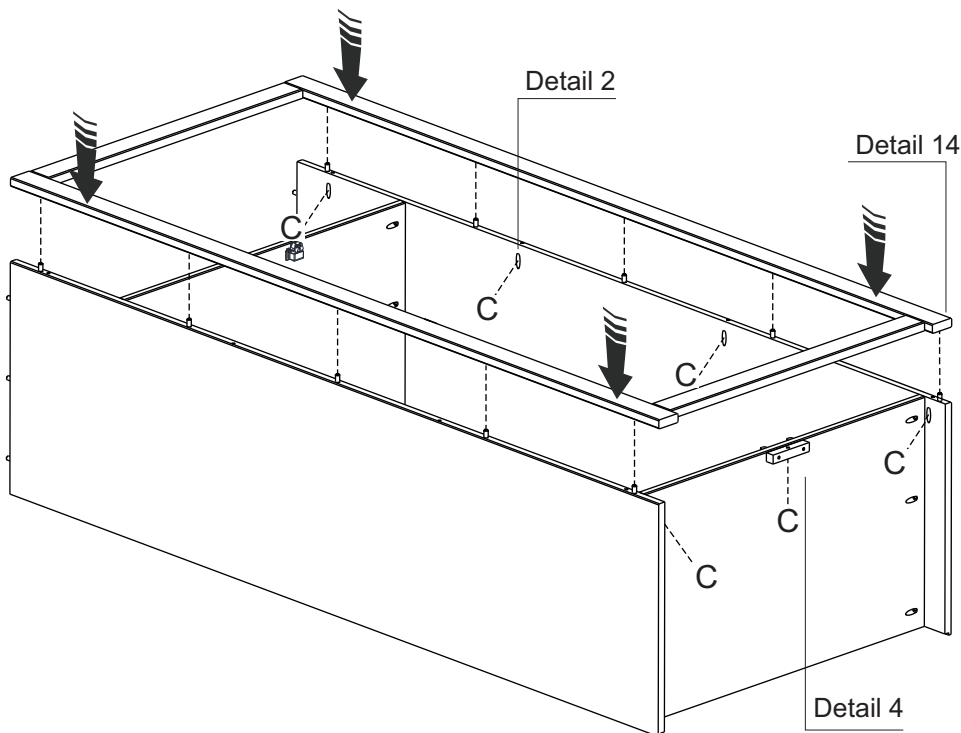
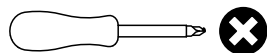

Detail 2

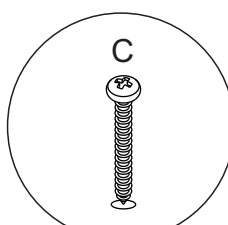

Detail 4

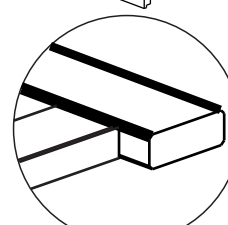

Detail 14

# STEP 10

**PARTS REQUIRED**

5 - TOP PANEL x1

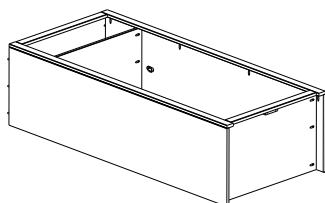

**HARDWARE REQUIRED**

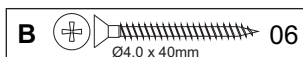

**TOOLS REQUIRED**

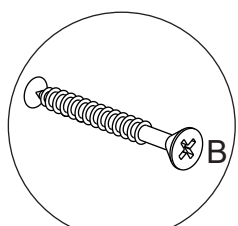
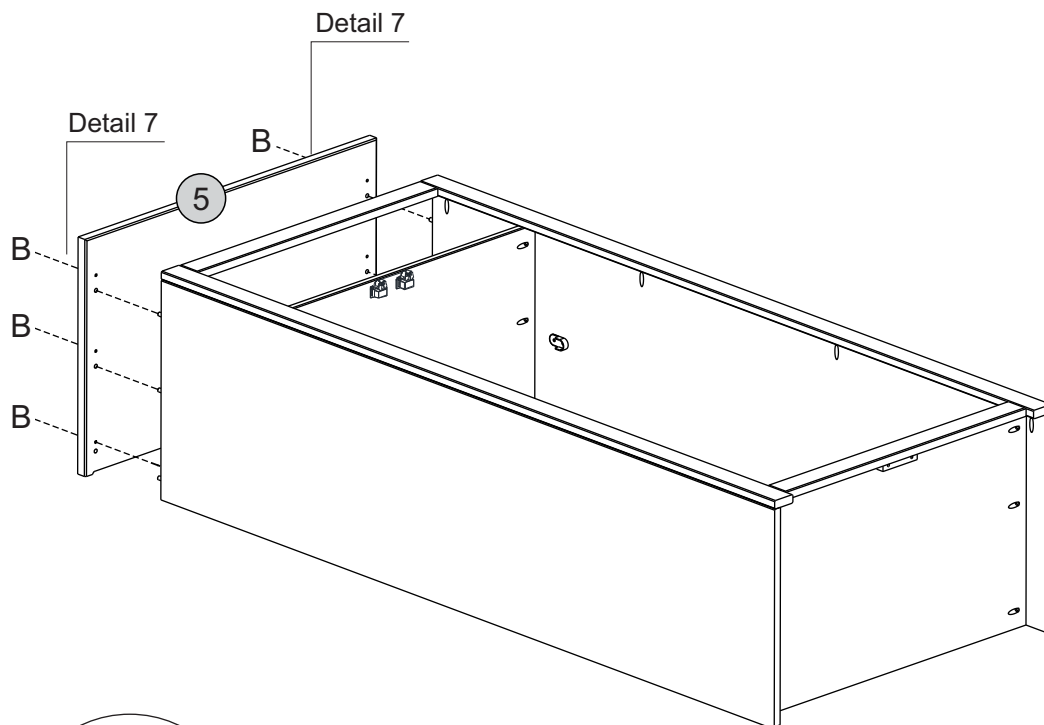
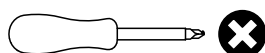

Detail 7

# STEP 11

## PARTS REQUIRED

9 - BACK PANEL x2

10 - BACK STRIP (UPPER) x1

11 - BACK STRIP (LOWER) x1

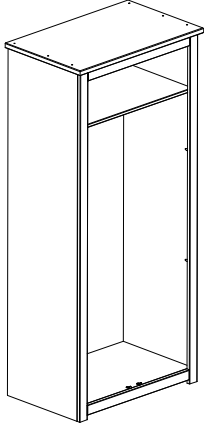

## HARDWARE REQUIRED

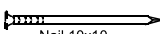
J  38  
Nail 10x10

## TOOLS REQUIRED

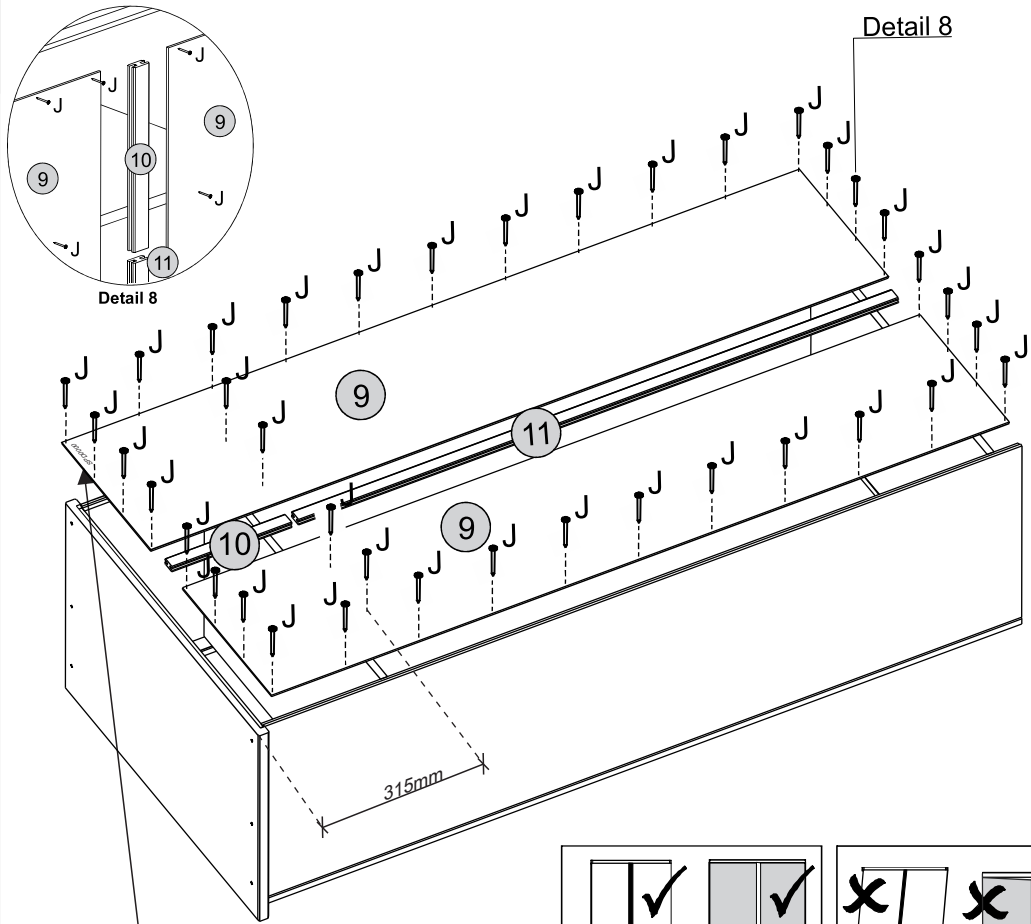
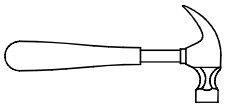

\* For your future reference  
Order Number should be here

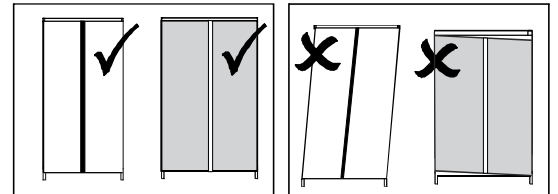

# STEP 12

## PARTS REQUIRED

12 - DOOR STRIP x1

13 - DOOR x2

## HARDWARE REQUIRED

D  17  
Ø3.5 x 14mm

H  06

## TOOLS REQUIRED

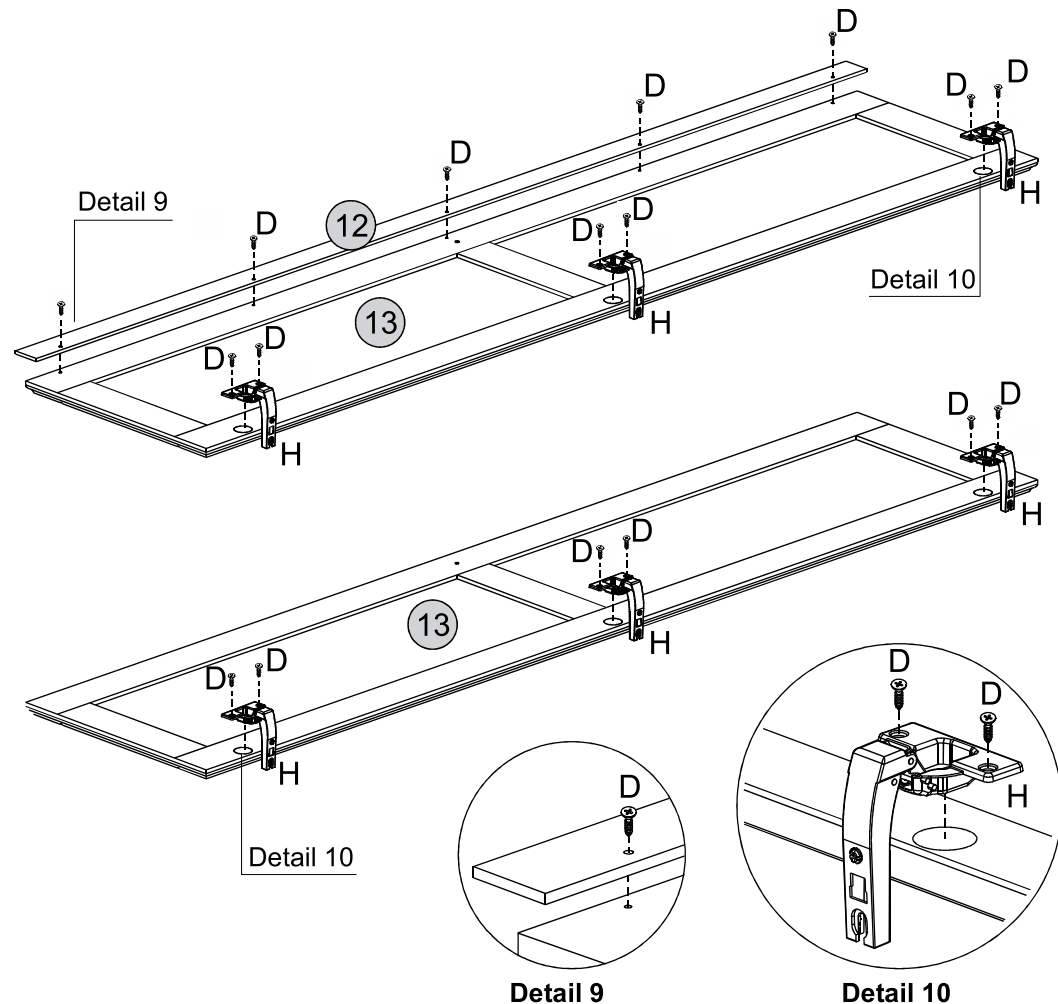
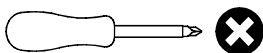

# STEP 13

## PARTS REQUIRED

6 - HANGER x1

13 - DOOR x2

## HARDWARE REQUIRED

D  08  
Ø3.5 x 14mm

F  02

G  02  
M4 x 22mm

M  04

## TOOLS REQUIRED

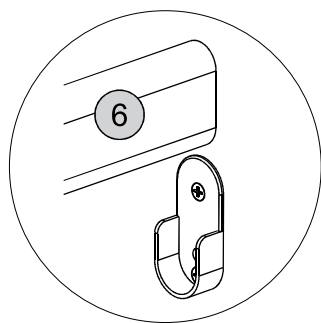
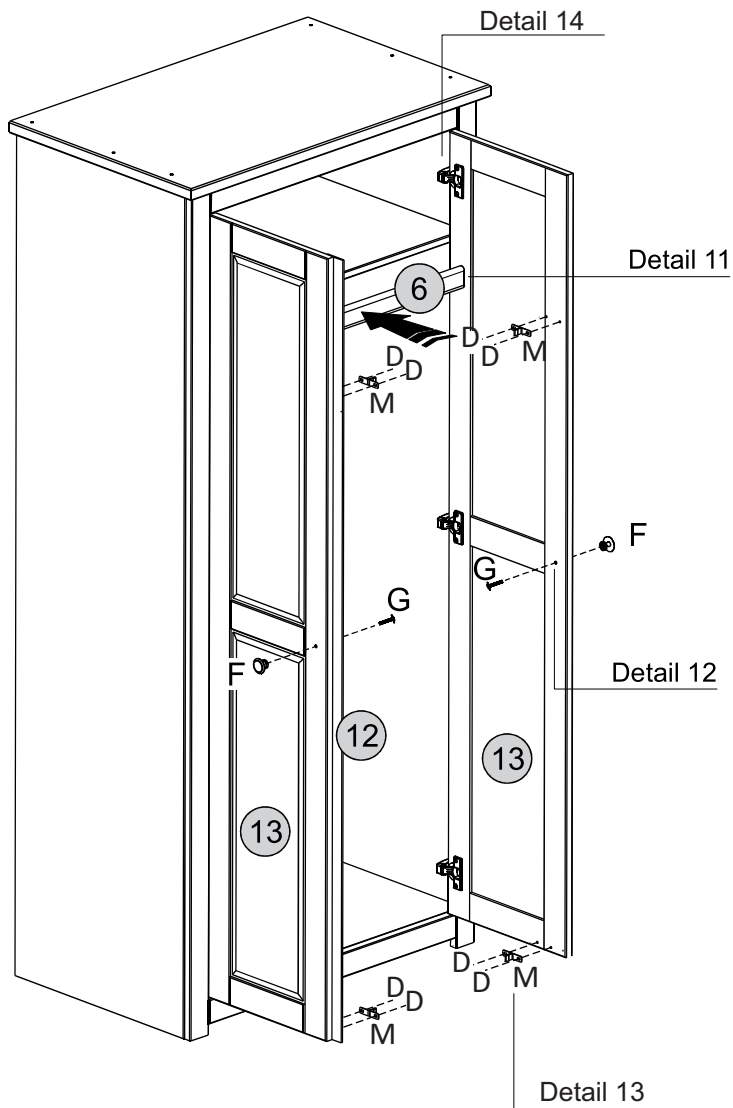
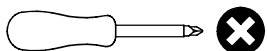

Detail 11

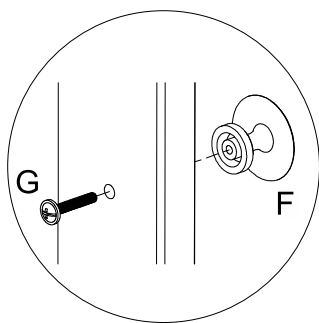

Detail 12

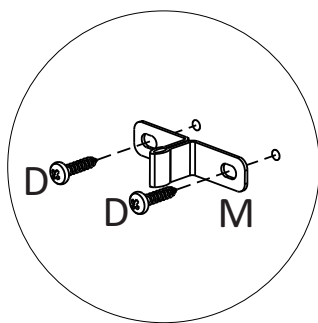

Detail 13

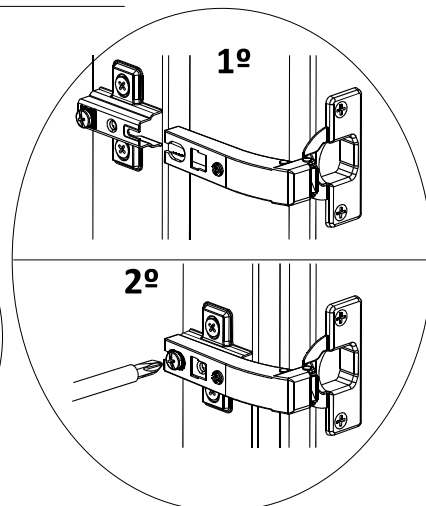

Detail 14

## ADJUSTMENTS

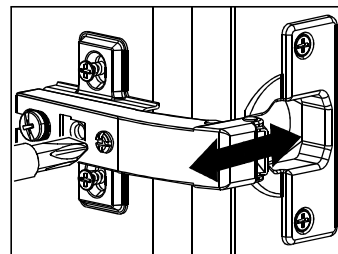
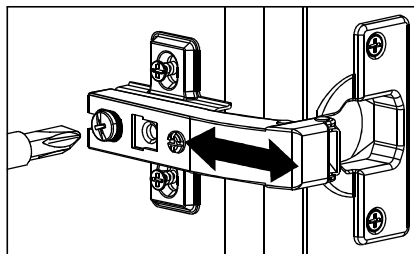
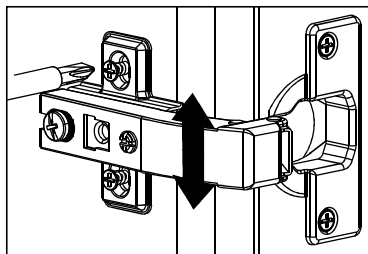





## WARNING

**Serious or fatal injuries can occur from furniture tipping over. To prevent the furniture from tipping over we recommend that it is permanently fixed to the wall.**

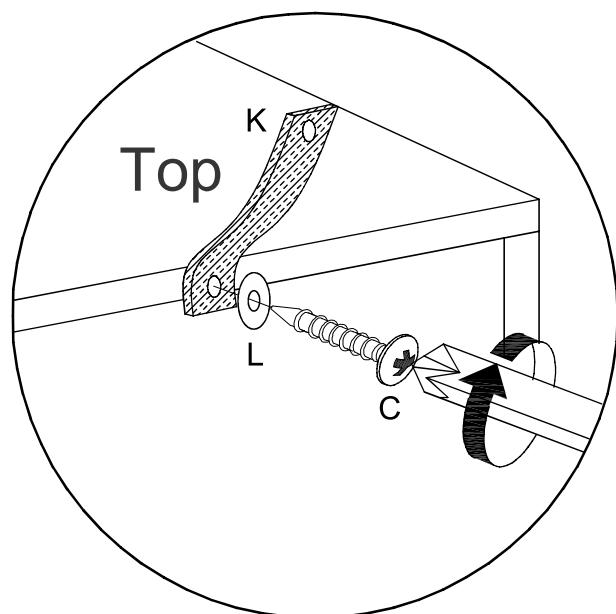
Wall fixings are not supplied with this product as different wall materials require different types of fixing devices.

Please make sure you use fixings suitable for the walls in your home.



K		1
	Strap	
L		2
	Washer	
C		1
	Ø3,5 x 30mm	

