

56633(MY)

NATURAL WAX

PANAMA 6 DRAWER CHEST

ASSEMBLY INSTRUCTIONS

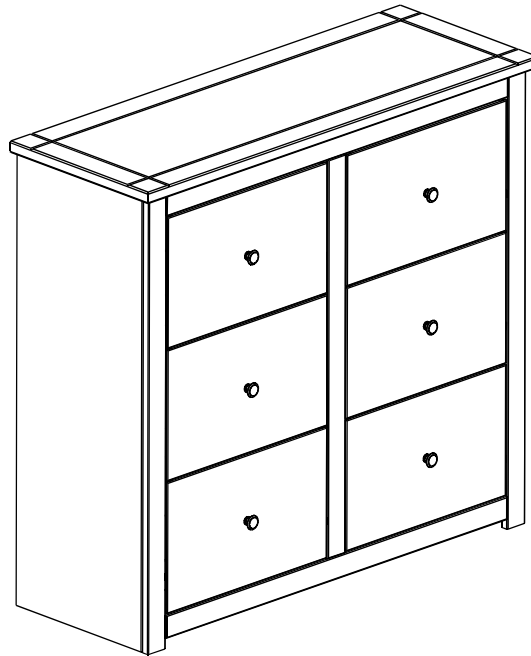

IMPORTANT FOR DOMESTIC USE ONLY

PLEASE READ BEFORE YOU CONTINUE FURTHER

CARE AND MAINTENANCE

- After unpacking this product please keep the original packaging in case it needs to be returned for any reason.
- Please ensure all fittings and parts are present before commencing with assembly.
 - Never drag or push products as this could cause damage to the joints making it inferior.
 - We strongly recommend that you keep children away from your work area.
 - We recommend that you lay a blanket or sheet on the floor to avoid damage to both your floor and the product.
 - Assemble this product as close to its final position as possible.
 - Do not place this product next to a radiator or in direct sunlight.
 - Do not drag or push items across your high gloss furniture as this may cause the surface to scratch
 - Wood is a natural product and may expand if subjected to damp and may shrink or crack if subjected to heat. Therefore it is recommended that room temperature is maintained, with no sudden temperature fluctuations.
 - Make sure any spillage is wiped off immediately.
 - Do not place hot or chilled items directly on to the surface, use a place mat or marking will occur.
 - For general cleaning use a soft cotton or micro fibre cloth, and do not use detergents of any kind.
 - From time to time it may be necessary to tighten fittings, regular inspections should be carried out.
 - Do not place on a wet or damp floor as staining may occur to your floor.

TOOLS REQUIRED

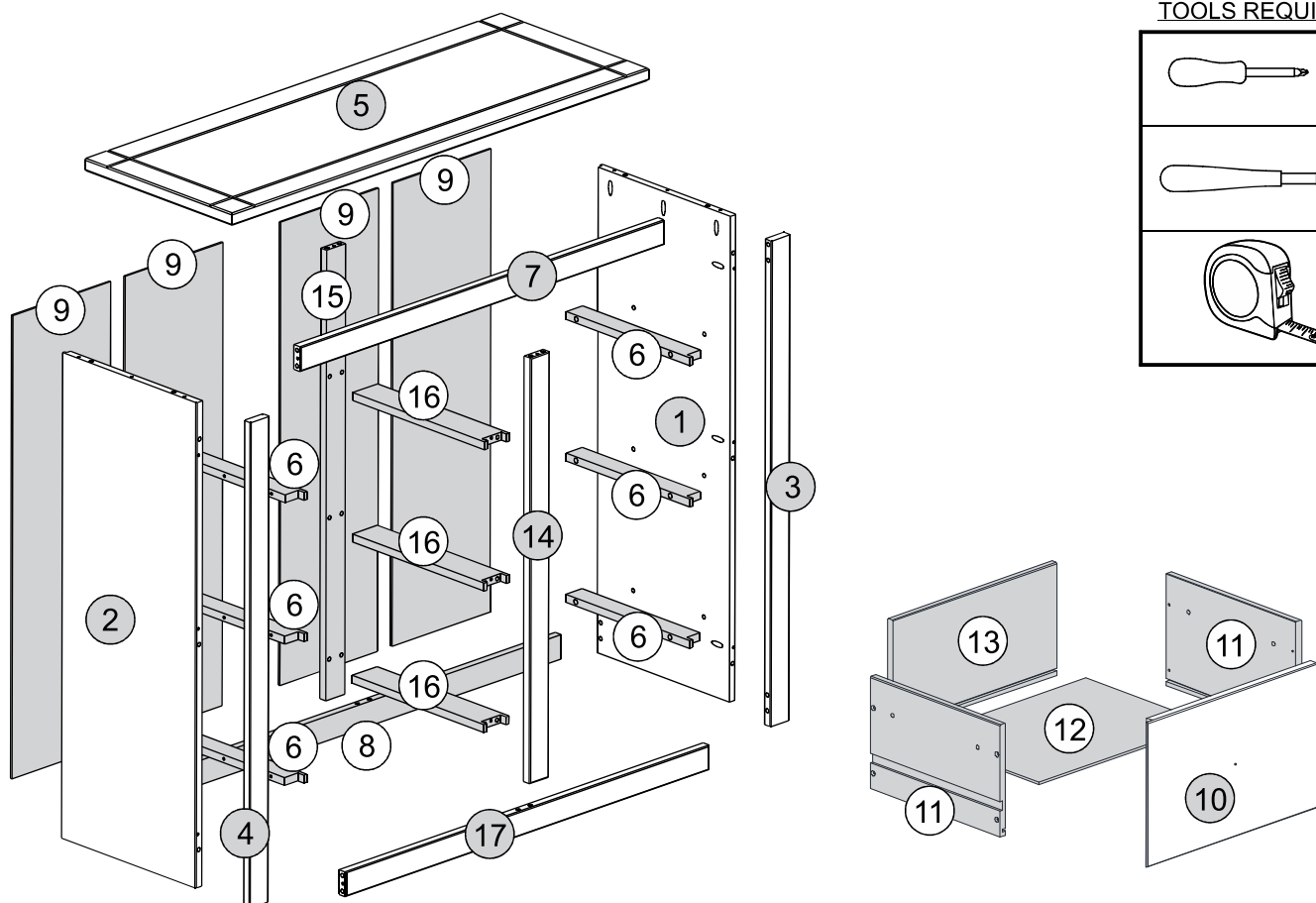
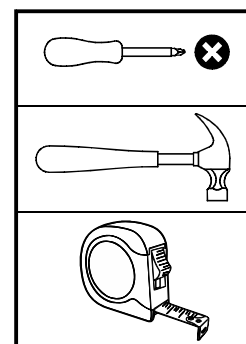







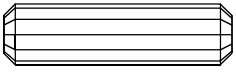

PARTS LIST

Please Note:

The highlighted parts below have been stamped with the part number to help identify them during assembly

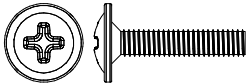
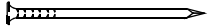
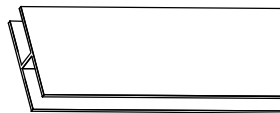
Part Number	Part Code	Part Description	Quantity	Carton
1	S100-102-045-MY1-01	Right Side Panel	1	1/1
2	S100-102-045-MY1-02	Left Side Panel	1	1/1
3	S100-102-045-MY1-03	Right Front Upright	1	1/1
4	S100-102-045-MY1-04	Left Front Upright	1	1/1
5	S100-102-045-MY1-05	Top Panel	1	1/1
6	S100-102-045-MY1-06	Drawer Runner	6	1/1
7	S100-102-045-MY1-07	Top Front Crossbeam	1	1/1
8	S100-102-045-MY1-08	Back Crossbeam	1	1/1
9	S100-102-045-MY1-09	Back Panel	4	1/1
10	S100-102-045-MY1-10	Drawer Front	6	1/1
11	S100-102-045-MY1-11	Drawer Side	12	1/1
12	S100-102-045-MY1-12	Drawer Bottom	6	1/1
13	S100-102-045-MY1-13	Drawer Back	6	1/1
14	S100-102-045-MY1-14	Centre Front Upright	1	1/1
15	S100-102-045-MY1-15	Back Upright	1	1/1
16	S100-102-045-MY1-16	Centre Drawer Runner	3	1/1
17	S100-102-045-MY1-17	Bottom Front Crossbeam	1	1/1

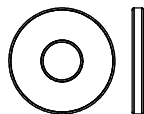
FITTINGS LIST

<p>A</p>  <p>+/2 Dowel Ø8,0 x 30mm (66x)</p>	<p>B</p>  <p>+/2 Pan Head Screw Ø3,5 x 30mm (42x)</p>	<p>C</p>  <p>+/2 Flat Head Screw Ø3,0 x 30mm (48x)</p>	<p>D</p>  <p>Handle (6x)</p>
<p>E</p>  <p>Flan Head Screw M4 x 25mm (6x)</p>	<p>F</p>  <p>+/2 Nail 10x20 (32x)</p>	<p>G</p>  <p>910mm (2x)</p>	<p>H</p>  <p>Anti - Tip - Kit (1x)</p>
<p>I</p>  <p>Washer (2x)</p>	<p>J</p>  <p>+/1 Flat Head Screw Ø3,5 x 14mm (12x)</p>		

STEP 1

PARTS REQUIRED

1 - RIGHT SIDE PANEL x1

2 - LEFT SIDE PANEL x1

HARDWARE REQUIRED

A  10
Ø8,0 x 30mm

TOOLS REQUIRED

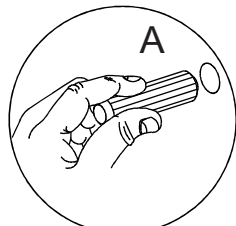
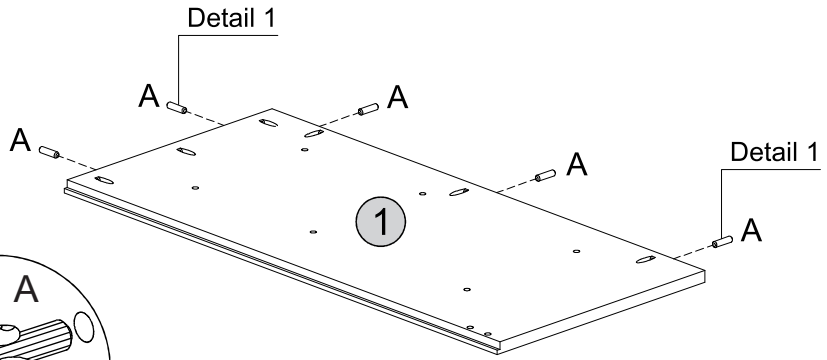
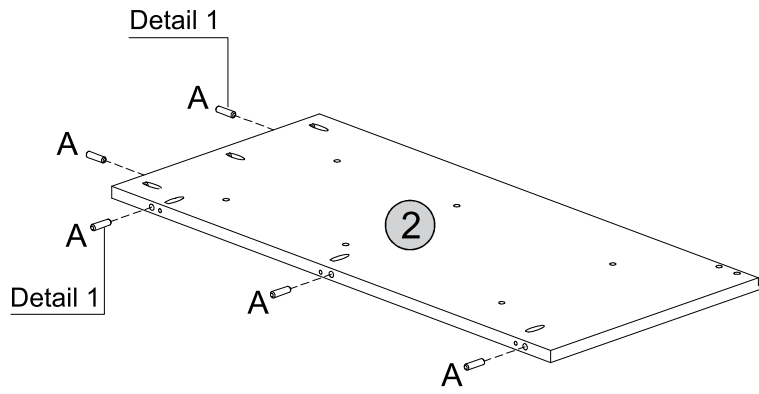
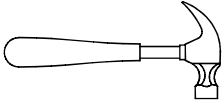

Detail 1

STEP 2

PARTS REQUIRED

1 - RIGHT SIDE PANEL x1

2 - LEFT SIDE PANEL x1

3 - RIGHT FRONT UPRIGHT x1

4 - LEFT FRONT UPRIGHT x1

HARDWARE REQUIRED

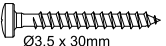
B  06
Ø3,5 x 30mm

TOOLS REQUIRED

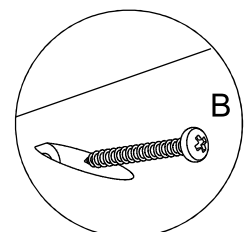
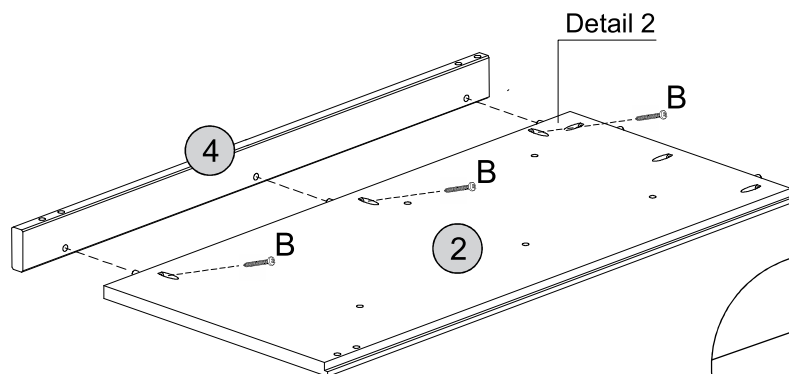
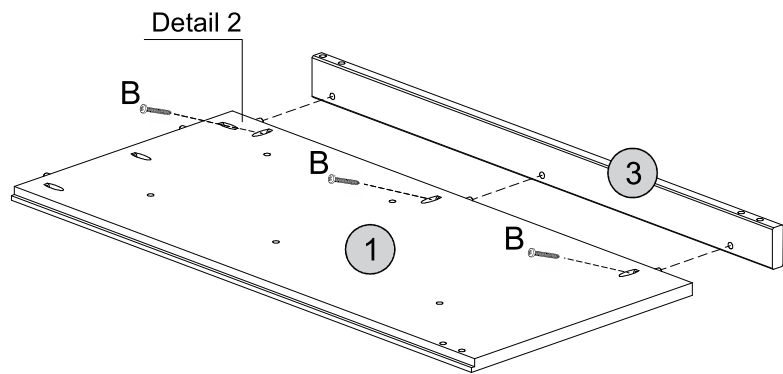
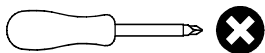

Detail 2

STEP 3

PARTS REQUIRED

7 - TOP FRONT CROSBEAM x1

8 - BACK CROSSBEAM x1

14 - CENTRE FRONT UPRIGHT x1

15 - BACK UPRIGHT x1

17 - BOTTOM FRONT CROSBEAM x1

HARDWARE REQUIRED

A  20
Ø8,0 x 30mm

TOOLS REQUIRED

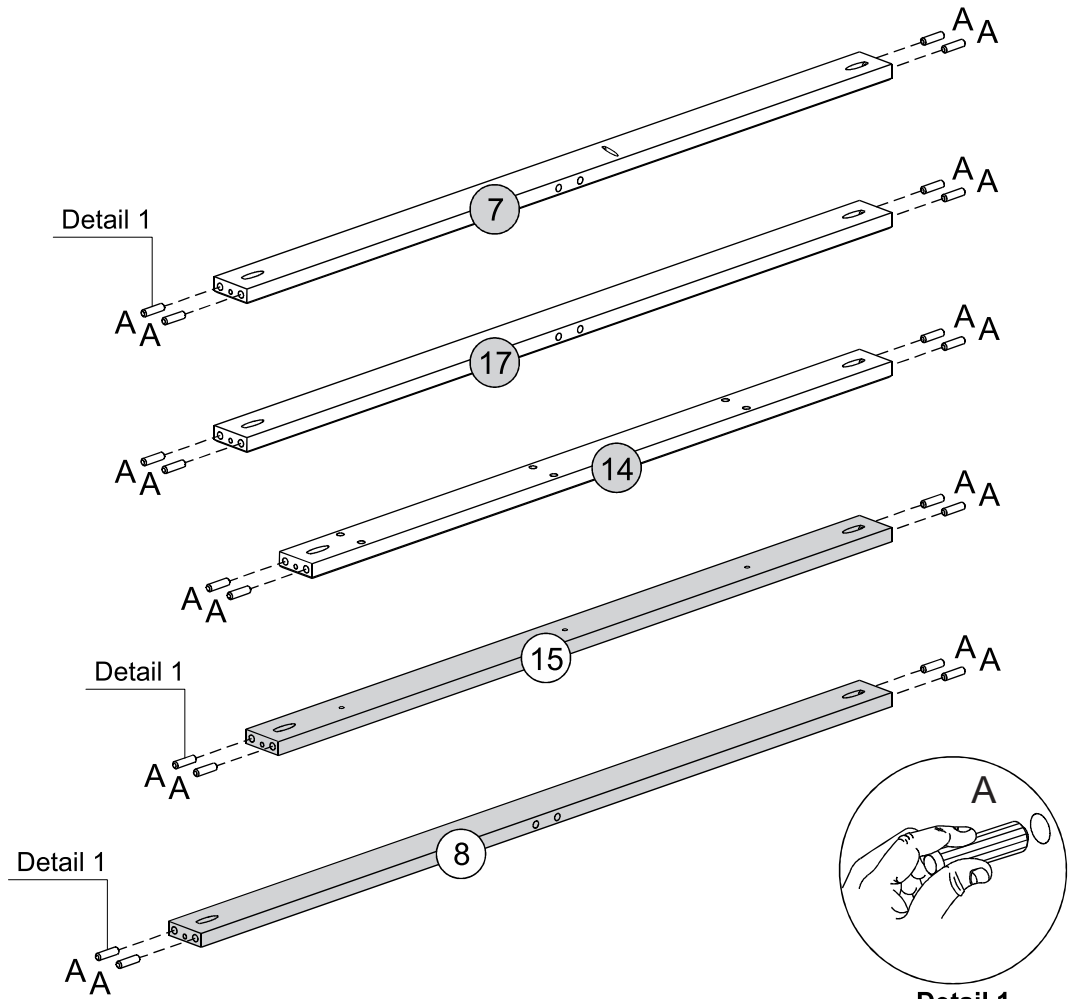
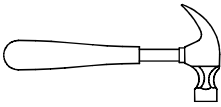

STEP 4

PARTS REQUIRED

7 - TOP FRONT CROSBEAM x1

14 - CENTRE FRONT UPRIGHT x1

17 - BOTTOM FRONT CROSBEAM x1

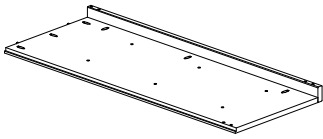

HARDWARE REQUIRED

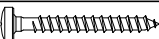
B  04
Ø3,5 x 30mm

TOOLS REQUIRED

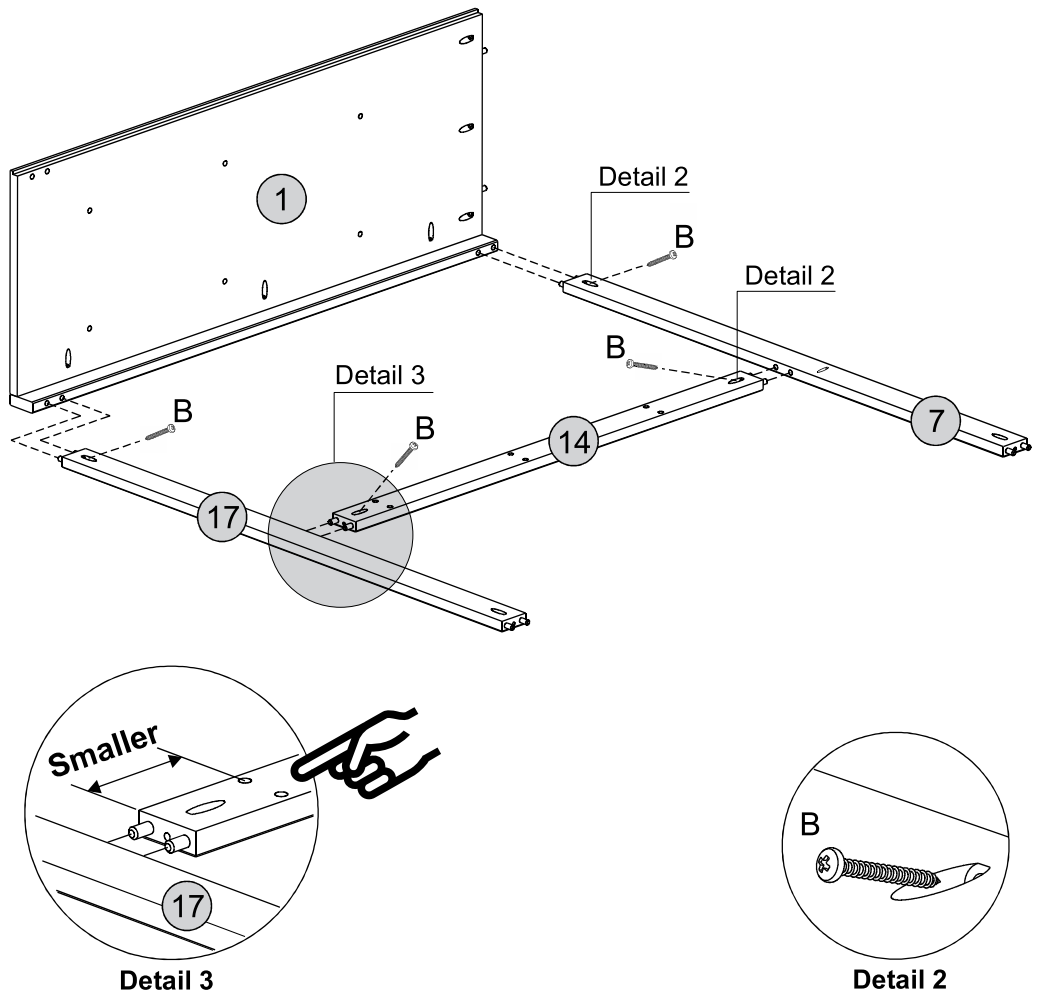
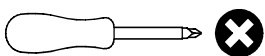

STEP 5

PARTS REQUIRED

2 - LEFT SIDE PANEL x1

8 - BACK CROSSBEAM x1

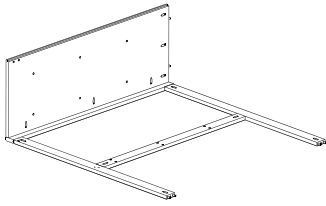

HARDWARE REQUIRED

B  04
Ø3.5 x 30mm

TOOLS REQUIRED

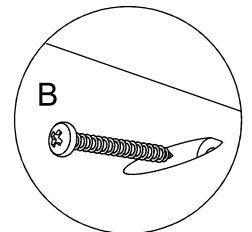
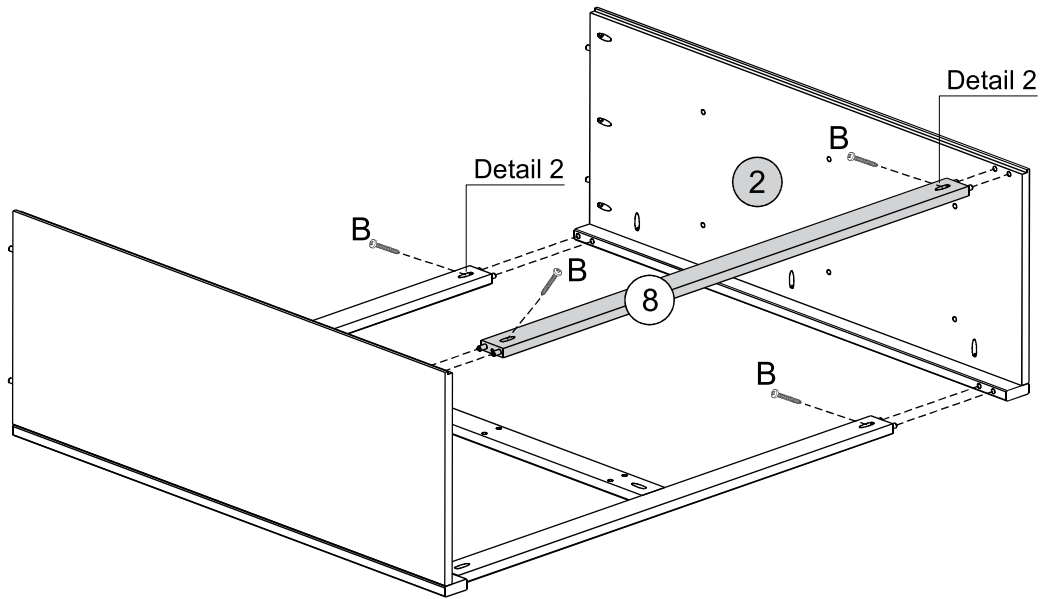
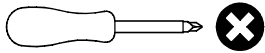

Detail 2

STEP 6

PARTS REQUIRED

16 - CENTRE DRAWER RUNNER x3

HARDWARE REQUIRED

A  12
Ø8.0 x 30mm

TOOLS REQUIRED

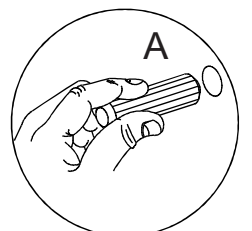
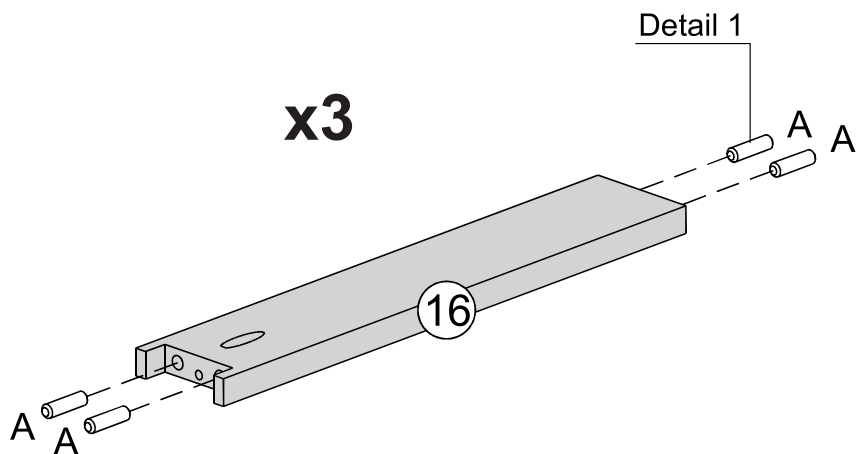
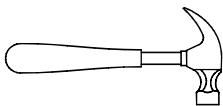

Detail 1

STEP 7

PARTS REQUIRED

15 - BACK UPRIGHT x1

16 - CENTRE DRAWER RUNNER x3

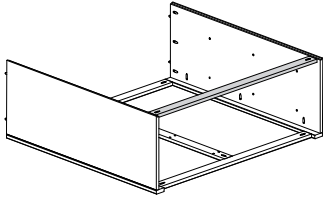

HARDWARE REQUIRED

B  Ø3.5 x 30mm 07

TOOLS REQUIRED

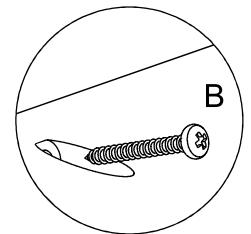
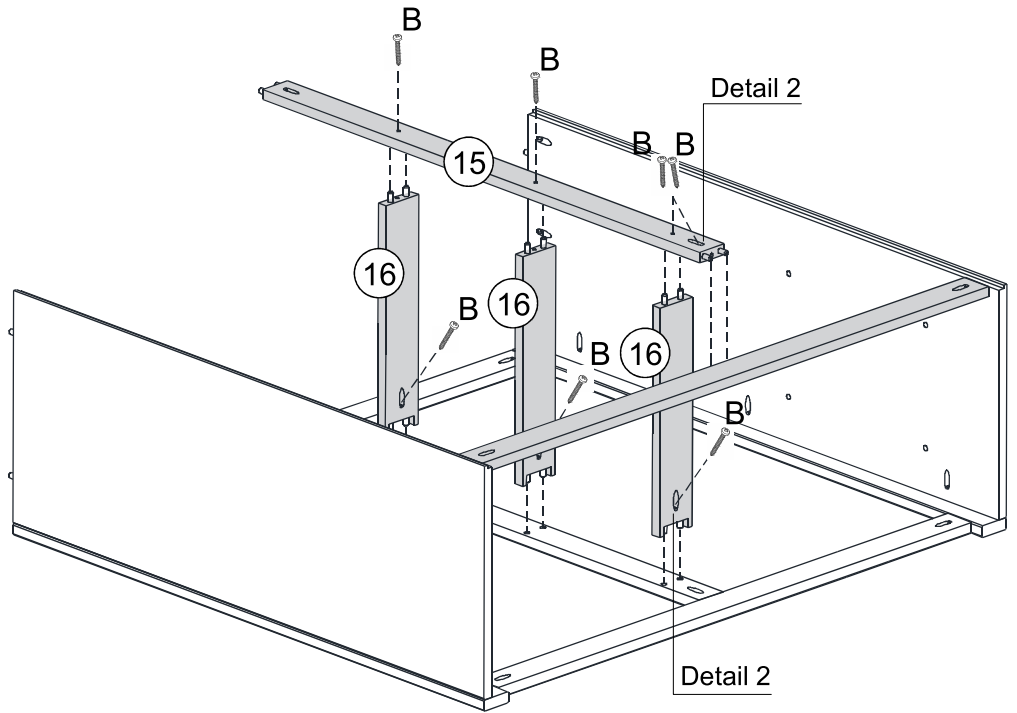
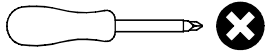

Detail 2

STEP 8

PARTS REQUIRED

5 - TOP PANEL x1

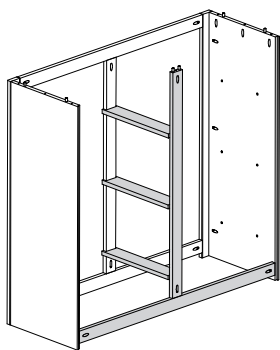

HARDWARE REQUIRED

B  Ø3.5 x 30mm 08

TOOLS REQUIRED

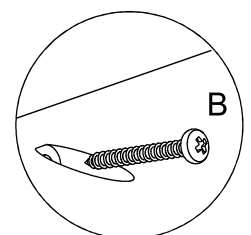
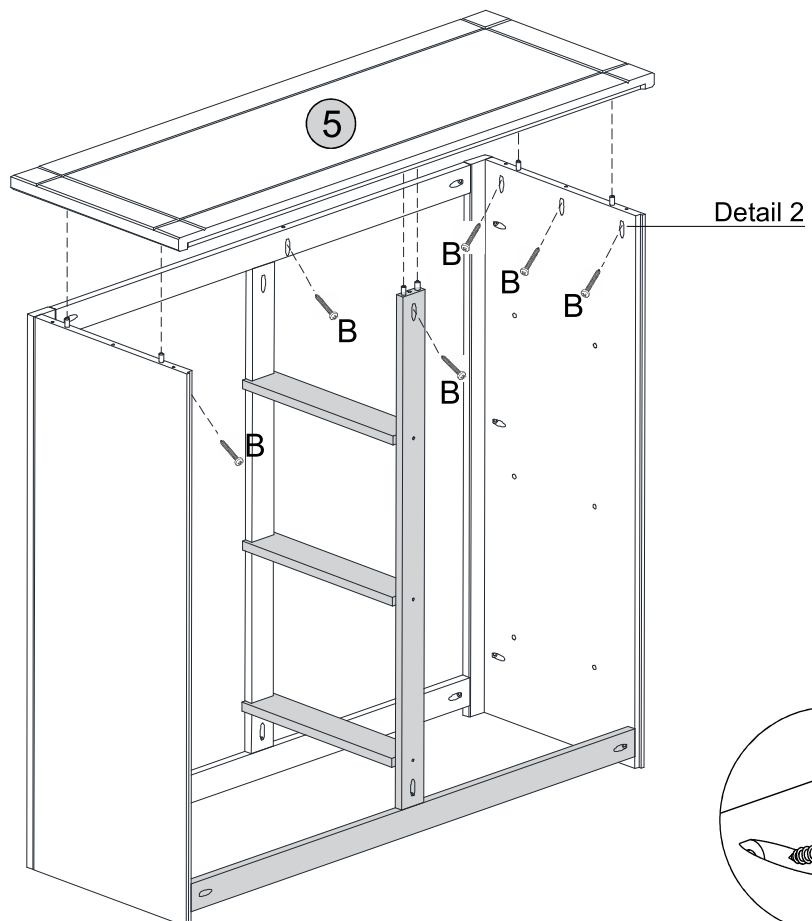
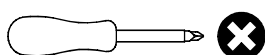

Detail 2

STEP 9

PARTS REQUIRED

6 - DRAWER RUNNER x6

HARDWARE REQUIRED

A  12
Ø8,0 x 30mm

TOOLS REQUIRED

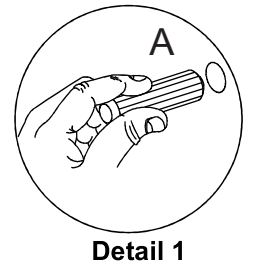
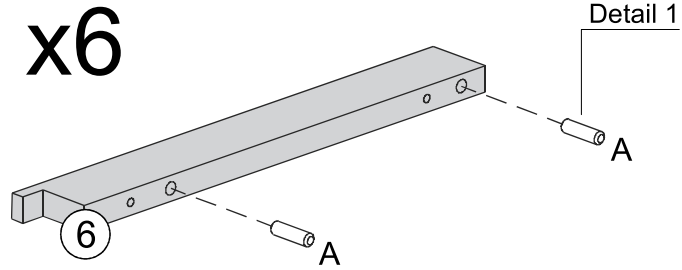
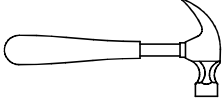

STEP 10

PARTS REQUIRED

6 - DRAWER RUNNER x6

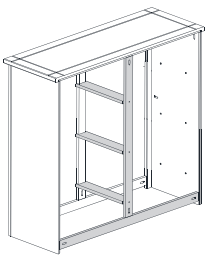

HARDWARE REQUIRED

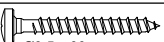
B  12
Ø3,5 x 30mm

TOOLS REQUIRED

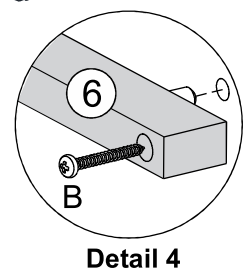
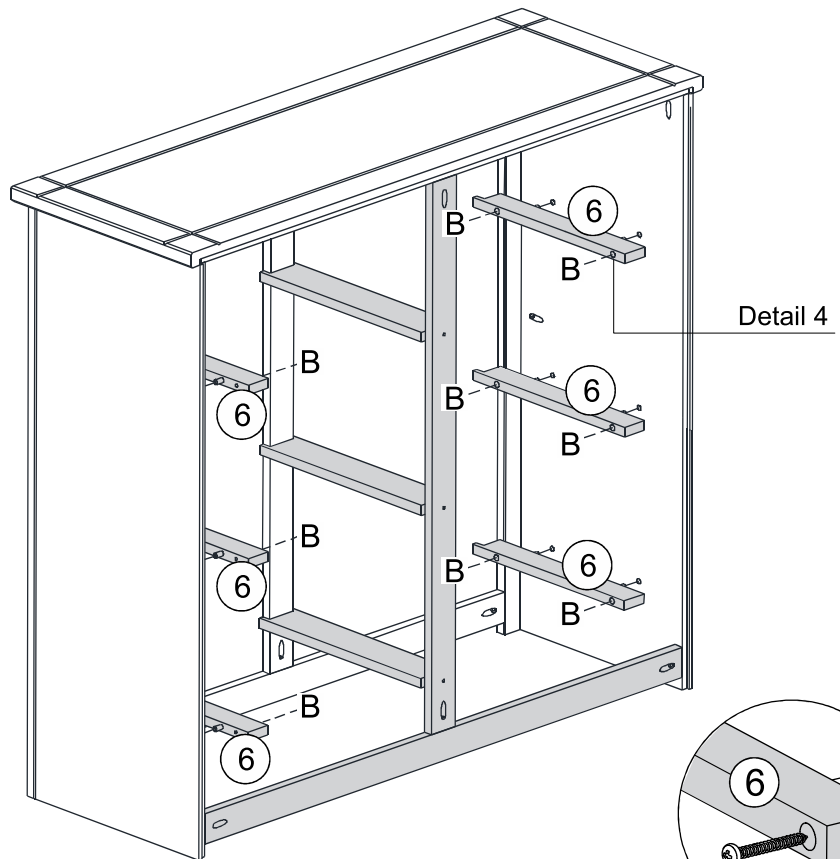
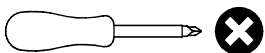

STEP 11

PARTS REQUIRED

9 - BACK PANEL x4

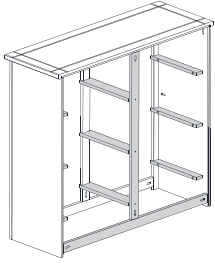

HARDWARE REQUIRED

F  Nail 10x10 32

G  02

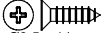
J  Ø3,5 x 14mm 12

TOOLS REQUIRED

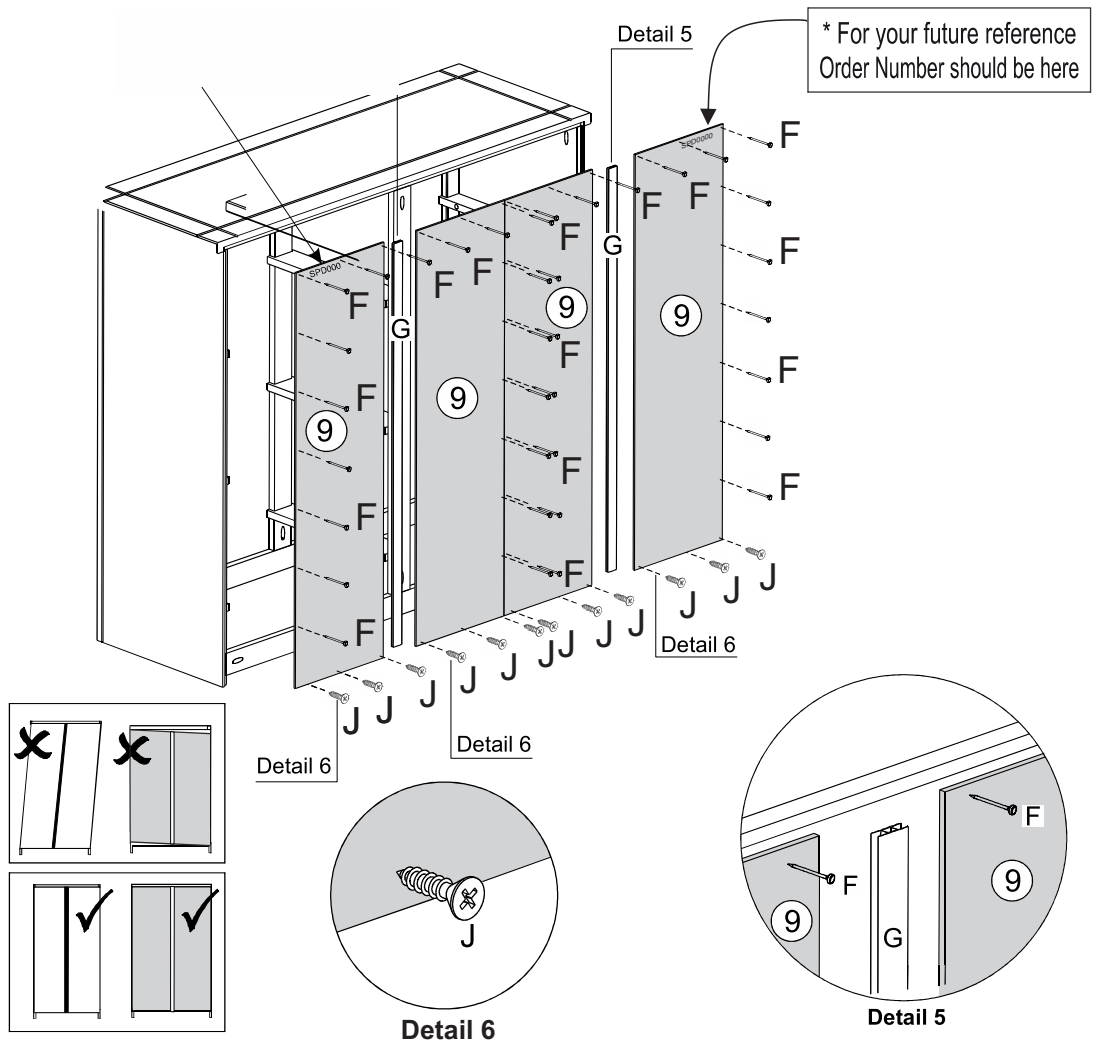
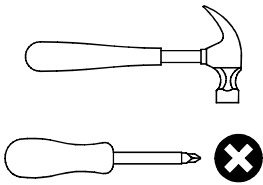

STEP 12

PARTS REQUIRED

10 - DRAWER FRONT x6

11 - DRAWER SIDE x12

HARDWARE REQUIRED

C  Ø3,0 x 30mm 24

TOOLS REQUIRED

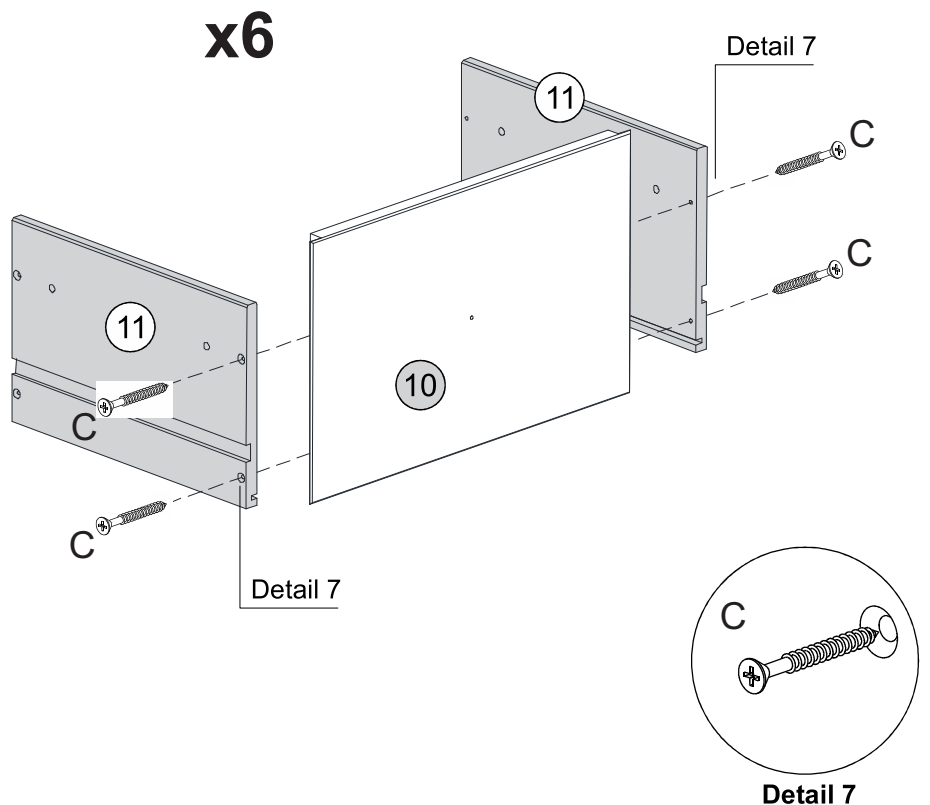
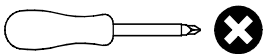

STEP 13

PARTS REQUIRED

12 -DRAWER BOTTOM x6

13 -DRAWER BACK x6

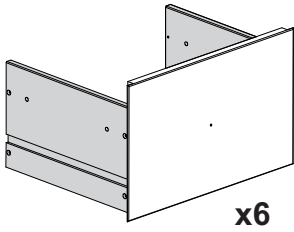

x6

HARDWARE REQUIRED

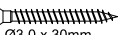
C   24
Ø3,0 x 30mm

TOOLS REQUIRED

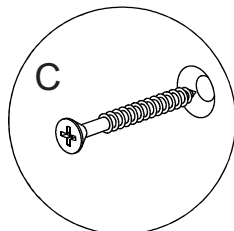
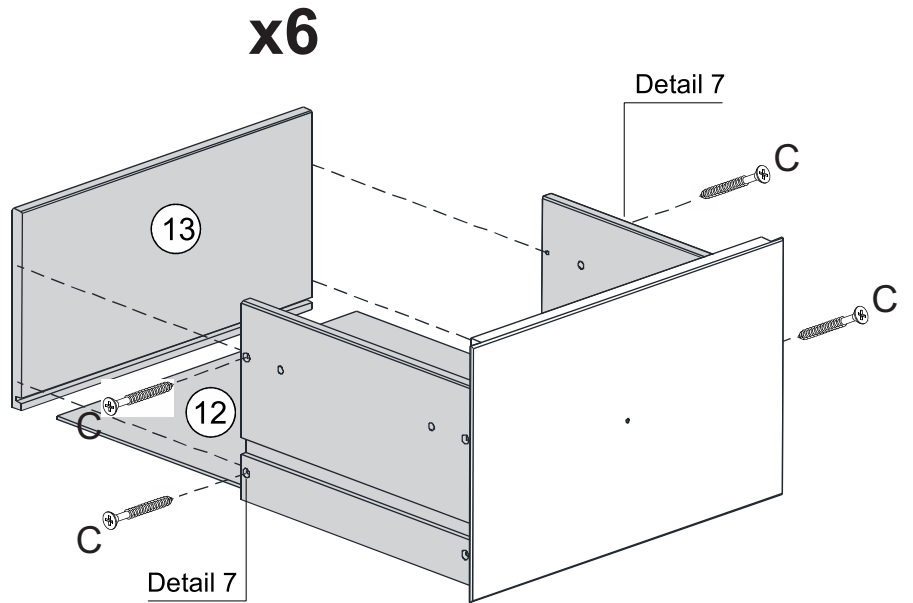
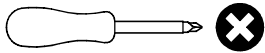

Detail 7

STEP 14

PARTS REQUIRED

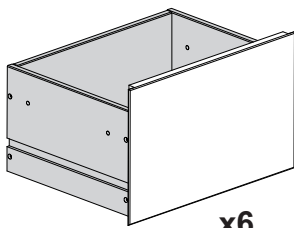

x6

HARDWARE REQUIRED

D  06

E  06
M4 x 25mm

TOOLS REQUIRED

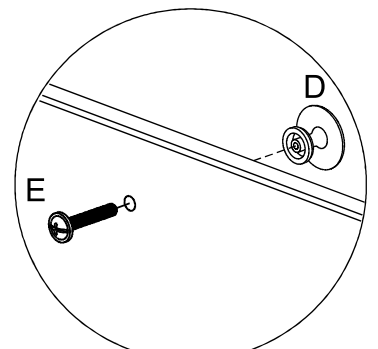
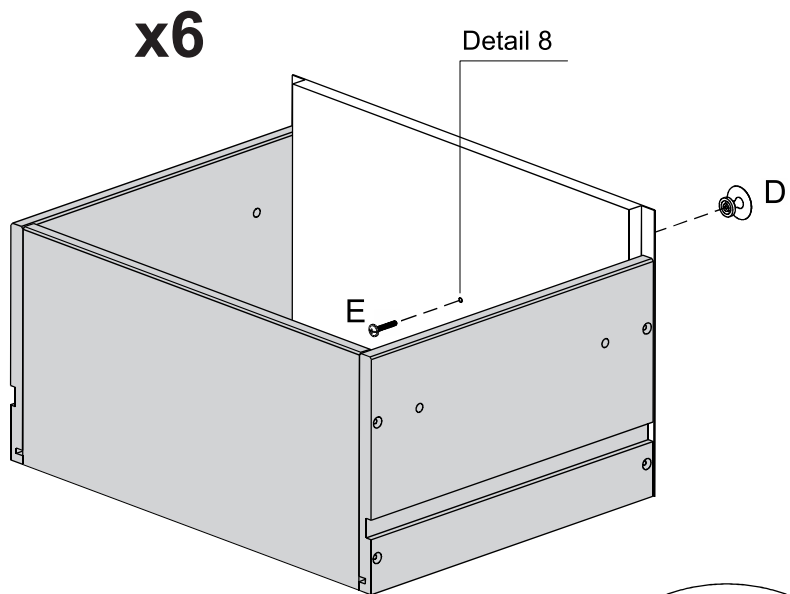
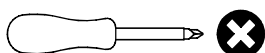

Detail 8

STEP 15

PARTS REQUIRED

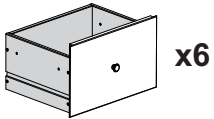
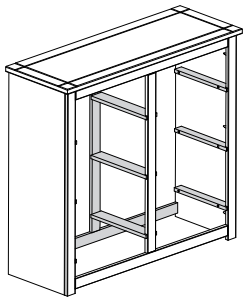

HARDWARE REQUIRED

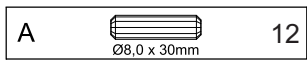

TOOLS REQUIRED

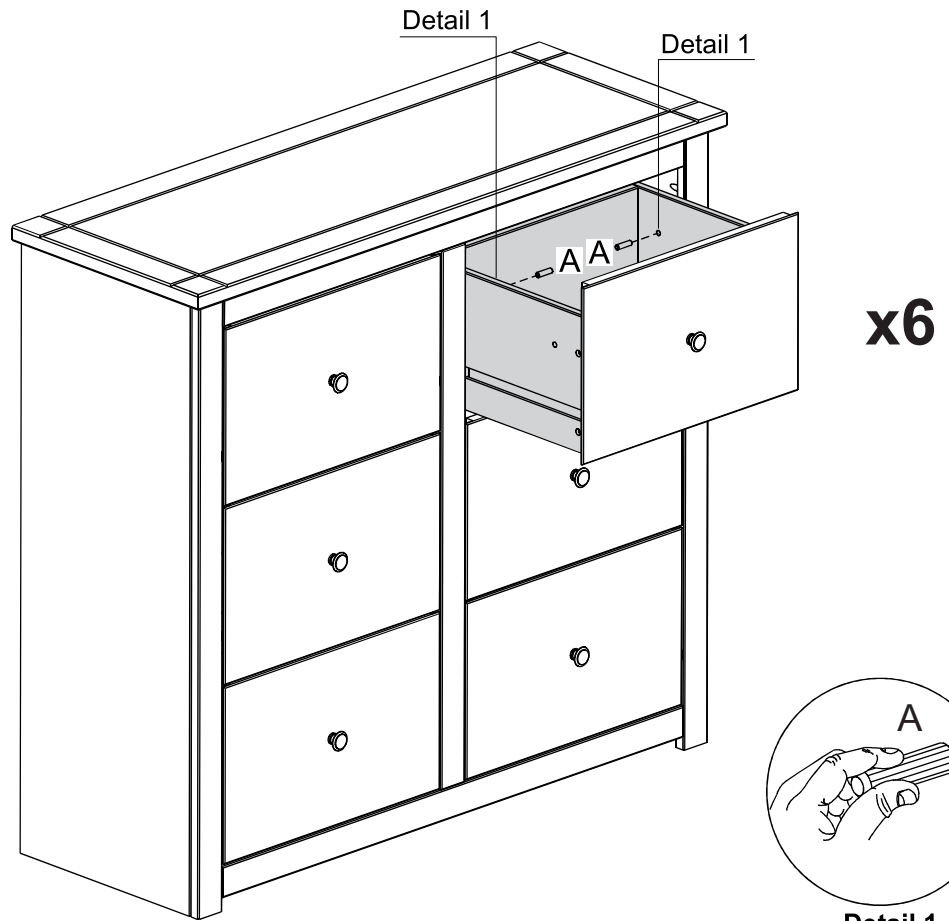
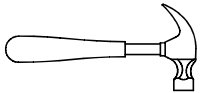

STEP 16

PARTS REQUIRED

HARDWARE REQUIRED

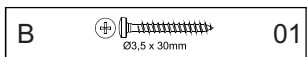

TOOLS REQUIRED

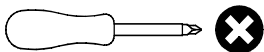

WARNING

Serious or fatal injuries can occur from furniture tipping over. To prevent the furniture from tipping over we recommend that it is permanently fixed to the wall.

Wall fixings are not supplied with this product as different wall materials require different types of fixing devices. Please make sure you use fixings suitable for the walls in your home.

