

XXXXXX(MY)

NATURAL WAX

PANAMA FLAT SCREEN TV UNIT

ASSEMBLY INSTRUCTIONS

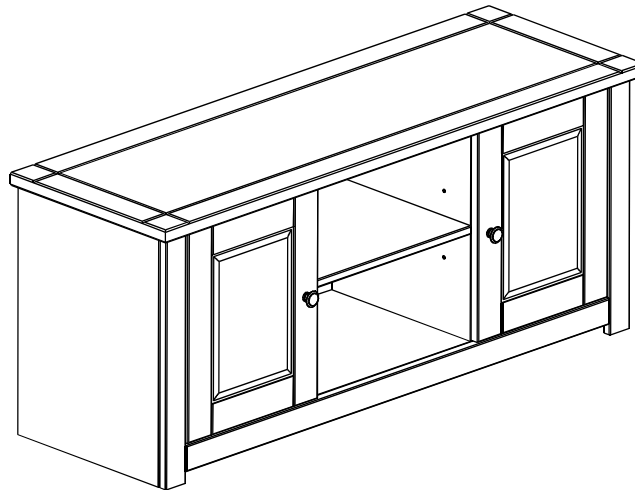

IMPORTANT FOR DOMESTIC USE ONLY

PLEASE READ BEFORE YOU CONTINUE FURTHER

CARE AND MAINTENANCE

After unpacking this product please keep the original packaging in case it needs to be returned for any reason.

- Please ensure all fittings and parts are present before commencing with assembly.
- Never drag or push products as this could cause damage to the joints making it inferior.
- We strongly recommend that you keep children away from your work area.
- We recommend that you lay a blanket or sheet on the floor to avoid damage to both your floor and the product.
- Assemble this product as close to its final position as possible.
- Do not place this product next to a radiator or in direct sunlight.
- Do not drag or push items across your high gloss furniture as this may cause the surface to scratch
- Wood is a natural product and may expand if subjected to damp and may shrink or crack if subjected to heat. Therefore it is recommended that room temperature is maintained, with no sudden temperature fluctuations.
- Make sure any spillage is wiped off immediately.
- Do not place hot or chilled items directly on to the surface, use a place mat or marking will occur.
- For general cleaning use a soft cotton or micro fibre cloth, and do not use detergents of any kind.
- From time to time it may be necessary to tighten fittings, regular inspections should be carried out.
- Do not place on a wet or damp floor as staining may occur to your floor.

TOOLS REQUIRED

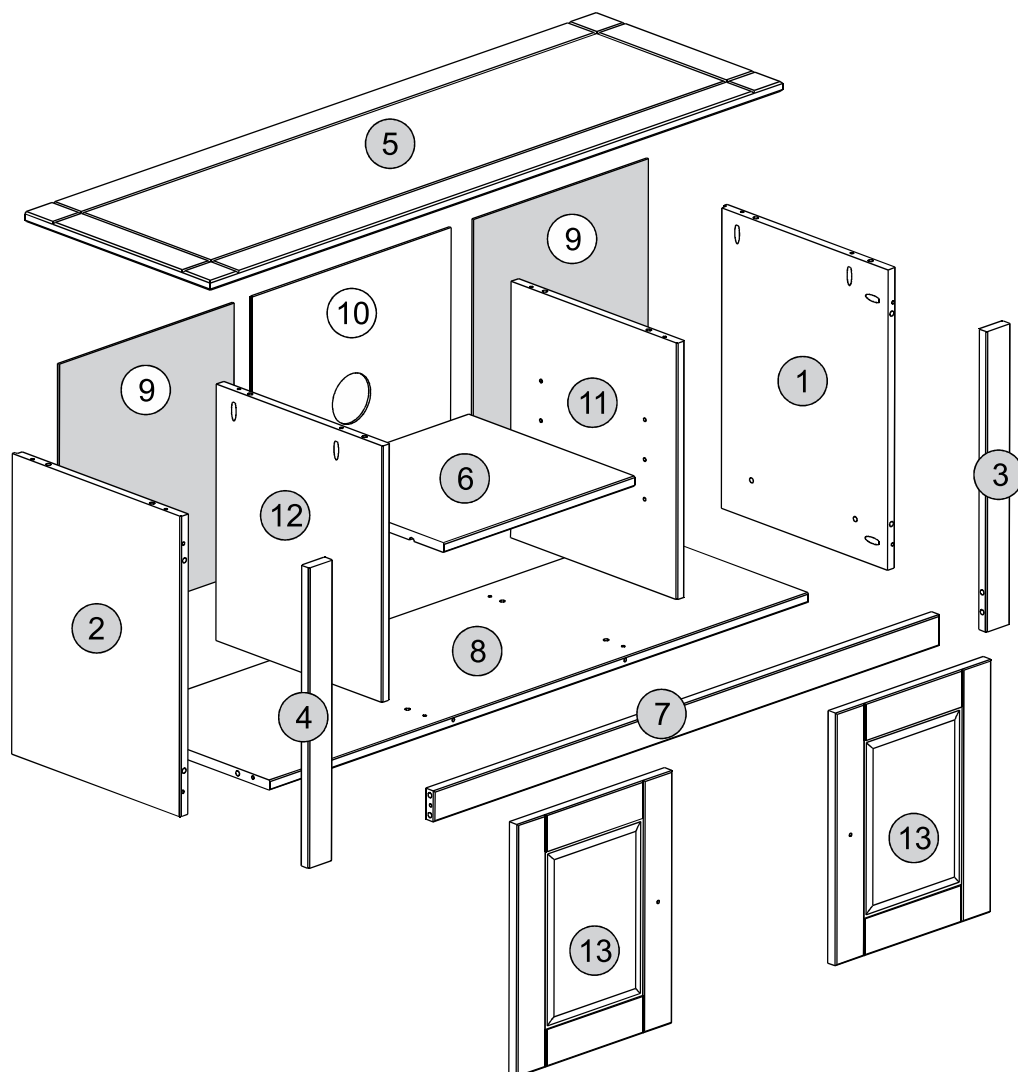
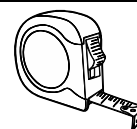
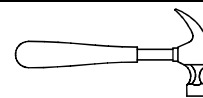
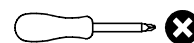







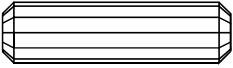

PARTS LIST

Please Note:

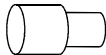
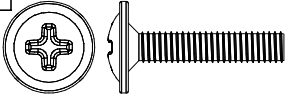
The highlighted parts below have been stamped with the part number to help identify them during assembly

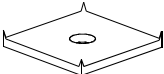
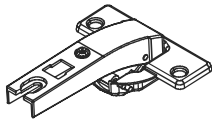
Part Number	Part Code	Part Description	Quantity	Carton
1	S300-305-019-MY1-01	Right Side Panel	1	1/1
2	S300-305-019-MY1-02	Left Side Panel	1	1/1
3	S300-305-019-MY1-03	Right Front Upright	1	1/1
4	S300-305-019-MY1-04	Left Front Upright	1	1/1
5	S300-305-019-MY1-05	Top Panel	1	1/1
6	S300-305-019-MY1-06	Shelf	1	1/1
7	S300-305-019-MY1-07	Front Crossbeam	1	1/1
8	S300-305-019-MY1-08	Base	1	1/1
9	S300-305-019-MY1-09	Back Side Panel	2	1/1
10	S300-305-019-MY1-10	Back Centre Panel	1	1/1
11	S300-305-019-MY1-11	Right Division Panel	1	1/1
12	S300-305-019-MY1-12	Left Division Panel	1	1/1
13	S300-305-019-MY1-13	Door	2	1/1

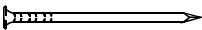
FITTINGS LIST

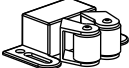
<p>A</p>  <p>+2 Dowel Ø8,0 x 30mm (24x)</p>	<p>B</p>  <p>+2 Pan Head Screw Ø3,5 x 30mm (24x)</p>	<p>C</p>  <p>+2 Flat Head Screw Ø3,5 x 14mm (24X)</p>	<p>D</p>  <p>+1 Plastic Support (4x)</p>
<p>E</p>  <p>Flan Head Screw M4 x 22mm (2x)</p>	<p>F</p>  <p>Handle (2x)</p>	<p>G</p>  <p>Catcher (4x)</p>	<p>H</p>  <p>Hinge (Right) (4x)</p>
<p>I</p>  <p>Hinge (Left) (4x)</p>	<p>J</p>  <p>+2 Nail 10x10 (26x)</p>	<p>M</p>  <p>Door Catch (3x)</p>	<p>N</p>  <p>Door Roller (3x)</p>

STEP 1

PARTS REQUIRED

1 - RIGHT SIDE PANEL x1

2 - LEFT SIDE PANEL x1

HARDWARE REQUIRED

A  08
Ø8,0 x 30mm

TOOLS REQUIRED

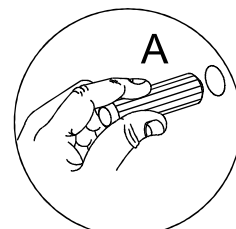
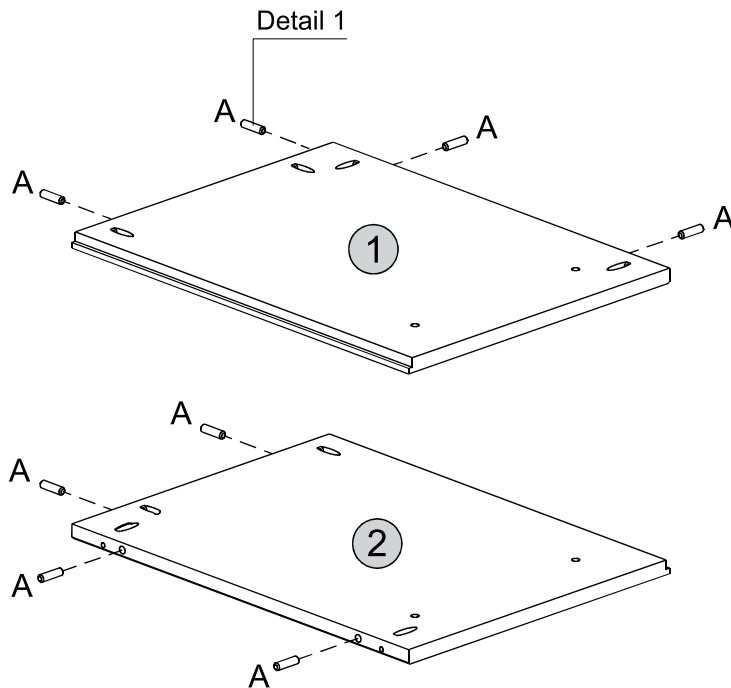
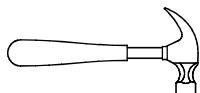

Detail 1

STEP 2

PARTS REQUIRED

1 - RIGHT SIDE PANEL x1

2 - LEFT SIDE PANEL x1

3 - RIGHT FRONT UPRIGHT x1

4 - LEFT FRONT UPRIGHT x1

HARDWARE REQUIRED

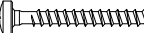
B  04
Ø3,5 x 30mm

TOOLS REQUIRED

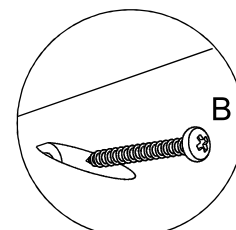
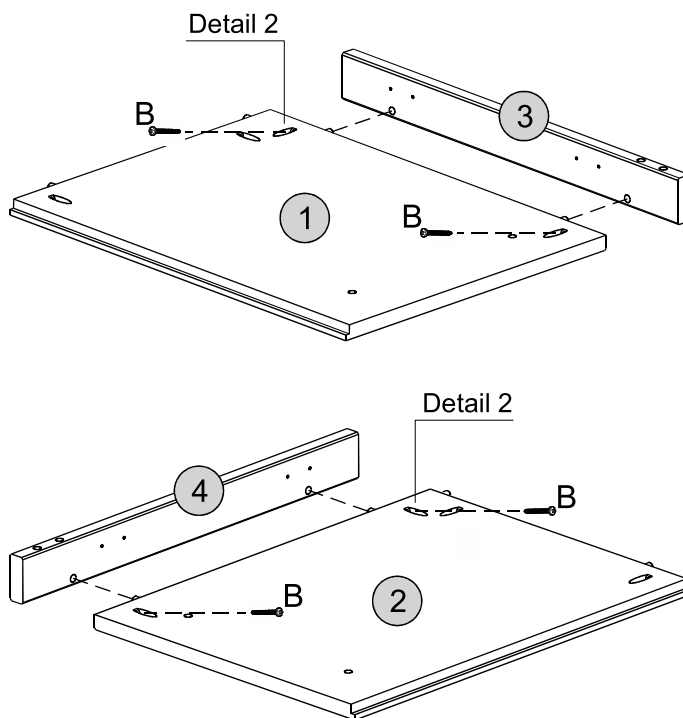
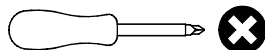

Detail 2

STEP 3

PARTS REQUIRED

1 - RIGHT SIDE PANEL x1

2 - LEFT SIDE PANEL x1

HARDWARE REQUIRED

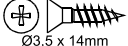
C  08
Ø3,5 x 14mm

I  04
Hinge

TOOLS REQUIRED

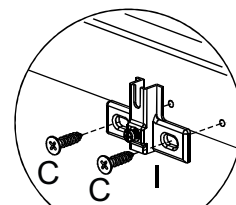
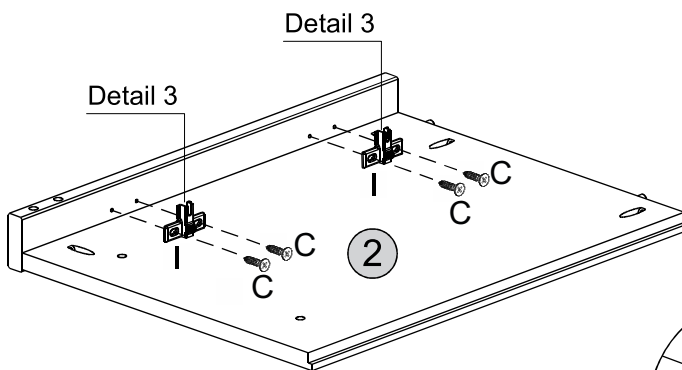
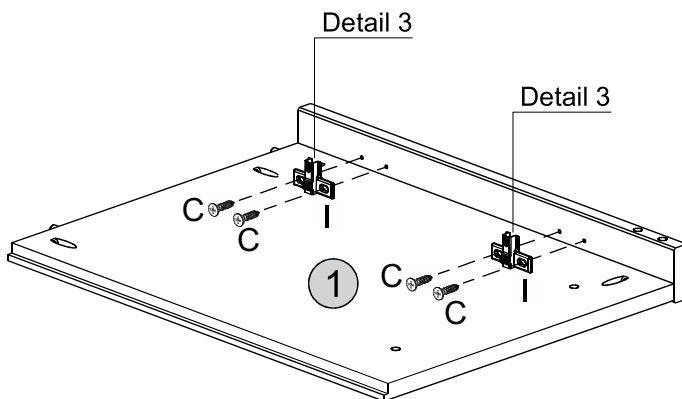
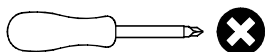

Detail 3

STEP 4

PARTS REQUIRED

7 - FRONT CROSSBEAM x1

8 - BASE x1

HARDWARE REQUIRED

A  08
Ø8,0 x 30mm

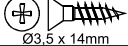
C  04
Ø3,5 x 14mm

N  02

TOOLS REQUIRED

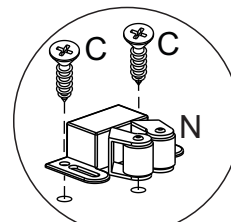
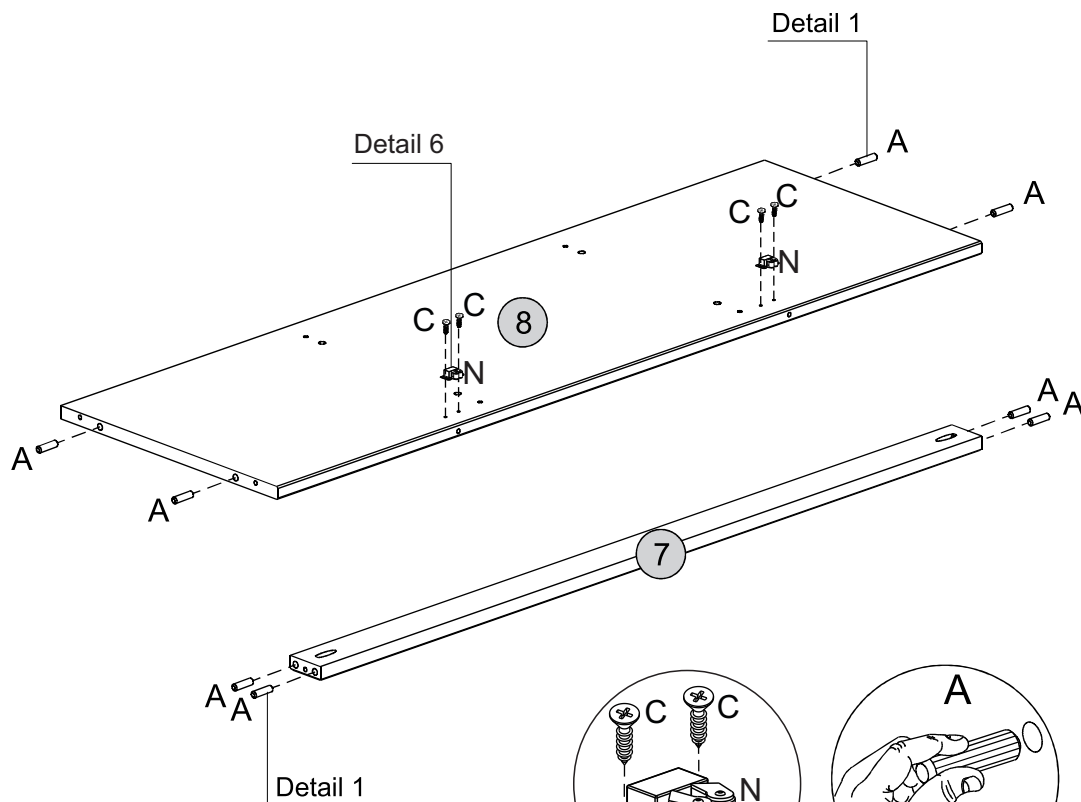
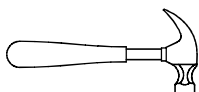

Detail 6

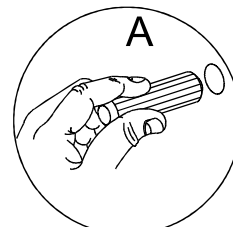

Detail 1

STEP 5

PARTS REQUIRED

7 - FRONT CROSSBEAM x1

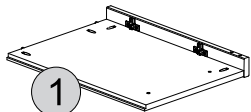

HARDWARE REQUIRED

B  01
Ø3,5 x 30mm

TOOLS REQUIRED

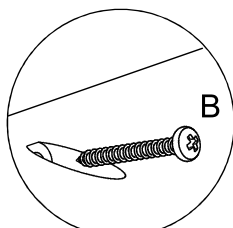
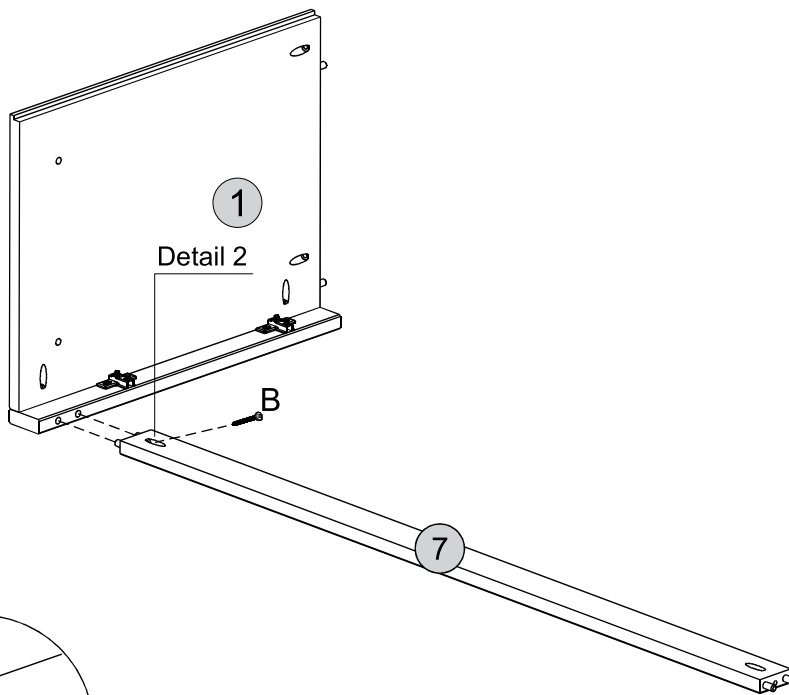
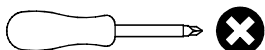

Detail 2

STEP 6

PARTS REQUIRED

8 - BASE x1

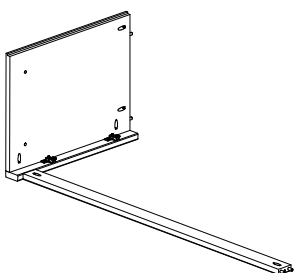

HARDWARE REQUIRED

B  02
Ø3,5 x 30mm

TOOLS REQUIRED

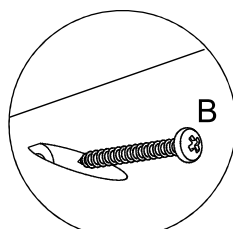
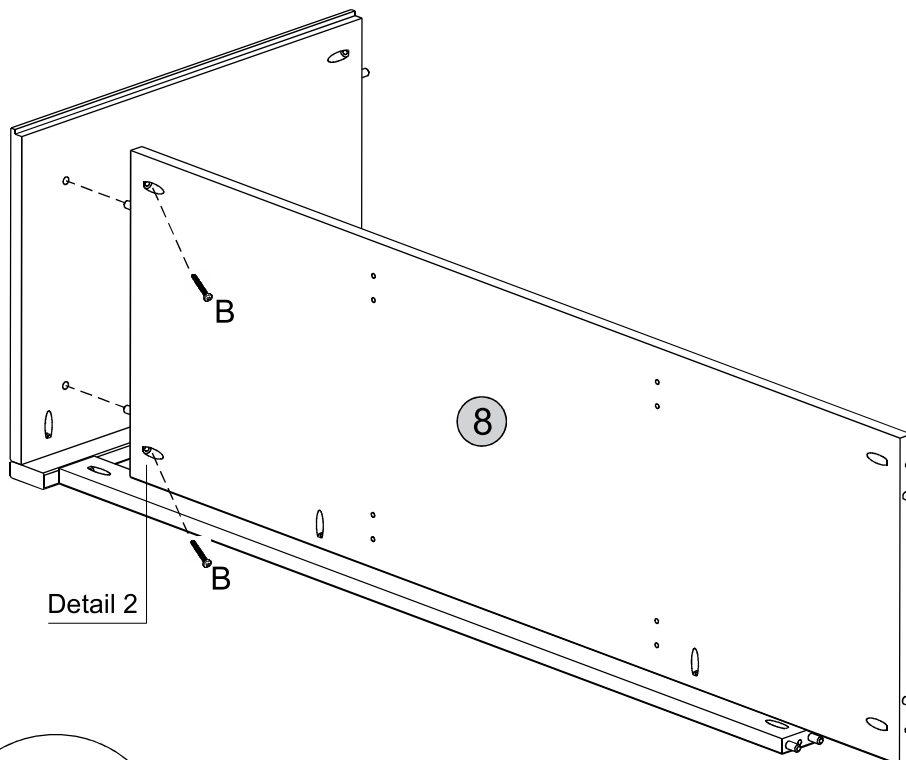
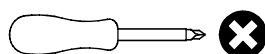

Detail 2

STEP 7

PARTS REQUIRED

2 - LEFT SIDE PANEL x1

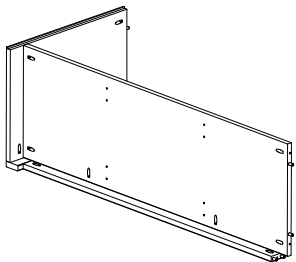

HARDWARE REQUIRED

B  05
Ø3,5 x 30mm

TOOLS REQUIRED

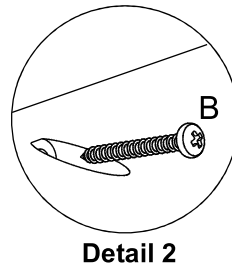
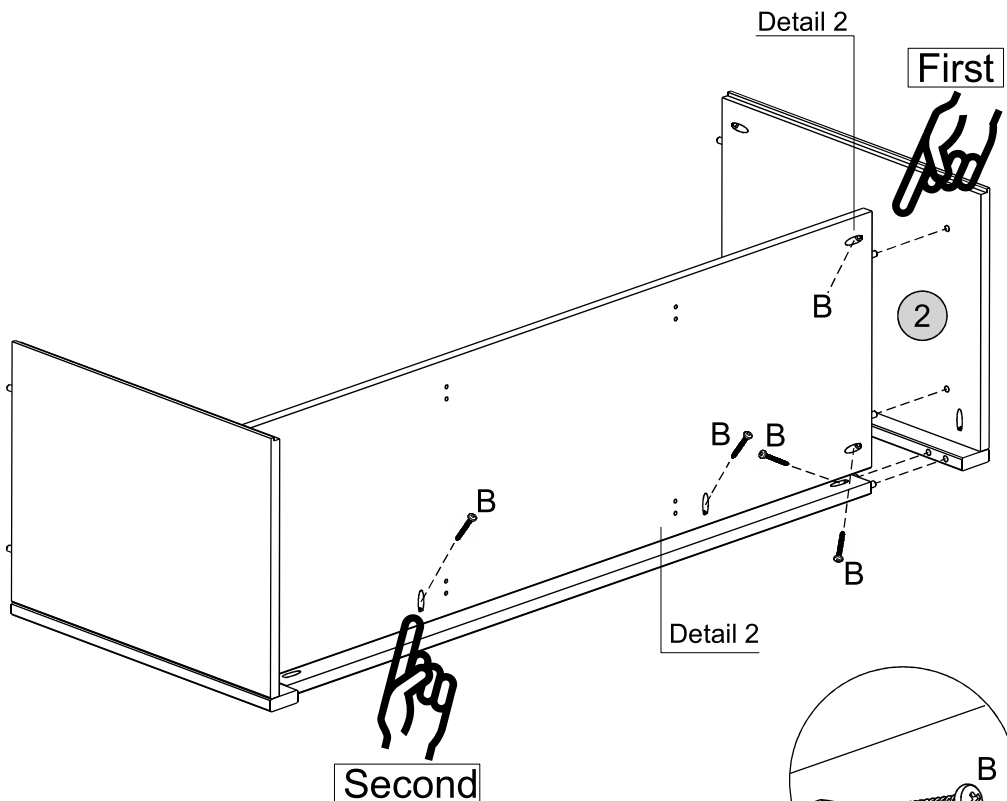
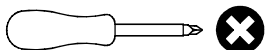

STEP 8

PARTS REQUIRED

11 - RIGHT DIVISION PANEL x1

12 - LEFT DIVISION PANEL x1

HARDWARE REQUIRED

A  08
Ø8,0 x 30mm

D  04
Plastic Support

TOOLS REQUIRED

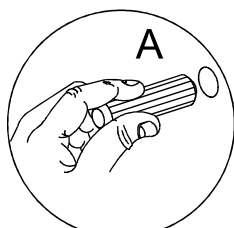
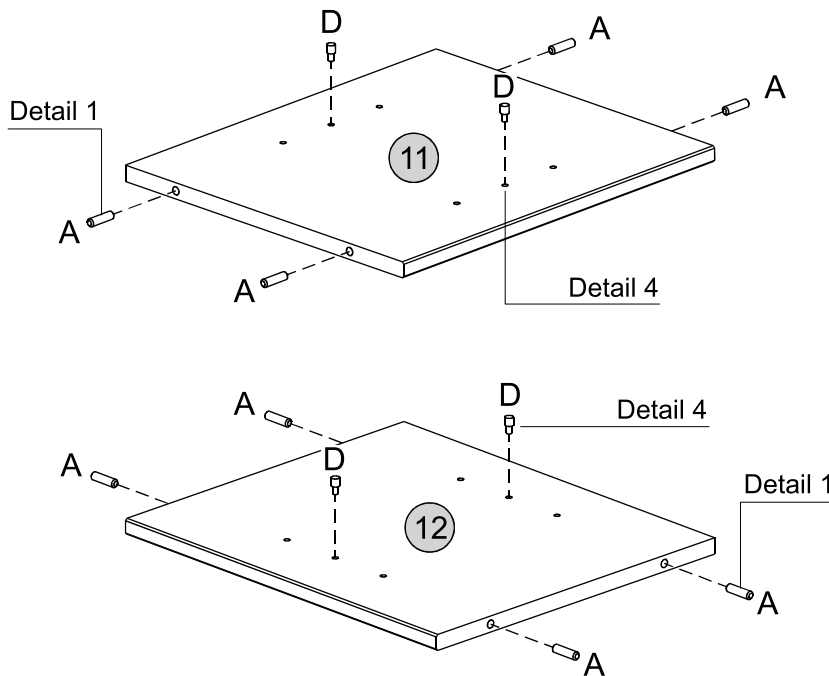
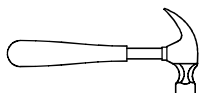

Detail 1

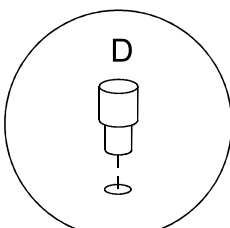

Detail 4

STEP 9

PARTS REQUIRED

- 11 - RIGHT DIVISION PANEL x1
- 12 - LEFT DIVISION PANEL x1

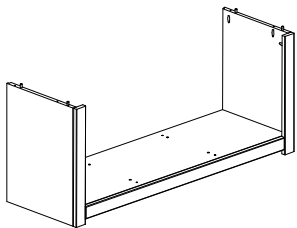

HARDWARE REQUIRED

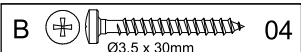

TOOLS REQUIRED

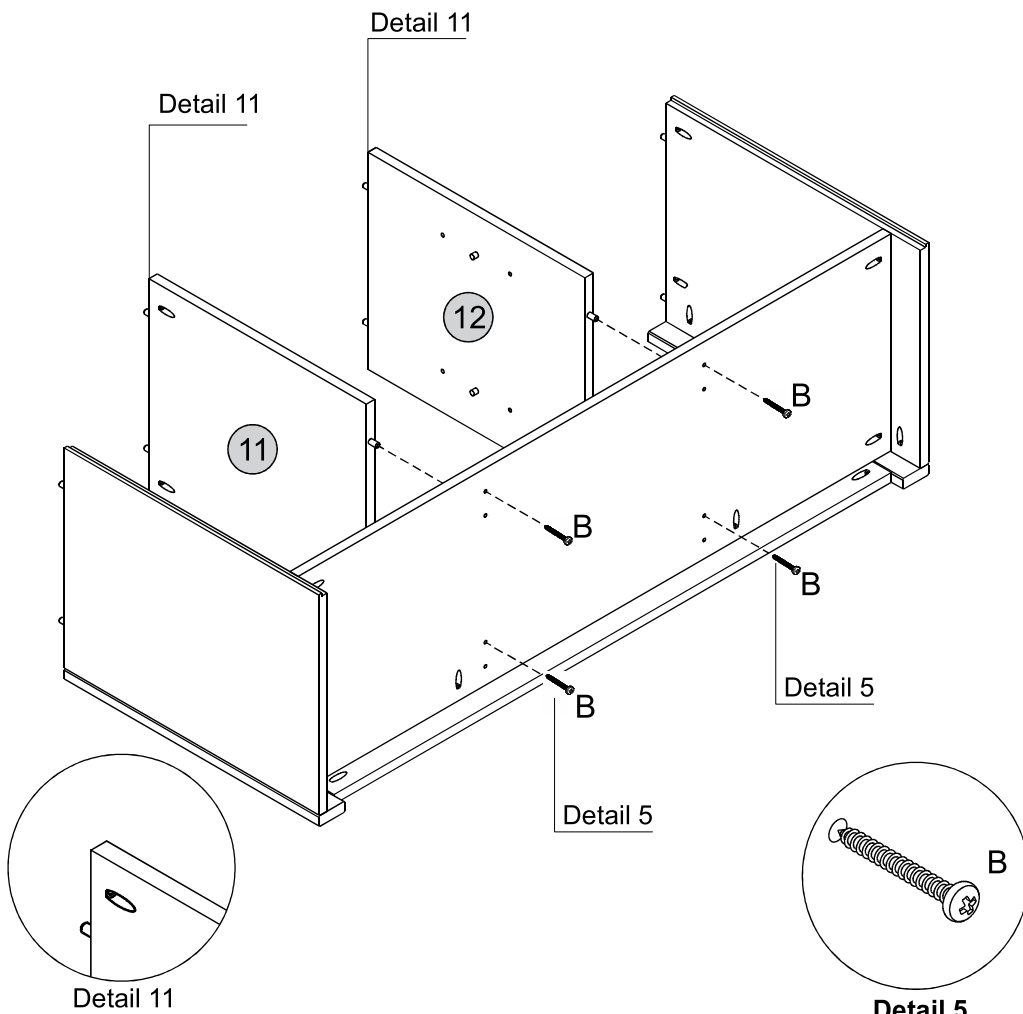
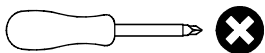

STEP 10

PARTS REQUIRED

- 5 - TOP PANEL x1

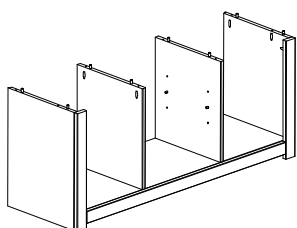

HARDWARE REQUIRED

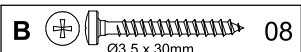

TOOLS REQUIRED

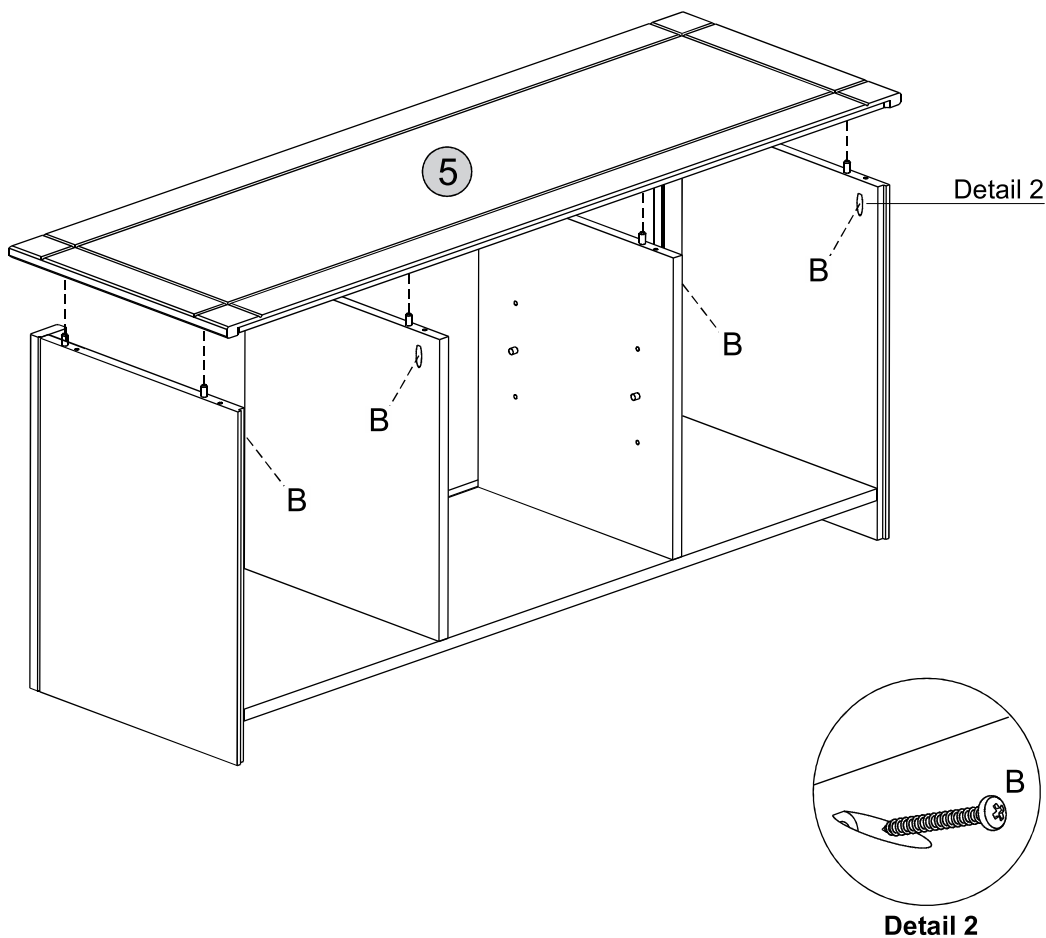
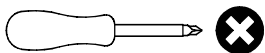

STEP 11

PARTS REQUIRED

9 - BACK PANEL	x2
10 - BACK CENTRE PANEL	x1

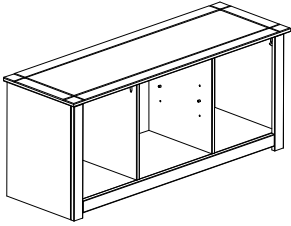

HARDWARE REQUIRED

J		26
G		04

* For your future reference
Order Number should be here

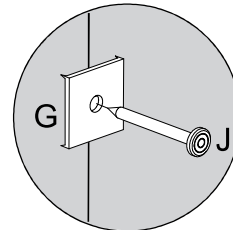
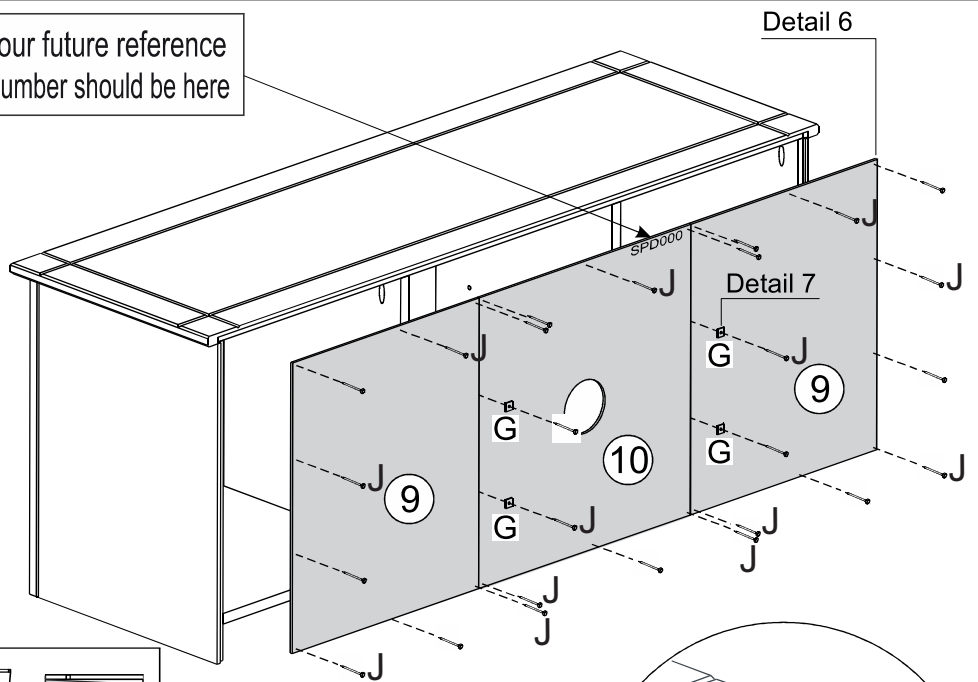
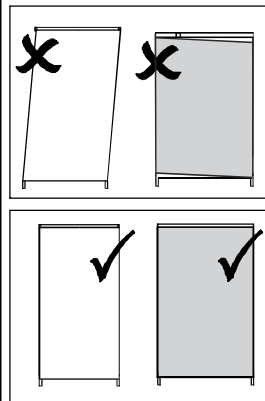

Detail 7

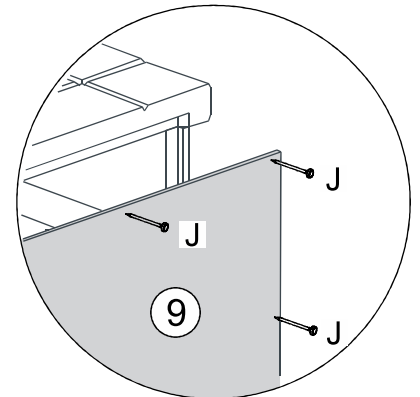

Detail 6

STEP 12

PARTS REQUIRED

13 - DOOR	x2
-----------	----

HARDWARE REQUIRED

C		08
H		04

TOOLS REQUIRED

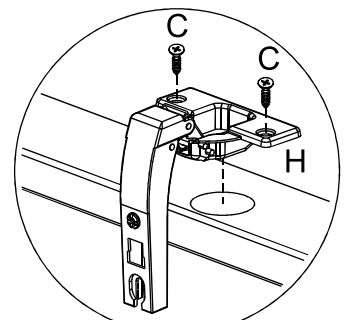
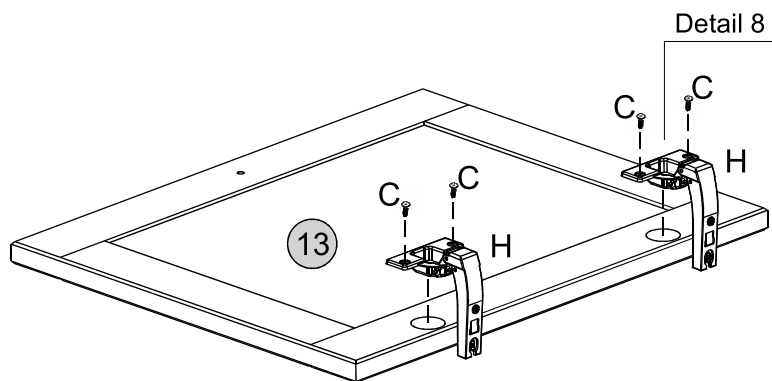
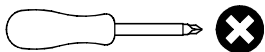

Detail 8

STEP 13

PARTS REQUIRED

6 - SHELF x1

13 - DOOR x2

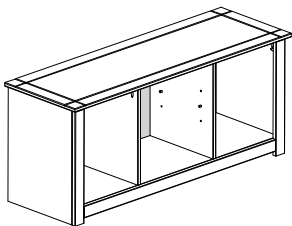

HARDWARE REQUIRED

C  04
Ø3,5 x 14mm

E  02
M4 x 22mm

F  02

M  02

TOOLS REQUIRED

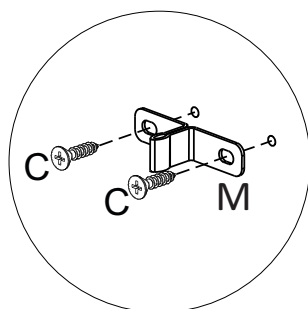
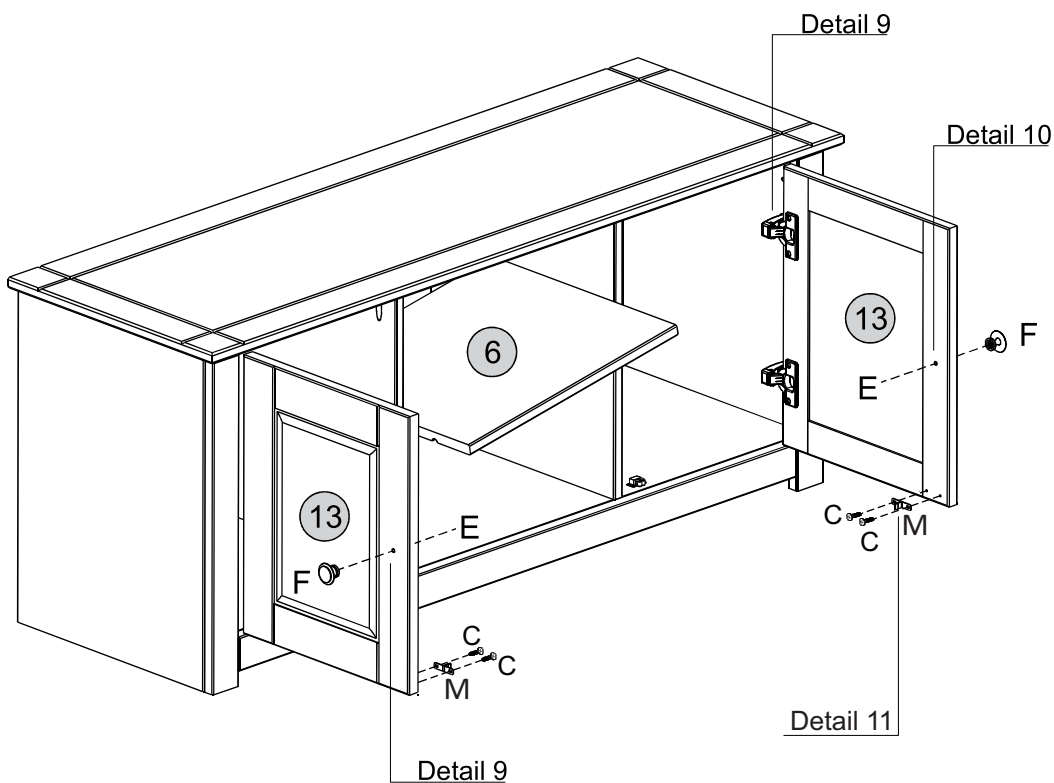
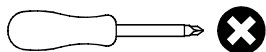

Detail 11

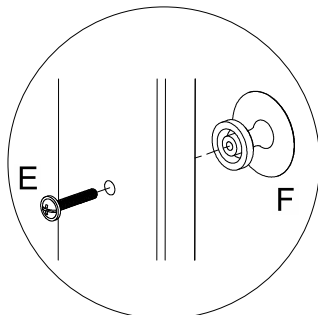

Detail 10

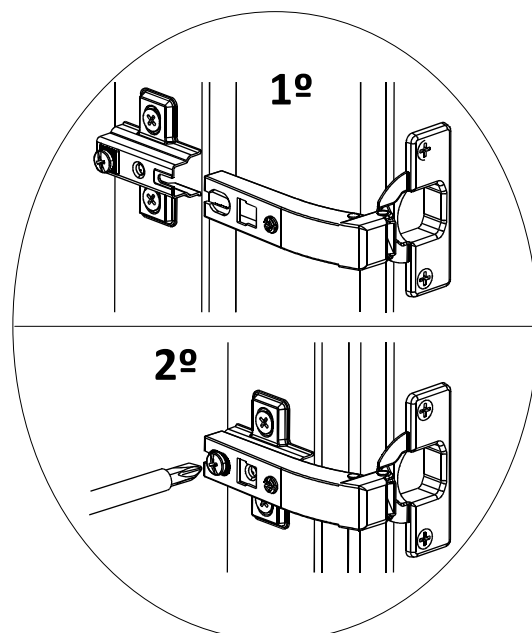

Detail 9

ADJUSTMENTS

