

WHITE MALVERN 3 DRAWER CHEST ASSEMBLY INSTRUCTIONS

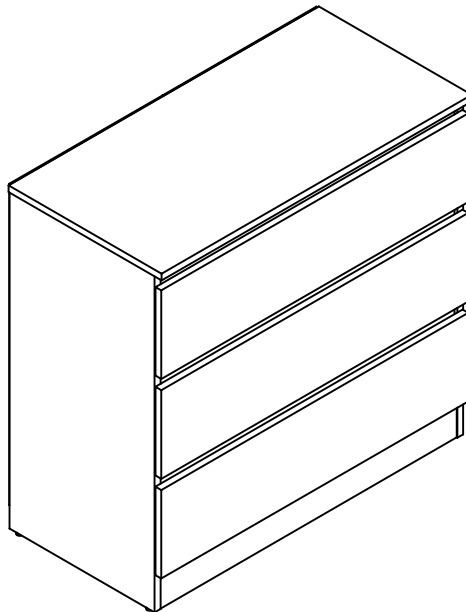

FOR DOMESTIC USE ONLY

IMPORTANT

PLEASE READ BEFORE YOU CONTINUE FURTHER

THE PRODUCT YOU HAVE PURCHASED WILL GIVE YOU MANY YEARS OF SERVICE IF YOU FOLLOW THE GUIDELINES FOR ITS SAFE ASSEMBLY AND PERIODIC MAINTENANCE AND CLEANING.

ASSEMBLE ON A SOFT CLEAN SURFACE.

DO NOT USE ANY TOOLS OTHER THAN THOSE SHOWN.

ANY SPANNERS OR ALLEN KEYS REQUIRED ARE INCLUDED WITH THE FITTING KIT.

DO NOT FOR ANY REASON USE A POWER TOOL TO ASSEMBLE THIS PRODUCT. ITS USE WILL INVALIDATE ANY CLAIM YOU MAY HAVE AND COULD MAKE THIS PRODUCT UNSAFE.

DEPENDING ON THE AMOUNT OF USE THIS PRODUCT RECEIVES. IT MAY BE NECESSARY TO TIGHTEN UP THE FIXINGS FROM TIME TO TIME. THIS IS COMPLETELY NORMAL FOR ANY FLAT PACK FURNITURE. DO NOT OVERTIGHTEN FIXINGS.

FOR CLEANING, YOU MAY USE A DAMP CLOTH (NOT WET). DO NOT USE POLISH, DETERGENT OR CHEMICAL CLEANERS.

THIS SURFACE OF THIS ITEM IS NOT HEAT RESISTANT. ALWAYS USE A PLACE MAT UNDER HOT OR COLD ITEMS TO PREVENT MARKING.

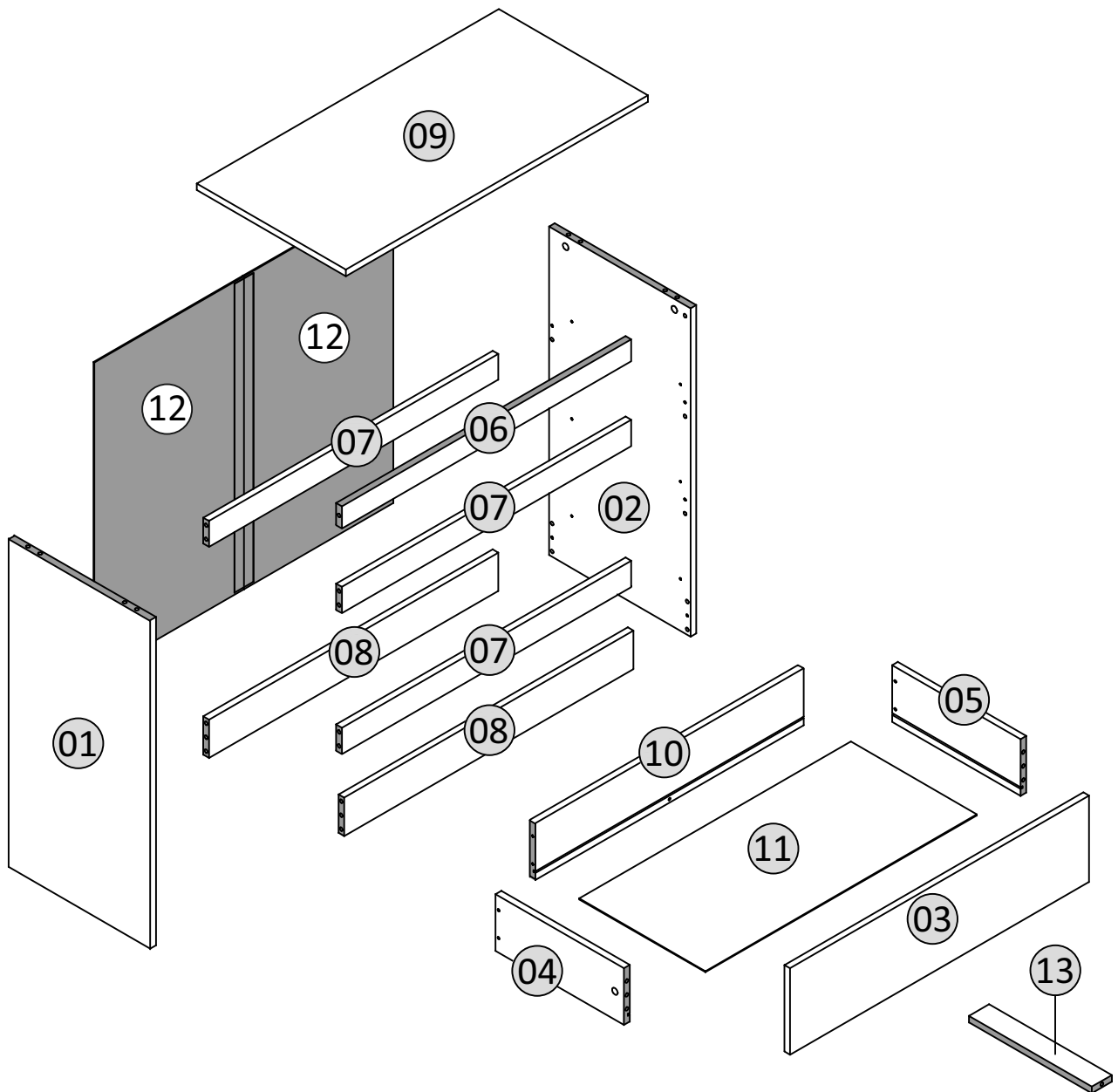

PART LIST

<u>Part Number</u>	<u>Part Code</u>	<u>Part Description</u>	<u>Quantity</u>	<u>Carton</u>
01	S100-102-136-ZF1-01	Left Panel	1	1/1
02	S100-102-136-ZF1-02	Right Panel	1	1/1
03	S100-102-136-ZF1-03	Drawer Front	3	1/1
04	S100-102-136-ZF1-04	Drawer Left Panel	3	1/1
05	S100-102-136-ZF1-05	Drawer Right Panel	3	1/1
06	S100-102-136-ZF1-06	Top Support Panel	1	1/1
07	S100-102-136-ZF1-07	Centre Support Panel	3	1/1
08	S100-102-136-ZF1-08	Bottom Support Panel	2	1/1
09	S100-102-136-ZF1-09	Top Panel	1	1/1
10	S100-102-136-ZF1-10	Drawer Back Panel	3	1/1
11	S100-102-136-ZF1-11	Drawer Bottom Panel	3	1/1
12	S100-102-136-ZF1-12	Back Panel	2	1/1
13	S100-102-136-ZF1-13	Drawer Support Panel	3	1/1

HARDWARE LIST

No.	Part Name		Qty
A	Cam Nut		23
B	Cam Bolt		23
C	M8 x 25mm Wood Dowel		32
D	38mm Chipboard Screw		15
E	14mm Chipboard Screw		34
F	14" Drawer Slide		3 sets
G	PVC L Braket		1
H	Plastic Foot		4
J	18mm Panel Pin		40
K	Wall Fittings (4 x 20mm x 1)		1

TIPS FOR FITTING CAM-LOCKS

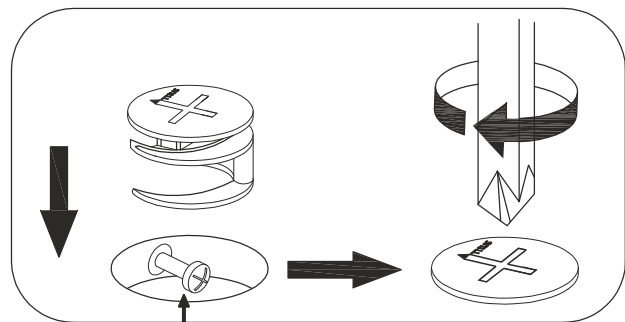
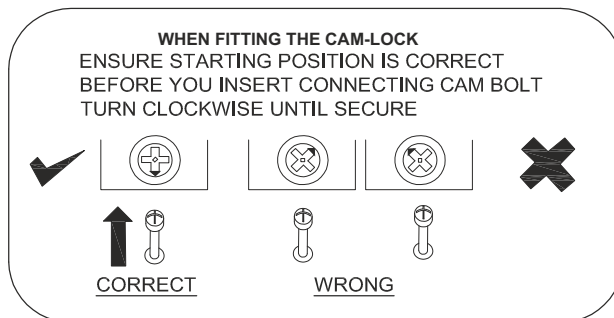

Cam bolt head needs to be in centre

CAMBOLT

Tighten until shoulder is flush with panel. Do not overtighten or undertighten (see example below)

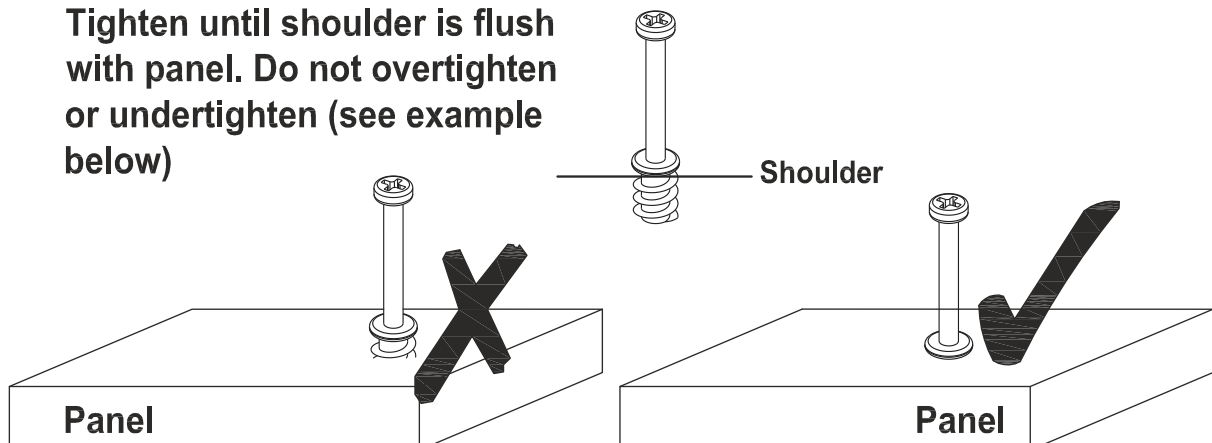

STEP 1

PARTS REQUIRED

01 - LEFT PANEL x1

HARDWARE REQUIRED

E  09

F  03

TOOLS REQUIRED

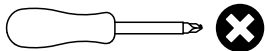

To Assemble the Drawer Slide, Please Follow Step as Below

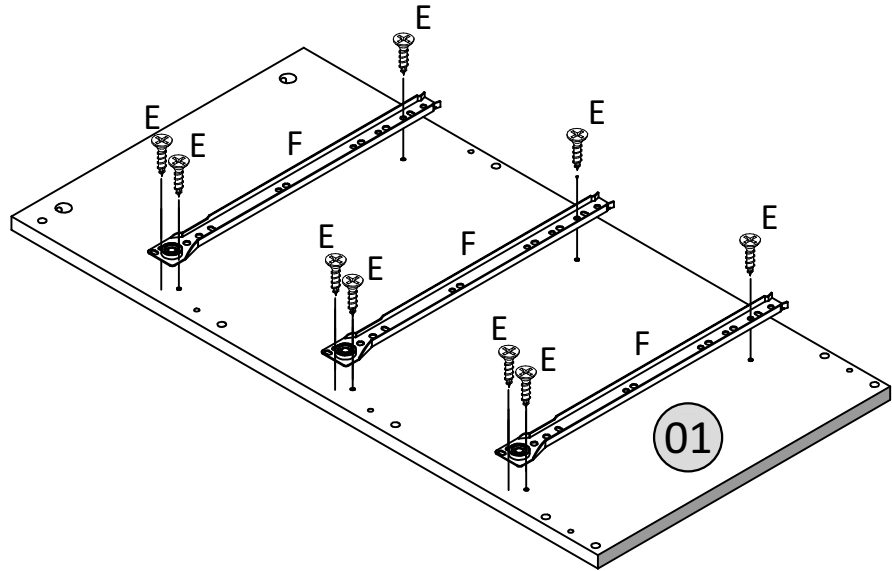

STEP 2

PARTS REQUIRED

02 - RIGHT PANEL x1

HARDWARE REQUIRED

E  09

F  03

TOOLS REQUIRED

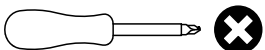

To Assemble the Drawer Slide, Please Follow Step as Below

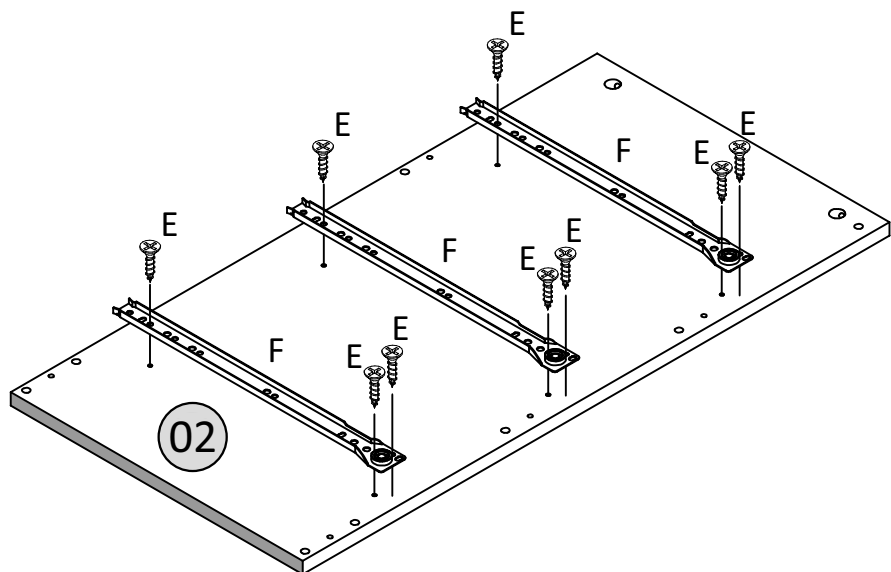



STEP 3

PARTS REQUIRED

01 - LEFT PANEL	x1
02 - RIGHT PANEL	x1

HARDWARE REQUIRED

A		04
B		10
C		04

TOOLS REQUIRED

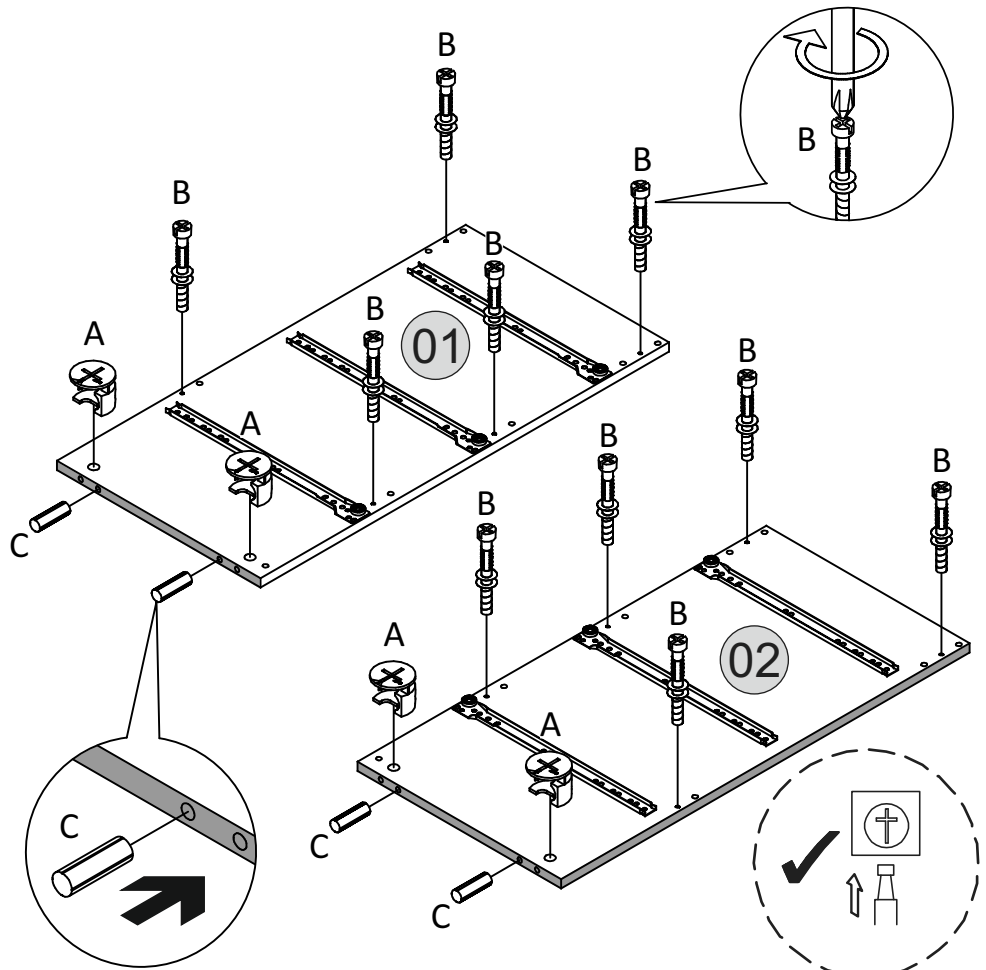
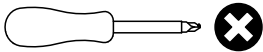



STEP 4

PARTS REQUIRED

06 - TOP SUPPORT PANEL	x1
07 - CENTRE SUPPORT PANEL	x3
08 - BOTTOM SUPPORT PANEL	x2
09 - TOP PANEL	x1

HARDWARE REQUIRED

A		10
B		04
C		16

TOOLS REQUIRED

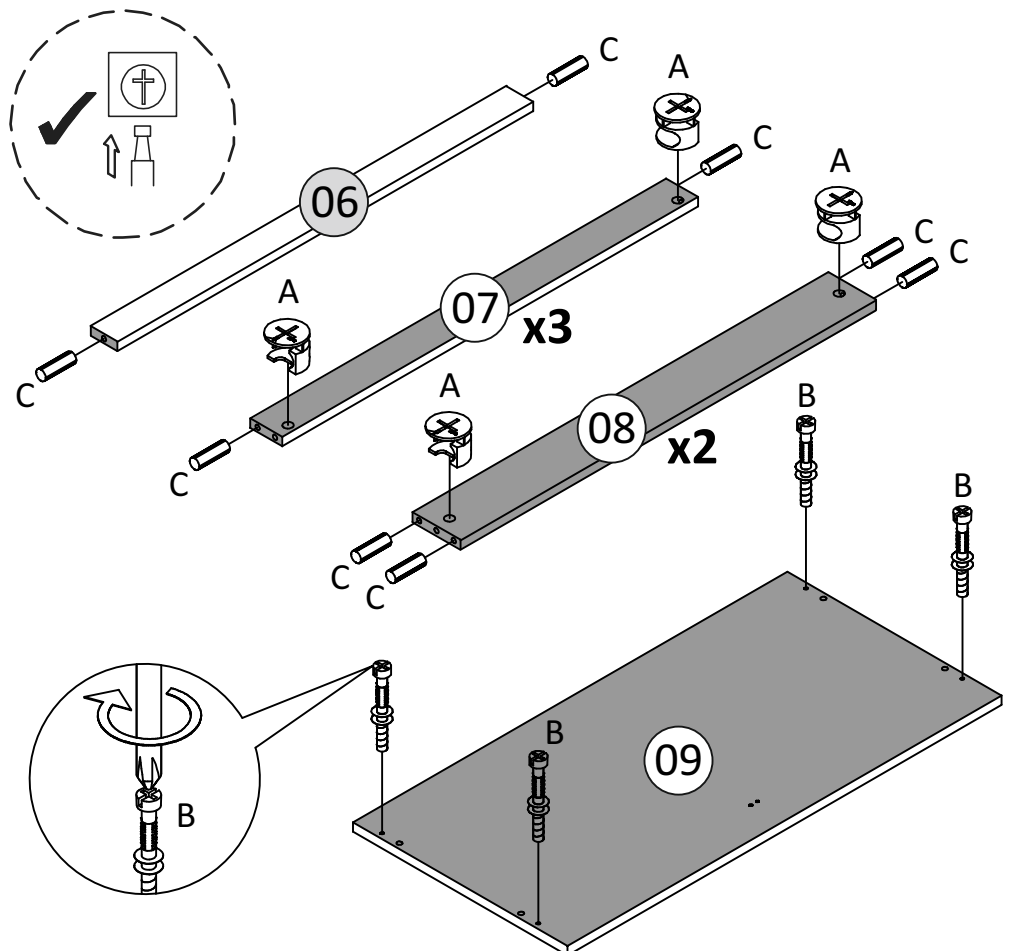
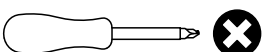

STEP 5

PARTS REQUIRED

- 02 - RIGHT PANEL x1
- 06 - TOP SUPPORT PANEL x1
- 07 - CENTRE SUPPORT PANEL x3
- 08 - BOTTOM SUPPORT PANEL x2

HARDWARE REQUIRED

TOOLS REQUIRED

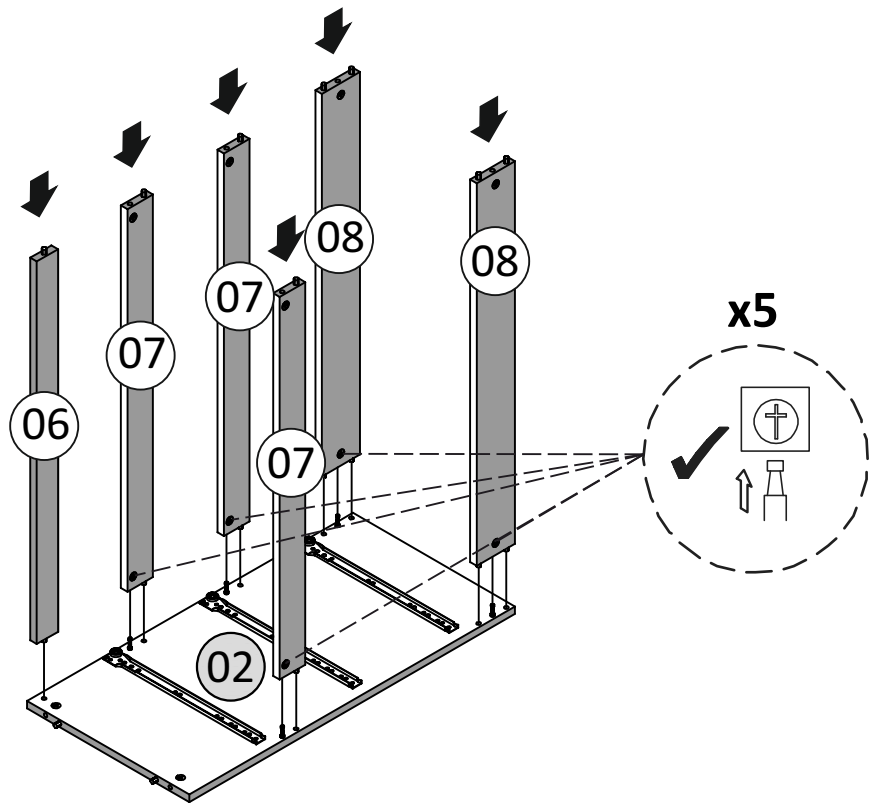
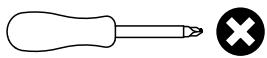

STEP 6

PARTS REQUIRED

- 01 - LEFT PANEL x1

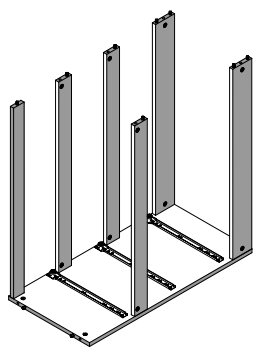

HARDWARE REQUIRED

TOOLS REQUIRED

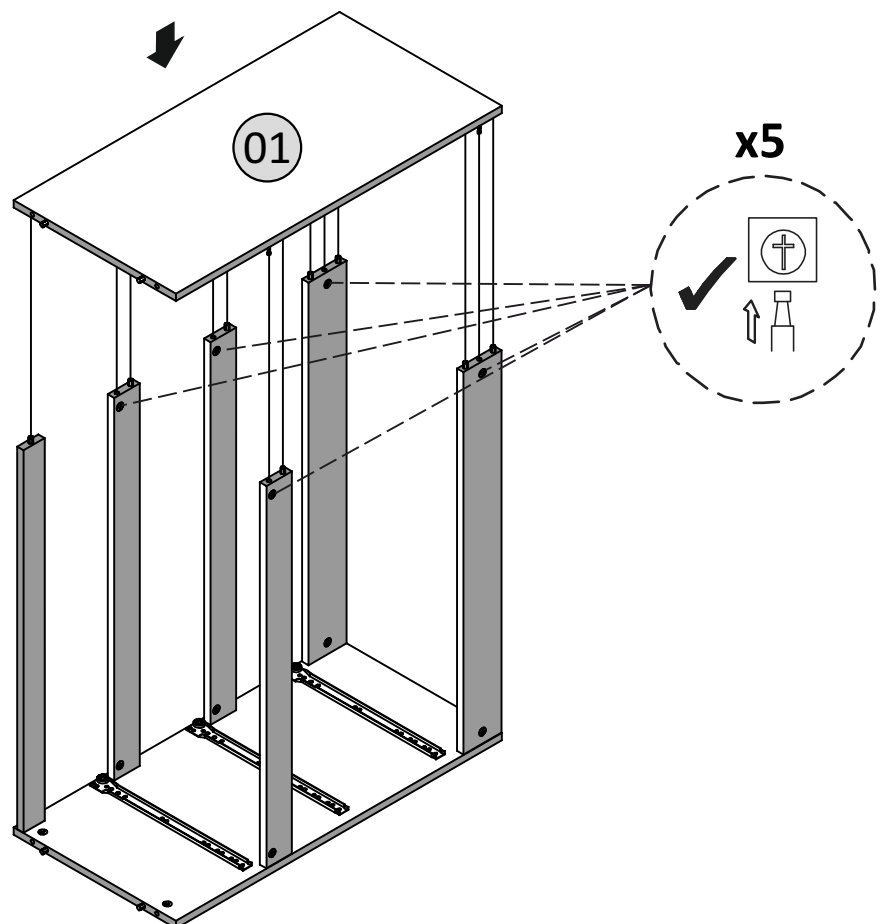
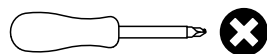

STEP 7

PARTS REQUIRED

09 - TOP PANEL x1

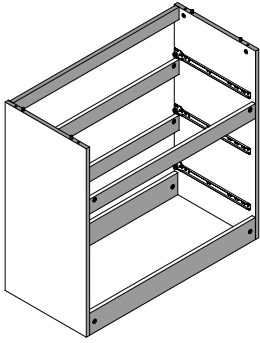

HARDWARE REQUIRED

TOOLS REQUIRED

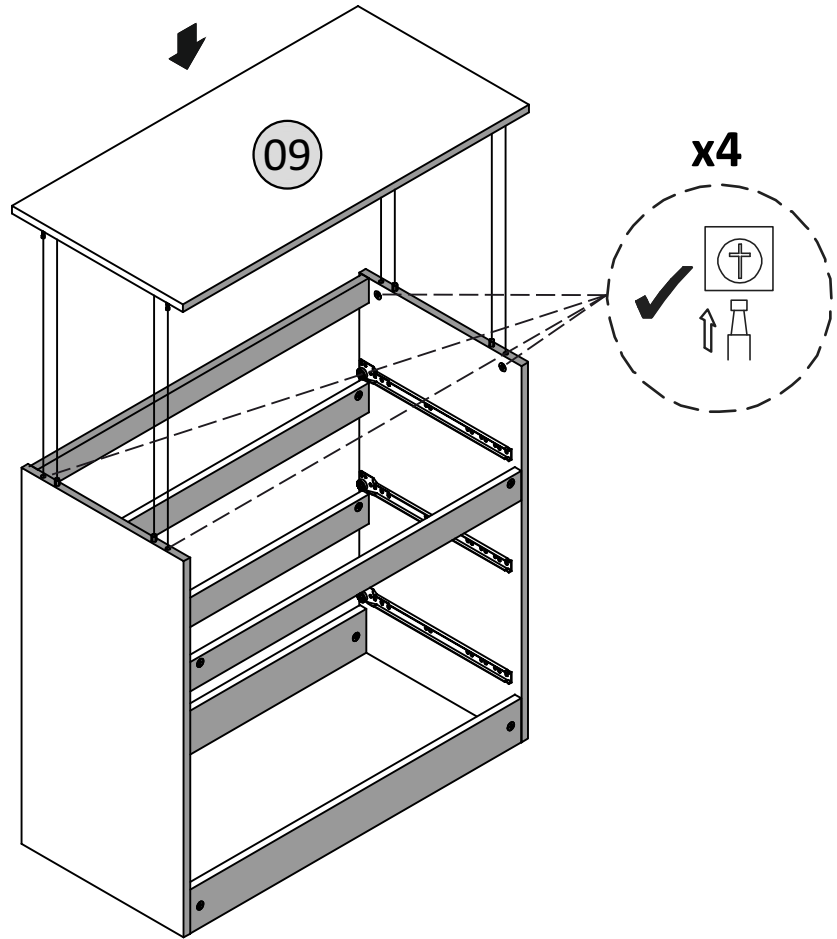
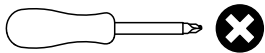

STEP 8

PARTS REQUIRED

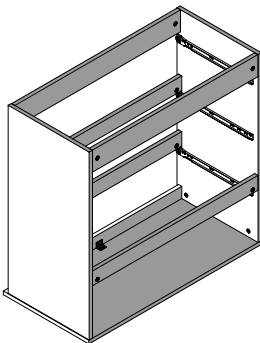

HARDWARE REQUIRED

E  04

G  01

TOOLS REQUIRED

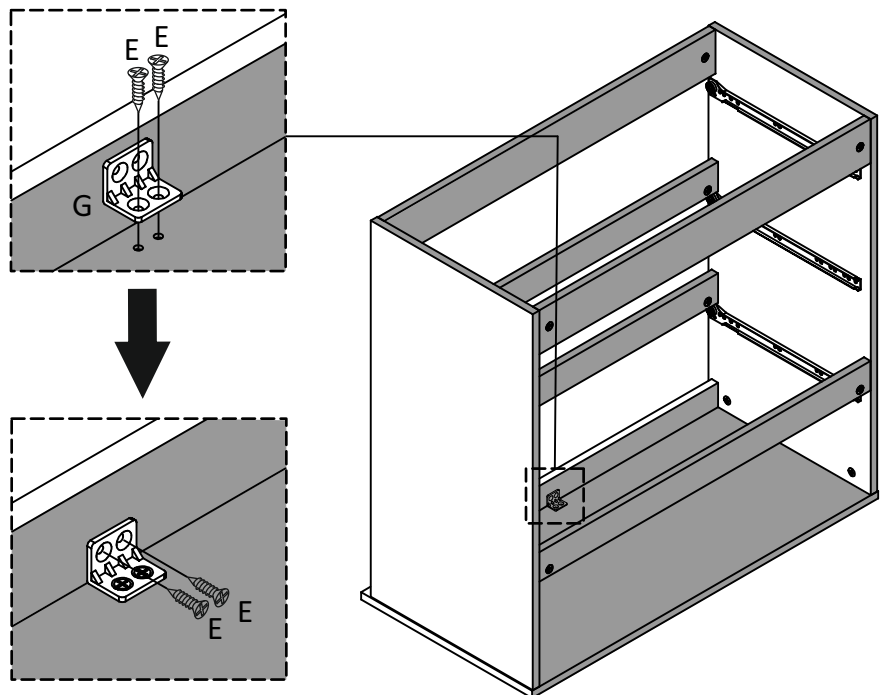
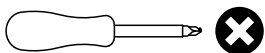

STEP 9

PARTS REQUIRED

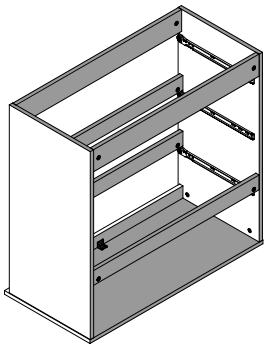

HARDWARE REQUIRED



TOOLS REQUIRED

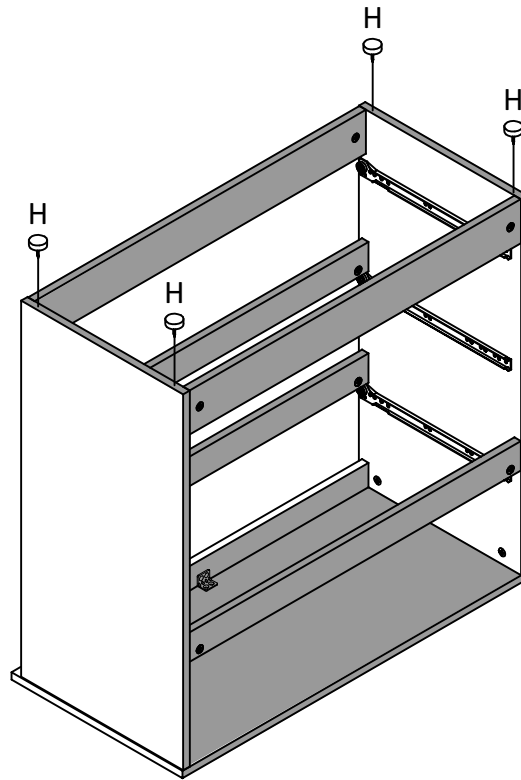
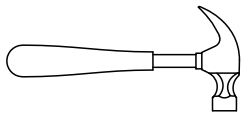

STEP 10

PARTS REQUIRED

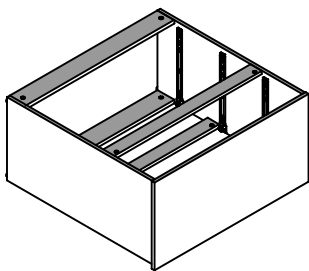
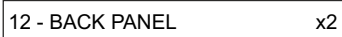

HARDWARE REQUIRED

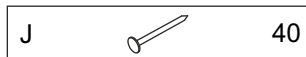

TOOLS REQUIRED

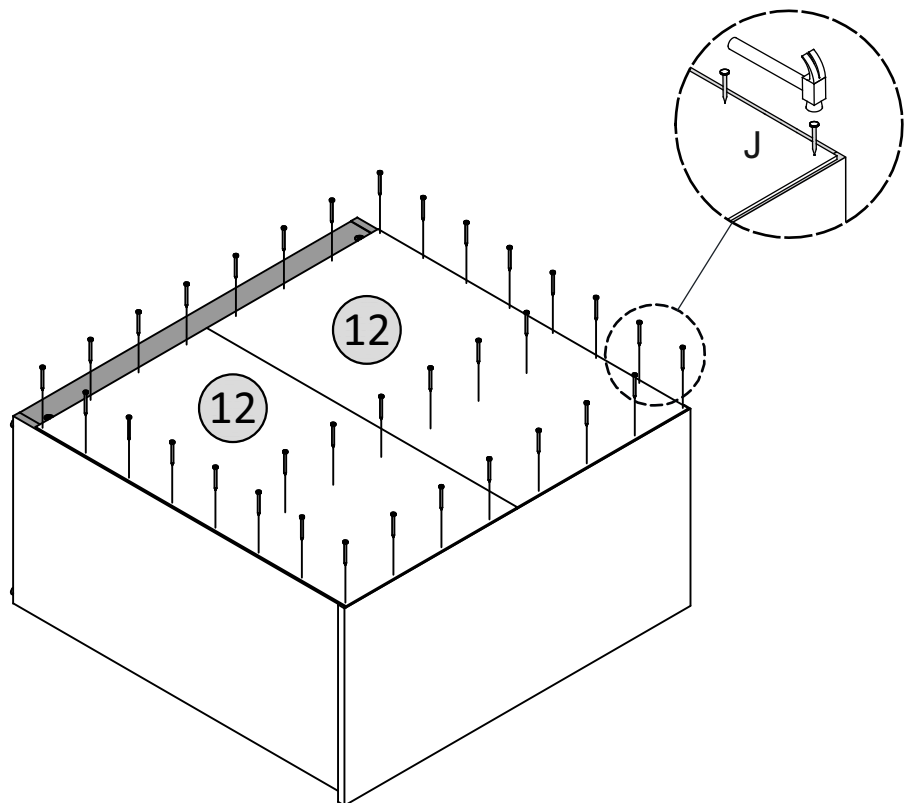
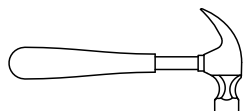



STEP 11

PARTS REQUIRED

- 03 - DRAWER FRONT x3
- 04 - DRAWER LEFT PANEL x3
- 05 - DRAWER RIGHT PANEL x3
- 13 - DRAWER SUPPORT PANEL x3

HARDWARE REQUIRED

- A  09
- B  09
- C  12

TOOLS REQUIRED

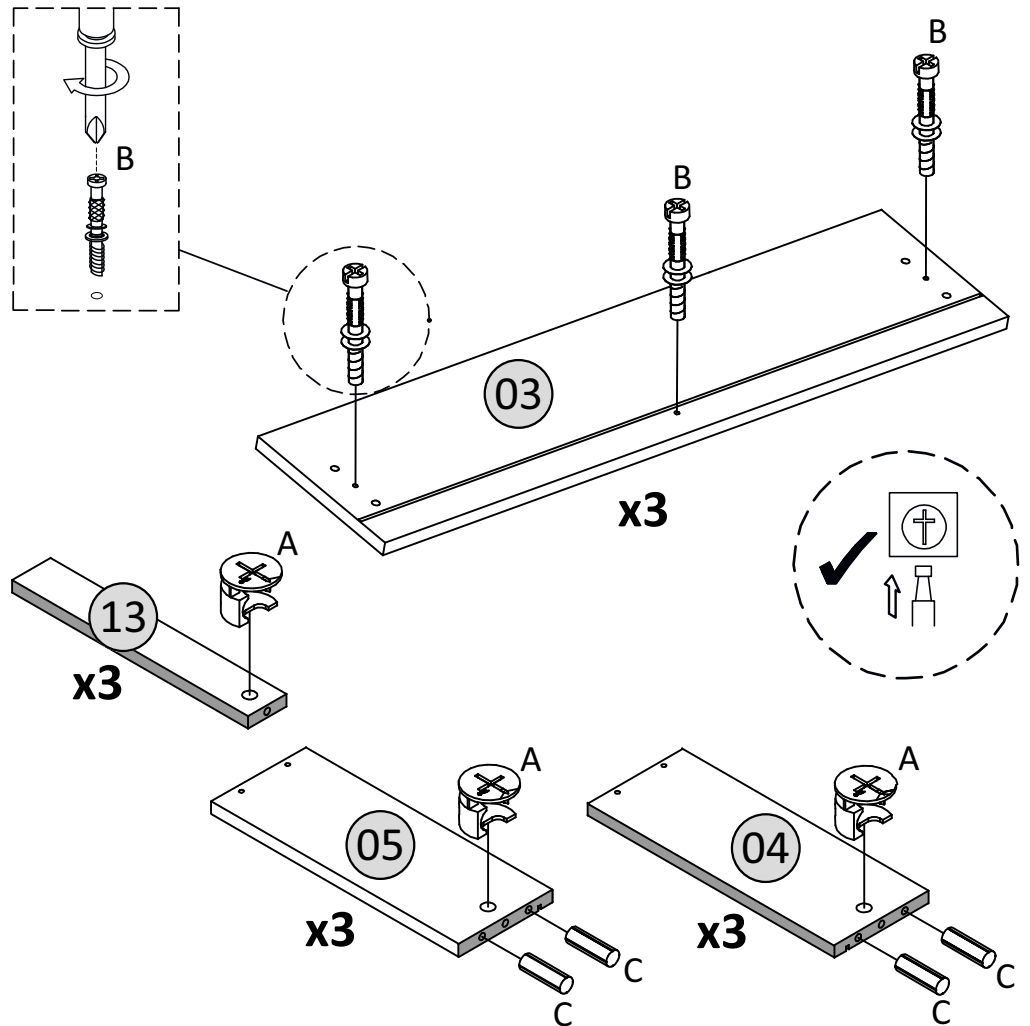
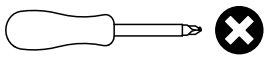

STEP 12

PARTS REQUIRED

- 04 - DRAWER LEFT PANEL x3
- 05 - DRAWER RIGHT PANEL x3
- 10- DRAWER BACK PANEL x3
- 11- DRAWER BOTTOM PANEL x3
- 13- DRAWER SUPPORT PANEL x3

HARDWARE REQUIRED

- D  15

TOOLS REQUIRED

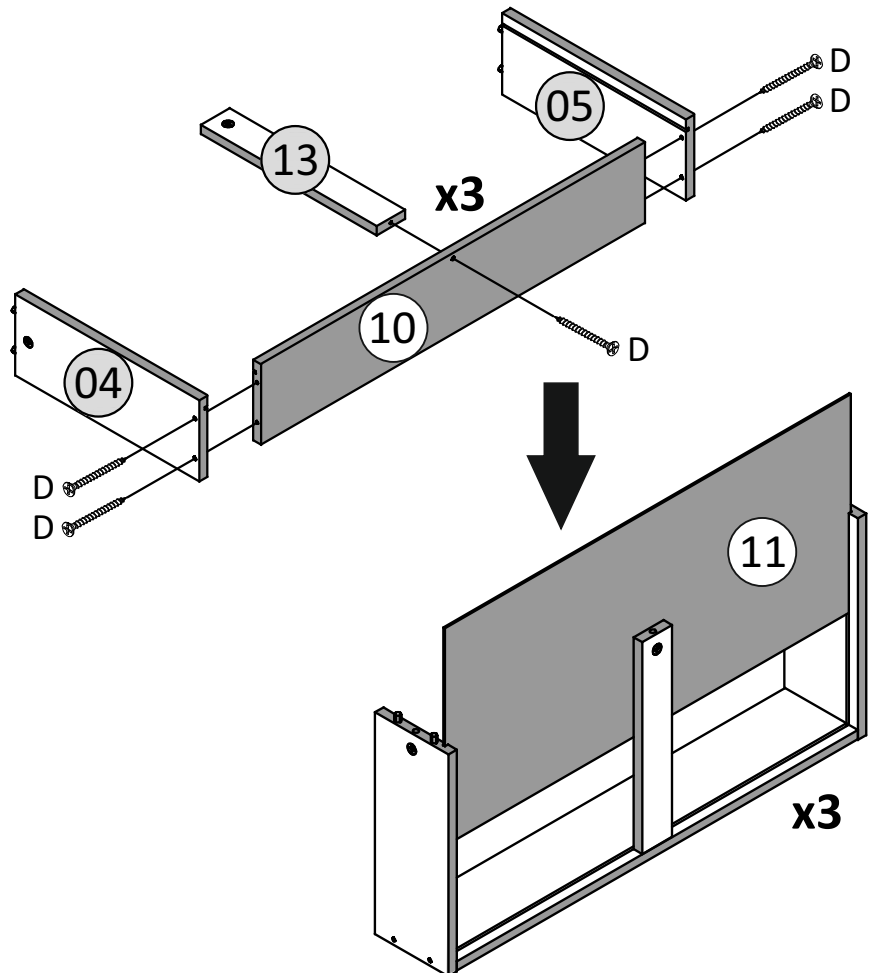
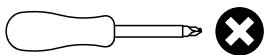

STEP 13

PARTS REQUIRED

03 - DRAWER FRONT x1

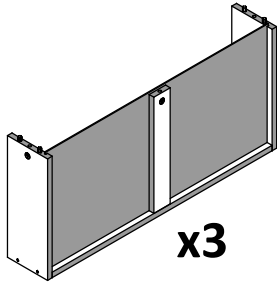

HARDWARE REQUIRED

E  12

F  03

TOOLS REQUIRED

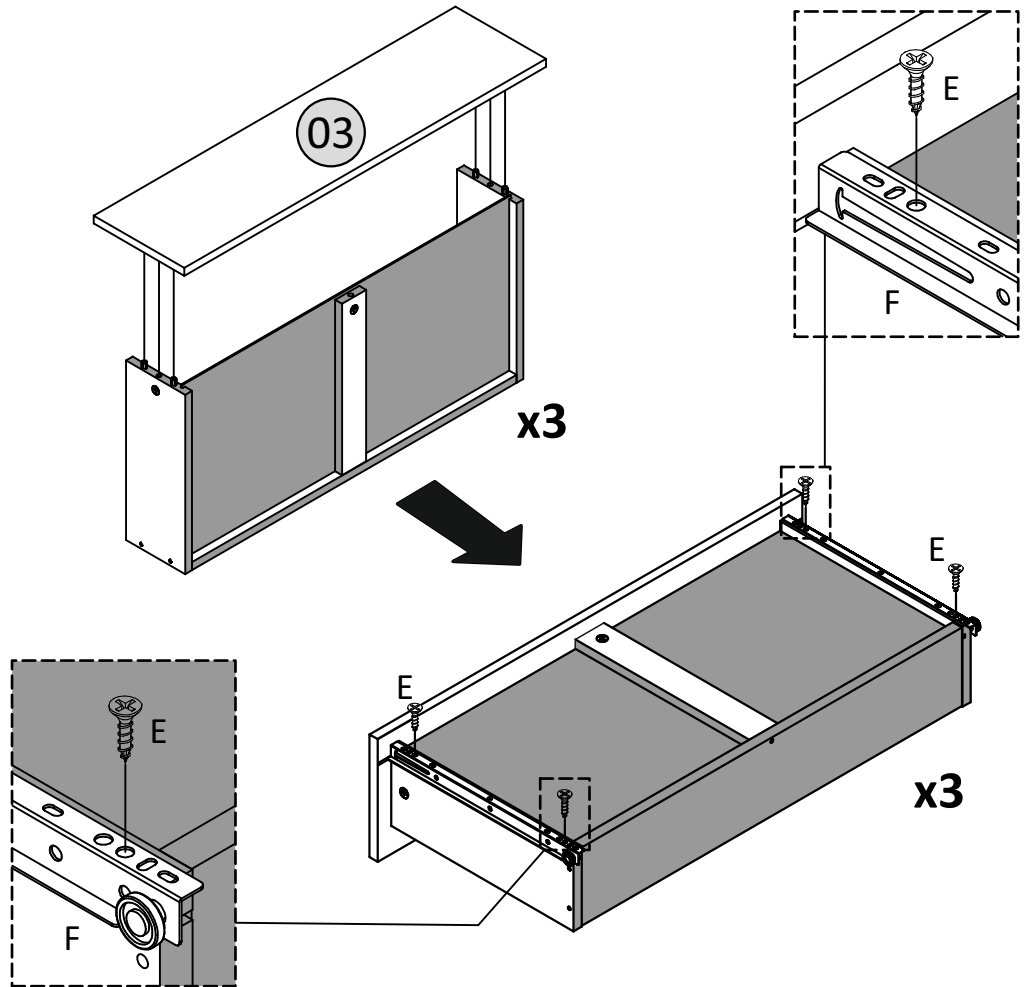
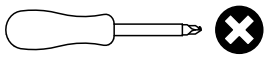

STEP 14

PARTS REQUIRED

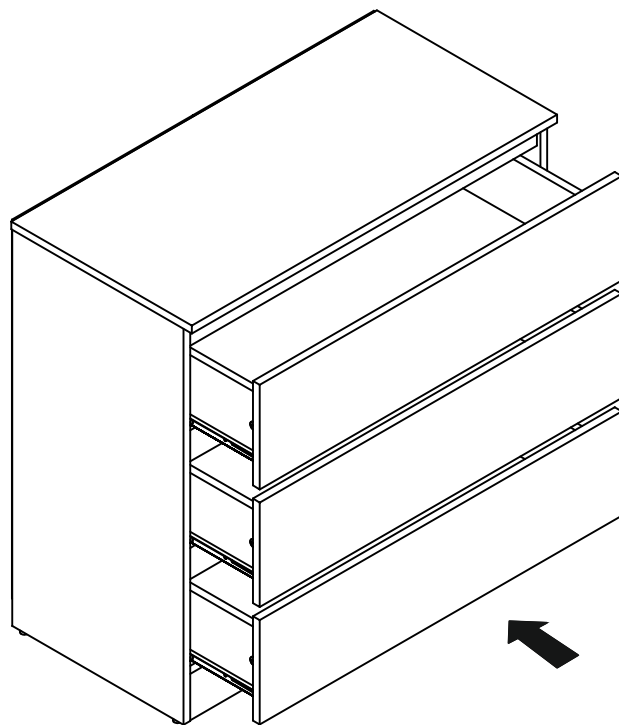
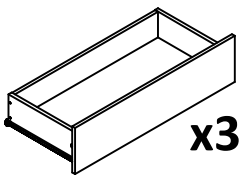
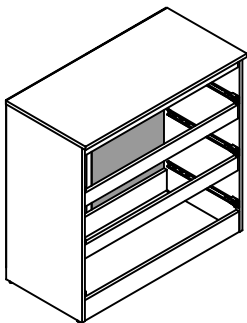

STEP 15

PARTS REQUIRED

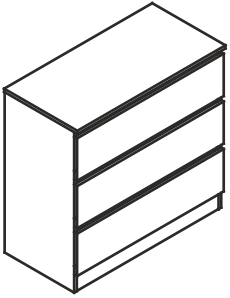

HARDWARE REQUIRED

K		01
---	---	----

TOOLS REQUIRED

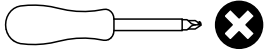

WARNING

Serious or fatal injuries can occur from furniture tipping over. To prevent the furniture from tipping over we recommend that it is permanently fixed to the wall.

Wall fixings are not supplied with this product as different wall materials require different types of fixing devices. Please make sure you use fixings suitable for the walls in your home.

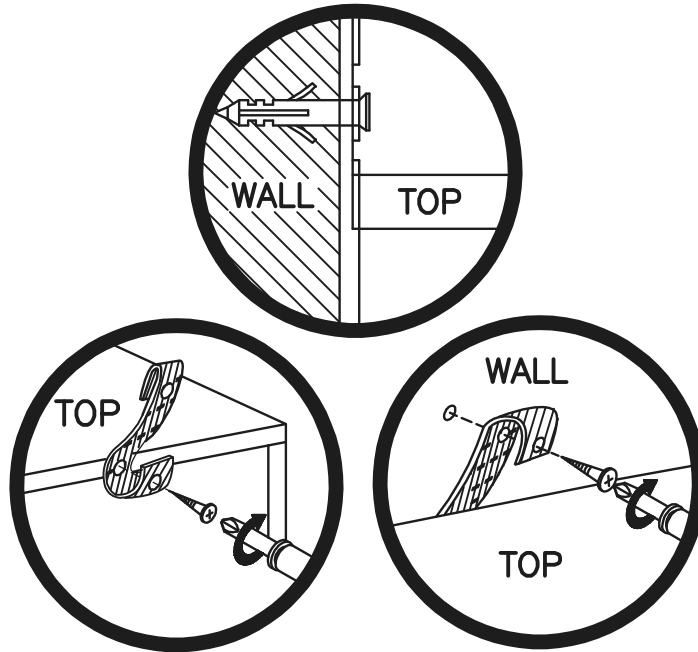

STEP 16

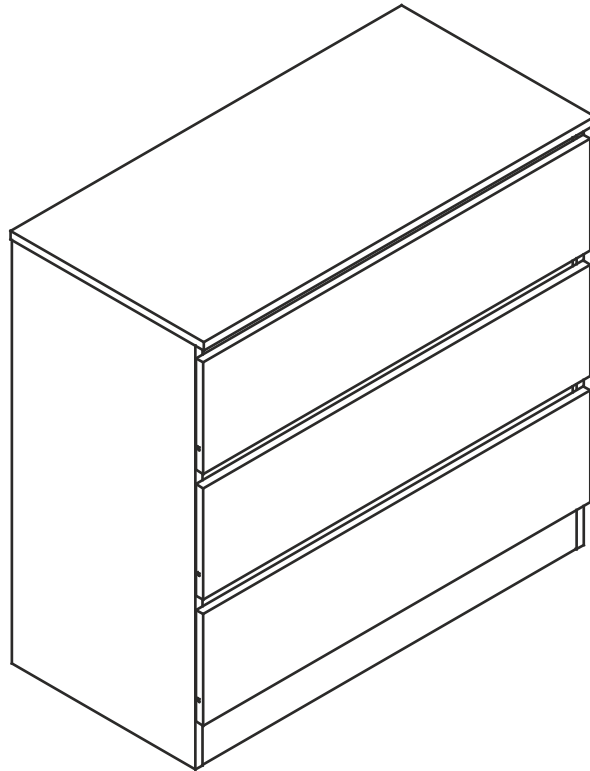

FINISH