

# WINDSOR EXTENDING DINING TABLE ASSEMBLY INSTRUCTIONS

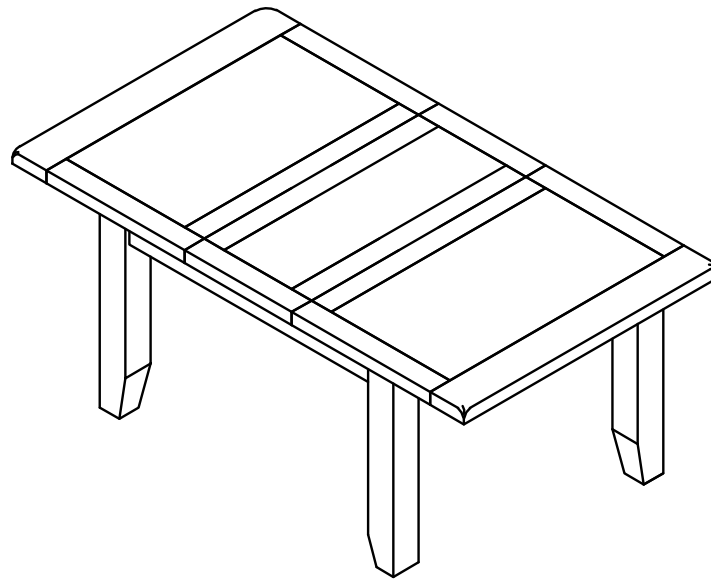

**FOR DOMESTIC USE ONLY  
IMPORTANT  
PLEASE READ BEFORE YOU CONTINUE FURTHER  
CARE AND MAINTENANCE**

**Regular Cleaning:** Dusting: Use a soft, lint-free cloth or a microfibre duster to remove dust regularly. This will prevent the buildup of dirt, which can scratch the surface of the wood. Cleaning: For deeper cleaning, dampen a cloth with water (not wet) and gently wipe the surface. Avoid using harsh chemical cleaners. Instead, opt for mild soapy water or a wood-specific cleaner. Immediately dry the surface with a clean, dry cloth.

**Polishing: (Oak parts only)** Polish Oak Furniture Periodically: To preserve its shine and protect the wood, polish your oak furniture every 3-6 months. Use a high-quality furniture polish or wax designed for oak to enhance its natural beauty. Avoid Silicone-Based Products: Silicone-based polishes can build up over time and damage the finish. Stick to natural waxes or oils specifically made for wood care.

**Protecting the Surface:** Avoid Direct Sunlight: Prolonged exposure to direct sunlight can cause fading or discolouration of the wood. Position furniture away from windows or use UV-blocking curtains to protect the finish. Use Coasters and Mats: Prevent water rings, heat marks, or scratches by using coasters under glasses and mats under hot dishes or cookware.

**Avoid Sharp Objects:** Be mindful of sharp objects, such as knives or keys, which can easily scratch the surface of the wood.

**Humidity and Temperature:** Maintain a Stable Environment:

Your new piece of furniture is sensitive to extreme humidity and dryness. Aim to maintain a stable environment with moderate humidity (around 40-55%) to prevent warping, cracking, or expansion of the wood. Avoid Heat Sources: Keep oak furniture away from heat sources like radiators, fireplaces, or direct exposure to air conditioning, as rapid temperature changes can affect the wood's integrity.

**Dealing with Spills and Stains:** Immediate Cleanup: Always wipe up spills immediately using a clean, dry cloth to avoid liquids soaking into the wood. Persistent Stains: For sticky stains or spills that require deeper cleaning, use a damp cloth with mild soap and dry the area thoroughly afterward. Stubborn Stains: For tougher stains, use a specialized wood cleaner or consult a professional to avoid damaging the surface.

**Periodic Maintenance:** Inspect Regularly: Check the joints, hardware, and overall structure of your furniture regularly. Tighten any loose screws or joints to maintain the stability of the piece. Reapply Protective Finish: Depending on the use, reapply a protective finish, such as oil, varnish, or wax, every few years to maintain the wood's appearance and durability.

**Long-Term Care:** Rotate or Rearrange Items: To prevent uneven wear or discolouration, periodically rotate or rearrange items on your furniture, particularly those that are regularly in the same spot. Use Felt Pads: Attach felt pads to the legs of furniture to prevent scratching floors and to protect the furniture base from damage caused by friction.

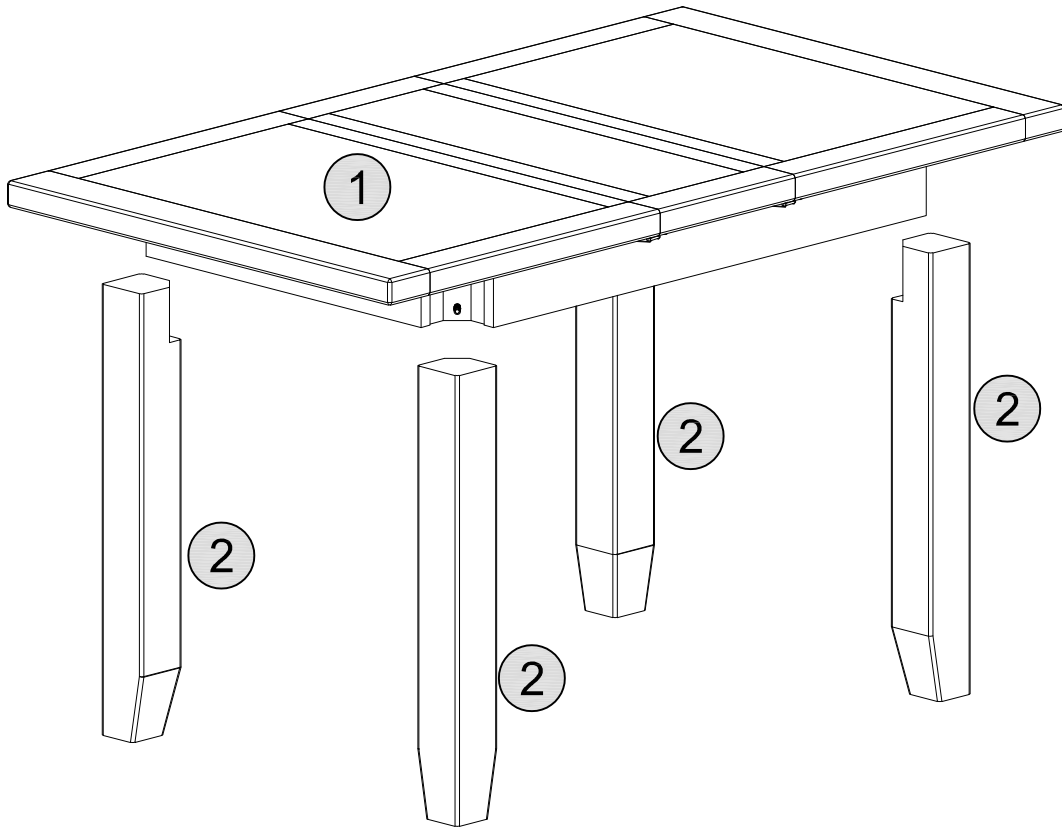



**PLEASE CHECK THAT YOU HAVE ALL THE PARTS LISTED BEFORE YOU START ASSEMBLING. IF YOU DO FIND THAT SOMETHING IS MISSING. DO NOT CONTINUE ASSEMBLY. PLEASE CONTACT YOUR SUPPLIER IMMEDIATELY.**

**PARTS LIST**

<u>Part Number</u>	<u>Part Description</u>	<u>Quantity</u>	<u>Carton</u>
1	Table Top	1	1/2
2	Legs	4	2/2

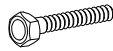
## HARDWARE LIST

REF		HARDWARE NAME	QTY
A		Bolts M10x50	8PCS
B		Washers M10/M23	8PCS
C		Wrench 17mm	1PC

**PLEASE CHECK THAT YOU HAVE ALL THE PARTS LISTED BEFORE YOU START ASSEMBLING. IF YOU DO FIND THAT SOMETHING IS MISSING, DO NOT CONTINUE ASSEMBLY. PLEASE CONTACT YOUR SUPPLIER IMMEDIATELY.**

## TOOLS REQUIRED

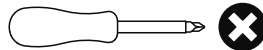

2,5m x 3m

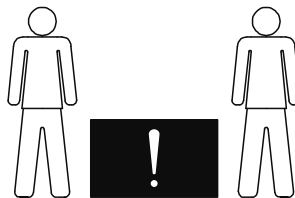
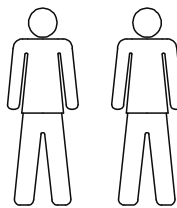
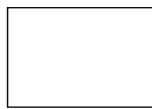

# STEP 1

## PARTS REQUIRED

1 - TABLE TOP x1

2 - LEGS x4



## HARDWARE REQUIRED

A  8

B  8

## TOOLS REQUIRED

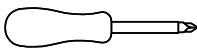
 Wrench 17mm

 

Transit fixing to be unscrewed.  
Unscrew middle screw holding  
fixing to underside of top at each  
end of table.

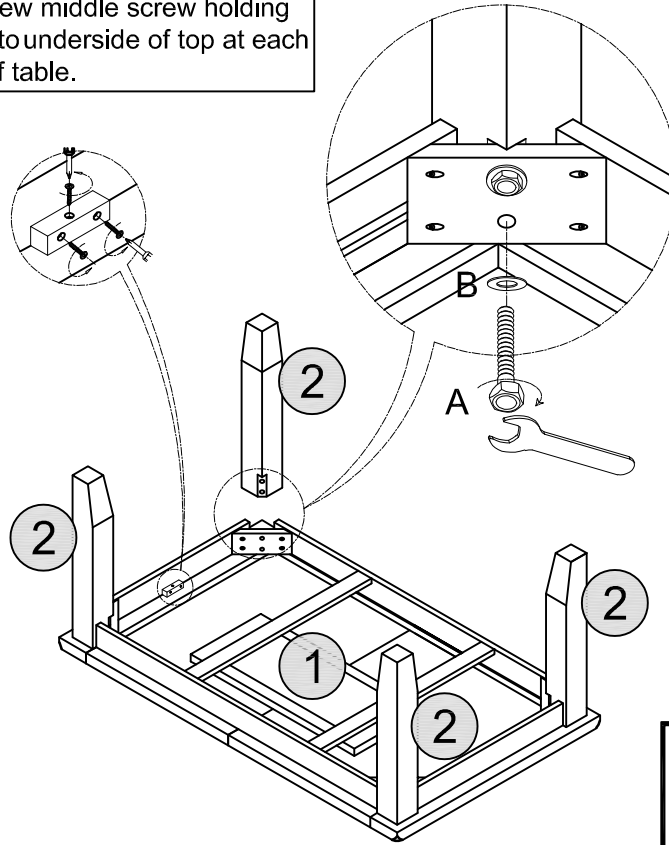

# STEP 2

NOTE: Please check the number on 3  
pieces of the table, all must be the same.

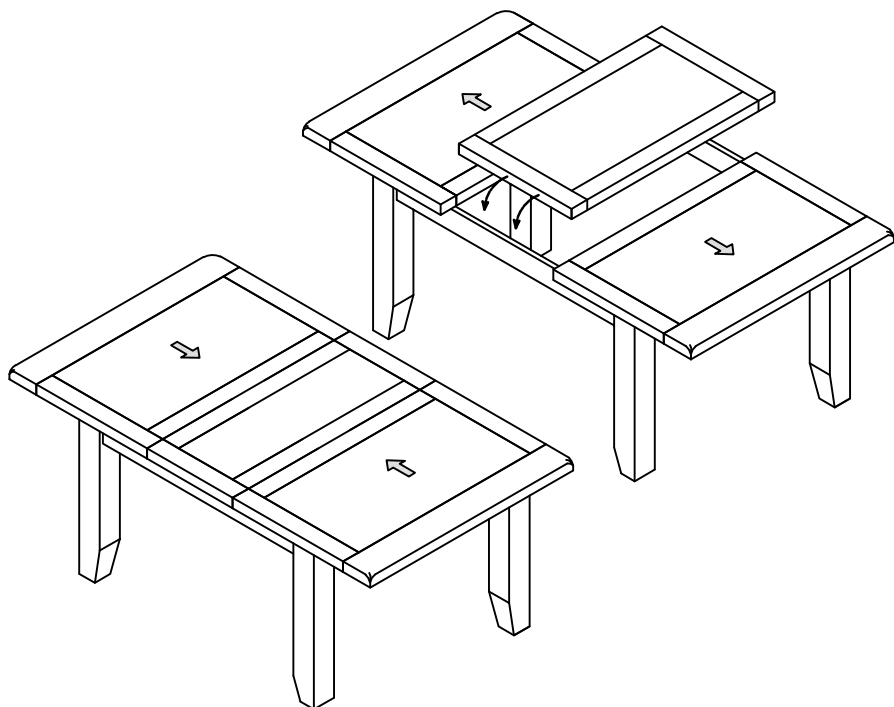

Do not drag or push assembled table  
as this can cause damage to the legs

INFORMATIONS IMPORTANTES (FRENCH)	INFORMACIÓN IMPORTANTE (SPANISH)
<p style="text-align: center;"><b>IMPORTANTE POUR USAGE DOMESTIQUE UNIQUEMENT VEUILLEZ LIRE AVANT DE CONTINUER</b></p> <p>Le produit que vous avez acheté vous offrira de nombreuses années de service si vous suivez les directives pour son assemblage sûr et son entretien et nettoyage périodiques. Montez sur une surface douce et propre. N'utilisez aucun autre outil que ceux indiqués. Les clés ou clés Allen nécessaires sont fournies avec le kit de fixation. En fonction de la fréquence d'utilisation de ce produit, il peut être nécessaire de resserrer les fixations de temps en temps. Cela est tout à fait normal pour tout meuble en kit. Ce produit comprend du verre trempé d'une épaisseur nominale de 8 mm. Si le verre est ébréché ou cassé, remplacez-le par le type décrit ou consultez les détaillants en indiquant les détails du modèle. <b>AVERTISSEMENT</b> La charge maximale sur le dessus ne doit pas dépasser la limite de poids indiquée sur la première page. Ne vous asseyez pas ou ne vous tenez pas debout sur les surfaces en verre. N'utilisez pas le verre comme surface de coupe. Ne frappez pas le verre avec des objets durs ou pointus. Ne placez pas d'objets très chauds ou très froids sur la surface en verre, à moins que des sets de table suffisamment épais ne soient utilisés pour empêcher ces objets d'entrer en contact avec le verre. Pour nettoyer les panneaux en verre, utilisez un chiffon humide ou un cuir avec du liquide vaisselle ou du savon doux si nécessaire. N'utilisez pas de lessive en poudre ou toute autre substance contenant des abrasifs car ceux-ci rayent considérablement le verre. L'utilisation d'outils électriques pour assembler ce produit invalidera toute réclamation et peut endommager ce produit, le rendant dangereux. Conservez ces instructions dans un endroit sûr pour référence ultérieure.</p>	<p style="text-align: center;"><b>IMPORTANTE SOLO PARA USO DOMÉSTICO LEER ANTES DE CONTINUAR</b></p> <p>El producto que ha adquirido le brindará muchos años de servicio si sigue las pautas para su montaje seguro y su mantenimiento y limpieza periódicos. Ensamble sobre una superficie suave y limpia. No utilice herramientas distintas a las que se muestran. Las llaves inglesas o llaves Allen necesarias se incluyen con el kit de accesorios. Dependiendo de la cantidad de uso que reciba este producto, puede ser necesario apretar las fijaciones de vez en cuando. Esto es completamente normal en cualquier mueble de paquete plano. Este producto incluye vidrio templado con un espesor nominal de 8 mm. Si el vidrio está astillado o roto, reemplácelo con el tipo descrito o, alternativamente, consulte con los minoristas indicando los detalles del modelo. <b>ADVERTENCIA</b> La carga máxima en la parte superior no excede el límite de peso que se muestra en la página principal. No se siente ni se pare sobre superficies de vidrio. No use el vidrio como superficie para cortar. No golpee el vidrio con elementos duros o puntiagudos. No coloque elementos muy calientes o muy fríos sobre la superficie de vidrio a menos que se utilicen manteles individuales lo suficientemente gruesos para evitar que dichos elementos entren en contacto con el vidrio. Para limpiar los paneles de vidrio, utilice un paño húmedo o un paño de cuero con detergente líquido o jabón suave, si es necesario. No utilice detergente en polvo ni ninguna otra sustancia que contenga abrasivos, ya que rayan considerablemente el vidrio. El uso de herramientas eléctricas para ensamblar este producto invalidará cualquier reclamo y puede dañar este producto, haciéndolo inseguro. Guarde estas instrucciones en un lugar seguro para futuras consultas.</p>
<p style="text-align: center;"><b>WICHTIGE INFORMATIONEN (GERMAN)</b></p>	<p style="text-align: center;"><b>INFORMAZIONI IMPORTANTI (ITALIAN)</b></p>
<p style="text-align: center;"><b>WICHTIGNUR FÜR DEN HAUSHALTSGEBRAUCH BITTE LESEN SIE, BEVOR SIE FORTFAHREN</b></p> <p>Das von Ihnen erworbene Produkt wird Ihnen viele Jahre lang gute Dienste leisten, wenn Sie die Richtlinien für eine sichere Montage und regelmäßige Wartung und Reinigung befolgen. Auf einer weichen, sauberen Oberfläche montieren. Verwenden Sie keine anderen Werkzeuge als die abgebildeten. Alle benötigten Schraubenschlüssel oder Inbusschlüssel sind im Montagesatz enthalten. Je nach Nutzungsintensität dieses Produkts kann es erforderlich sein, die Befestigungen von Zeit zu Zeit festzuziehen. Dies ist bei Möbeln aus dem Bausatz völlig normal. Dieses Produkt enthält gehärtetes Glas mit einer Nennstärke von 8 mm. Wenn das Glas angeschlagen oder zerbrochen ist, ersetzen Sie es bitte durch das beschriebene Glas oder wenden Sie sich alternativ an den Händler und geben Sie die Modelldetails an. <b>WARNUNG</b> Die maximale Belastung oben darf die auf der Titelseite angegebene Gewichtsgrenze nicht überschreiten. Setzen oder stellen Sie sich nicht auf Glasoberflächen. Verwenden Sie Glas nicht als Schneideunterlage. Schlagen Sie nicht mit harten oder spitzen Gegenständen auf Glas. Stellen Sie keine sehr heißen oder sehr kalten Gegenstände auf die Glasoberfläche, es sei denn, Sie verwenden ausreichend dicke Tischmatten, um zu verhindern, dass diese Gegenstände mit dem Glas in Berührung kommen. Verwenden Sie zum Reinigen von Glasscheiben ein feuchtes Tuch oder Leder mit Spülmittel oder Schmierseife, falls erforderlich. Verwenden Sie kein Waschlaugepulver oder andere scheuernde Substanzen, da diese das Glas stark zerkratzen. Die Verwendung von Elektrowerkzeugen zur Montage dieses Produkts macht jegliche Ansprüche ungültig und kann das Produkt beschädigen, wodurch es unsicher wird. Bewahren Sie diese Anleitung zum späteren Nachschlagen an einem sicheren Ort auf.</p>	<p style="text-align: center;"><b>IMPORTANTE, SOLO PER USO DOMESTICO SI PREGA DI LEGGERE PRIMA DI CONTINUARE OLTRE</b></p> <p>Il prodotto che hai acquistato ti garantirà molti anni di servizio se seguirai le linee guida per il suo montaggio sicuro e la manutenzione e pulizia periodiche. Montare su una superficie morbida e pulita. Non utilizzare utensili diversi da quelli mostrati. Tutte le chiavi inglesi o le chiavi a brugola necessarie sono incluse nel kit di accessori. A seconda della quantità di utilizzo di questo prodotto, potrebbe essere necessario stringere i fissaggi di tanto in tanto. Ciò è del tutto normale per qualsiasi mobile in kit. Questo prodotto include vetro temperato con uno spessore nominale di 8 mm. Se il vetro è scheggiato o rotto, sostituirlo con il tipo descritto o in alternativa consultare i rivenditori indicando i dettagli del modello. <b>AVVERTENZA</b> Il carico massimo sulla parte superiore non deve superare il limite di peso indicato sulla prima pagina. Non sedersi o stare in piedi sulle superfici in vetro. Non utilizzare il vetro come superficie di taglio. Non colpire il vetro con oggetti duri o appuntiti. Non posizionare oggetti molto caldi o molto freddi sulla superficie in vetro a meno che non vengano utilizzati tovagliette adeguatamente spesse per evitare che tali oggetti entrino in contatto con il vetro. Per la pulizia dei pannelli in vetro, utilizzare un panno umido o pelle con detersivo per piatti o sapone delicato, se necessario. Non utilizzare detersivo in polvere o altre sostanze contenenti abrasivi, poiché graffiano notevolmente il vetro. L'uso di utensili elettrici per assemblare questo prodotto invaliderà qualsiasi reclamo e potrebbe danneggiare il prodotto rendendolo non sicuro. Conservare queste istruzioni in un luogo sicuro per riferimento futuro.</p>