

REINFORCED WORKBENCH WITH PEGBOARD

Product Instructions

Product No. 3500156.1

vonhaus

Let's get started!

Visit our product hub for useful tips and tricks on getting the most out of your new product.

SCAN ME



Components

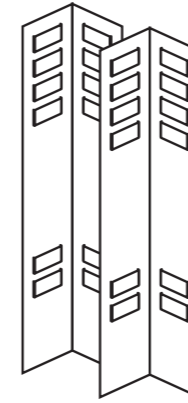

A Front Legs (x2)

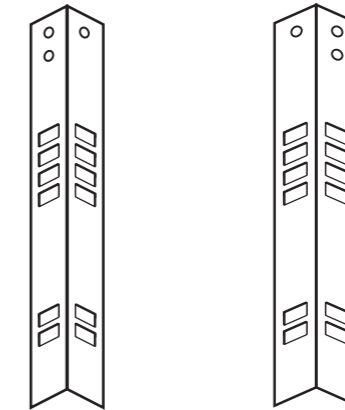

B Back Left Leg (x1) **C** Back Right Leg (x1)

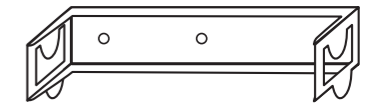

D Left Drawer Support (x1)

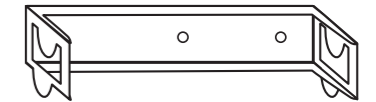

E Right Drawer Support (x1)

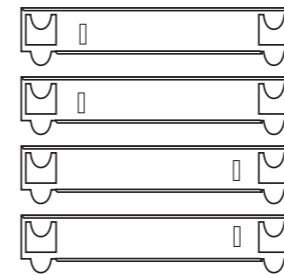

F Short Worktop Supports (x4)

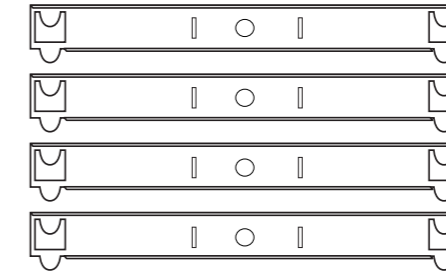

G Long Worktop Supports (x4)

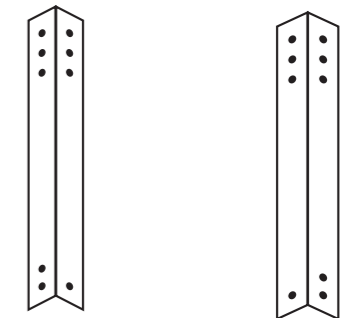

H Left Vertical Support (x1) **I** Right Vertical Support (x1)



J1 Back Support (x1)

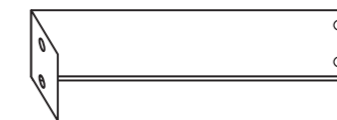

K Left Top Shelf Support (Left) (x1)

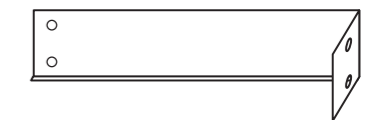

L Right Top Shelf Support (Right) (x1)



J2 Front Support (x1)



M Drawer Front (x2)

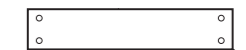

N Drawer Back (x2)

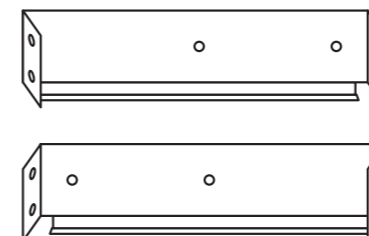

O Drawer Sides (Short) (x4)

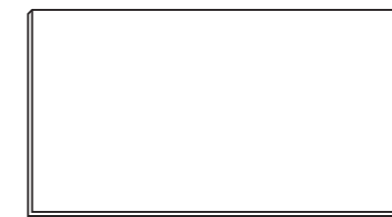

P Drawer Base (x2)

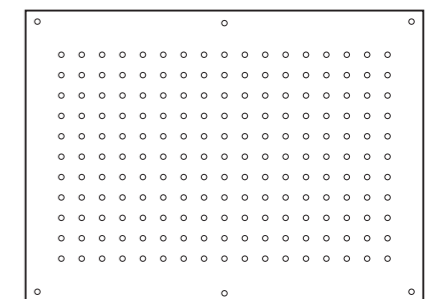

Q Peg Board (x1)



40 Mins

Need further help?
support@vonhaus.com

See our full range at
www.vonhaus.com

Components

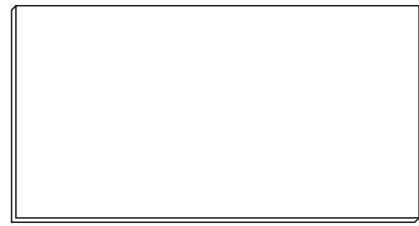

R Bottom Shelf (x1)

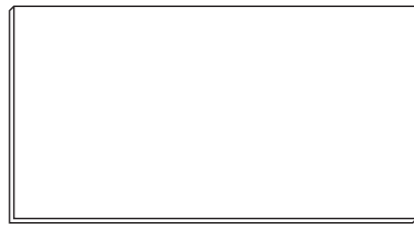

S Worktop (x1)



S1 Drawer Handles (x2)



S2 Pegs (x20)



S3 Cap Feet (x4)

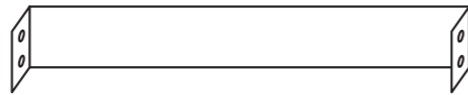

s4 Drawer Support (x1)



s5 Support Bars (x2)



s6 Support Bars (x4)

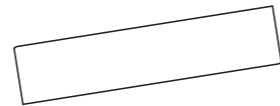

T Top Shelf (x1)

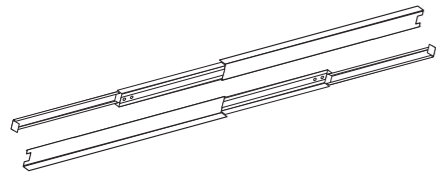

U Drawer Runners (x4)

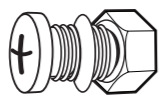

V Short Fixings (x40)

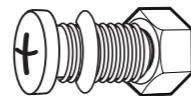

W Long Fixings (x5)



X Nuts/Bolts (Small) (x24)



Y Pegboard Support (x1)

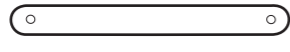

Z (x2)

Tools Required (Not Supplied)

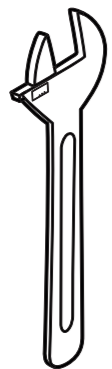

Adjustable



Screwdrivers

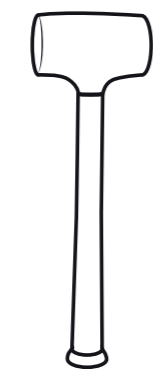

Rubber Mallet

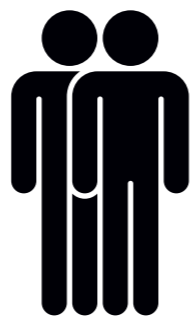

Two person assembly

Assembly

NOTE: In order to allow room for the tabs to fit securely, it is recommended that you gently prise the tabs open using a suitable flat head screwdriver (not supplied). Once the tabs have been inserted, gently tap shut using a suitable rubber mallet (not supplied) to secure.

1

Clip the 4 Cap Feet (S3) onto the ends of the Legs (A, B, C) as illustrated.

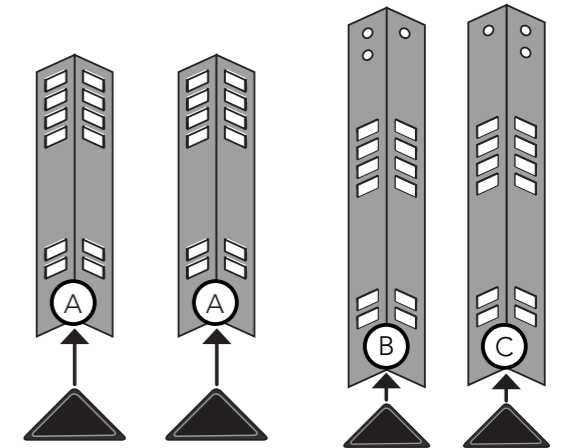

2

Fit the Drawer Supports (D, E) between the Front and Back Legs (A, B, C) and secure as illustrated.

NOTE: The Drawer Supports should be fitted between the 3rd and 4th slots and face outwards.

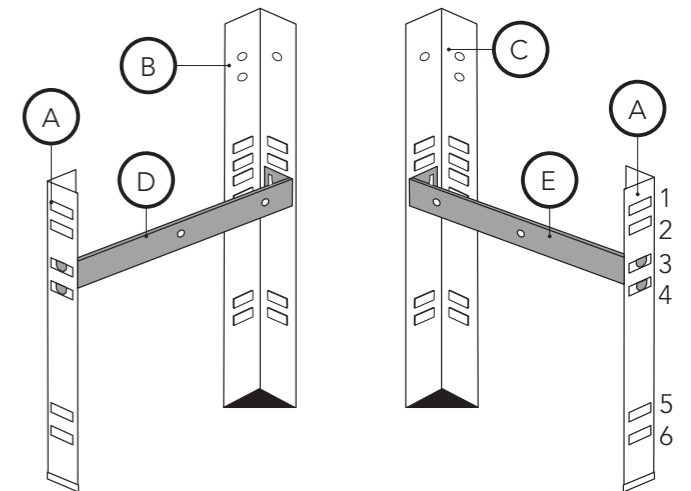

3

Fit the 4 Worktop Supports (F) to the Front and Back Legs (A, B, C) as illustrated.

NOTE: The Short Worktop Supports should be positioned between the 1st/2nd and 5th/6th slots.

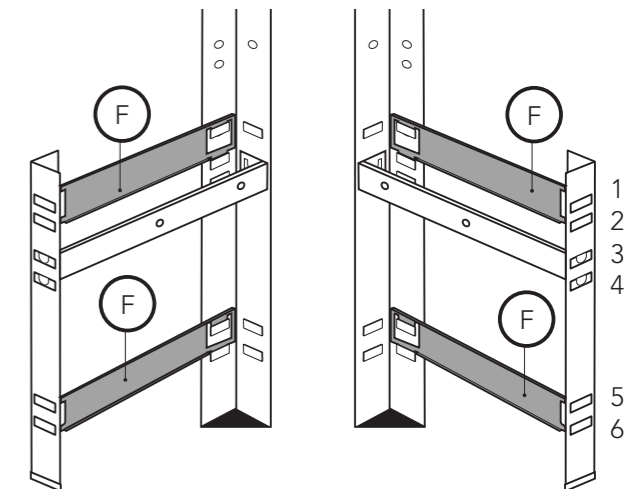

Assembly

4

Fit the 4 Long Worktop Supports (G) to the Front and Back Legs (A, B, C) at the 1st/2nd and 5th/6th slots.

NOTE: The Long Worktop Support with the central hole should be positioned between the 1st/2nd slots on the Back Legs (B, C).

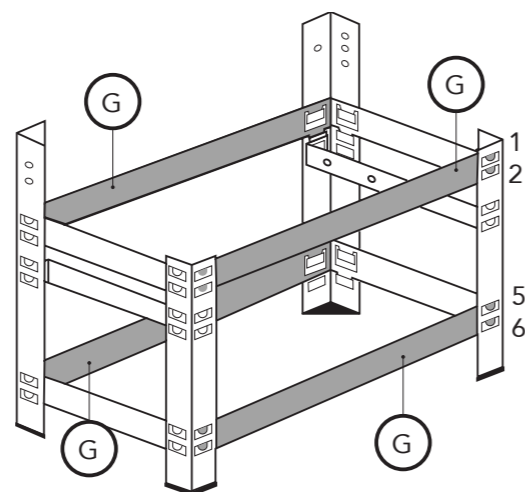

5

Fit the Supports (S5 & S6) to the frame.

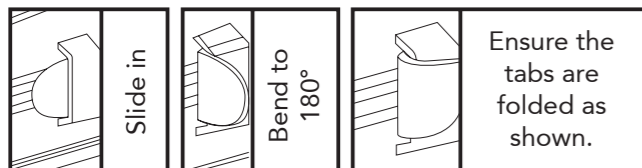
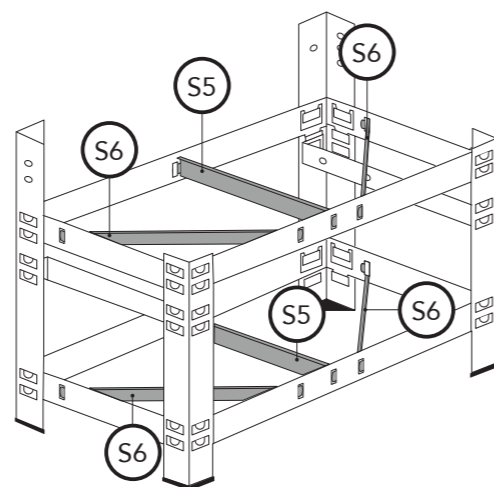

6

Fit the Left and Right Upper Vertical Supports (H, I) into the sides of the Back Legs (B, C). Secure using 4 Short Fixings (V).

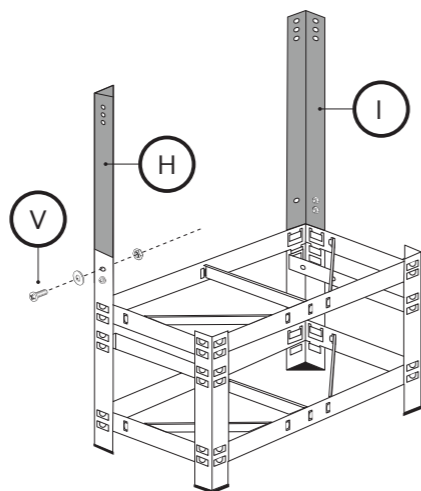

Assembly

7

Fix the Back Support (J1) to the top 2 holes of the Vertical Supports (H, I). Secure using 4 Short Fixings (V). Tighten to secure.

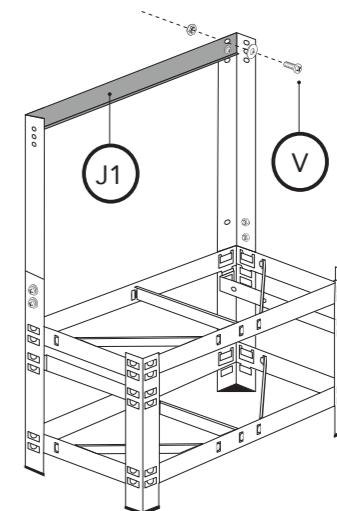

8

Fix the longest edge of the Short Top Shelf Supports (K, L) to the top 2 holes of the Vertical Supports (H, I) using 4 Short Fixings (V) as illustrated. Tighten to secure.

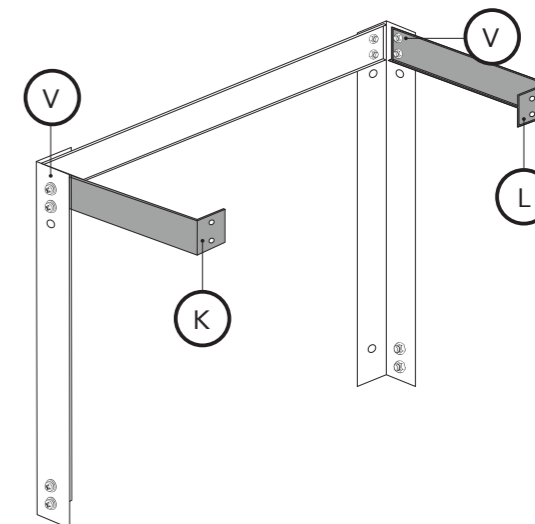

9

Fix the Front Support (J2) to the front of the Short Top Shelf Supports (K, L) using 4 Short Fixings (V) as illustrated. Tighten to secure.

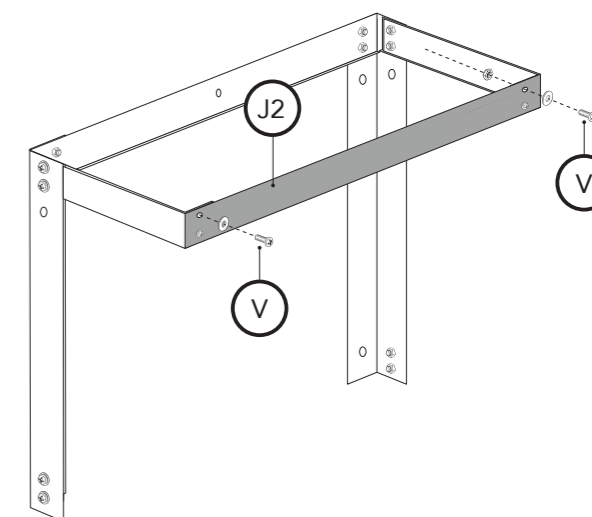

Assembly

10

Fix Peg Board (Q) with 4 Long Fixings (W). Tighten to secure.

Add brackets (Z) to each side and secure with 4 Short Fixings (V)

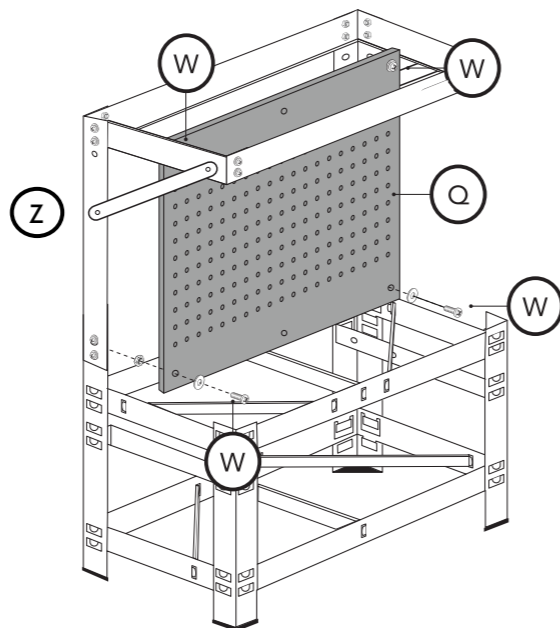

11

Using 2 Short Fixings (V), attach the Pegboard Support (Y) to the rear of the assembly through the vacant holes on the Long Supports (G, J1).

Insert the 2 Long Fixings (W) into the vacant holes on the Pegboard Supports (Y) and into the Pegboard (Q). Tighten all to secure.

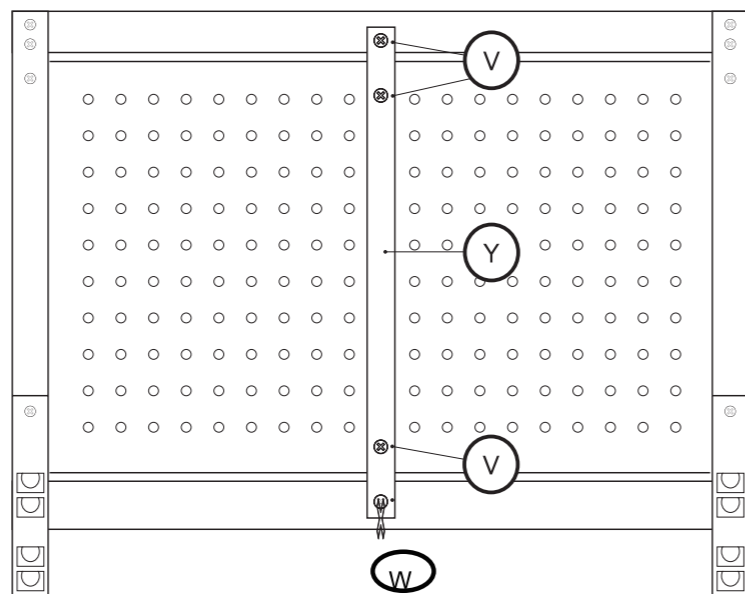

Drawer Assembly

12

Fix the Drawer Handle (S1) to the Drawer Front (M) by inserting 8 Small Nuts/Bolts (X) from the outside in towards the ledge. Tighten to secure.

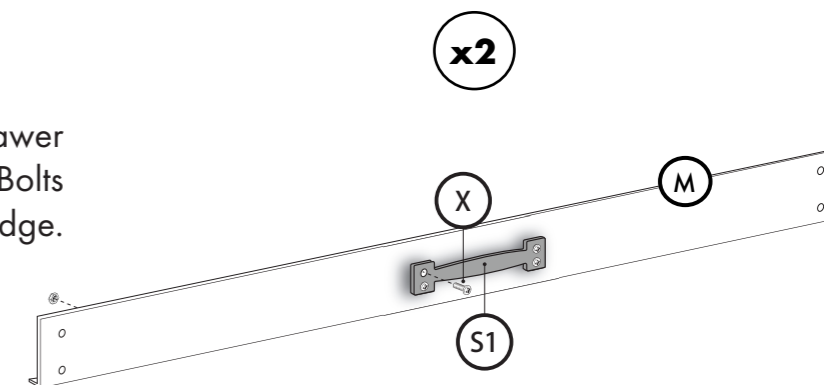

13

Fix the Short Drawer Sides (O) to the Drawer Front (M) using 4 Short Fixings (V). Tighten to secure.

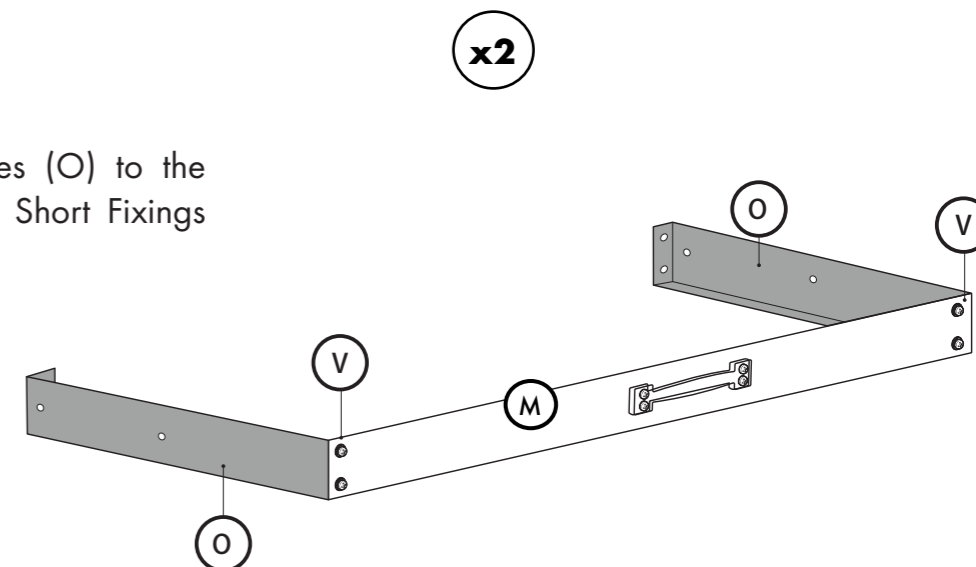

14

Lower the Drawer Base (P) into the Drawer Assembly to rest on the inner ledges.

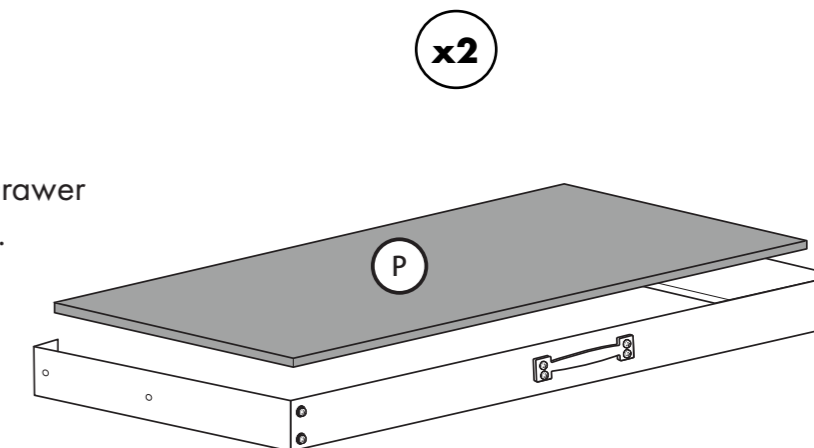

Drawer Assembly

15

Fix the Drawer Back (N) to the assembly and secure using (V).

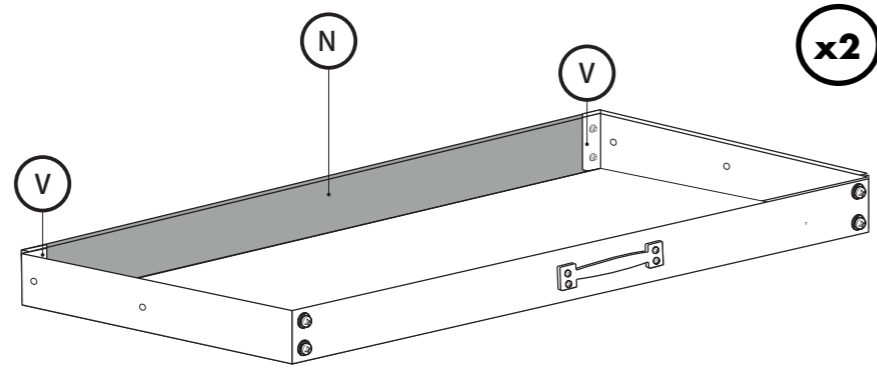

16

Holding the drawer within the Workbench assembly, extend and align the Drawer Runners (U) with the fixing holes in the Drawer Supports (D, E). Insert 4 Small Fixings (X) through the Runners and into the Supports. Tighten to secure.

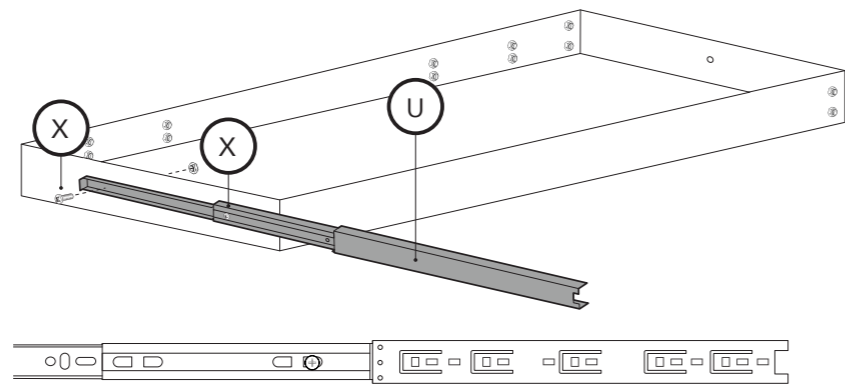

17

Attach the Drawer Support (S4) into the centre of the Drawer assembly. Secure using 4 Short Fixings (V).

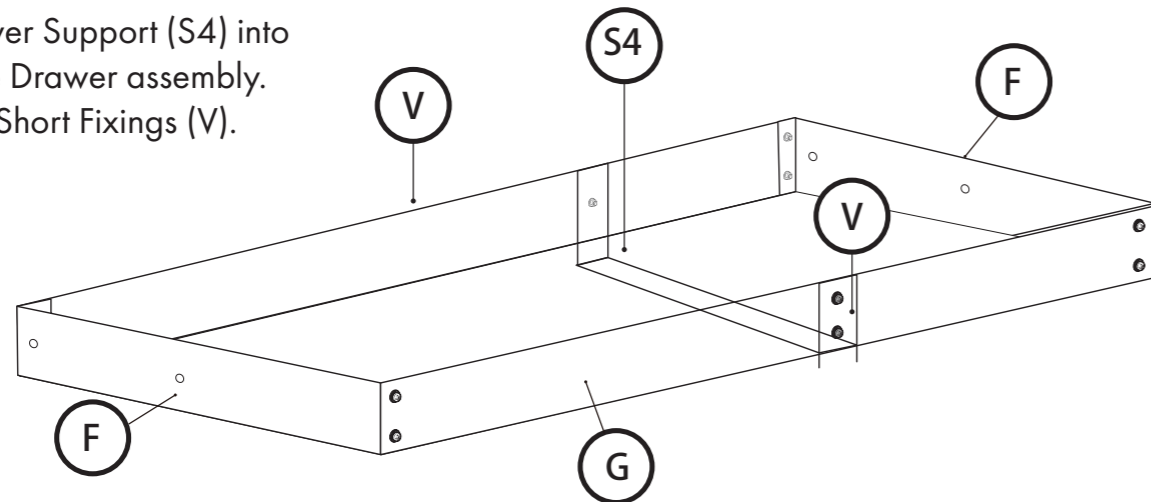

Drawer Assembly

18

Fix the 2 Drawer Runners (U) to the Short Drawer Sides (O) using 4 Small Nuts/Bolts (X) through the available holes as illustrated. Tighten to secure.

Note: Fix D into S4, another drawer repeat it again. Fix E into S4.

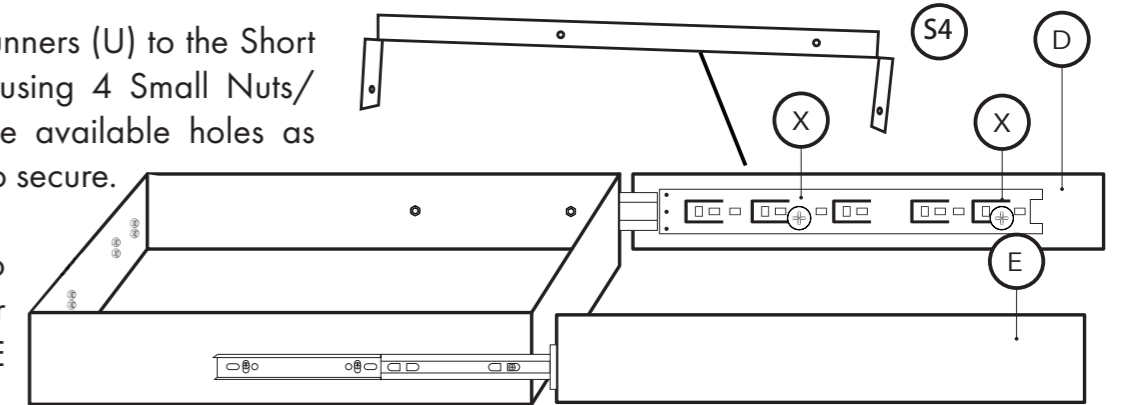

19

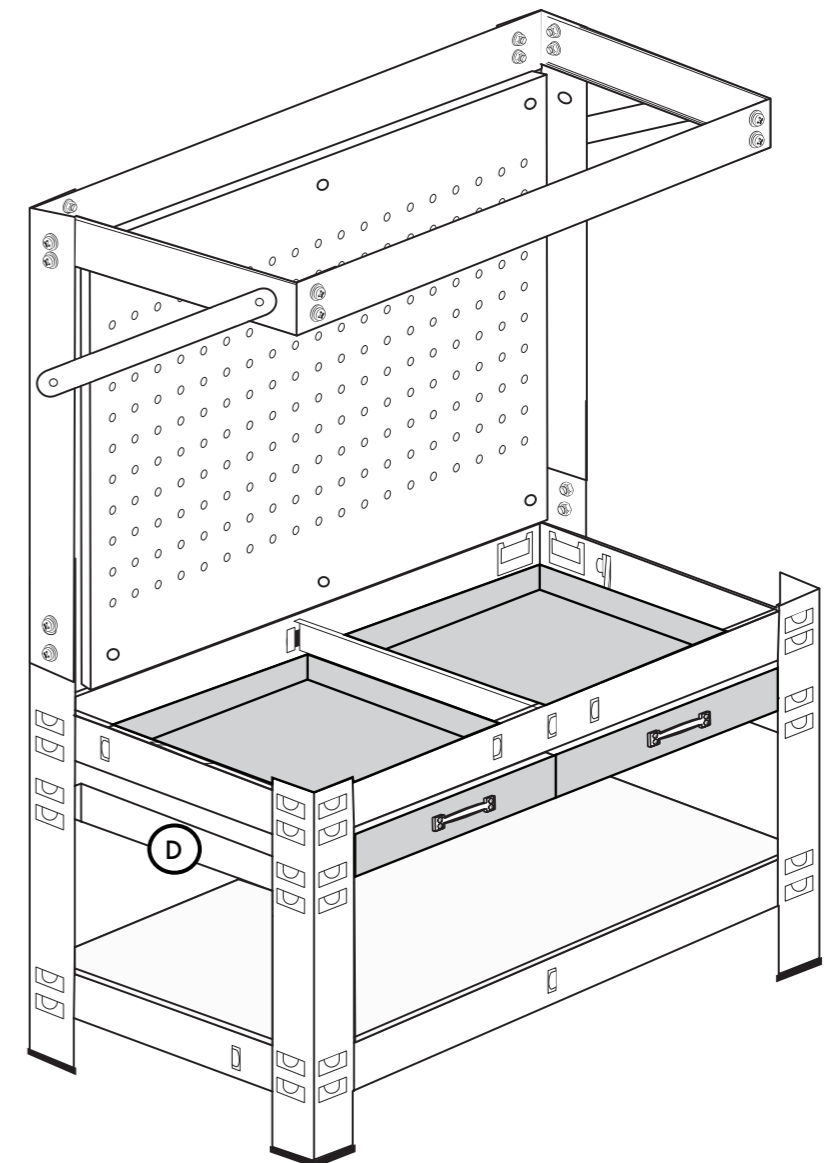

Shelves Assembly

20

ADDITIONAL: Insert Pegs (S2) into the Pegboard (Q) to hang tools for convenience.

CAUTION: Do not overload the Pegs. Always distribute the weight of heavy tools evenly using multiple Pegs or store safely on the shelving.

CAUTION: It is recommended that you store heavy tools on the base of the Workbench. A top heavy assembly can cause serious injury. It is recommended that you source suitable hardware to permanently affix your Workbench to a suitable strong wall.

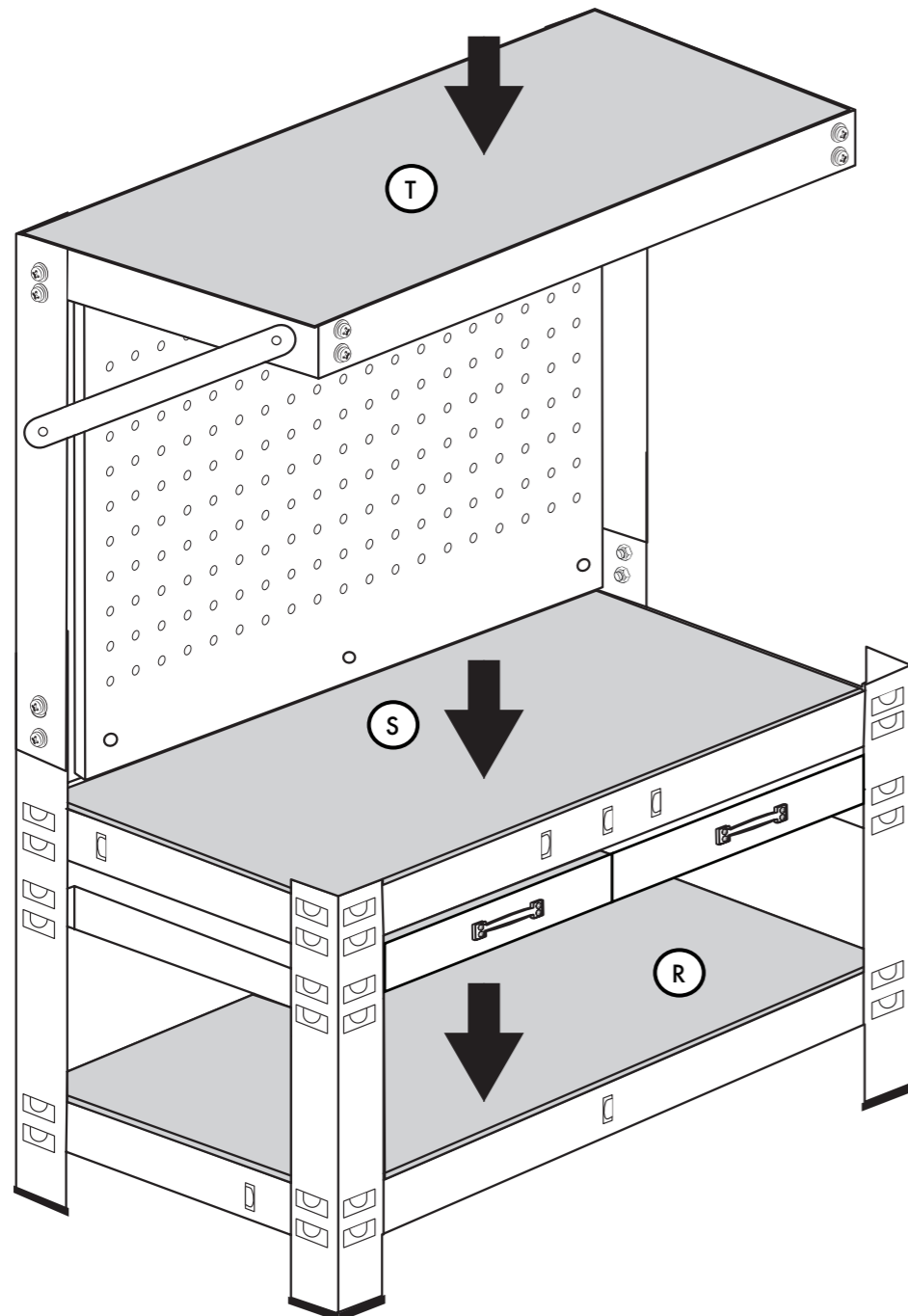

Information

Important Safety Notice

This product is **not suitable for use by children** or by individuals with **physical, sensory, or mental impairments** that may limit their ability to operate the equipment safely, **unless** they have been given supervision or instruction concerning the safe use of the product by a person responsible for their safety.

Improper use may result in serious injury. Always ensure the operator is capable of understanding and following all safety instructions provided in this manual.

Safety Tips

Tighten screws firmly, but avoid over-tightening. Excessive tightening can damage the product and significantly reduce its holding power.

Use only for its intended purpose. Never stand, hang, or climb on the product.

Information

Customer Service

If you are having difficulty using this product and require support, please contact support@vonhaus.com

Warranty

To register your product and find out if you qualify for a free extended warranty please go to www.vonhaus.com/warranty

Please retain a proof of purchase receipt or statement as proof of the purchase date.

The warranty only applies if the product is used solely in the manner indicated in the warnings page of this manual, and all other instructions have been followed accurately.

Any abuse of the product or the manner in which it is used will invalidate the warranty.

Returns

Returned goods will not be accepted unless re-packaged in its original packaging and accompanied by a relevant and completed returns form. This does not affect your statutory rights.

No rights are given under this warranty to a person acquiring the appliance second-hand or for commercial or communal use.

Copyright

All material in this instruction manual are copyrighted by DOMU Brands.

Any unauthorised use may violate worldwide copyright, trademark, and other laws.

Thank You

Thank you for purchasing your product/appliance.

Should you require assistance with your purchase, please contact us at support@vonhaus.com

Vonhaus is a registered trademark of DOMU Brands Ltd.

Made in China for DOMU Brands Ltd.
Unit 30, Stakehill Industrial Estate
Middleton, Manchester, M24 2RW

EU Authorised Representative

Authorised Representative Service
77 Camden Street Lower
Dublin, D02 XE80
Ireland

Let's get started!

Visit our product hub for useful tips and tricks on getting the most out of your new product.

SCAN ME

