

EMtronics

EMAFDD9LWH 9L Double Air Fryer



User Manual

Contents

Introduction	3
General Description	3
Digital Panel Function	3
Important	4
Automatic Switch-Off	6
Before First Use	6
Preparing for Use	7
Using the Appliance	7
Match Cook	8
Smart Finish	8
Pre-Heat/Manual	8
Dehydrate	8
Cooking Timetable	9
Operation Tips	10
Using Oil	10
Food Tips	10
Reheating Foods	10
Cooking Guide	11
Making home-made fries	13
Cleaning	14
Storage	14
Troubleshooting	15
Technical Data	17
Disposal	17
Help Line	17

Introduction

Thank you for buying this top-quality air fryer. You will now be able to cook a wide assortment of food in a healthier manner – with little or no oil!

The air fryer uses hot air, in combination with high-speed air circulation, and a top grill to prepare your dishes quickly and easily. The ingredients are heated from all sides, at once, and there is no need to add oil in most cases.

General Description

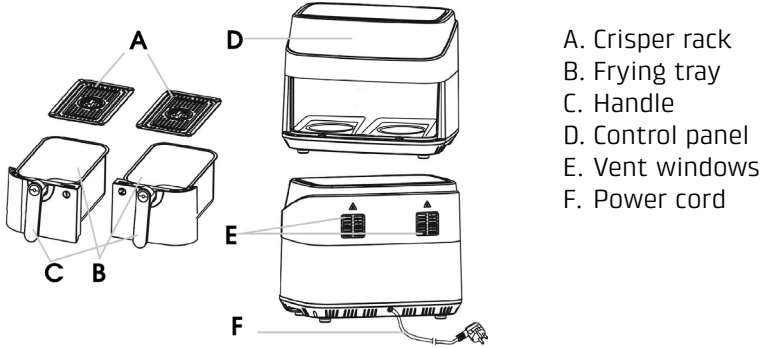

- A. Crisper rack
- B. Frying tray
- C. Handle
- D. Control panel
- E. Vent windows
- F. Power cord

Digital Panel Function

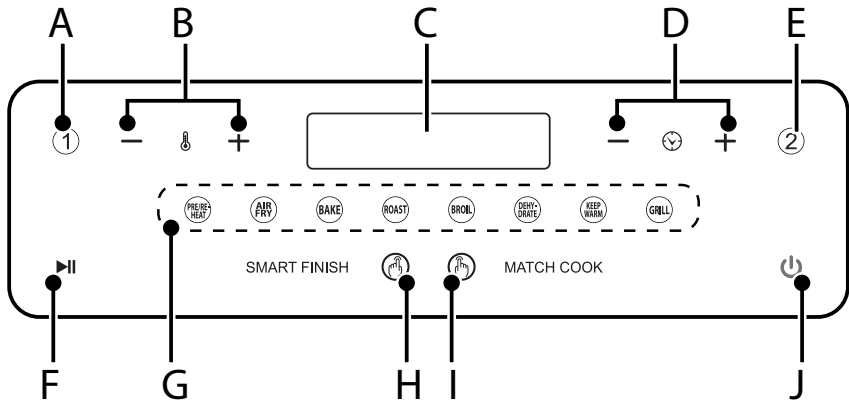

- A. Zone 1
- B. Timer / Temperature Display
- C. Temperature Plus / Minus
- D. Timer Plus / Minus
- E. Zone 2
- F. Start / Pause
- G. Pre-Set Mode Selection
- H. Smart Finish
- I. Match Cook
- J. Power

Important

- Read this user manual carefully, before you use the appliance, and keep it safely for future reference.
- **Danger**
- Never immerse the housing, which contains electrical components and the heating elements, in water nor rinse it under the tap.
- Do not let any water or other liquid enter the appliance – to prevent electric shock.
- Always put the ingredients to be fried in the basket, to prevent it from coming into contact with the heating elements.
- Do not cover the air inlet and the air exhaust openings while the appliance is operating.
- Do not fill the frying tray with oil as this may cause a fire hazard.
- Never touch the inside of the appliance while it is operating.
- Check whether the voltage indicated on the appliance corresponds to the local mains voltage in your country before you connect the appliance.
- Do not use the appliance if the plug, the power cord or the appliance itself is damaged.
- If the power cord is damaged, you must have it replaced at a service center authorized by similarly qualified persons in order to avoid a hazard.
- This appliance can be used by children aged from 8 years and above and persons with reduced physical, sensory or mental capabilities or lack of experience and knowledge if they have been given supervision or instruction concerning use of the appliance in a safe way and understand the hazards involved. Children shall not play with the appliance. Cleaning and user maintenance shall not be made by children without supervision.

- Keep the appliance and its mains cord out of the reach of children when the appliance is switched on or is cooling down.
- Keep the mains cord away from hot surfaces.
- Do not plug in the appliance or operate the control panel with wet hands.
- Only connect the appliance to an earthed wall socket. Always make sure that the plug is inserted into the wall socket properly.
- Never connect this appliance to an external timer switch.
- Do not place the appliance on or near combustible materials such as a tablecloth or curtains.
- Do not place the appliance against a wall or against other appliances. Leave at least 10cm free space at the back and sides and 10cm free space above the appliance. Do not place anything on top of the appliance.
- Do not use the appliance for any purpose other than described in this manual.
- Do not let the appliance operate unattended.
- During hot air frying, hot steam is released through the air exhaust openings. Keep your hands and face at a safe distance from the steam and from the air exhaust openings. Also be careful of hot steam and hot air when you remove the frying tray from the appliance.
- The surface below the appliance may become hot during use.
- Immediately unplug the appliance if you see dark smoke coming out of the appliance. Wait for the smoke emission to stop before you remove the frying tray from the appliance.

• Caution

- Place the appliance on a horizontal, level and stable surface.
- This appliance is intended for normal household use only. It is not intended for use in environments such as staff kitchens, offices, farms or other work environments. Nor is it intended to be used by clients in hotels or other similar environments.
- If the appliance is used improperly or if it is not used according to the instructions in the user manual, the warranty becomes invalid and refuses any liability for any damage that may be caused.
- Always unplug the appliance after use.
- Let the appliance cool down for approx. 30 minutes before you handle or clean it.

Automatic Switch-Off

This appliance is equipped with a timer. When the timer has counted down to 0, the appliance produces a BEEP sound and switches off automatically. To switch off the appliance manually, press “Power” to shut down the unit.

Note: Pressing “Start/Pause” only pauses the air frying process, the unit will NOT be switched off.

Before First Use

1. Remove all packing material.
2. Remove any stickers or labels from the appliance – other than the rating label.
3. Thoroughly clean the basket, and frying tray, with warm water and some liquid washing soap using a non-abrasive sponge.
Note: You can also clean these parts in the dishwasher.
4. Wipe the outside of the appliance with a moist cloth.

Note: Do NOT remove the silicone rubber grips at the corners of the crisper racks. These are designed to be left in place while the unit is in use.

Preparing for Use

1. Place the appliance on a stable, horizontal and level surface that is also heat resistant.
2. Place the crisper rack in the frying tray properly.

Do not fill the frying tray with oil or any other liquid.

Do not put anything on top of the appliance. This disrupts the airflow and affects the air-frying result.



Using the Appliance



1. Power on

When plugging the unit into a wall outlet there will be a beep sound and the power button  will illuminate RED.

Now press the power button  and the unit control panel will light up ready for use.

2. Setting zone, cooking time and temperature:

Select the cooking zone (left or right tray) by pressing button 1  (left side) or 2  (right side).

Then press one of the 8 pre-set cooking modes which will input both the time and temperature automatically. At this stage you can freely edit both cooking time and temperature if you wish by using Time -  + and Temperature -  + buttons. Both temperature and cooking time are alternated between constantly on each display to show the current settings.

Note: If the zone buttons (1 or 2) stop flashing, setting mode has timed out (10 seconds max) press zone 1 or 2 again to continue the setting function if needed.

Now if required, select the other cooking zone by pushing button 1 for left tray or 2 for right tray and repeat as above to set for the food being cooked in that zone. If only using one zone (one cooking tray side) this stage can be skipped.

Press the Start/Pause button  to begin the cooking cycle.

When either side reaches a time of "00" a cooling cycle starts for 60 seconds and the display will remain at "00", after which beeps will sound and the display will show "---" indicating the cooking cycle is over.

Match Cook



As an option If you are intending to use both zones (both trays) to cook with identical time and temperature, (usually if cooking the same food type in both sides), simply push the “Match Cook” button instead of the zone 1 ① and 2 ② buttons described in section 2 above. Now any pre-set cooking modes and any edits to time or temperature will be duplicated in both cooking zones (both sides) saving time setting them individually.

Smart Finish

If you are intending to use both zones (both trays) to cook with different cooking times (usually if cooking different food types in each side). Smart Finish will automatically delay the start of the shortest cycle so that both zones finish at the same time.

To use Smart Finish press the “Smart Finish” button first just after switching the unit on, it will flash to show it is active, then proceed to set the zone 1 and zone 2 in the same way as described in section 2 above.

Pre-Heat/Manual

The Pre-Heat button  is simply an extra cooking pre-set mode and can be used in the same way as any of the pre-set modes (food icons) as described in section 2 above. The Pre-Heat pre-set mode sets the time to 3 minutes and the temperature to 180°C. As with the other pre-set modes this can also be edited and used as a Manual setup mode for time and temperature. To Do this, Select the cooking zone (left or right tray) by pressing button 1 ① or 2 ②. Select the Pre-Heat/Manual button , you can now freely edit both cooking time and temperature. Both temperature and cooking time are alternated between constantly on each display to show the current settings.

Dehydrate

Dehydrating food is a preservation method used to extend the shelf-life of your food by removing its water content. It is also one of the oldest and most widespread food preservation techniques.

Dehydrate is one of the 8 preset cooking modes included on this air-fryer and can be selected and carried out by the method shown on the previous page “Using the Appliance”. It can also be set to run in both cooking trays at the same time if required.

Please note: As the temperature for dehydrating is much lower than normal cooking modes it is best not to run the dehydrate mode while cooking at high temperatures in the other compartment as cross overheat can affect the dehydrating action.

Cooking Timetable

Apart from the preset menu, you also can use this air fryer to make other food by setting the time and temperature. This table below helps you to select the basic settings for the ingredients you want to prepare.

Note: Keep in mind that these settings are only for reference. As ingredients differ in origin, size, shape and brand, we cannot guarantee the best setting for your ingredients.

Program Logic					
	Menu	Default		User Selectable Range	
		Time (min)	Temperature °C	Time (min)	Temperature °C
Function	Pre/Re-Heat	15	150°C	1-99	50-200°C
	Air Fry	20	200°C	1-99	50-200°C
	Bake	25	160°C	1-99	50-200°C
	Roast	25	200°C	1-99	50-200°C
	Broil	12	200°C	1-99	50-200°C
	Dehydrate	360	60°C	30-1440	30-80°C
	Keep Warm	30	100°C	1-99	50-200°C
	Grill	20	150°C	1-99	50-200°C

Caution: Do not touch the frying tray during and about 30mins after use, as it gets very hot. Only hold the pan by the handle.

Operation Tips

1. Put the mains plug in an earthed wall socket.
2. Put the frying tray in the right position. Choose function from menu and press START/PAUSE to start cooking.
3. Screen Display
It will show temperature and time. Temperature is the setting temperature and time is remaining working time.
The function we have selected is flicker
4. Some ingredients require shaking halfway through the preparation time (see section 'Settings' in this chapter). To shake the ingredients, pull the frying tray out of the appliance by the handle and shake it. Then slide the frying tray back into the air fryer.
5. When the timer end, pull the frying tray out of the appliance and place it on a heat-resistant surface.
6. Check if the ingredients are cooked well.
7. If the ingredients are not ready yet, simply slide the frying tray back into the appliance and cook it extra minutes
8. Empty the frying tray into a bowl or onto a plate.
9. Tip: To remove large or fragile ingredients, use a pair of tongs to lift the ingredients out of the basket.
10. When a batch of ingredients is ready, the air fryer is instantly ready for preparing another batch.
11. Air Fryer and Parts will become hot during the cooking process.
12. Do not over fill Fry Basket with foods.
13. Do not pack foods into Fry Basket.

Using Oil

Adding a small amount of oil to food can make them crispier.

Oil sprays are good for applying small amounts of oil evenly to food.

Food Tips

You can air fry frozen food that can be baked in the oven.

To make cakes, hand-pies, or any foods with filling or batter, you can place foods in heat-safe container and put that in Fry Basket.

Pat dry foods with marinades before adding to Fry Basket.

Reheating Foods

Simply set temperature to 180°C for up to 10 minutes.

Cooking Guide

Note: these settings are a guide. As ingredients differ in size shape and brand, you may need to adjust cooking times and temperatures.

FOOD	AMOUNT	TIME	TEMPERATURE
CHICKEN	Check food is cooked through with no raw meat and is piping hot.		
Breasts, boneless	200g	17min	190°C
Drumsticks	1.15kg	25min	190°C
Roast Chicken Whole	1.75kg	50-60min	180°C
Legs, bone in	300g	30min	190°C
Tenders	Whole	20min	180°C
Thighs, bone in	110g	22min	190°C
Thighs, boneless	110g	20min	190°C
Wings	1.15kg	15min	190°C
BEEF	Check food is cooked through with no raw meat and is piping hot.		
Roast Beef Joint	1.8kg	45-55min	190°C
Burger	110g	16min	180°C
Filet Mignon	220g	18min	200°C
Flank Steak	680g	12min	200°C
London Broil	900g	20-28min	200°C
Meatballs	1" each	7min	190°C
Ribeye, bone in	220g ,1" thick	10-18min	200°C
Sirloin Steak	340g ,1" thick	9-14min	200°C
PORK AND LAMB	Check food is cooked through with no raw meat and is piping hot.		
Roast Pork Loin Joint	1.25Kg	55 min	180°C
Lamb Loin Chops	1" thick	8-12 min	200°C
Pork Chops, bone in	180g ,1" thick	12 min	200°C

FOOD	AMOUNT	TIME	TEMPERATURE
Pork Chops, boneless	180g ,1" thick	10 min	180°C
Rack of lamb	650g – 900g	22 min	190°C
Tenderloins	450g	15 min	170°C
FISH AND SEAFOOD	Check food is cooked through with no raw meat and is piping hot.		
Calamari Rings	140g	4 min	200°C
Fish Fillet	225g ,1" thick	10 min	200°C
Salmon	170g fillet	12 min	190°C
Scallops	8-10 pieces	5-7 min	200°C
Shrimp	450g	4 min	180°C
Tuna	170g steak	7-10 min	200°C
FROZEN FOODS			
Breaded Scampi	340g	9 min	200°C
Chicken Nuggets	340g	10 min	200°C
Fish Fingers	280g	10 min	200°C
Mozzarella Sticks	310g	8 min	200°C
Onion Rings	340g	8 min	200°C
Waffles	280g	8 min	200°C
Thick French Fries	480g	18 min	200°C
Thin French Fries	560g	14 min	200°C
VEGETABLES			
Asparagus	Stalks	6 min	200°C
Beetroot	Whole	40min	200°C
Broccoli	Florets	6 min	200°C
Brussel Sprouts	Halved	15 min	200°C
Carrots	Slices, ½" thick	15 min	190°C
Cauliflower	Florets	12 min	200°C
Corn on the Cob	Halved	6 min	190°C
Aubergine	1 ½ " cubes	15 min	200°C
Fennel	Quartered	15 min	200°C
Green Beans	Whole	5 min	200°C
Mushrooms	½" slices	5 min	200°C

FOOD	AMOUNT	TIME	TEMPERATURE
Parsnips	½" cubes	15 min	190°C
Peppers	1" chunks	15 min	200°C
Potatoes	680g, small baby	15 min	200°C
Potatoes	French Fries	25 min	200°C
Roast Potatoes	1.5" cubes	30 min	200°C
	(Pre-Boiled)		
Jacket Potato	Whole	40 min	200°C
Squash	½" chunks	12 min	200°C
Sweet Potato	Whole	35 min	190°C
Tomatoes	Cherry	4 min	200°C
Tomatoes	Large Halved	10 min	170°C
Courgette	½" sticks	12 min	200°C

Note: Add 3 minutes to the preparation time before you start frying if the appliance is cold.

Making home-made fries

For the best results, we advise to use pre-baked fries. If you want to make home-made fries, follow the steps below:

1. Peel the potatoes and cut them into sticks.
2. Soak the potato sticks in a bowl of water for at least 30 minutes, take them out and dry them with kitchen paper.
3. Pour 1/2 tablespoon of olive oil in a bowl, put the sticks on top and mix until the sticks are coated with oil.
4. Remove the sticks from the bowl with your fingers or a kitchen utensil so that excess oil stays behind in the bowl. Put the sticks in the basket.
Note: Do not tilt the bowl to put all the sticks in the frying tray in one go, to prevent excess oil from collecting at the bottom of the frying tray.
5. Fry the potato sticks according to the instructions in this chapter.

Cleaning

Clean the appliance after every use.

The frying tray, Crisper rack and the inside of the appliance have a non-stick coating. Do not use metal kitchen utensils or abrasive cleaning materials to clean them, as this may damage the non-stick coating.

1. Remove the mains plug from the wall socket and let the appliance cool down.
Note: Remove the frying tray to let the air fryer cool down more quickly.
2. Wipe the outside of the appliance with a moist cloth.
3. Clean the frying tray and Crisper rack with hot water, some washing liquid soap and a non-abrasive sponge.
You can use a degreasing liquid to remove any remaining dirt.
Note: The frying tray and basket are dishwasher-proof.

Tip: If dirt is stuck to the crisper rack, or at the bottom of the frying tray, fill the frying tray with hot water and with some washing liquid soap. Put the crisper rack in the frying tray and let the frying tray and the crisper rack soak for approximately 10 minutes.

1. Clean the inside of the appliance with hot water and a non-abrasive sponge.
2. Clean the heating element with a cleaning brush to remove any food residues.

Storage

1. Unplug the appliance and let it cool down.
2. Make sure all parts are clean and dry.

Troubleshooting

Problem	Possible cause	Solution
The air fryer does not work	The appliance is not plugged into the mains.	Put the mains plug in an earthed wall socket.
	You have not set the timer.	Turn the timer knob to the required preparation time to switch on the appliance.
The ingredients fried with the air fryer are not done.	The amount of the ingredients in the basket is too much.	Put smaller batches of ingredients in the basket. Smaller batches are fried more evenly.
	The set temperature is too low.	Turn the temperature control knob to the required temperature setting (see section 'Settings').
	The preparation time is too short.	Turn the timer knob to the required preparation time (see section 'Settings').
The ingredients are fried unevenly in the air fryer.	Certain types of the ingredients need to be shaken halfway throughout the preparation time.	Ingredients that lie on the top of or across each other (e.g. fries) need to be shaken halfway throughout the preparation time (see section 'Settings').
Fried snacks are not crispy when they come out of the air fryer	You use a type of snack meant to be prepared in a traditional deep fryer.	Use oven snacks or lightly brush some oil onto the snacks for a crispier result.

Cannot slide the pan into the appliance properly.	There is too much food in the basket.	Do not fill the basket beyond the maximum amount indicated in the table on the earlier page.
	The basket is not placed in the pan correctly.	Push the basket down into the pan until you hear a click.
White smoke comes out of the appliance	You are preparing greasy ingredients.	Note that the temperature is well-controlled to be under 180°C, when you fry greasy ingredients in the air fryer.
	The pan still contains greasy residues from the previous use.	White smoke is caused by grease heating up in the pan. Make sure you clean the pan properly after each use.
Fresh potato fries are fried unevenly in the air fryer.	You did not soak the potato sticks properly before you fried them.	Soak the potato sticks in a bowl of water for at least 30 minutes; take them out and dry them with kitchen paper.
	You did not use the right potato type.	Use fresh potatoes and make sure they stay firm during frying.
Fresh potato fries are not crispy when they come out of the air fryer.	The crispiness of the fries depends on the amount of oil and water in the fries.	Make sure you dry the potato sticks properly before you coat them with oil.
		Cut the potato into thinner sticks for a crispier result.
		Add slightly more oil for a crispier result.

Technical Data

Voltage	:	AC220-240V 50/60Hz
Power Consumption	:	1450-1750 W
Protection class	:	1 (This appliance must be earthed)
Model	:	EMAFDD9LWH

Disposal

- Disposal of your old product. Your product is designed and manufactured with high quality materials and components, which can be recycled and reused
- Please make yourself aware of the local collection system for electrical and electronic products.
- Please act according to your local rules and do not dispose of your old products with your normal household waste.
- The correct disposal of your old product will help prevent potential negative consequences for the environment and human health.

Help Line

If you have any question, please feel free to call our supporting hotline 01189 775506 or email us enquiries@electricmania.co.uk

Produced for ELECTRIC MANIA LTD.

Unit 16, Anglo Industrial Park

Fishponds Road, Wokingham

RG41 2AN

Made in China