

Supplier's Name: Long Life Lamp Company
 Supplier's Address: T2 Arundel Rd Uxbridge UB8 2RP UK
 Production Description: Industrial Ceiling Black Cage Lantern Pendant Light
 Model No.: H3121

• General Information

Recommended Bulbs: Energy Rating from A-G IP20	Cap-type (or other electric interface)	E27
	Mains or non-mains	Mains (240V 50Hz AC)
	Energy consumption in on-mode	Max 60 kWh/1000h
	On-mode power	Max 60 W
	Outer dimensions	157mm x 157mm x 1285mm

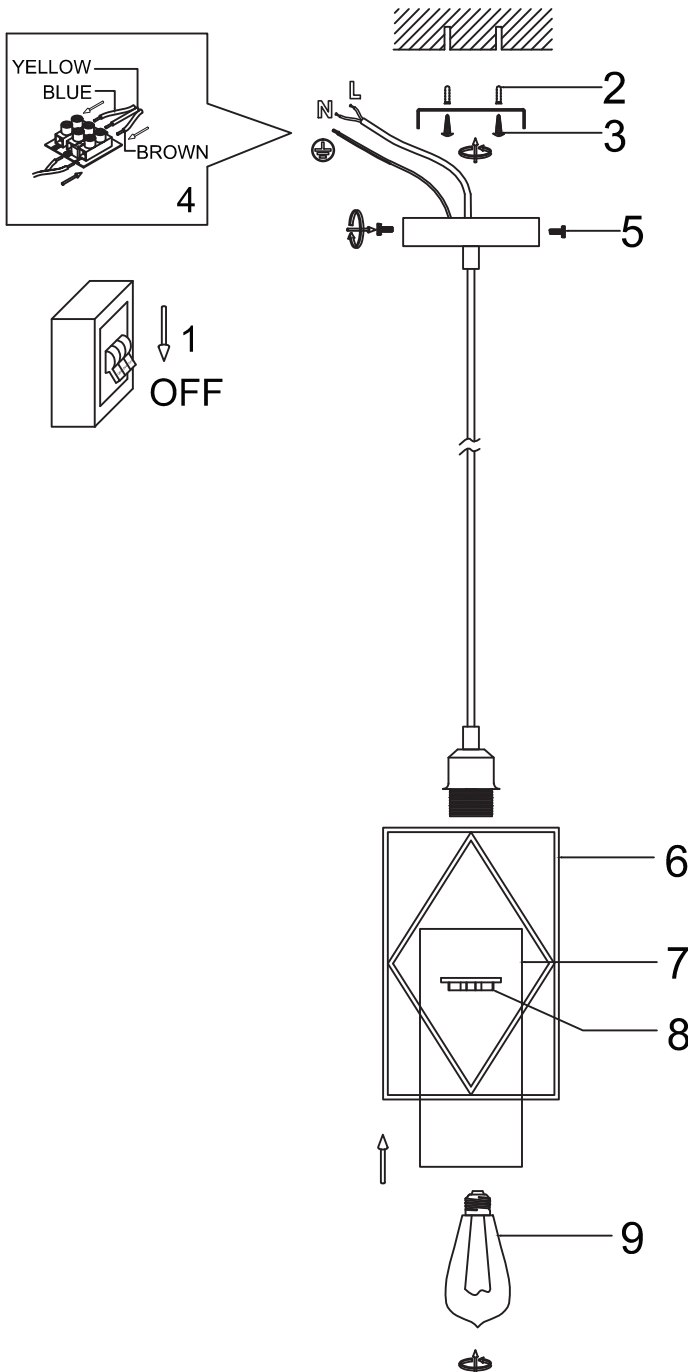
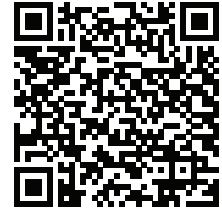

Type Y

To ensure your safety, If the cable becomes damaged, it must be replaced only by a suitably qualified person. If used incorrectly this product can be dangerous. Young people should be given instruction or supervised to ensure it is used safely.

Please note: For Indoor Use ONLY!

Always disconnect from mains and allow to cool before changing bulb, cleaning or moving.

