

Supplier's Name: Long Life Lamp Company
 Supplier's Address: T2 Arundel Rd Uxbridge UB8 2RP UK
 Production Description: Industrial Ceiling Black Pendant Light
 Model No.: H3135

• General Information

Recommended Bulbs: Energy Rating from A-G IP20	Cap-type (or other electric interface)	Built-in Warm White LED + G9
	Mains or non-mains	Mains (240V 50Hz AC)
	Energy consumption in on-mode	5 x 2 + 10 + 3 x Max 28 kWh/1000h
	On-mode power	5 W x 2 + 10 W + 3 x Max 28 W
	Outer dimensions	900mm x 100mm x 1245mm

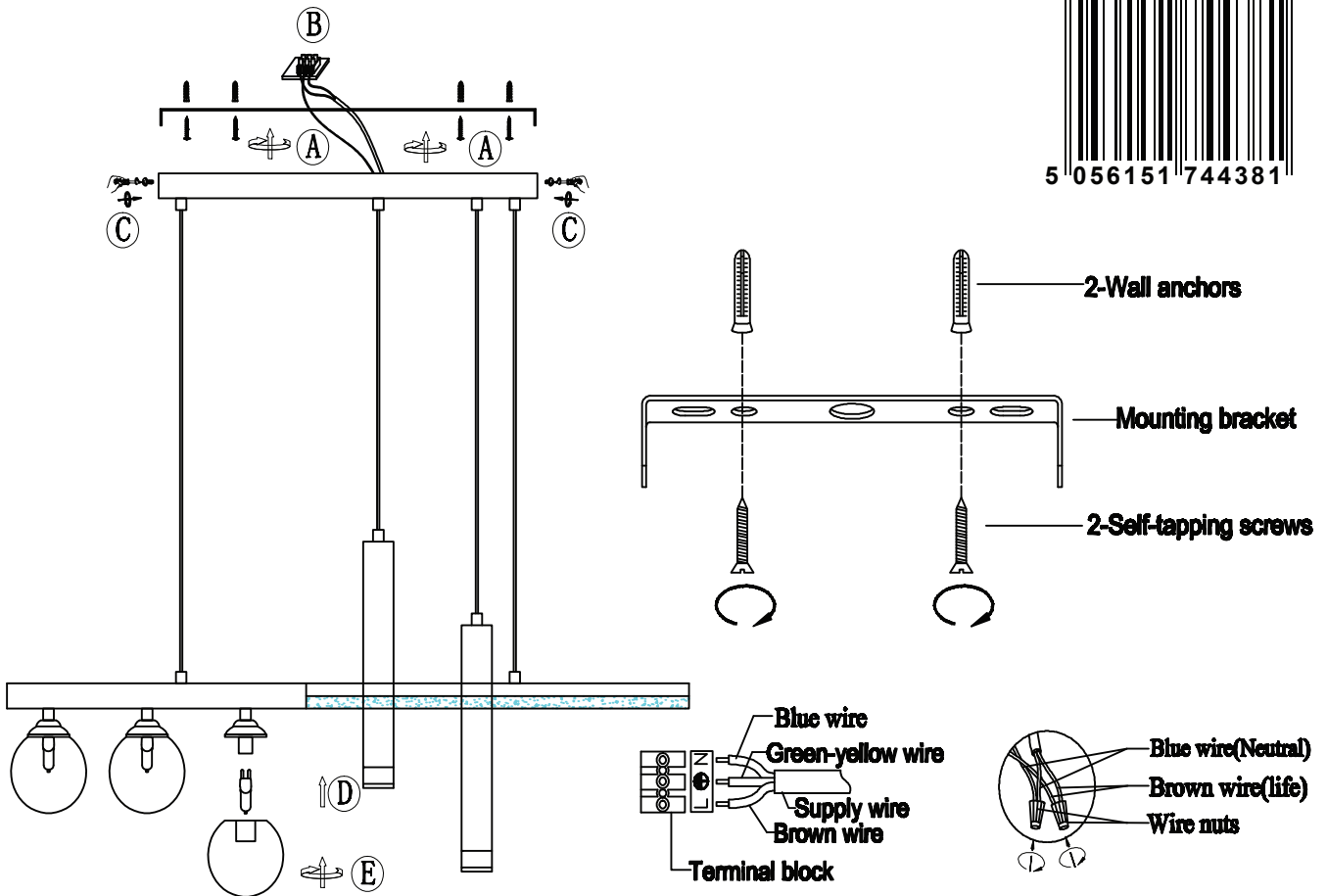

Type Y
 To ensure your safety, If the cable becomes damaged, it must be replaced only by a suitably qualified person. If used incorrectly this product can be dangerous. Young people should be given instruction or supervised to ensure it is used safely.

Please note: For Indoor Use ONLY!
Always disconnect from mains and allow to cool before changing bulb, cleaning or moving.

