

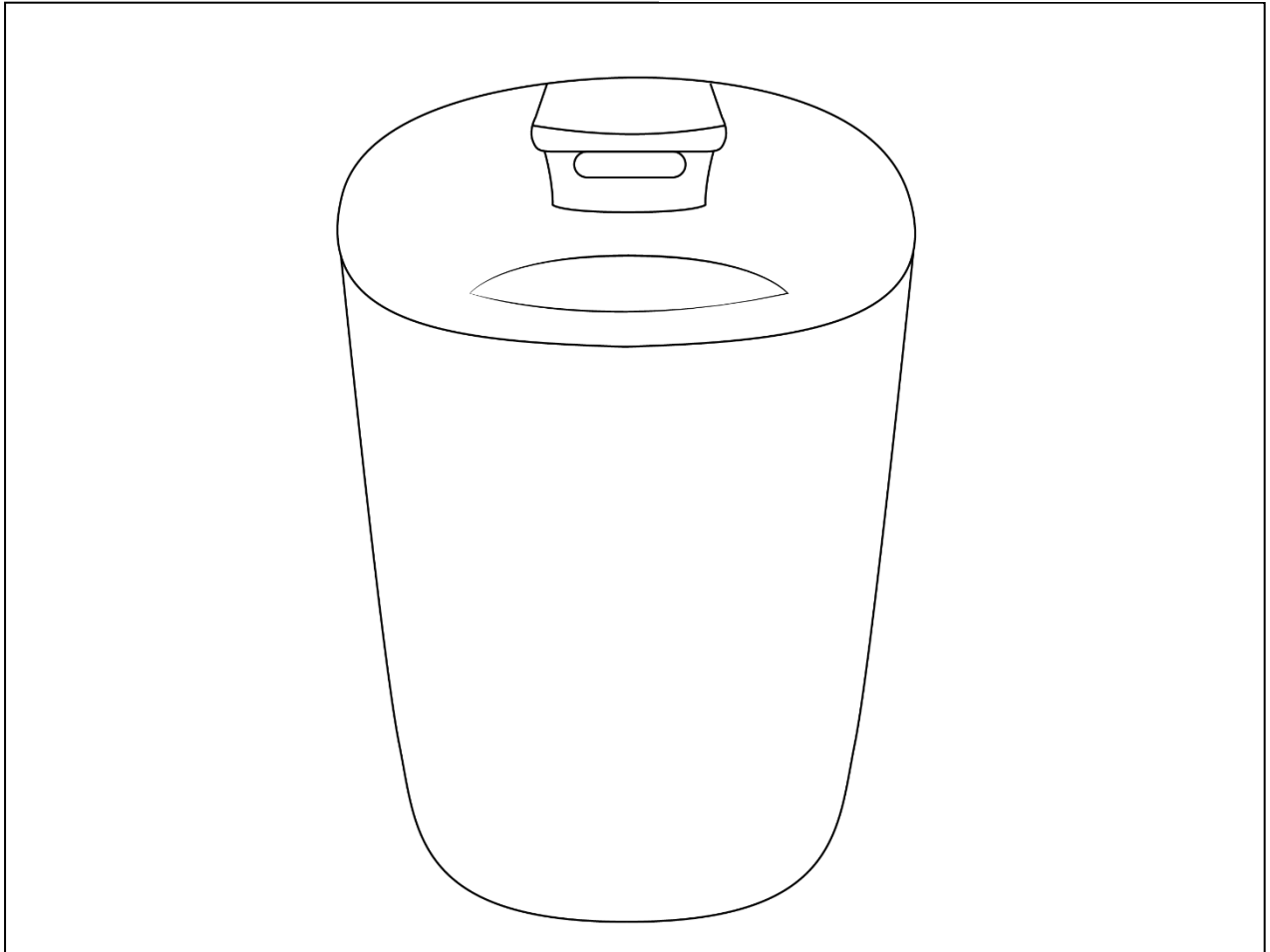

# Russell Hobbs FRESH AIR Operating Manual MINI

RHDH1061



**REGISTER TODAY  
FOR YOUR FREE  
ADDITIONAL YEAR  
GUARANTEE**

# GUARANTEE

At Russell Hobbs, we take all our customer feedback seriously.

Feel free to contact our Product Care Team, on **0345 209 7461** who will be more than happy to assist you.

This product is guaranteed for 12 months from the date of the original purchase. If any defect arises due to faulty materials or workmanship, the faulty product must be returned to the place of purchase.

Refund or replacement is at the discretion of the retailer.

The following conditions apply:

- The product must be returned to the retailer with the original proof of purchase.
- The product must be installed and used in accordance with the instructions contained in this instruction guide and any other instructions for use which are supplied.
- It must be used for domestic purposes only and for its intended use.
- This guarantee does not cover wear and tear, damage, misuse or consumable parts.
- This does not affect your statutory rights.

## RUSSELL HOBBS CONTACT DETAILS

**Website:** [mda.russellhobbs.com](http://mda.russellhobbs.com)

**Telephone:** 0345 209 7461

**Address:** Product Care, Green Bank Business Park,  
Hindley Green, Wigan, WN2 4AY

Note your serial number below for future reference.



*Image for illustration purposes only*

## REGISTER ONLINE

Visit our website to register your full parts and labour guarantee online.

[mda.russellhobbs.com](http://mda.russellhobbs.com)

## REGISTER BY PHONE

Call our friendly Product Care team on the number below.

0345 209 7461

# IMPORTANT SAFETY INSTRUCTIONS

- It is hazardous for anyone other than a competent person to carry out any service or repair operation that involves the removal of a cover which gives protection against exposure to electrical parts.
- Do not use with a damaged cord or plug. If the supply cord is damaged, it must be replaced by the manufacturer, its service agent or similarly qualified persons in order to avoid a hazard.
- This product is intended for household use only.
- Do not use outdoors.
- This appliance can be used by children aged from 8 years and above and persons with reduced physical, sensory or mental capabilities or lack of experience and knowledge if they have been given supervision or instruction concerning use of the appliance in a safe way and understand the hazards involved. Children should not play with the appliance. Cleaning and user maintenance should not be made by children without supervision.
- Do not operate this appliance for anything other than its intended use.
- Do not immerse whole unit in water or other liquids for cleaning.
- Unplug from outlet when not in use. Do not leave unattended while plugged in.
- Do not use if it has been dropped, damaged, left outdoors or dropped into water.
- Keep the appliance away from water; do not allow it to get wet. If unit is wet, do not plug unit into wall socket or turn unit on.
- Do not handle the appliance with wet hands.
- Do not pull or carry by cord, use cord as a handle, close door on cord, pull cord around sharp corners or edges, or expose cord to heated surfaces. Do not unplug by pulling on cord.
- To protect against electrical shock do not immerse cord, plug, or appliance in water or other liquid.
- Unplug from the mains outlet when not in use, before putting on and taking off parts, and before cleaning.
- Only use the unit when fully assembled.
- Never place your fingers or other objects into any part of the appliance. Be aware that loose clothing or hair may become trapped in the appliance if improperly used.
- Before use, ensure that all of the air vents of the appliance are clear and there is no restriction of air flow.
- Caution: Appliance may disturb ashes in an open fire. Always avoid directing the appliance toward naked flames.

The 'wheelie bin' symbol is known as the 'Crossed-out wheelie bin Symbol'. When this symbol is marked on a product/batteries, it means that the product/batteries should not be disposed of with your general household waste. Only discard electrical/electronic/battery items in separate collection schemes, which cater for the recovery and recycling of materials contained within. Your co-operation is vital to ensure the success of these schemes and for the protection of the environment. For your nearest disposal facility, visit [www.recycle-more.co.uk](http://www.recycle-more.co.uk) or ask in store for details.

We reserve the right, due to possible changes to design, to alter the instruction manual without prior notice.

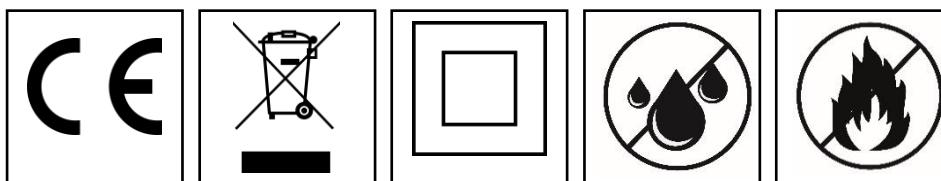

# PARTS

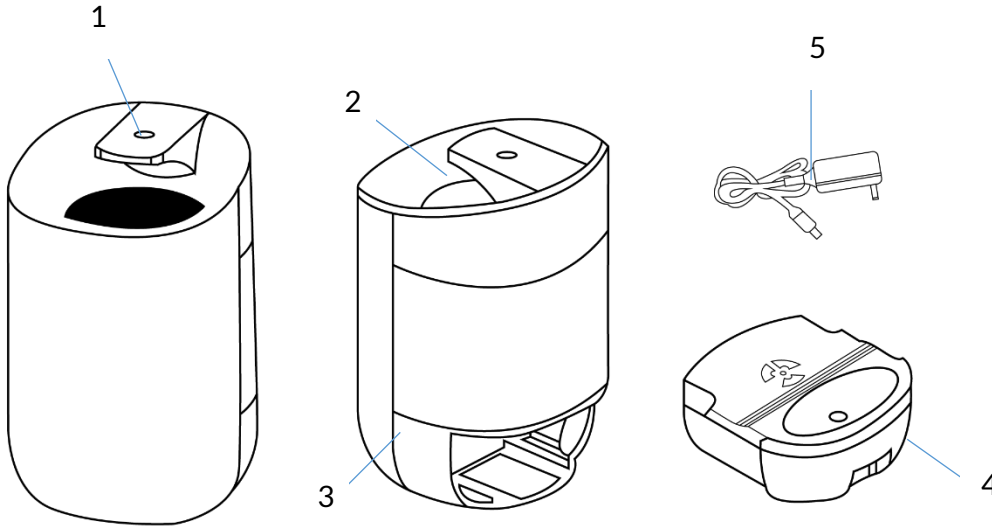

1. On/Off Button
2. Power Light
3. Power Socket
4. Water Tank
5. Plug Adaptor

# ASSEMBLY

1. Remove the Plug Adaptor [5] from the Water Tank [4].
2. Replace Water Tank [4] into Dehumidifier.
3. Plug Adaptor [5] into Socket [3] and into Mains Plug Socket.
4. Power on by pressing the On/Off Button [1].
5. Light will illuminate the top section, and the Dehumidifier is now operating.

To turn the Light Indicator On or Off, hold the On/Off Button [1] for 3 seconds.

# FULL WARNING

The water tank has a maximum capacity of 600ml, and an operating capacity of 300ml/day.

When the Water Tank is full, the Light illumination will turn orange and flash, and the unit will stop operating.

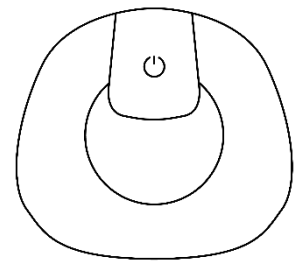

# EMPTYING THE WATER TANK

*Ensure Dehumidifier is switched off at mains, and Adaptor is removed for safety.*

*Do not tilt the dehumidifier when the tank is full.*

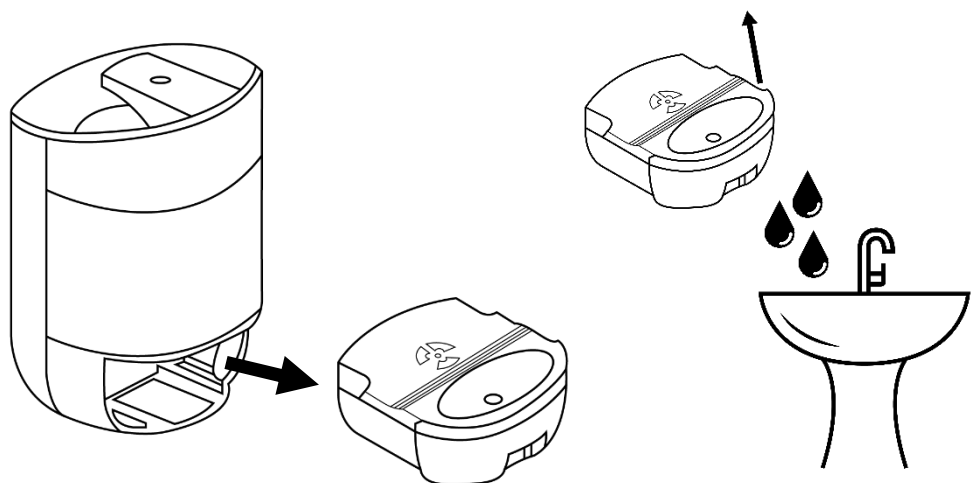

## PROBLEM SOLVING

|   |  |
|---|--|
| The dehumidifier doesn't switch on      | <ul style="list-style-type: none"><li>• Check if the water tank is full and empty if full.</li><li>• Check the dehumidifier is plugged in</li><li>• Check the socket is switched on</li><li>• Check another appliance in the socket</li><li>• Unplug and check for any obvious signs of damage to cord or plug</li><li>• If there is frost on the surface, allow to defrost.</li><li>• If recently used, allow to cool for 1 hour then try again</li></ul> |
| Unit has stopped operating              | <ul style="list-style-type: none"><li>• If ambient temperature drops to 12°C, the unit will be operating at 0°C, and to prevent frost build up the Frost Protection will start heating up.</li></ul>   |
| The dehumidifier is rattling            | <ul style="list-style-type: none"><li>• Check the water tank is secured properly</li><li>• Check there is nothing in contact with the dehumidifier</li></ul>   |
| Dehumidifier is making a grinding sound | <ul style="list-style-type: none"><li>• Immediately switch off and contact Customer Services</li></ul>   |
| Light hasn't turned on                  | <ul style="list-style-type: none"><li>• Check the appliance has switched on as first solution above.</li><li>• Hold the On/Off Button for 3 seconds.</li></ul>   |

If you are still experiencing difficulties with the appliance please contact us **BEFORE** returning the appliance to the retailer it was purchased from:

Website: [mda.russellhobbs.com](http://mda.russellhobbs.com)

Telephone: 0345 209 7461

Address: Product Care, Green Bank Business Park,  
Hindley Green, Wigan, WN2 4AY

# IMPORTANT!

# 3

## MONTHS

### KEEP DEHUMIDIFIER CLEAN

Wipe the top with a damp cloth at least once every 3 months.  
The appliance may require more frequent washing if in a dusty environment.



This product is guaranteed for 12 months from the date of the original purchase. If any defect arises due to faulty materials or workmanship, the faulty product must be returned to the place of purchase.

By registering your product you will get an additional year guarantee free of charge. Additional cover can be purchased through the website.

### REGISTER ONLINE

Visit our website to register your full parts and labour guarantee online.

[mda.russellhobbs.com](http://mda.russellhobbs.com)

### REGISTER BY PHONE

Call our friendly Product Care team on the number below.

0345 209 7461

# NOTES

**REGISTER YOUR FREE  
ADDITIONAL YEAR  
GUARANTEE TODAY**

[mda.russellhobbs.com](http://mda.russellhobbs.com)  
Product Care, G2S Ltd, Green Bank Business Park,  
Swan Lane, Hindley Green, Wigan, WN2 4AY



# Russell Hobbs

Russell Hobbs is a registered trademark used under license from Spectrum Brands (UK) Ltd. Made under license by Product Care Trading Limited, Wigan, WN2 4AY/ PCT (NI) Ltd, Belfast, BT5 5AD

Russell Hobbs Support: call 0345 209 7461 or visit  
[mda.russellhobbs.com](http://mda.russellhobbs.com)

UK  
CA

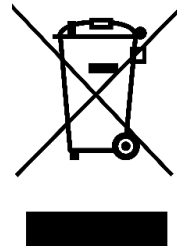
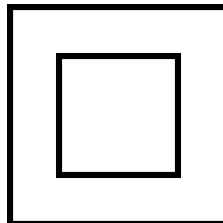

The 'wheellie bin' symbol is known as the 'Crossed-out wheellie bin Symbol'. When this symbol is marked on a product/batteries, it means that the product/batteries should not be disposed of with your general household waste. Only discard electrical/electronic/battery items in separate collection schemes, which cater for the recovery and recycling of materials contained within. Your co-operation is vital to ensure the success of these schemes and for the protection of the environment. For your nearest disposal facility, visit [www.recycle-more.co.uk](http://www.recycle-more.co.uk) or ask in store for details.

SEDEX – Connecting businesses and their global suppliers to share ethical data and enabling improvement in ethical performance. Visit [www.sedex.org.uk](http://www.sedex.org.uk) for further information.

We reserve the right, due to possible changes to design, to alter the instruction manual without prior notice.