



# Russell Hobbs

## 11000BTU Portable Air Conditioner



**Model Number: RHPAC11001**  
**220-240V AC 50Hz**

For Customer Services & Spare Parts please call **0345 209 7461**  
Or visit us at [mda.russellhobbs.com](http://mda.russellhobbs.com)

**PLEASE RETAIN**  
**FOR FUTURE REFERENCE**

# **CONTENTS**

	<b>Page(s)</b>
Safety Instructions and Electrical Safety	<b>3 - 5</b>
Feature Diagram	<b>6</b>
Control Panel Diagram	<b>7</b>
Installing your Air Conditioner	<b>8 - 10</b>
Installing your Window Kit	<b>11</b>
Display Screen Diagram	<b>12</b>
Using your Air Conditioner	<b>13 - 21</b>
Draining your Air Conditioner	<b>22 - 23</b>
Cleaning your Air Conditioner	<b>24</b>
Start/End of Season Operations	<b>25</b>
Cord Storage Hooks	<b>26</b>
Troubleshooting	<b>27</b>
Spare Parts	<b>29</b>
Specification	<b>30</b>
Notes	<b>31</b>

# Safety Instructions

**Important note:** Please read this booklet before installing and switching on this appliance. The manufacturer assumes no responsibility for incorrect installation and usage as described in this booklet.

- This model uses natural refrigerant gas as part of its cooling system. This gas is known as R290 (Propane) and is environmentally friendly but can be combustible. Care should therefore be taken when handling or transporting the product to ensure that none of the refrigeration circuit components are damaged.
- Do not obstruct ventilation openings on the appliance and never insert your finger or any other object into the air outlet.
- Do not cover the appliance or place any object on the control panel.
- The appliance must not be placed or rested on its power cord.
- Do not use adaptors or extension leads when connecting the appliance to the electrical power supply.
- Do not use the appliance if the plug is damaged.
- Do not pull, twist or damage the power cable.
- Do not plug-in or un-plug the appliance with wet hands to prevent electrical shock.
- Always store the unit in an upright position in order to maintain the compressor working in a proper condition.

# Safety Instructions

- This appliance can be used by children aged from 8 years and above and persons with reduced physical, sensory or mental capabilities or lack of experience and knowledge if they have been given supervision or instruction concerning use of the appliance in a safe way and understand the hazards involved. Children should not play with the appliance.
- This appliance is designed to be used by adults, do not allow children to play with the appliance.
- The appliance is intended for residential use only.
- When defrosting and cleaning the appliance, do not use any tools other than those recommended by the manufacturing company.
- The appliance must be installed, used and stored in an area that is greater than 13 m<sup>2</sup>.
- The appliance must be placed in an area without any continuous sources of ignition (for example: open flames, gas or electrical appliances in operation).
- R290/R32 is a refrigerant gas that complies with the European directives on the environment. Do not puncture or damage any part of the refrigerant circuit.
- If the appliance is installed, operated or stored in a non-ventilated area, the room must be designed to prevent the accumulation of refrigerant leaks.
- Individuals who operate or work on the refrigerant circuit must have the appropriate certification issued by an accredited organisation that ensures competence in handling refrigerants according to a specific evaluation recognized by associations in the industry.

# Safety Instructions

- Maintenance and repairs that require the assistance of other qualified personnel must be performed under the supervision of an individual specified in the use of flammable refrigerants.
- Be aware that the refrigerants may not contain an odour.
- Compliance with national gas regulations shall be observed.
- The appliance shall be stored so as to prevent mechanical damage from occurring.
- **WARNING:** System contains refrigerant under very high pressure. The system must be serviced and repaired as recommended by the equipment manufacturer and by qualified persons only.
- Do not use in the following locations: -
  - Next to a source of fire.
  - An area where oil is likely to splash.
  - An area exposed to direct sunlight.
  - An area where water is likely to splash.
  - Near a bath, shower or a swimming pool.
  - In a greenhouse.
  - An area where flammable gasses or liquids are present.

# Electrical Safety



## THIS APPLIANCE MUST BE PLUGGED INTO AN EARTHED SOCKET

- Before switching on, make sure that the voltage of your electricity supply is the same as that indicated on the rating plate. This product is designed to operate on 220 – 240V AC; 50Hz. Connection to any other power source may damage the unit.
- This product may be fitted with a non rewireable plug. If it is necessary to change the fuse in the plug, the fuse cover must be refitted. If the fuse cover becomes lost or damaged, the plug must not be used until a suitable replacement is obtained.
- If the plug has to be changed because it is not suitable for your socket, or becomes damaged in any way, it should be cut off and an appropriate plug fitted. This should be carried out by a qualified electrician. The plug removed must be disposed of safely, as insertion into a 13 Amp socket is likely to cause an electrical hazard.

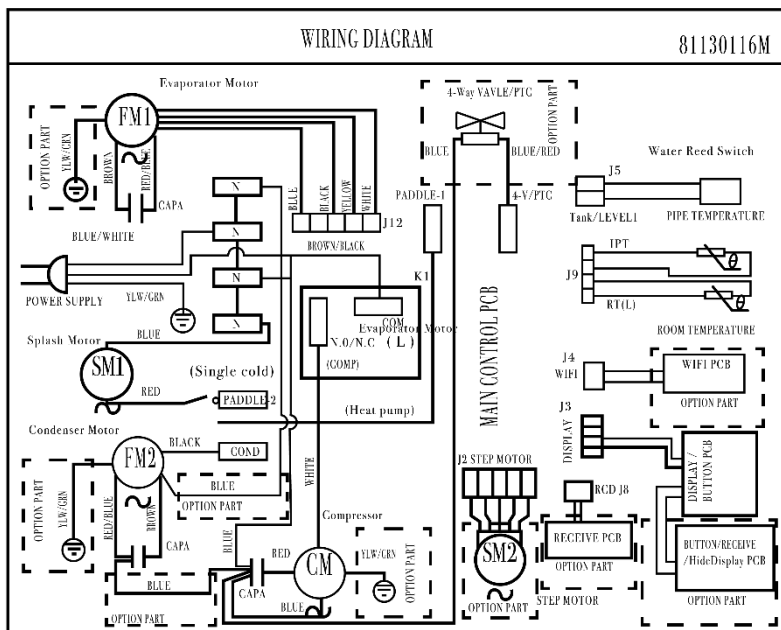

# FEATURE DIAGRAM

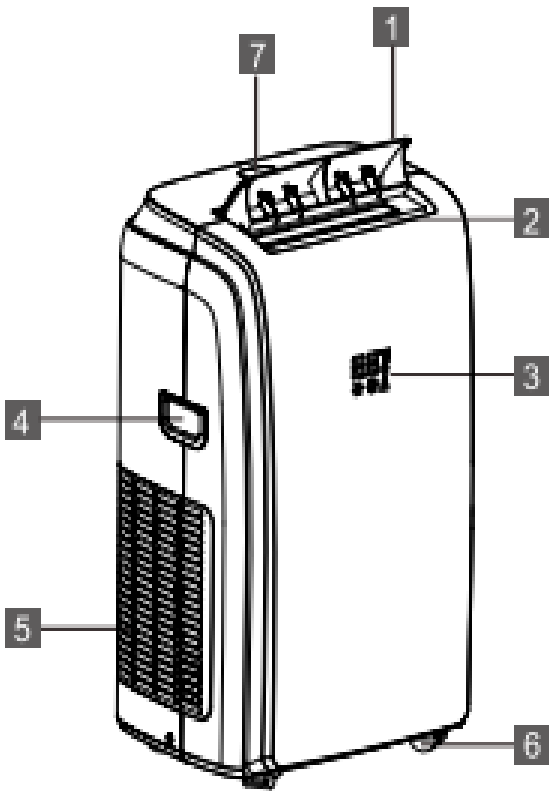

## Front

1. Deflector
2. Air Outlet Grille
3. Display Screen
4. Handle (both sides)
5. Intake Grille
6. Castors
7. Control Panel

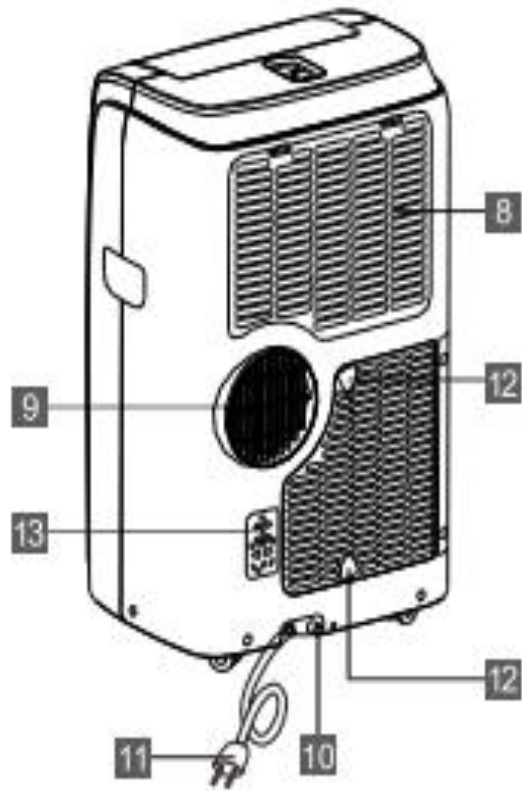

## Rear

9. Intake Grille
10. Condenser Drain
11. Power Cable
12. Holes for Cord Storage Hooks
13. Plug Storage Holder

For Customer Services & Spare Parts please call **0345 209 7461**  
Or visit us at **mda.russellhobbs.com**

# CONTROL PANEL DIAGRAM

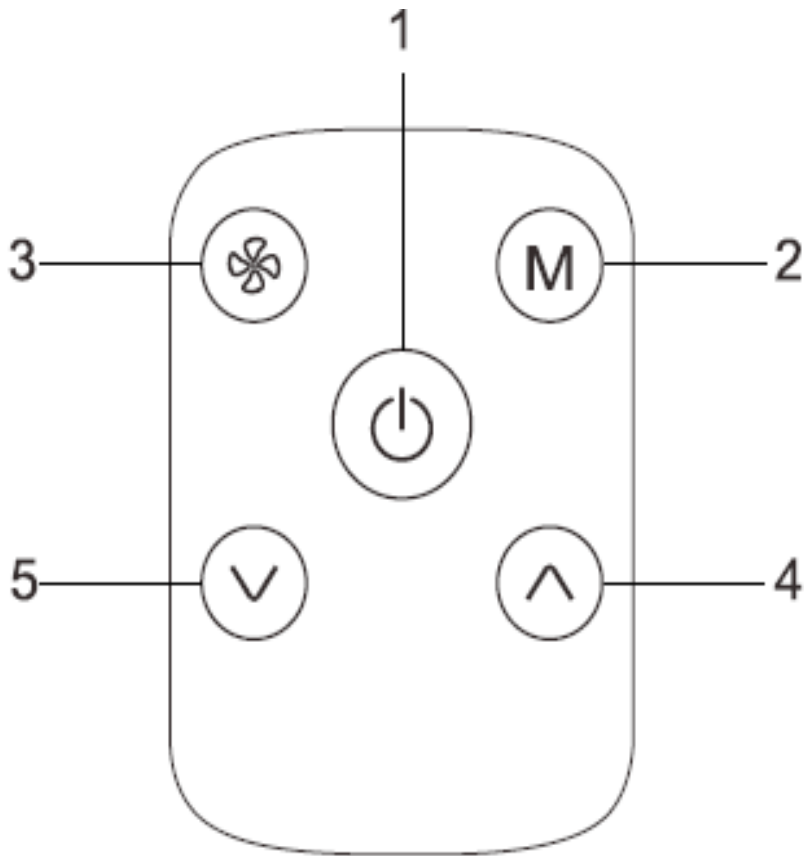

1. ON/OFF button
2. Mode button
3. Fan button
4. Increase button
5. Decrease button

# INSTALLING YOUR AIR CONDITIONER

## Exhausting Hot Air

In the COOL mode the appliance must be placed close to a window or opening so that the warm exhaust air can be ducted from outside.

First position the unit on a flat floor and make sure there is a minimum of a 45cm (18inch) clearance around the unit and ensure this is within the vicinity of a plug socket.

1. Extend either side of the hose (Fig. 1) and screw on the hose inlet (Fig. 2).
2. Extend the other side of the hose and screw it into the hose outlet (Fig. 3)
3. Install the hose inlet into the unit (Fig. 4)
4. Affix the hose outlet into the window seal kit and zip.

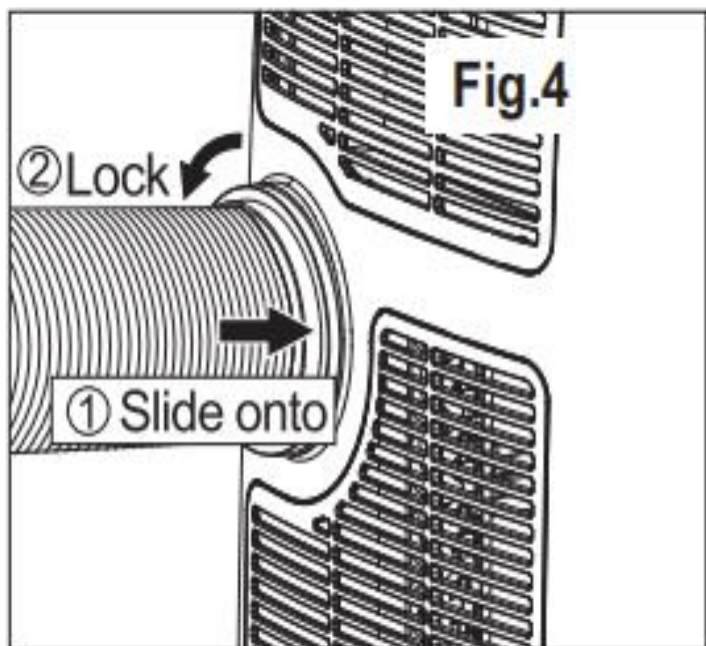
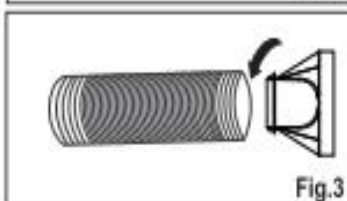
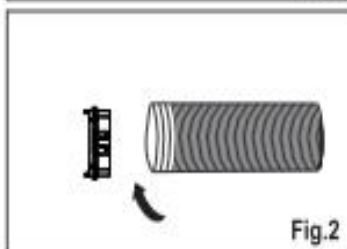
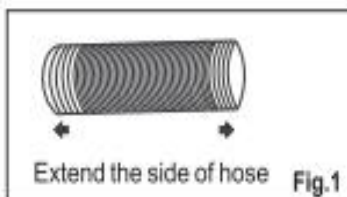

# INSTALLING YOUR AIR CONDITIONER

## Location

- The unit should be placed on firm ground to help minimise noise and vibration. For safe and secure positioning, place the unit on a smooth, level floor which is strong enough to support the unit.
- This unit has castors to aid placement but it should only be rolled on smooth, flat surfaces. Use caution when rolling on carpeted and wooden surfaces. Do not attempt to roll the unit over other objects.
- The unit must be placed within reach of a properly rated grounded socket.
- Never place any obstacles around the air inlet or outlet of the unit.
- Allow at least 45cm of space around, above and away from the wall to ensure the appliance works efficiently.
- The hose can be extended but it is best to keep it to the minimum length required. Also ensure that the hose does not have any sharp bends or sags.

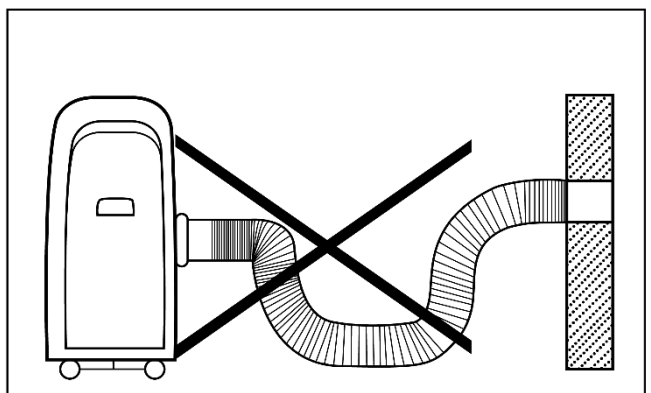
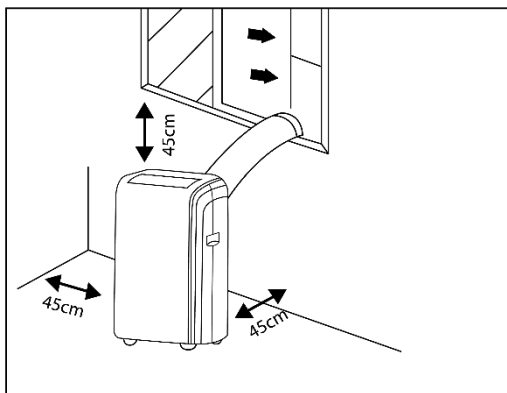

# INSTALLING YOUR WINDOW KIT

Your Russell Hobbs Air Conditioner has been supplied with a Window Sealing Kit. The kit is suitable for use on UPVC windows that open internally or externally either 3 sides, or 4 sides. It is not suitable for middle opening windows such as skylights, or wooden frames.

The maximum aperture dimensions of the kit is 400cm. To measure the dimensions of a 4 point window, measure the frame on all 4 sides. For a 3 point window, measure the frame on the open sides only.

To install this window seal, whilst the window is closed, apply the Velcro tape on both the inside frame of the window, and the frame of the window as shown by the dotted lines. Ensure that the tape is not clamped or in a position it will become clamped.

Apply the long side of the seal kit to the outside frame, and the short side to the inside window.

Open the window, and ensure there is a sufficient seal.

Open the zip, and thread your air conditioner hose through the opening, then tighten the zip.

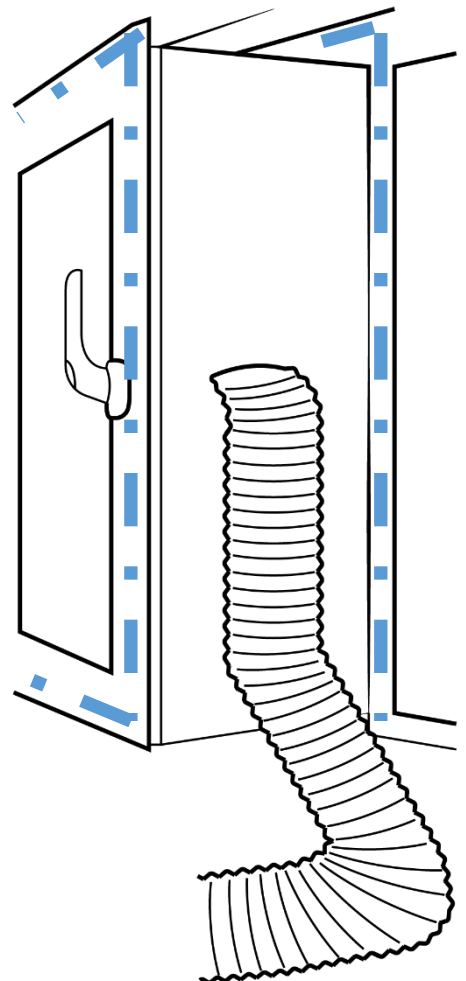

# DISPLAY SCREEN DIAGRAM

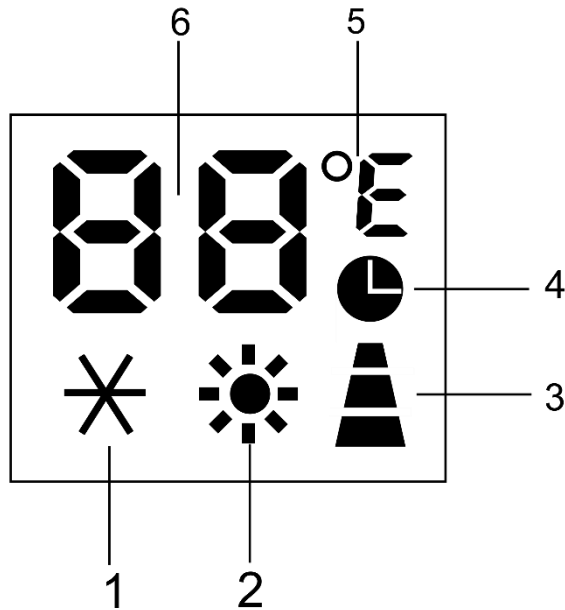

1. Cool symbol
2. Heat symbol\*
3. Fan speed indicator
4. Timer symbol
5. Temperature symbol
6. Temperature indicator

\*only on models with Heat Pump functionality

# USING YOUR AIR CONDITIONER

## Operating from the control panel

*The control panel is on top of the appliance and it enables you to manage functions without using the remote control. However, to use the appliance to its full potential you are advised to use the remote control.*

To turn the appliance on plug it into a mains socket and the appliance will enter standby mode.

Press the ON/OFF button to turn the appliance on, the last function that was active when the appliance was turned off will appear.

***“Never turn the appliance off by unplugging it from the mains. Always press the ON/OFF button, then wait for a few minutes before unplugging. This allows the appliance to perform a cycle of checks to verify the operation”***

## COOL Mode

Ideal for hot humid weather when you need to cool and dehumidify the room.

To set this mode correctly:

- Press the ‘M’ button several times until the COOL symbol appears.
- Select the desired temperature by pressing the INCREASE and DECREASE buttons until the value you want is displayed. The temperature ranges from 18-32°C (64-90°F) in this mode.
- Select the required fan speed by pressing the FAN button.
- There are 4 fan speeds to choose from: High/Medium/Low/Auto



**High Speed:** For maximum fan power



**Medium Speed:** Reduces noise levels but still maintains a good level of comfort



**Low Speed:** For silent operation



**Auto Speed:** The appliance will automatically select the most suitable fan speed in relation to the temperature which it is set at

# USING YOUR AIR CONDITIONER

## HEAT Mode\*

‘\*’ means only the heat pump model have this function.

To set this mode correctly:

- Press the ‘M’ button several times until the HEAT symbol appears.
- Select the desired temperature by pressing the INCREASE and DECREASE buttons until the value you want is displayed. The temperature ranges from 13-27°C (55-81°F) in this mode.
- Select the required fan speed by pressing the FAN button.
- There are 4 fan speeds to choose from: High/Medium/Low/Auto



**High Speed:** For maximum fan power



**Medium Speed:** Reduces noise levels but still maintains a good level of comfort



**Low Speed:** For silent operation



**Auto Speed:** The appliance will automatically select the most suitable fan speed in relation to the temperature which it is set at

## FAN Mode

When using the appliance in this mode, the air hose does not need to be attached.

To set this mode correctly:

- Press the ‘M’ button several times until the  symbol appears.
- Select the required fan speed by pressing the FAN button.
- There are 3 fan speeds to choose from: High/Medium/Low



**High Speed:** For maximum fan power



**Medium Speed:** Reduces noise levels but still maintains a good level of comfort



**Low Speed:** For silent operation

# USING YOUR AIR CONDITIONER

## DRY Mode

Ideal to reduce room humidity (good for use in spring, autumn, damp rooms and rainy periods)

When in DRY mode the appliance should be prepared in the same way as for COOL mode, with the air exhaust hose attached to enable the moisture to be discharged outside.

To set this mode correctly:

- Press the 'M' button several times until the  symbol appears.
- In this mode, the fan speed is automatically selected by the appliance and can not be set manually.

## Switching the unit of temperature

When the appliance is in standby, hold the 'M' button until the appliance beeps (approx. 20 seconds). Once the appliance has beeped you will be able to change the unit of temperature.

For example:

Before change and when in cool mode the screen will display like this.

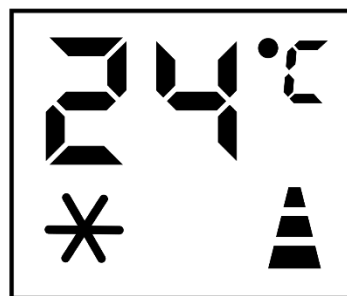

After the change the screen will then display like this.



# USING YOUR AIR CONDITIONER

## Operating from the remote control

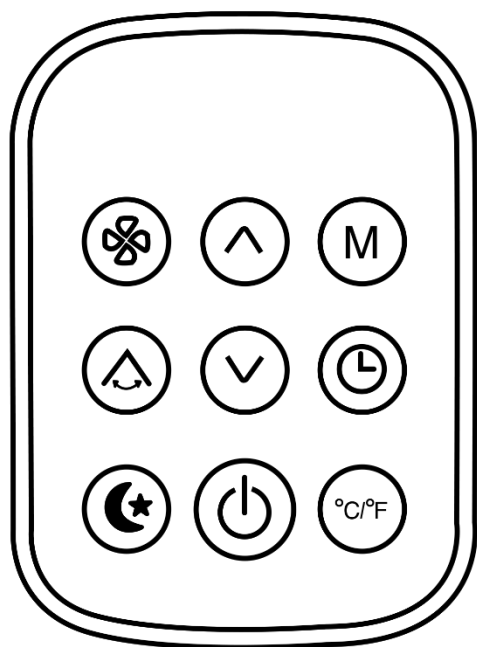

	Fan button
	Oscillating button
	Night Mode button
	Increase button
	Decrease button
	On/Off button
	Mode button
	Timer button
	Unit Switch button

- Point the remote control at the receiver on the appliance.
- The remote control must be no more than 7 meters away from the appliance (without obstacles between the remote control and the receiver).
- The remote control must be handled with extreme care to ensure continuous usage. Do not drop or expose the remote to direct sunlight or sources of heat.

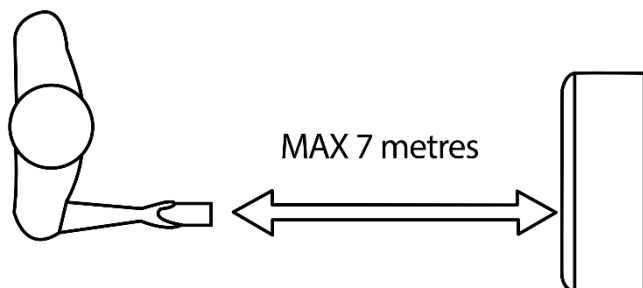

# USING YOUR AIR CONDITIONER

The remote comes with a battery already installed. To use the remote for the first time, remove the transparent insulating strip by pulling it out gently.

## Replacing the Battery

To replace the battery follow the steps below:

1. Press down the pin and remove the battery cover
2. Replace the battery and then reinstall the battery cover into the remote.

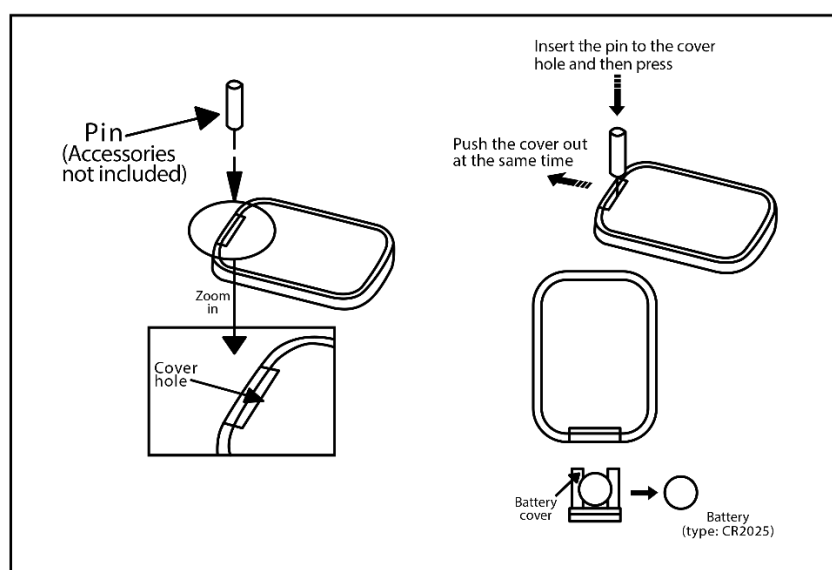

**WARNING: Chemical Burn Hazard – Keep batteries away from children.**

This product contains a lithium button/coin cell battery. If a new or used lithium button/cell battery is swallowed or enters the body, it can cause severe internal burns and can lead to death in as little as 2 hours. Always make sure you completely secure the battery compartment. If the battery compartment does not close securely, stop using the product, remove the battery and keep it away from children. If you think the battery might have been swallowed or placed inside any part of the body, seek immediate medical attention.

The cells should be disposed of correctly, including keeping them away from children, even used cells may cause injury.

# USING YOUR AIR CONDITIONER

## **COOL Mode, HEAT Mode, FAN Mode, DRY Mode**

To correctly set these four modes using the remote control, follow the same steps that are stated in the '**Operating from the control panel**' section of this manual but instead of pressing the buttons mentioned on the control panel press the corresponding buttons on the remote control.

## **Oscillating function**

This function is useful for selecting the up and down flow of air delivery.

To set this function correctly:

- Select the desired operating mode as detailed above.
- Press the OSCILLATING button and the deflector will begin to swing.

## **Night Mode function**

This function is useful for the night as it gradually reduces the operation of the appliance.

To set this function correctly:

- Select the COOL or HEAT mode.
- Press the NIGHT MODE button.

The appliance will then operate in the previously selected mode.

When in this function the display screen will reduce in brightness and the room will be maintained at the optimum temperature without excessive fluctuations in temperature or humidity with silent operation. The fan speed will always be low so you are not disturbed by excessive noise while you sleep.

When in COOL mode, the selected temperature will increase by 1°C (1°F) per hour over a 2-hour period. This new temperature will then be maintained for the next 6 hours. After 6 hours the appliance will turn itself off.

# USING YOUR AIR CONDITIONER

When in HEAT mode, the selected temperature will increase by 1°C (1°F) per hour over a 3-hour period. This new temperature will then be maintained for the next 5 hours. After 5 hours the appliance will turn itself off.

This function can be cancelled at any time during operation by pressing either the NIGHT MODE, MODE or FAN SPEED button.

## Setting the timer

The timer can be used to schedule the start up or shutting down of the appliance.

Programming start up:

- Turn on the appliance and select the mode, temperature and fan speed you desire, then turn off the appliance.
- Press the TIMER button and the screen will display 1-24 hours while the TIMER symbol will flash (Fig. 3).
- Adjust the timer until the desired time is displayed. Wait for approximately 5 seconds and then the timer will then be active. Only the TIMER symbol should be displayed on the screen (Fig. 4).
- Press either the TIMER or the ON/OFF button and the timer will be cancelled. The TIMER symbol will then disappear from the screen.



# USING YOUR AIR CONDITIONER

Programming shut down:

- When the appliance is running press the TIMER button, the screen will then display the hours and several symbols will flash together (Fig. 5).
- Adjust the timer until the desired time is displayed. Wait for approximately 5 seconds and then the timer will be active. Only the TIMER symbol should be displayed on the screen (Fig. 6).
- Press either the TIMER or the ON/OFF button and the timer will be cancelled. The TIMER symbol will then disappear from the screen (Fig. 7).



Fig 5



Fig 6



Fig 7

## Tips for correct use

To get the best out of your appliance, follow these recommendations:

- If possible, close the windows and doors in the room you want to be air conditioned (Fig 21). When installing the appliance semi-permanently you should leave a door slightly open (as little as 1cm) to guarantee correct ventilation.
- Protect the room from direct exposure to the sun by partially closing curtains and/or blinds to make the appliance much more economical to run (Fig 22).
- Never rest objects of any kind on the appliance.
- Do not obstruct the air intake and outlet (Fig 23). Ensure the grills are left free.
- Make sure there are no heat sources within the room.

# USING YOUR AIR CONDITIONER

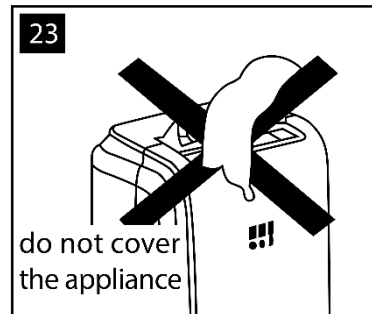
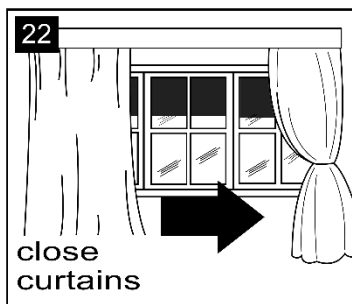
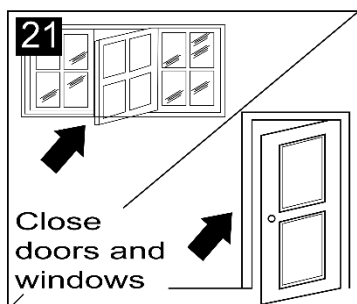

- Never use the appliance in very damp rooms (e.g. Laundry Rooms).
- Never use the appliance outdoors.
- Make sure the appliance is standing on a level surface. If necessary, place the castor locks under the front wheels.



## Self-Diagnosis

This appliance has a self-diagnosis system to help identify a number of malfunctions.

The following error messages will be displayed is the appliance has identified a malfunction.

DISPLAY	WHAT SHOULD YOU DO?
LOW TEMPERATURE 	The appliance is fitted with a frost protection device to avoid the excessive formation of ice. You DO NOT need to do anything when this happens, the appliance will start back up automatically once defrosted.
PROBE FAILURE 	If this is displayed please contact our Customer Service team by calling <b>0345 209 7461</b> .
FULL TANK 	Empty the internal safety tank, following the instructions in the “End of Season Operations” section of this Instruction Manual

# DRAINING YOUR AIR CONDITIONER

## Water drainage method

When there is excess water condensation inside the unit, the appliance will stop running and 'Ft' will display (FULL TANK as mentioned in the self diagnosis). This indicates that water needs to be drained out using one of the following procedures.

### **Manual Draining (Fig. 24)**

Water may need to be drained in high humidity areas.

1. Unplug the unit from the power source.
2. Place a drain pan under the lower drain plug (see Fig. 24).
3. Remove the lower drain plug
4. Water will drain out and collect in the drain pan (drain pans not supplied).
5. After all the water has been drained out, replace the lower drain plug firmly.
6. Plug the unit back into the power source and turn it back on.

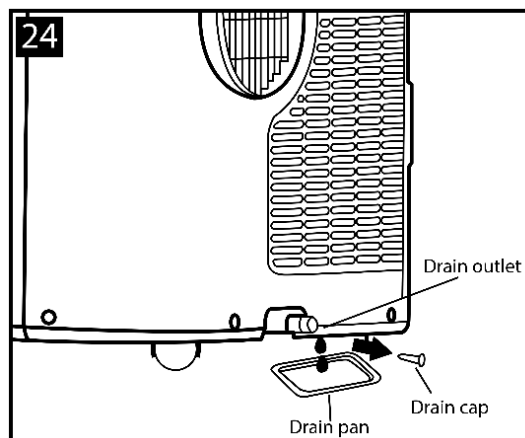

### **Continuous Draining (Fig. 25)**

While using the unit in the dehumidifier mode, it is recommended to use this method of draining.

1. Unplug the unit from the power source.

# DRAINING YOUR AIR CONDITIONER

2. Remove the drain plug. When removing the plug some residual water may spill out, so ensure you have a pan to collect the water.
3. Connect the supplied drain hose to the drain outlet.
4. The water can be continuously drained through the hose into a floor drain or bucket.
5. Plug the unit back into the power source and turn it back on.

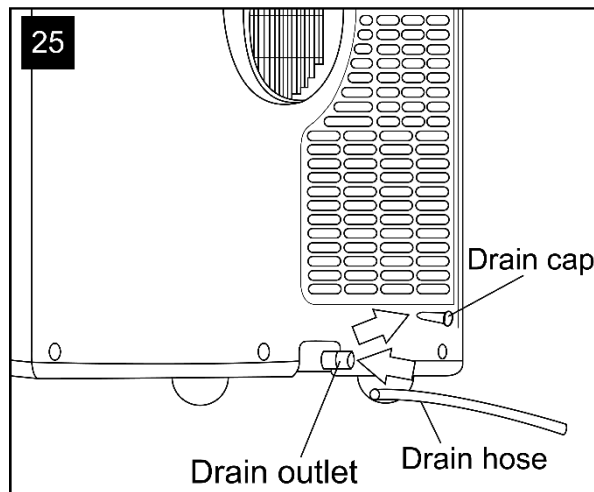

NOTE - Please ensure that the height of and the section of the drain hose should not be higher than the drain outlet , or the water tank may not be drained (Fig. 26 and 27).

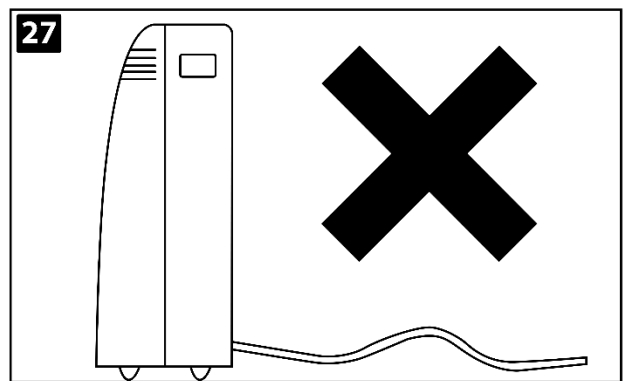
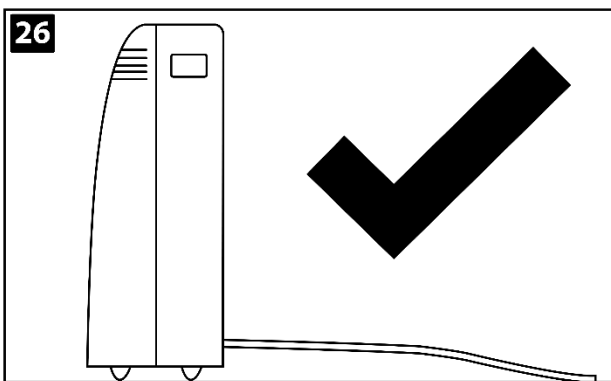

# CLEANING YOUR AIR CONDITIONER

Before any cleaning or maintenance, turn the appliance off by pressing the ON/OFF button on either the control panel or remote control, wait for a few minutes and then unplug the appliance from the mains socket.

## **Cleaning the cabinet**

You should clean the appliance with a slightly damp cloth and then pat dry with a dry cloth.

- Never wash the appliance with water it could be dangerous.
- Never use petrol, alcohol or solvents to clean the appliance.
- Never spray with insecticide or similar liquids.

## **Cleaning the air filters**

To keep your appliance working efficiently, you should clean the filter every week of operation.

You can remove the evaporator filter & condensers as seen in Fig 28-31.

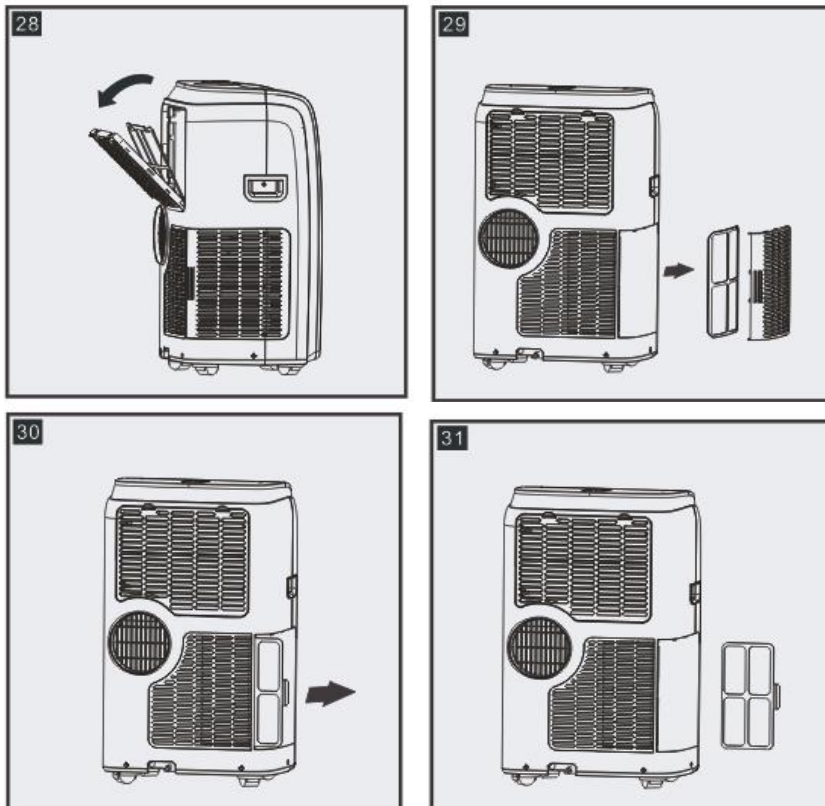

Use a vacuum cleaner to remove dust accumulation from the filter. If it is very dirty, immerse the filter in warm water and rinse it several times, the water should never be hotter than 40°C (104°F). After washing, leave the filter out to dry and then re-attach the intake grill to the appliance.

# START/END OF SEASON OPERATIONS

## Start of season checks

Make sure the power cable and plug are undamaged and the earth system is efficient.

Follow the installation instructions within this manual precisely.

## End of season operations

To empty the internal circuit completely of water, remove the cap (Fig 32) and run all the water off into a pan.

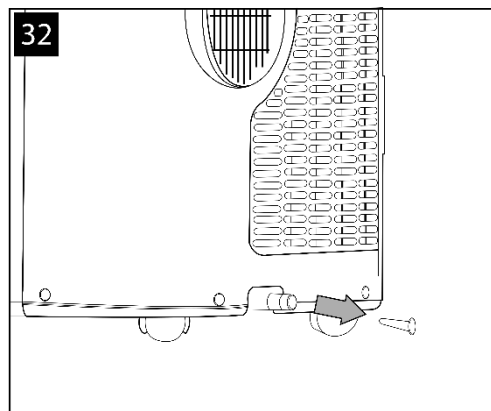

When all the water has been drained, firmly put the cap back in place. Clean the filter and dry thoroughly before putting it back into the appliance.

## Limit conditions

### Cooling Mode

Temperature of room: 18-35°C (64-95°F)

Humidity of room: 30%-90%RH.

### Heating Mode

Temperature of room: 10-25°C (50-77°F).

Humidity of room: 30%-90%RH.

# INSTALLING STORAGE HOOKS

## Installation

Install the hooks by inserting into the below areas, and then turning them 45° clockwise.

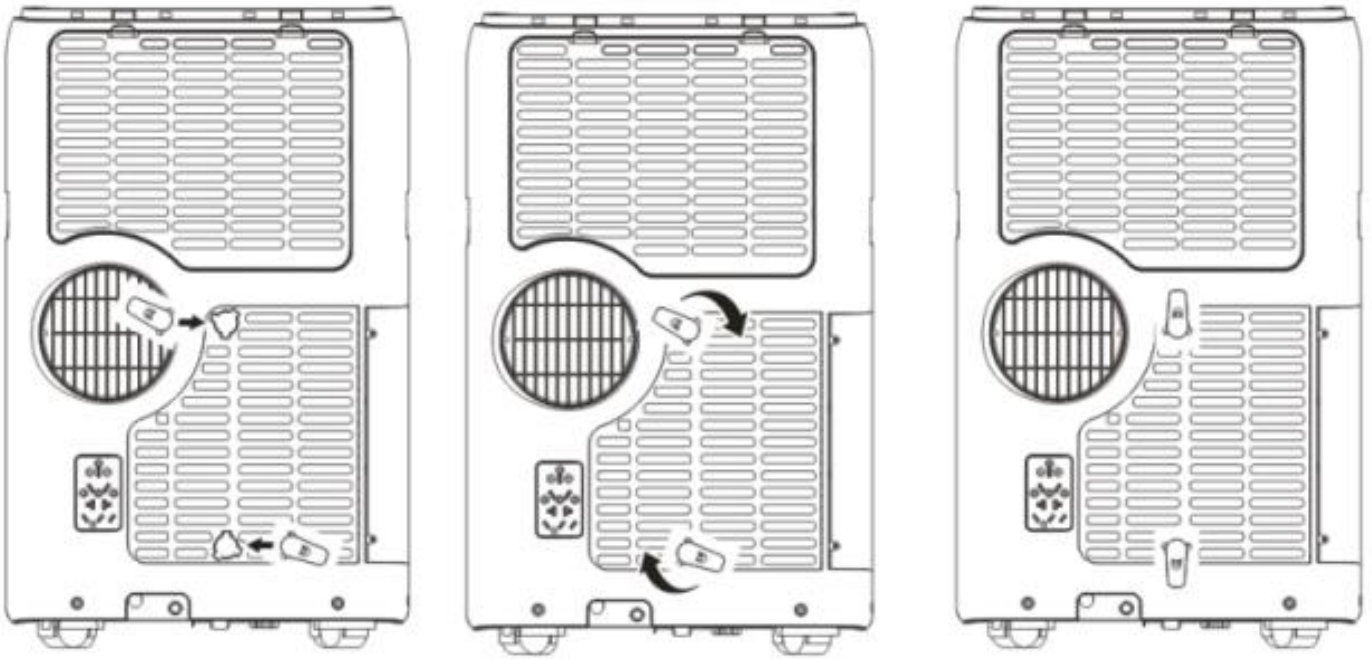

## Cord Storage

Once hooks have been installed as above, power cord can be secured around the hooks.

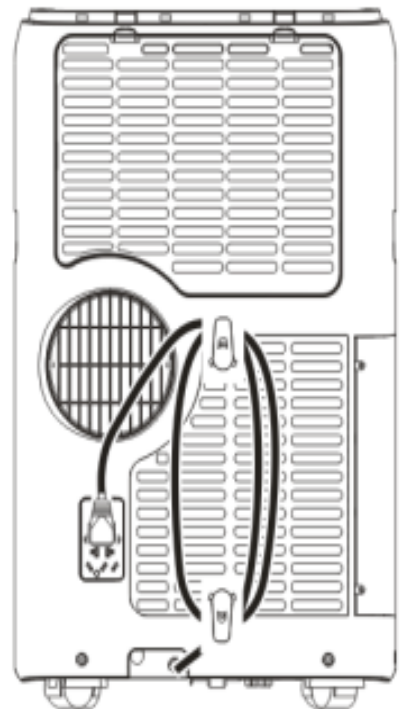

# TROUBLESHOOTING

PROBLEM	CAUSE	SOLUTION
The appliance does not come on	<ul style="list-style-type: none"> <li>-There is no current</li> <li>-It is not plugged into the mains</li> <li>-The internal safety device has tripped</li> </ul>	<ul style="list-style-type: none"> <li>-Wait</li> <li>-Plug it into the mains</li> <li>-Wait 30 minutes and if the problem persists please contact our Customer Service team on <b>0345 209 7461</b>.</li> </ul>
The appliance works for a short time only	<ul style="list-style-type: none"> <li>-There are bends in the air exhaust hose</li> <li>-Something is preventing the air from being discharged</li> </ul>	<ul style="list-style-type: none"> <li>-Position the air exhaust correctly, keeping it as short and free of curves as possible.</li> <li>-Check and remove and obstacles obstructing the air discharge.</li> </ul>
The following message appears on the display: LT/PF/FT	-The appliance has a self-diagnosis system to identify a number of malfunctions	-See the SELF-DIAGNOSIS section of this booklet

# TROUBLESHOOTING

PROBLEM	CAUSE	SOLUTION
<p>The appliance works but does not cool the room</p>	<ul style="list-style-type: none"> <li>-Windows, doors and/or curtains are open</li> <li>-There are heat sources in the room (oven, hairdryer etc.)</li> <li>-The air exhaust hose is detached from the appliance</li> <li>-The technical specification of the appliance is not adequate for the room in which it is located</li> </ul>	<ul style="list-style-type: none"> <li>-Close doors, windows and curtains, bearing in mind the “tips for correct use” given above</li> <li>-Remove the heat sources</li> <li>-Fit the air exhaust in the housing at the back of the appliance</li> </ul>
<p>During operation, there is an unpleasant smell in the room</p>	<ul style="list-style-type: none"> <li>-The air filter is clogged</li> </ul>	<ul style="list-style-type: none"> <li>-Clean the filter as described earlier within this instruction booklet</li> </ul>
<p>The appliance does not operate for about three minutes after restarting it</p>	<ul style="list-style-type: none"> <li>-The internal compressor safety device prevents the appliance from being restarted until three minutes have elapsed since it was last turned off</li> </ul>	<ul style="list-style-type: none"> <li>-Wait, this delay is part of the normal operation of the appliance</li> </ul>

# SPARE PARTS

To check the availability of the following spare parts, simply contact our friendly Customer Services team using the details provided at the bottom of this page.

**Remote Control**

**Exhaust Hose**

For Customer Services & Spare Parts please call **0345 209 7461**  
Or visit us at **[mda.russellhobbs.com](http://mda.russellhobbs.com)**

# SPECIFICATION

<b>Model</b>	RHPAC11001
<b>Voltage</b>	220 - 240V 50Hz
<b>Power Input (Cooling)</b>	1230W
<b>Power Input (Heating)</b>	1035W
<b>Maximum Cooling Capacity</b>	11000 BTU
<b>Suitable Room Size</b>	13-21 (m <sup>2</sup> )
<b>Refrigerant</b>	R290/0.26kg
<b>Overall Size (W x H x D)</b>	44 x 71.5 x 35.5 (cm)
<b>Weight</b>	31 KG
<b>Moisture Removal</b>	1.5 L/hr
<b>Operating Temperature (Cooling)</b>	18°C - 35°C
<b>Operating Temperature (Heating)</b>	10°C - 25°C
<b>Operating Humidity</b>	30%RH ~ 90%RH

# NOTES



# Russell Hobbs

Russell Hobbs is a registered trademark used under license from Spectrum Brands (UK) Ltd. Made under license by

G2S Limited, Wigan, WN2 4AY/G2S (NI) Ltd, Belfast, BT5 5AD

Russell Hobbs Support: call 0345 209 7461 or visit [mda.russellhobbs.com](http://mda.russellhobbs.com)

UK  
CA

C E

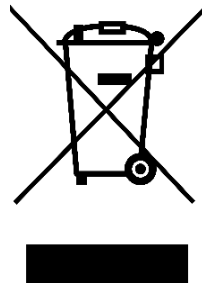

The 'wheele bin' symbol is known as the 'Crossed-out wheele bin Symbol'. When this symbol is marked on a product/batteries, it means that the product/batteries should not be disposed of with your general household waste. Only discard electrical/electronic/battery items in separate collection schemes, which cater for the recovery and recycling of materials contained within. Your co-operation is vital to ensure the success of these schemes and for the protection of the environment. For your nearest disposal facility, visit [www.recycle-more.co.uk](http://www.recycle-more.co.uk) or ask in store for details.

SEDEX – Connecting businesses and their global suppliers to share ethical data and enabling improvement in ethical performance. Visit [www.sedex.org.uk](http://www.sedex.org.uk) for further information.

We reserve the right, due to possible changes to design, to alter the instruction manual without prior notice.