



Russell Hobbs

Operating Manual

16 SERIES

RH914W116W

RH914W116B

RH914W116AN

WASHING MACHINE

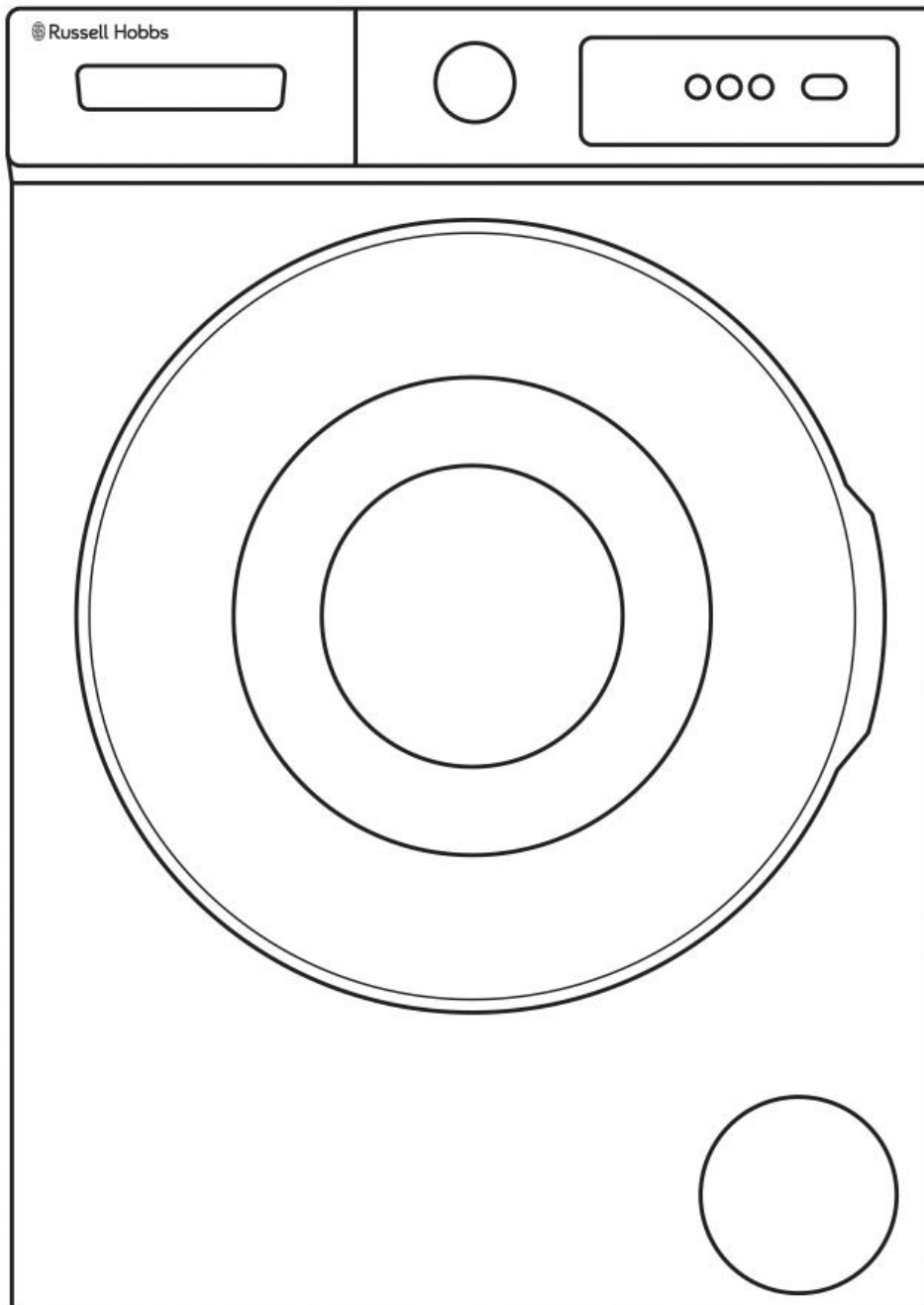

GUARANTEE

At Russell Hobbs, we take all our customer feedback seriously.

Feel free to contact our Customer Service Team who will be more than happy to assist you.

This product is guaranteed for 12 months from the date of the original purchase. If any defect arises due to faulty materials or workmanship, the faulty product must be returned to the place of purchase.

Refund or replacement is at the discretion of the retailer.

The following conditions apply:

- The product must be returned to the retailer with the original proof of purchase.
- The product must be installed and used in accordance with the instructions contained in this instruction guide and any other instructions for use which are supplied.
- It must be used for domestic purposes only and for its intended use.
- This guarantee does not cover wear and tear, damage, misuse or consumable parts.
- This does not affect your statutory rights.

Region	Contact	Website
UK & Northern Ireland	0345 209 7461	mda.russellhobbs.com
Ireland	1 800 938982	ie.mda.russellhobbs.com
Rest of Europe	europe@productcaregroup.com	de.mda.russellhobbs.com fr.mda.russellhobbs.com es.mda.russellhobbs.com it.mda.russellhobbs.com nl.mda.russellhobbs.com

Note your serial number below for future reference.



Image for illustration purposes only

CONTENTS

Page	Section
2	Guarantee
4	Safety Instructions
6	Installation - Transportation
7	Installation - Levelling
8	Installation - Location
9	Installation - Water Inlet
10	Installation – Water Discharge
11	Installation - Detergent Drawer
12	Installation - Stacking
13	Drain Pump Filter
14	Functions & Buttons
15	First Time Use
16	Operation
17	Cleaning & Care
19	Washing Symbols
20	Programs & Times
22	Problem Solving
24	Technical Specification

IMPORTANT SAFETY INSTRUCTIONS

- It is hazardous for anyone other than a competent person to carry out any service or repair operation that involves the removal of a cover which gives protection against exposure to electrical parts.
- If the supply cord is damaged, it must be replaced by the manufacturer, its service agent or similarly qualified persons in order to avoid a hazard. DO NOT use with damaged cord or plug.
- DO NOT use with an extension cable.
- This product is intended for household use only. DO NOT use outdoors.
- This appliance can be used by children aged from 8 years and above and persons with reduced physical, sensory or mental capabilities or lack of experience and knowledge if they have been given supervision or instruction concerning use of the appliance in a safe way and understand the hazards involved. Children should not play with the appliance. Cleaning and user maintenance should not be made by children without supervision.
- DO NOT install on carpet or any surface that would prevent adequate ventilation of the appliance.
- Use only parts and accessories supplied with the appliance, or sourced directly from the manufacturer.
- Do not open the detergent drawer during operation.
- Do not open the door with water still in the appliance.
- Keep the appliance and plug away from water; do not allow it to get wet.

IMPORTANT SAFETY INSTRUCTIONS

- DO NOT use appliance if it has been dropped, damaged, left outdoors or dropped into water. Do not operate this appliance for anything other than its intended use.
- If unit is wet, do not plug unit into wall socket or turn unit on. Do not immerse in water or other liquids for cleaning. DO NOT handle the appliance with wet hands.
- DO NOT pull by the cord, close door on cord, pull cord around sharp corners or edges, or expose cord to heated surfaces.
- The use of accessory attachments not recommended by the manufacturer may cause fire, electric shock or injury. Only use the accessories supplied by the manufacturer.
- Only use the appliance when fully assembled.
- Never place your fingers or other objects into any part of the appliance. Be aware that loose clothing or hair may become trapped in the cleaner if improperly used.
- DO NOT touch water discharge pipe during operation, or water being expelled as it may be hot.
- NEVER wash any fabric, clothes, or any other object that has been exposed to flammable liquids such as petrol, spirits, etc. ALWAYS ventilate and hand wash at least 24 hours prior.
- ALWAYS remove transport bolts prior to first use; any damaged caused by failure to remove bolts will void your guarantee.

INSTALLATION – TRANSPORTATION BOLTS

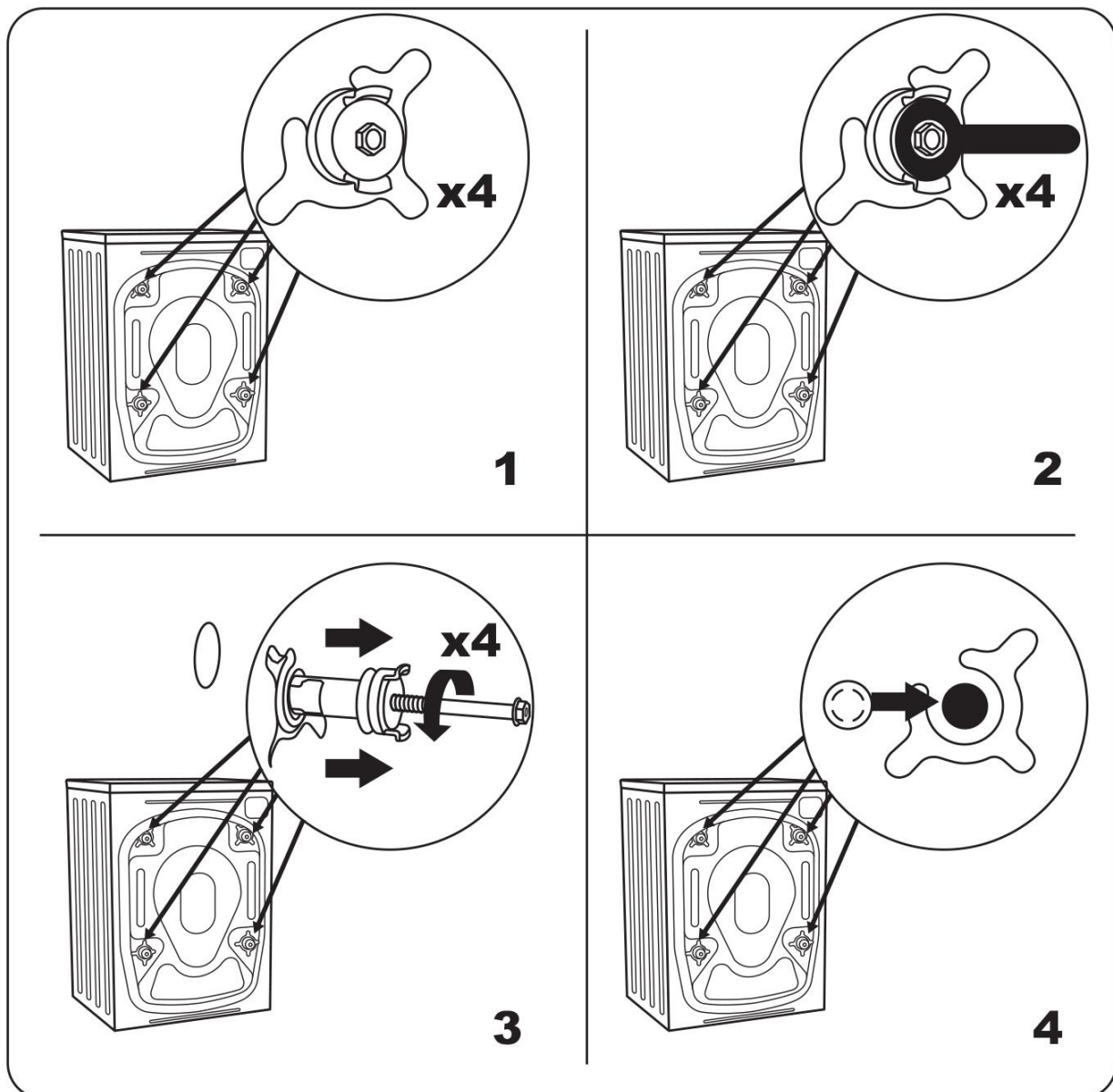

Before Installation, you **MUST** ensure the 4 transportation bolts are removed. Failure to do so will result in damage to the appliance.

Using a 10mm spanner, turn the bolts counter clockwise until they come loose from the white plug stoppers. Once removed, either by hand or using pliers, remove the white plugs also.

Add the 4 blanking caps supplied into the holes left by the bolts.

INSTALLATION – LEVELLING THE FEET

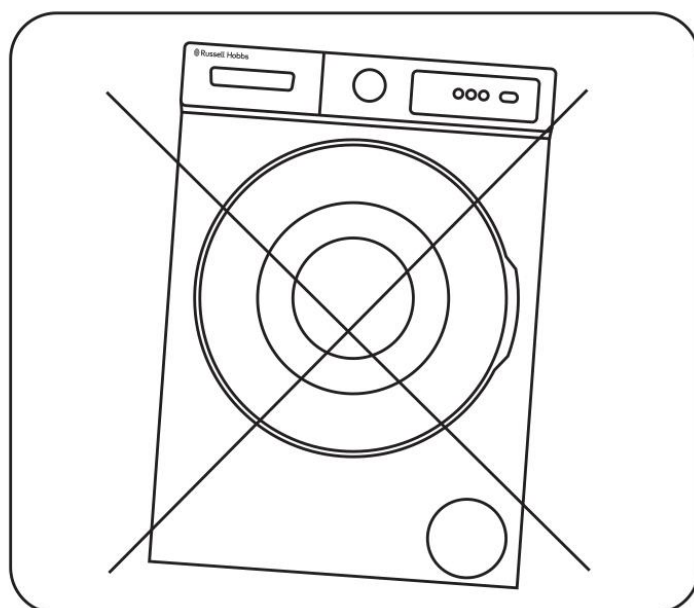
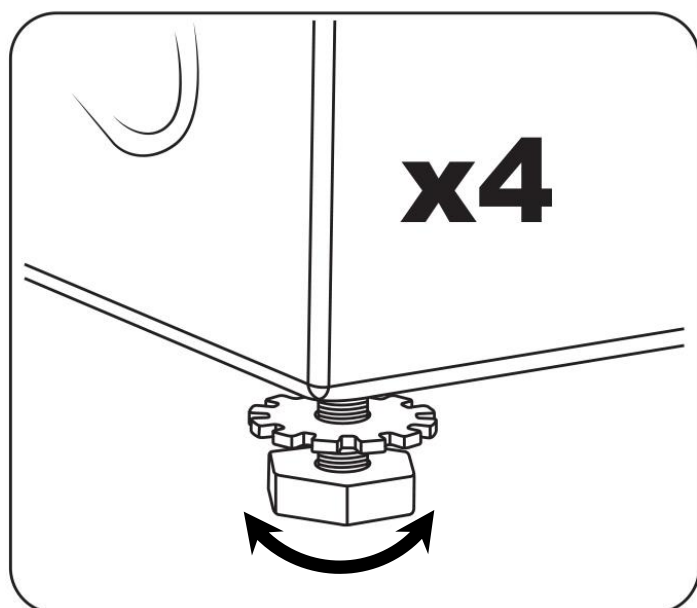

WARNING – we recommend a minimum of 2 people when moving or lifting the appliance.

WARNING – only level the appliance with the feet supplied. DO NOT use cardboard, wood or similar materials to level the appliance.

For optimal performance, your washing machine must be levelled, which will prevent deterioration of performance, damage to the appliance, and reduce noise.

We recommend the use of a spirit level to gauge the surface before adjusting any feet, by placing the appliance in its location and checking both the Forward and Side elevations.

Once you know the level of the appliance, slightly tilt the appliance at the required corner and using a 30mm spanner, rotate the desired foot in an anti-clockwise motion. Ensure levels are checked regularly during this stage.

INSTALLATION – LOCATION

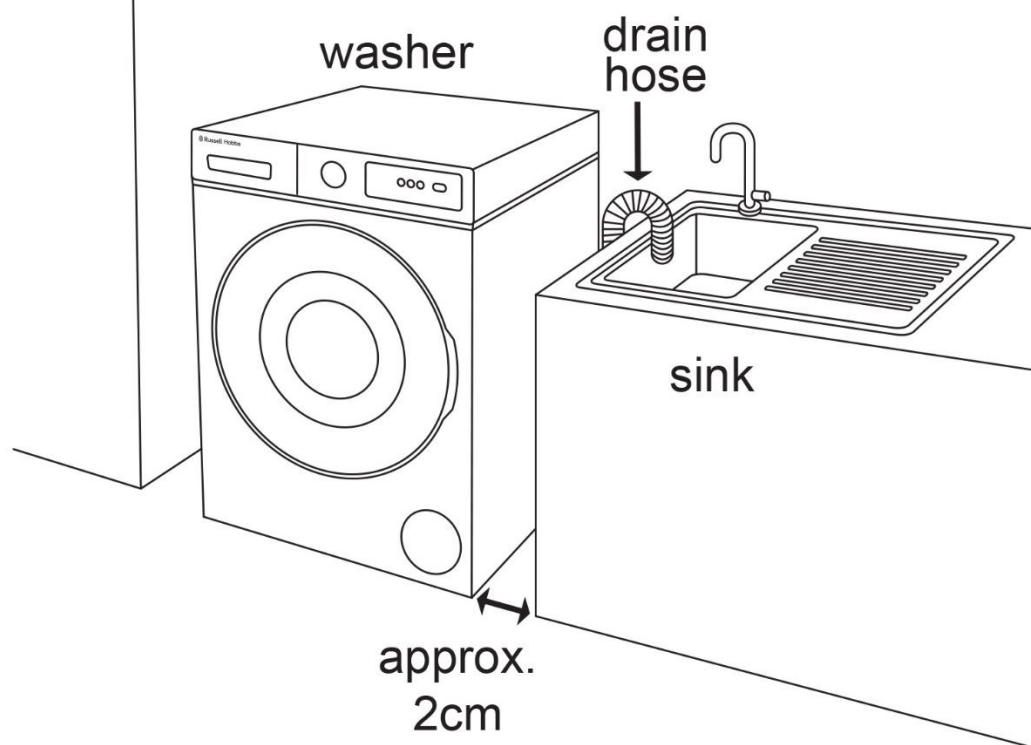

Before installation ensure you have all parts and accessories as highlighted in the instruction manual.

Ensure all transportation bolts have been removed.

Ensure appliance is to be installed in a position it will remain above 0°C (32°F), storage below this temperature will lead to irreparable damage.

DO NOT install on carpet, or any other surface which would reduce ventilation around the appliance.

ALWAYS leave adequate space around the appliance for ventilation (5cm on the sides, 10cm on the rear).

INSTALLATION – WATER INLET

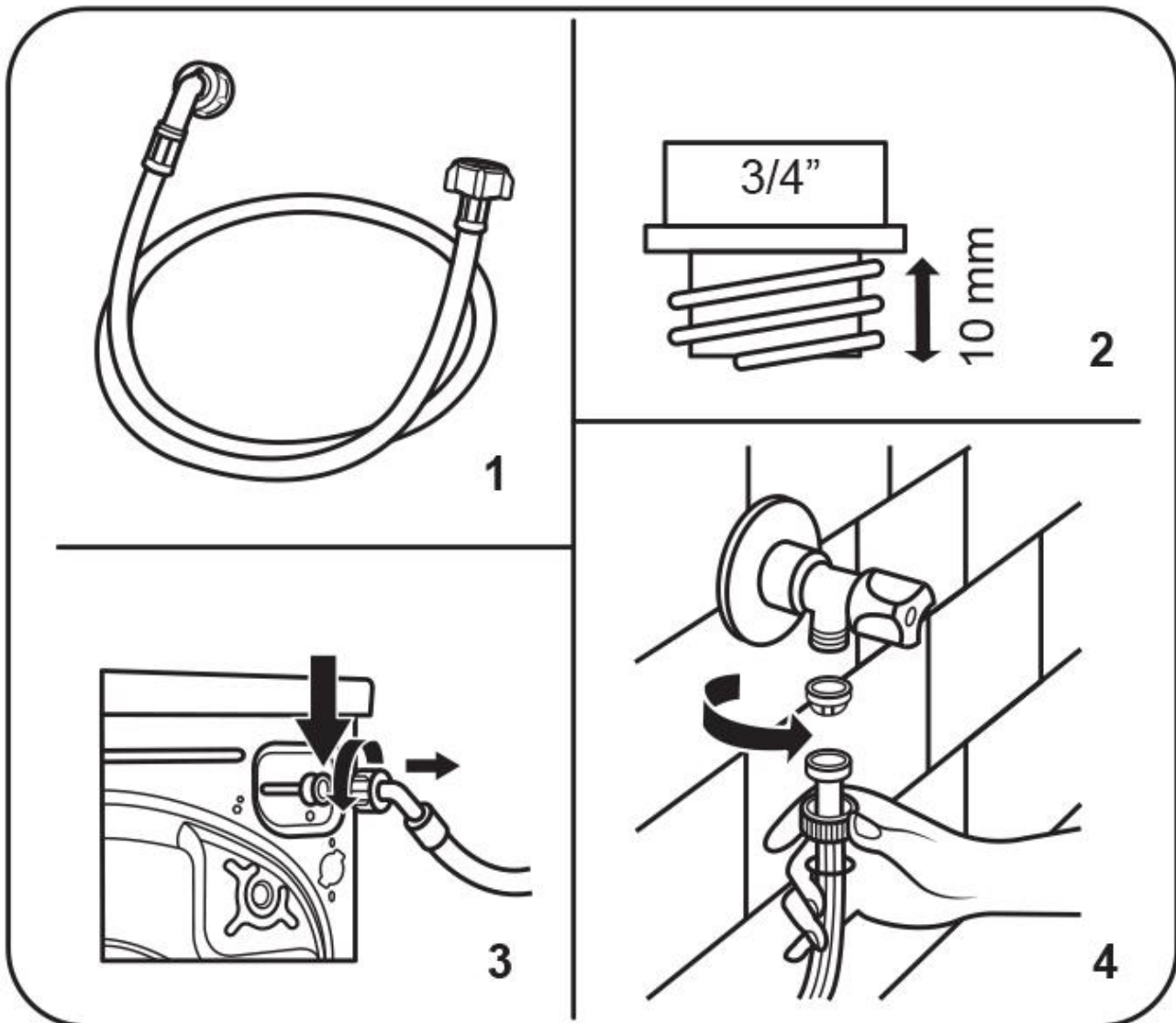

Your washing machine is COLD WATER fed only, **DO NOT** feed hot water into the machine.

ONLY use the included water inlet hose (Fig.1), or one sourced directly from the manufacturer.

Your appliance is supplied with a water seal. Ensure this is installed at the tap end (Fig.4)

Ensure the hose is free from kinks, folds and twists after installation.

INSTALLATION – WATER DISCHARGE

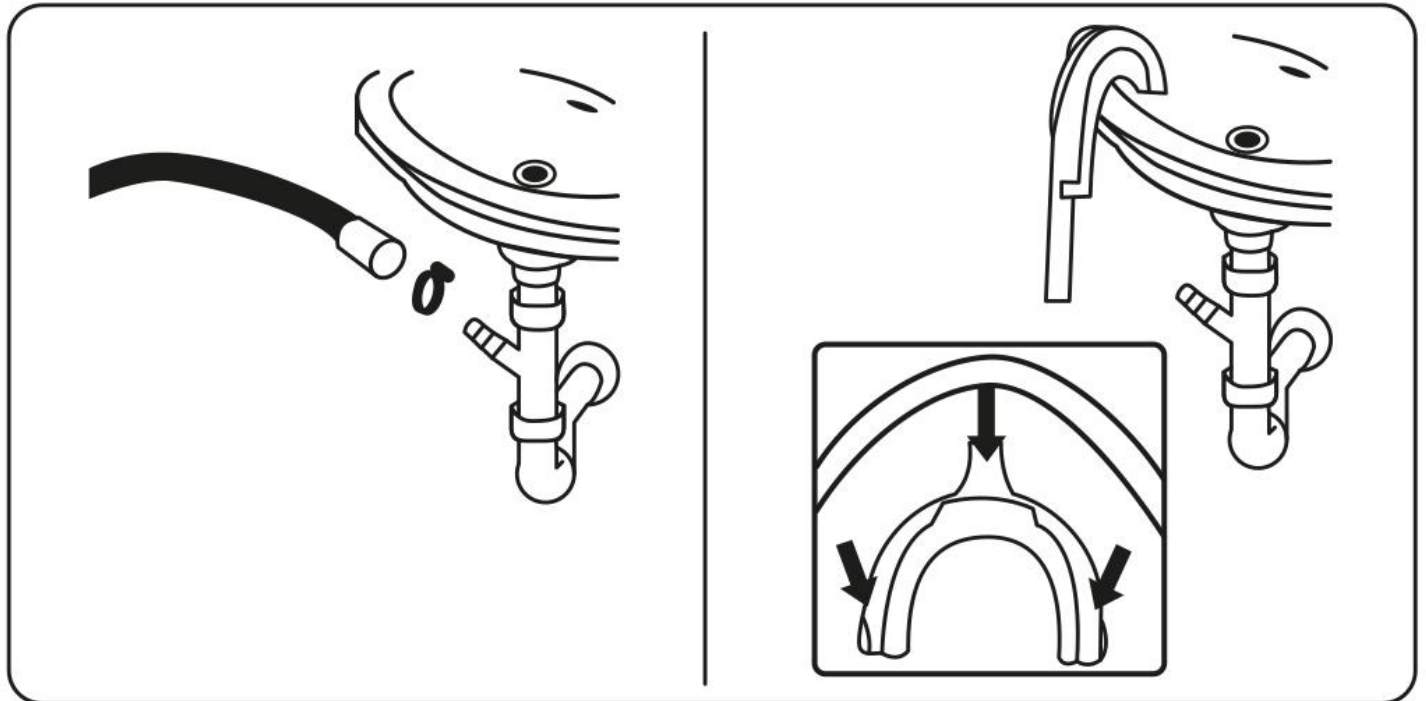

We recommend your washing machine is directly plumbed into your drainage system, or it can be discharged through an existing drain such as a sink.

The discharge pipe **MUST** be mounted a minimum of 60cm from the ground, and a maximum of 100cm.

Ensure the discharge pipe is free from kinks, folds and twists.

INSTALLATION – DETERGENT DRAWER

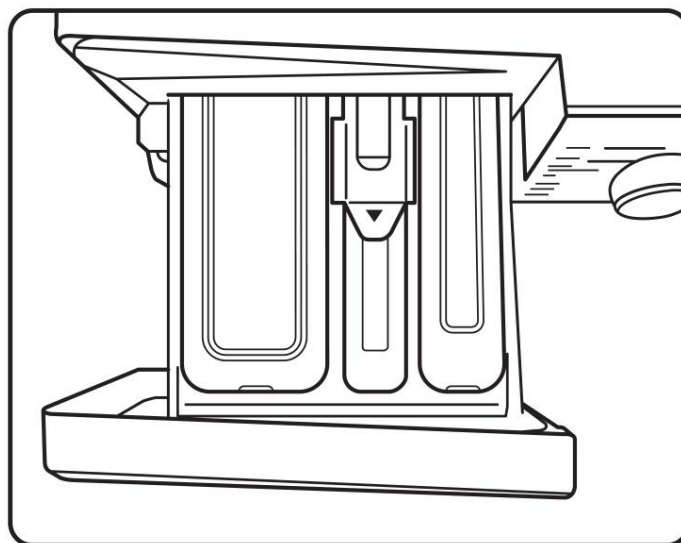
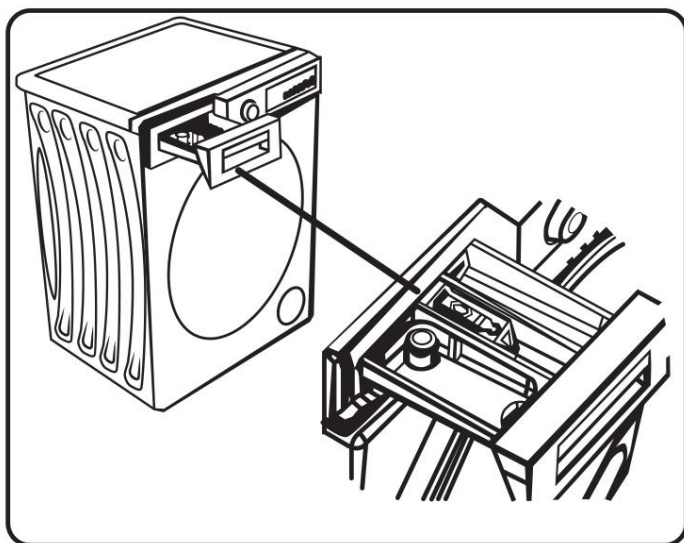

Only use substances in the detergent drawer such as Washing Powder, Fabric Softener, or specifically designed washing machine cleaning products. Only use detergents as directed by the supplier of the substance.

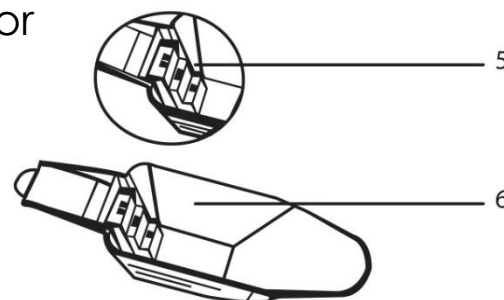

The detergent drawer is separated into 3 sections. Section II is used on all cycles, Section I is only used during pre-wash cycles,

and Section  is for fabric softener. Never fill past the Max line.

To remove the drawer for cleaning, press the blue clip (X) and gently pull the drawer from the machine.

To replace the drawer, push back in until it clicks. Do not force the drawer. If the drawer does not easily go in, press the blue clip whilst installing.

INSTALLATION – STACKING

This appliance can be installed and used in a stack with a dryer.

NEVER stack the washing machine on top of another appliance – the dryer must always be the top appliance.

ALWAYS check the dryer capacity is the same or below the capacity of the washing machine.

ALWAYS use a stacking kit/fixing kit when stacking appliances

ENSURE the floor underneath the stack can bear a weight of at least 150kg

ALWAYS review the below table to ensure sizes of the appliance are appropriate

Appropriate Installation Table for Washing Machine and Tumble Dryer					
Tumble Dryer (Depth)	Washing Machine				
	37-41 cm	42-45 cm	46-49 cm	50-56 cm	57-63 cm
52,5 cm	X	✓	✓	✓	✓
56 cm	X	X	✓	✓	✓
61 cm	X	X	X	✓	✓
64 cm	X	X	X	X	✓

DRAIN PUMP FILTER

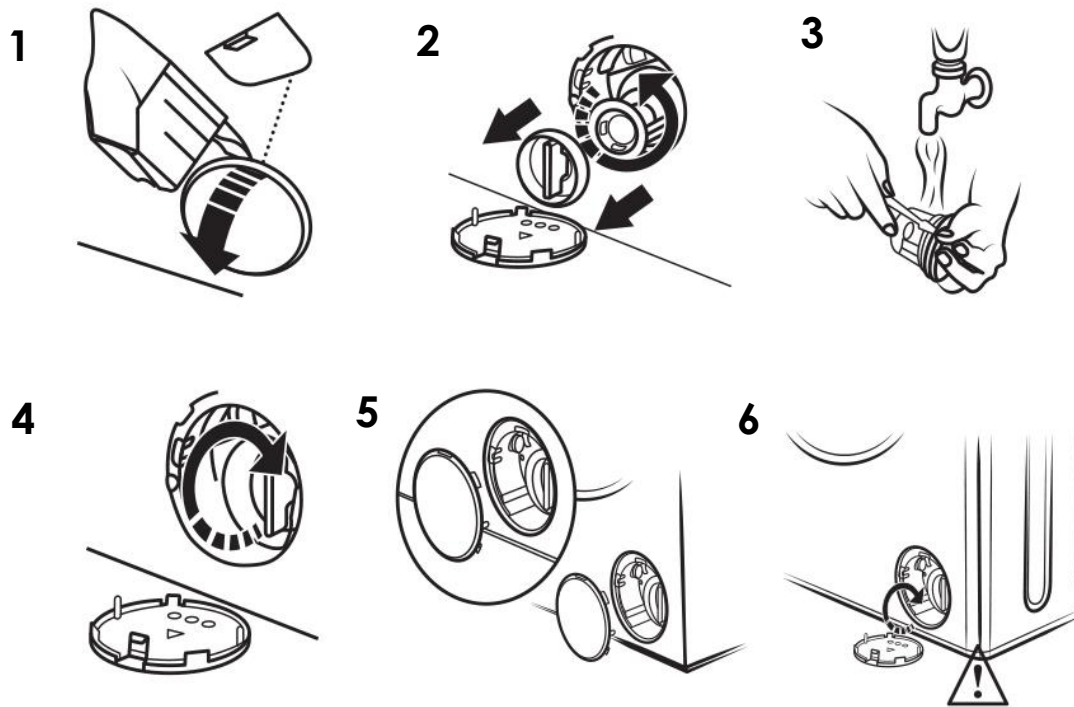

Regularly cleaning the pump filter prolongs the life of your pump and prevents lint from building up and damaging the appliance.

We recommend you clean the pump filter every 2 months.

Using the washing powder scoop (included), insert into the small notch and gently level off the cover.

Place a container such as a drain pan or towels under the filter before proceeding further.

Turn the filter anti-clockwise and remove the filter, water will drain out.

Remove any foreign materials and/or lint with a soft brush, then replace the filter by inserting and rotating clockwise.

Replace the filter cover by gently pushing into position.

FUNCTIONS & BUTTONS

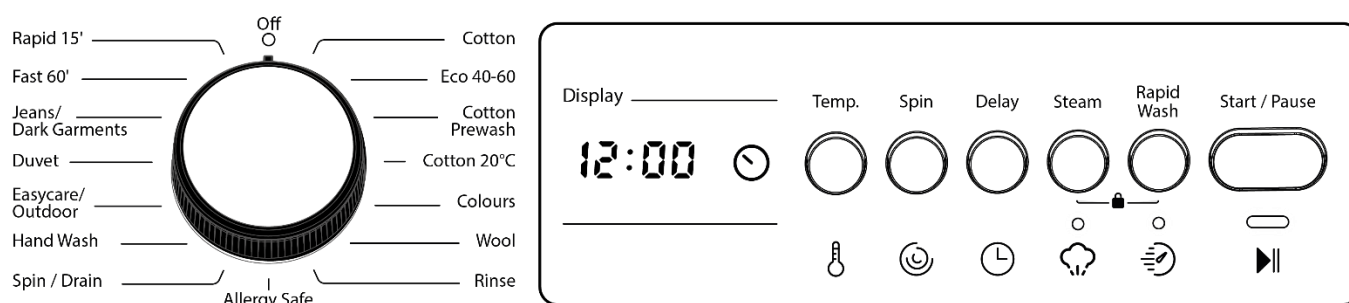

Child Lock

You can activate Child Lock on the appliance by simultaneously holding buttons 'Steam' and 'Rapid Wash' for at least 3 seconds. Once activated, 'CL' will flash on the display, and all functions will be locked.

- If the dial is moved into the 'Off' position, then turned to any programme, the appliance will continue the previously selected cycle.

To deactivate Child Lock, simultaneously hold the 'Steam' and 'Rapid Wash' buttons for at least 3 seconds until 'CL' disappears from the display.

Cancelling a Programme

To cancel a running programme at any time in a cycle, turn the programme dial to the 'OFF' position.

WARNING – your appliance may still have water inside. Before opening the door you **MUST** turn the programme dial to the 'SPIN/DRAIN' programme, which will begin the drainage cycle and cancel the previous programme.

In the event of a power cut, we recommend selecting 'SPIN/DRAIN' before running any other programme or opening the door.

IMPORTANT - FIRST TIME USE

Before using your machine for laundry, we recommend you perform a 'first-time' use cycle.

Add detergent such as a washing powder as highlighted in this instruction manual, but WITHOUT loading any laundry.

Select programme 'Eco 40/60', and adjust the temperature to 90°C, and the spin speed to 1200RPM.

Press the Start/Pause button, and allow the machine to run the whole cycle.

Once complete, your appliance is ready to use.

We recommend you always leave the door open after any kind of cycle to allow the appliance to fully dry and prevent build-up of mould.

OPERATION

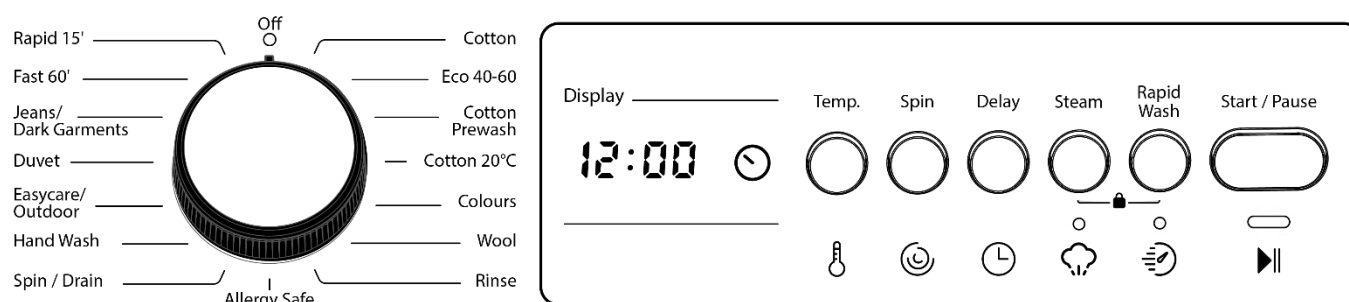

Turn on the appliance by selecting the appropriate programme using the dial. The marker on the dial indicates the selected programme. The selected programme time, will be displayed on the panel.

To adjust the temperature or the spin speed, press the function buttons to the right of the display to cycle through available temperatures and spin speeds depending on the programme selected, the Spin Speeds or Time will be displayed on the panel.

If you wish to delay the cycle, press the 'Delay' button and '1hr' will be displayed. You can delay between 1-23 hours.

To cancel the delay:

- If you have already pressed the Start/Pause button, press the Delay button once, and the clock symbol will clear.
- If you have NOT pressed the Start/Pause button, continue to press the Delay button until the clock symbol clears from the display.

Once you have selected the desired programme, temperature, spin speed, press the Start/Pause button to begin the cycle.

STEAM ASSIST

Your appliance has a Steam Assist function which penetrates and loosens the fibres in clothes, helping to remove creases to make ironing simple whilst also killing promoting hygiene.

Steam Assist can be set by selecting the desired wash program, and after the final cycle the steam function will operate for around 30 minutes.

When Steam Assist is selected, the below icon will be illuminated on the panel.

Note: Take care when removing clothes after a Steam Assist cycle as they may be warmer than after a regular cycle.



RAPID WASH

Rapid Wash can be used to reduce the length of time of the wash cycle for smaller loads, reducing time, energy and water usage. We recommend this setting is only used for half loads or lower, to ensure a satisfactory clean.

To activate 'Rapid Wash', select your desired wash cycle program, then press the 'Rapid Wash' button. The icon will illuminate on the panel, and the time will reduce.

Note: If your appliance detects a half load, it will activate rapid wash automatically.



IMPORTANT! CLEAN THE MACHINE

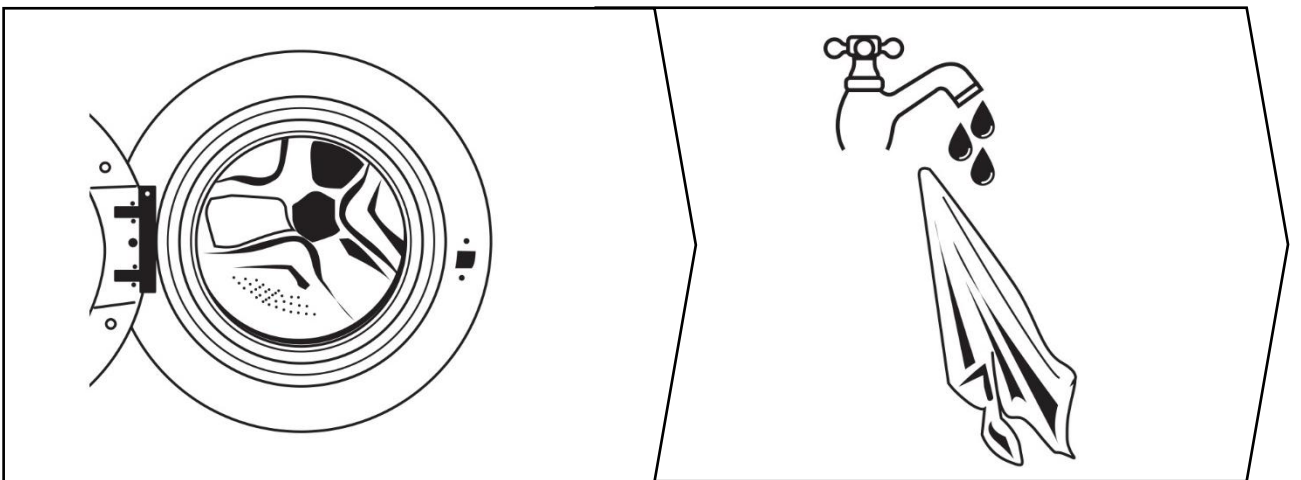
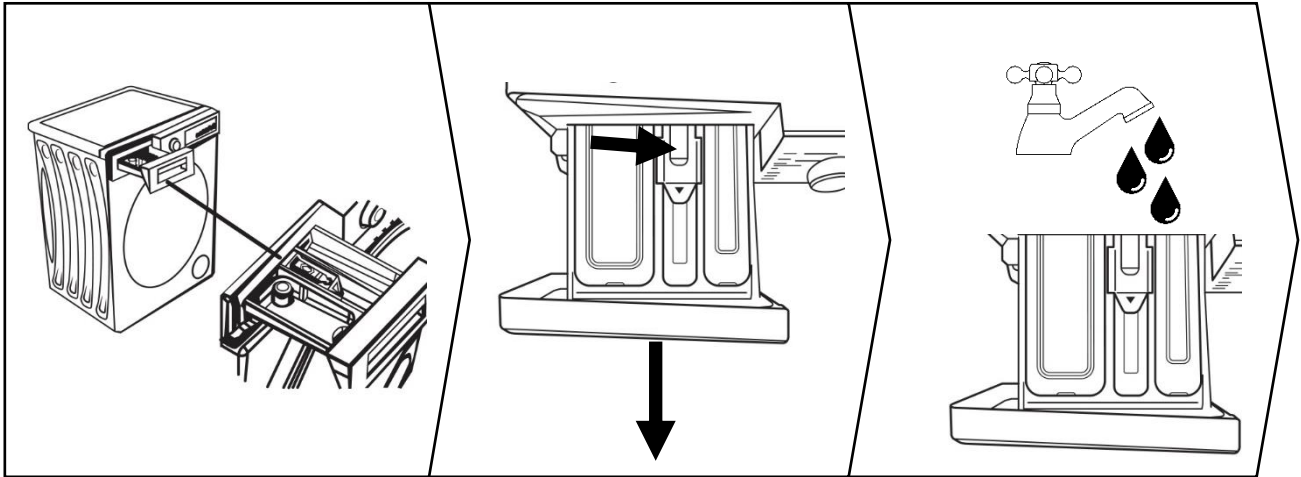

**ALWAYS LEAVE
DOOR ADJAR
AFTER CYCLE**

CLEAN DRAWER

Wash the drawer with hot water at least once a month.

CLEAN DRUM

Wipe the drum and seals with white vinegar.

1
MONTH

IMPORTANT! CLEAN THE MACHINE

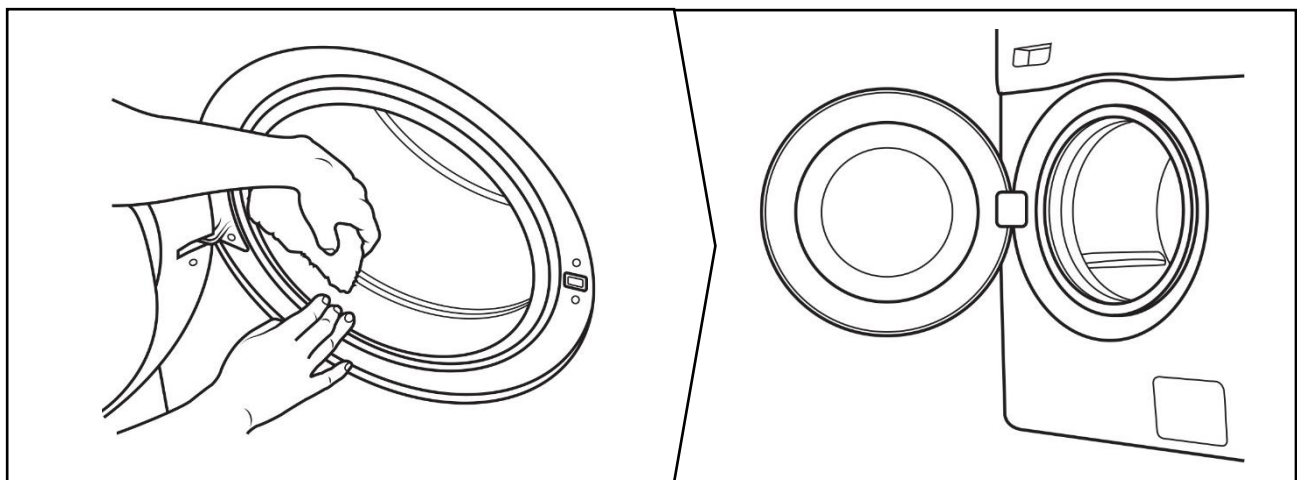
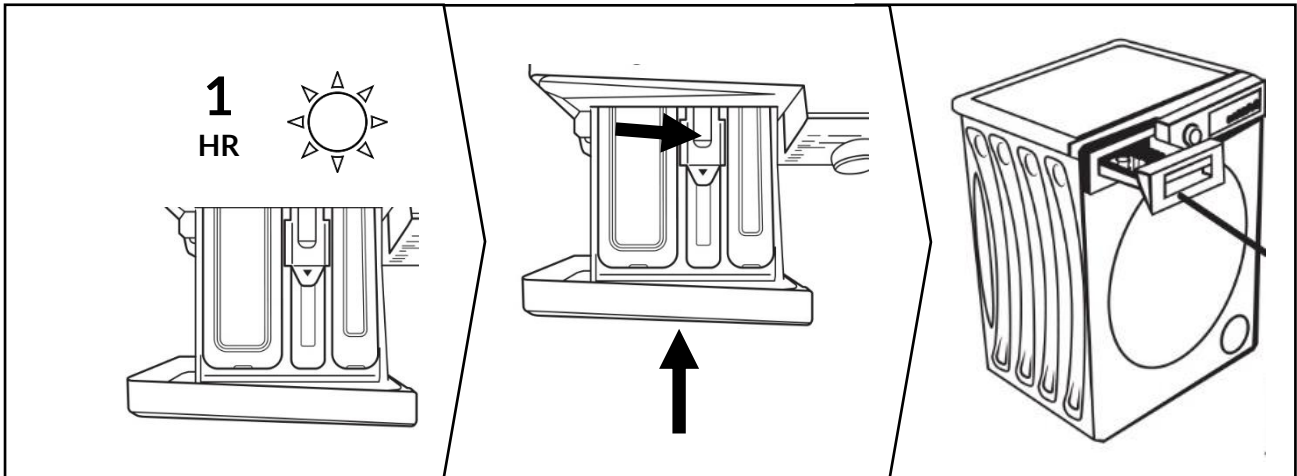

**ALWAYS LEAVE
DOOR ADJAR
AFTER CYCLE**

CLEAN DRAWER

Wash the drawer with hot water at least once a month.













CLEAN DRUM

Wipe the drum and seals with white vinegar.

**1
MONTH**

WASHING SYMBOLS & GARMENT CARE

The below are a selection of the most common care label symbols that may appear on your clothing. Always follow the instructions on the care labels to ensure that there is no damage or shrinkage caused by incorrect washing.

					
Wash at 30°	Wash at 40°	Machine Wash	Machine Wash Normal	Machine Wash Delicates	Hand Wash Only
					
Dry Clean Only	Do Not Dry Clean	Tumble Dryer Safe	Tumble Dry Low Heat	Tumble Dry Medium Heat	Do Not Tumble Dry

Important:

- Always separate light colours from dark colours.
- Always separate heavily soiled garments from normal washing, even if you would normally wash them together.
- Never overload the washing machine – the indicated maximum weight capacity of the washing machine is for **DRY** clothes however; there should always be air space and the door should shut easily without force.
- Always check the maximum load weight for specific programs listed in the program guide.

Below are some typical item weights (for guidance only):

Towel	200g
Bed Linen	500g
Pillow Case	200g
Underwear	100g
T-Shirt	150g
Jeans	650g

PROGRAMMES & TIMES

16 Series	Program Time (mins)*	Function
Eco 40-60	228	Lower power consumption whilst achieving normal cleaning results
Cotton	145	Normal wash cycle
Cotton prewash	164	Combined with pre-wash solution*, for very soiled laundry
Cotton 20°C	59	Lower temperature wash for less dirty, & unsoiled laundry
Colours	130	For less dirty & unsoiled laundry
Easy Care/Outdoor	135	Very dirty or synthetic laundry (e.g. Nylon)
Wool	48	Lower temperature wash to ensure your woollens don't lose their shape
Duvet	100	For all laundry types
Rinse	30	An additional rinse cycle to remove excess residue
Allergy Safe	212	Baby clothes
Spin/Drain	17	An extra spin to aid in drying your laundry
Hand wash/Delicate	90	For delicate and hand-wash only laundry
Rapid 15 min	15	Unsoiled laundry only
Fast 60' 60°C	60	A normal wash at 60°C but in a shorter time
Jeans	96	Dark items. Wash inside out. Caution: Dyes may run

**Programme duration may adjust based on weight of laundry, water temperature, ambient temperature, and selected function*

PROGRAM GUIDE

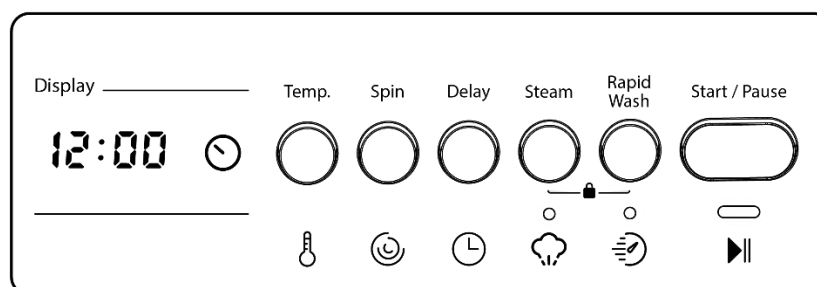
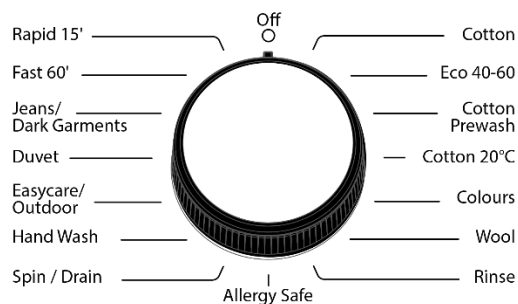

16 Series 9kg	Max Load **	Temp Range (°C)	Default RPM	Energy Cons. (kWh/cycle)	Water Cons. (l/cycle)
Cotton	9kg	40/ 60 /70/80/90	1400	2.35	71
Eco 40-60	9kg	40 /60	1400	0.91	56
Cotton prewash	9kg	30/40/50/ 60	1400	0.8	47
Cotton 20°C	4.5kg	Cold/ 20	1400	0.13	38
Colours	9.0kg	Cold/30/ 40	1400		
Easy Care/Outdoor	3.5kg	Cold/30/ 40	1200	0.91	72
Wool	2.5kg	Cold/ 30	800		
Duvet	3.5kg	Cold/30/ 40	800		
Rinse	9kg	Cold	1400		
Allergy Safe	4kg	Cold/30/40/50/ 60	800		
Spin/Drain	9kg	Cold	1400		
Hand wash/Delicate	2.5kg	Cold/ 30	800		
Rapid 15 min***	2kg	Cold/ 30	800		
Fast 60' 60°C	4kg	Cold/30/40/50/ 60	1400	1.11	35
Jeans	3.5kg	Cold/ 30	800		

**If washing towels, ensure only 50% Dry Load Capacity is used to prevent damage to the drum.

***Due to short cycle, use less detergent to prevent excess residue

Times and energy consumption will vary by load

PROBLEM SOLVING

Machine does not turn on	<ul style="list-style-type: none"> • Check it is plugged in • Check the plug socket operates correctly using another appliance • Check the fuse • Check the dial is not in the 'off' position
Machine does not take in water	<ul style="list-style-type: none"> • Check water inlet tap is on • Check for twists in the water inlet hose • Check inlet filter is not clogged • Check door is securely closed
Water does not drain	<ul style="list-style-type: none"> • Check the drain hose for twists • Clean the pump filter • Ensure drum is not over loaded
Excess vibrations	<ul style="list-style-type: none"> • Check transit bolts were removed upon installation • Adjust feet to level the appliance • Small load in machine • Check machine is not over loaded
Unsatisfactory results	<ul style="list-style-type: none"> • If in a hard water area, increase the amount of detergent • Ensure the machine is not overfilled, or too tightly packed
Water discharges from the machine immediately	<ul style="list-style-type: none"> • Drain hose is too low, ensure the drain hose is at a suitable height as advised in the installation instructions
No water visible during washing	<ul style="list-style-type: none"> • If laundry becomes wet, there is no fault • If laundry stays dry, contact customer services
Detergent residue left on laundry	<ul style="list-style-type: none"> • Perform an extra rinse cycle to remove or gently brush off after it has dried.
Spin cycle does not take place	<ul style="list-style-type: none"> • Unbalanced load sensor has been activated, the machine will attempt to balance the load itself and the spin cycle will begin once complete.
Door does not open	<ul style="list-style-type: none"> • Allow 2-5 minutes after the end of a cycle • Run a Spin/Drain cycle • Never force the door – contact customer services

ERROR CODES

Code	Fault	Solution
E01	Door not closed	Close the door until you hear a click. If the fault persists, turn off the appliance and contact customer services.
E02	Water pressure is low	Check the water feed is turned on. Check the mains supply is in operation by running a tap. If the problem persists, the appliance will switch off automatically. Contact customer services.
E03	Pump fault/pump filter clogged	Clean the pump filter. If the problem persists, contact customer services.
E04	Excess water detected	Machine will automatically drain the water. Once drained, turn off the tap and contact customer services.

TECHNICAL SPECIFICATION

RH914W116 W/B/AN	
Wattage	2200W
Operating Vol. / Freq. / Curr.	220-240V, 50Hz, 10A
Max. Dry Load Capacity	9kg
Spin (Max.)	1400RPM
Energy Efficiency Rating	A
Power consumption of Eco 40-60 Cycle at Full Load	1.030kWh
Power consumption of Eco 40-60 Cycle at Partial Load	0.370kWh
Water consumption of Eco 40-60 Cycle at Full Load	58.0L
Water consumption of Eco 40-60 Cycle at Partial Load	45.0L
Noise Level	77.0db
Dimensions (H)x(W)x(D)	9kg - 84.5 x 59.7 x 58.2cm
Inlet Hose Length	200cm
Drain Hose Length	160cm
Power Cord Length	150cm
Drum Volume	9kg – 59L
Optimal Ambient Temperature Range	15-25°C
Water Pressure (Min.)	0.1Mpa
Water Pressure (Max.)	1Mpa

Notes

IMPORTANT!

CLEAN DRAWER

Wash the drawer with hot water at least once a month.

CLEAN DRUM

Wipe the drum and seals with white vinegar.

1 MONTH



This product is guaranteed for 12 months from the date of the original purchase. If any defect arises due to faulty materials or workmanship, the faulty product must be returned to the place of purchase.



Made by Product Care Trading Limited under license from Spectrum Brands (UK) Limited. Product Care Trading Ltd, Unit 1, Green Bank Business Park, Swan Lane, Hindley Green, Wigan, WN2 4AY, United Kingdom

Product Care (Ireland) Ltd, Unit 3D North Point House, North Point Business Park, New Mallow Road, Cork, T23 AT2P, Ireland. Russell Hobbs is the registered trademark of Spectrum Brands (UK) Ltd.

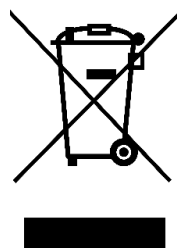

The 'wheellie bin' symbol is known as the 'Crossed-out wheellie bin Symbol'. When this symbol is marked on a product/batteries, it means that the product/batteries should not be disposed of with your general household waste. Only discard electrical/electronic/battery items in separate collection schemes, which cater for the recovery and recycling of materials contained within. Your co-operation is vital to ensure the success of these schemes and for the protection of the environment. For your nearest disposal facility, visit www.recycle-more.co.uk or ask in store for details.

SEDEX – Connecting businesses and their global suppliers to share ethical data and enabling improvement in ethical performance. Visit www.sedex.org.uk for further information.

We reserve the right, due to possible changes to design, to alter the instruction manual without prior notice.