

**REGISTER YOUR
APPLIANCE TODAY**

GUARANTEE

At Russell Hobbs, we take all our customer feedback seriously.

Feel free to contact our Product Care Team, on **0345 209 7461** who will be more than happy to assist you.

This product is guaranteed for 12 months from the date of the original purchase. If any defect arises due to faulty materials or workmanship, the faulty product must be returned to the place of purchase.

Refund or replacement is at the discretion of the retailer.

The following conditions apply:

- The product must be returned to the retailer with the original proof of purchase.
- The product must be installed and used in accordance with the instructions contained in this instruction guide and any other instructions for use which are supplied.
- It must be used for domestic purposes only and for its intended use.
- This guarantee does not cover wear and tear, damage, misuse or consumable parts.
- This does not affect your statutory rights.

RUSSELL HOBBS CONTACT DETAILS

Website: mda.russellhobbs.com

Telephone: 0345 209 7461

Address: Product Care, Green Bank Business Park,
Hindley Green, Wigan, WN2 4AY

Note your serial number below for future reference.



Image for illustration purposes only

REGISTER ONLINE

Visit our website to register your full parts and labour guarantee online.

mda.russellhobbs.com

REGISTER BY PHONE

Call our friendly Product Care team on the number below.

0345 209 7461

IMPORTANT SAFETY INSTRUCTIONS

- It is hazardous for anyone other than a competent person to carry out any service or repair operation that involves the removal of a cover which gives protection against exposure to electrical parts.
- Do not use with a damaged cord or plug. If the supply cord is damaged, it must be replaced by the manufacturer, its service agent or similarly qualified persons in order to avoid a hazard.
- This product is intended for household use only.
- Do not use outdoors.
- This appliance can be used by children aged from 8 years and above and persons with reduced physical, sensory or mental capabilities or lack of experience and knowledge if they have been given supervision or instruction concerning use of the appliance in a safe way and understand the hazards involved. Children should not play with the appliance. Cleaning and user maintenance should not be made by children without supervision.
- Do not operate this appliance for anything other than its intended use.
- Do not immerse whole unit in water or other liquids for cleaning.
- Unplug from outlet when not in use. Do not leave unattended while plugged in.
- Do not use if it has been dropped, damaged, left outdoors or dropped into water.
- Keep the appliance away from water; do not allow it to get wet. If unit is wet, do not plug unit into wall socket or turn unit on.
- Do not handle the appliance with wet hands.
- Do not pull or carry by cord, use cord as a handle, close door on cord, pull cord around sharp corners or edges, or expose cord to heated surfaces. Do not unplug by pulling on cord.
- To protect against electrical shock do not immerse cord, plug, or appliance in water or other liquid.
- Unplug from the mains outlet when not in use, before putting on and taking off parts, and before cleaning.
- Only use the unit when fully assembled.
- Never place your fingers or other objects into any part of the appliance. Be aware that loose clothing or hair may become trapped in the appliance if improperly used.
- Before use, ensure that all of the air vents of the appliance are clear and there is no restriction of air flow.

PARTS

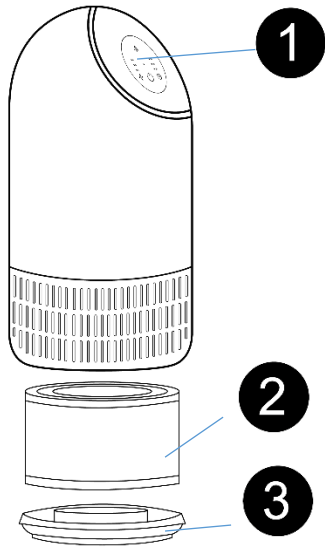

1. Control Panel
2. Filter
3. Locking Base

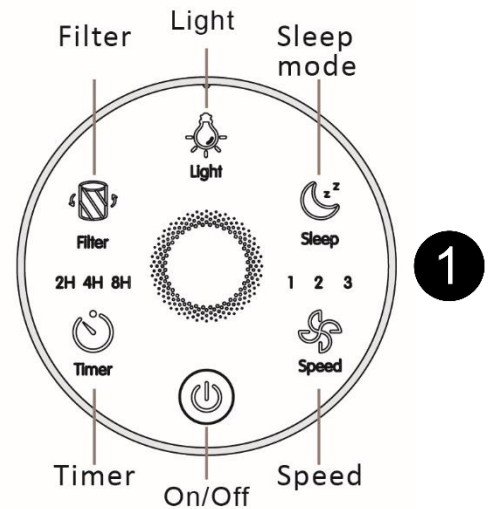

ASSEMBLY & FILTER INSTALLATION

Your air purifier comes pre-assembled in the box, but you will need to remove the protective sleeve from the filter prior to use.

To change the filter, remove the base of the air purifier.

Remove the old filter from the appliance.

Take the new filter out of any protective sleeves or packaging.

Install the new filter in the air purifier.

Refit the base to the air purifier.

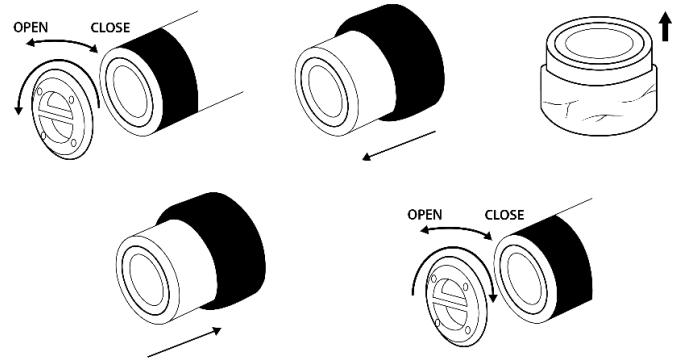

OPERATING INSTRUCTIONS

Press the Power button to switch on the Air Purifier. It will emit a beep and the machine will begin operating. The machine will either begin cycling through 7 colours, or resume the previous setting.



To turn off the appliance, press the Power button again and the lights & purifier will turn off.

During operation, press the timer button to select between 2 hours, 4 hours, 8 hours, or TIMER OFF.



OPERATING INSTRUCTIONS

When the air purifier is switched on, press the Fan Speed button to control the operating speed. The purifier operates in low, middle, and high speed settings.



The sleep function allows quiet operation, press the Sleep button during operation to activate. This reduces the noise and fan speed to a quieter level.



To set the colour, when the air purifier is on, the light will cycle through blue/cyan/green/yellow/ orange/red/purple. When you reach the desired colour for the night light, press the button once more. To turn the light off, press the NIGHT LIGHT button again.



Your air purifier has a memory function, so if the purifier is switched off/on it will resume the previously selected setting (light on/off/colour, speed).

Filter Change light description When indicator lights, it means that you should check the filter if it needs to be cleaned or replaced.
Note: The filters' lifetime is based on your house air quality and using time. Using the appliance in a humid environment will reduce the lifetime of the filter. The filter lifetime should be reset if it lights up. After replacing the filter, you need to reset the filter lifetime.



- 1). Plug in the air purifier and turn it on.
- 2). Press and hold for 3 seconds.
- 3). Release and the light will turn off, indicating that the reset is complete.

PROBLEM SOLVING

| | |
|------------------------------------|---|
| The air purifier doesn't switch on | <ul style="list-style-type: none">• Check the appliance is plugged in• Check the socket is switched on• Check another appliance in the socket• Unplug and check for any obvious signs of damage to cord or plug• If there is frost on the surface, allow to defrost• If recently used, allow to cool for 1 hour then try again |
| The air purifier is rattling | <ul style="list-style-type: none">• Check the filter and base is secured properly• Check there is nothing in contact with the air purifier |
| Unusual/Grinding sound | <ul style="list-style-type: none">• Immediately switch off and contact Customer Services |
| Light hasn't turned on | <ul style="list-style-type: none">• Check the appliance has switched on as first solution above• Press the Power Button• Hold the Power Button for 3 seconds.• Press the light button |
| The air smells or is dusty | <ul style="list-style-type: none">• Check the filter is properly installed• Ensure filter is clean and free from dust• The filter can be lightly brushed or vacuumed to remove dust. Do not wash with water• Replace filter with a new filter |

If you are still experiencing difficulties with the appliance please contact us **BEFORE** returning the appliance to the retailer it was purchased from:

Website: mda.russellhobbs.com

Telephone: 0345 209 7461

Address: Product Care, Green Bank Business Park,
Hindley Green, Wigan, WN2 4AY

IMPORTANT!

KEEP APPLIANCE CLEAN

Wipe the top with a damp cloth and brush any dust from the filter at least once every 3 months.

The appliance may require more frequent washing if in a dusty environment.

Replace the filter every 6 months.

3

MONTHS



This product is guaranteed for 12 months from the date of the original purchase. If any defect arises due to faulty materials or workmanship, the faulty product must be returned to the place of purchase.

By registering your product you will get an additional year guarantee free of charge. Additional cover can be purchased through the website.

REGISTER ONLINE

Visit our website to register your full parts and labour guarantee online.

mda.russellhobbs.com

REGISTER BY PHONE

Call our friendly Product Care team on the number below.

0345 209 7461



Russell Hobbs

Russell Hobbs is a registered trademark used under license from Spectrum Brands (UK) Ltd. Made under license by Product Care Trading Limited, Wigan, WN2 4AY/ PCT (NI) Ltd, Belfast, BT5 5AD

Russell Hobbs Support: call 0345 209 7461 or visit mda.russellhobbs.com

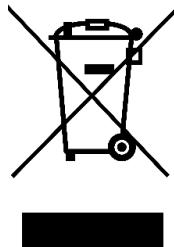
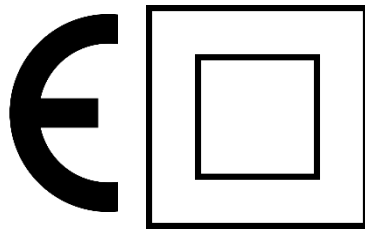

The 'wheelex bin' symbol is known as the 'Crossed-out wheelex bin Symbol'. When this symbol is marked on a product/batteries, it means that the product/batteries should not be disposed of with your general household waste. Only discard electrical/electronic/battery items in separate collection schemes, which cater for the recovery and recycling of materials contained within. Your co-operation is vital to ensure the success of these schemes and for the protection of the environment. For your nearest disposal facility, visit www.recycle-more.co.uk or ask in store for details.

SEDEX – Connecting businesses and their global suppliers to share ethical data and enabling improvement in ethical performance. Visit www.sedex.org.uk for further information.

We reserve the right, due to possible changes to design, to alter the instruction manual without prior notice.