

Domestic Electric Treadmill

READ AND SAVE THIS INSTRUCTION FOR FUTURE USE

ASSEMBLY INSTRUCTION

Contents

Product Instruction.....	01
Safety caution and warnings.....	02
Parameter and packing list.....	05
Instructions of Remote control.....	07
Exercise advice and plan.....	08
Instruction Manual.....	09
Maintenance.....	11
Common Malfunction and solution.....	13

Product Instructions

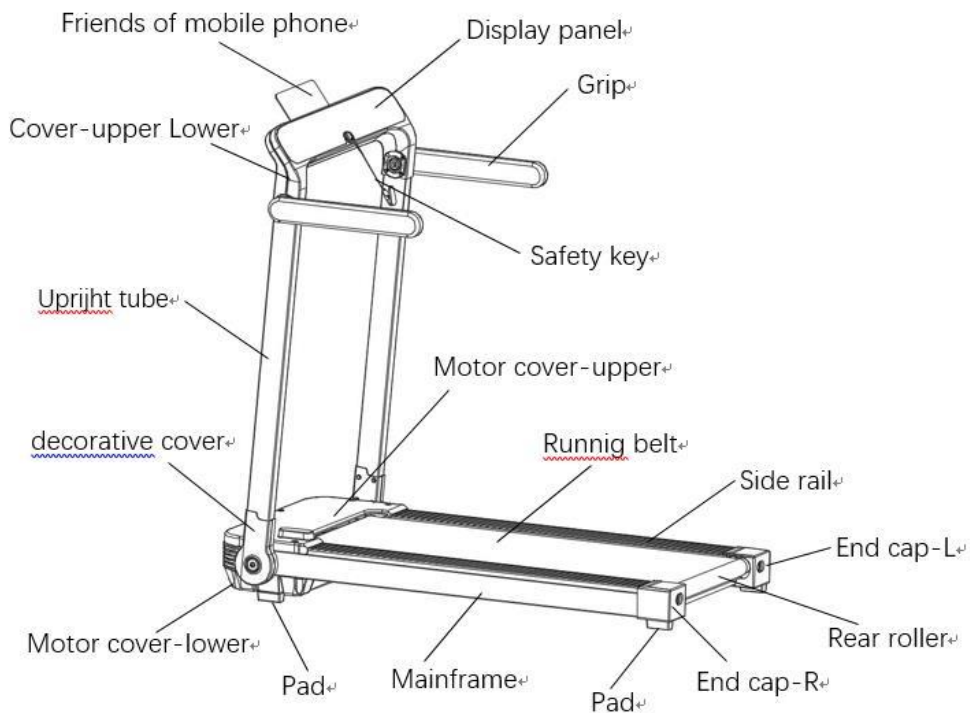

Safety cautions and warnings

Safety cautions and warnings

Caution ! Please read this manual carefully before using the product and take care following issues :

- * this treadmill should be used indoor, do not let this product be soaked and keep it away from water , do not put other things on the treadmill .
- *Please take the proper sports gear and do warming up before use the treadmill , do not use the treadmill on bare feet .
- *Power plug must be grounded and use dedicated circuit, do not share circuit with other electric equipment.
- *Kids should stay away from the treadmill to avoid unexpected situation .
- *Do not use the treadmill overload and over time, or the motor , control panel, bearing , running belt and board's life will be greatly shorten. Should do the regular maintenance to keep treadmill in good state .
- *Reduce dust and keep certain humidity indoor to prevent electronic and control devices from interference by static electricity .
- *Please turn off the treadmill after using .
- *Please make sure air circulation when you are using the treadmill
- *Please stop doing exercise if you feel uncomfortable and consult your doctor .
- *Please keep the silicone oil away from kid after using to avoid eating accident .

Warning : To avoid accident and injured , Please follow

issues below :

- *Please check your sports gear and make sure the zipper is lock
- *Do not wear clothes which is easy to be hooked by treadmill .
- *Do not put the power cord near the heat source .
- *Do not let kid play with or near the treadmill .
- *Must unplug the treadmill before moving it .
- *Never try to disassemble the product if you are unprofessional maintainer , or it will cause very bad consequence .

*The treadmill can only be used in 20A circuit .

*Only one person use it at one time , do not use it with two people and more .

*Please stop doing exercise if you feel dizzy , chest pain , nausea , or shortness of breath , and consult your fitness coach or doctor .

Warning ! Must Follow !

Please consult your doctor if you are under therapy or have any of following issues :

1. If you are suffering waist pain or hurt leg , waist or neck before , or have perceived obstacle to leg , waist , neck and hand (also include disc herniation , spondylolisthe-sis, cervical protrusion)

2. Deformed arthritis , rheumatism, gout

3. Osteoporosis or bone abnormality

4. Circulatory system disorder (heart disease , vascular disease , high blood pressure)

5. Respiratory organs disorder .

6. Implant cardiac pacemaker or electronic equipment .

7. Malignant tumor

8. Thrombosis , serious arterial lipoma , acute venous lipoma and other blood circulation disease or skin infections .

9. Perceived obstacle caused by diabetes .

10. Wounded on skin

11. Sick or fever (38°C or higher temperature)

12. Spine abnormality or bending

13. Pregnant women or women are in the menstrual period

14. Unhealthy and need rest

15. Obvious condition

16. For physical recovery purpose

17. Other bad feeling besides situations above , may cause unexpected condition

*Please stop doing exercise if you feel waist pain , dizzy , palpitations or other abnormal feeling , consult your fitness coach or doctor

*Do not let kid use this product . Kid should be kept away from this product , or it may cause unexpected hurting risk

*Please make sure no other people or pet around the product when taking , packing or sliding it

Forbidden !

- *Never use if you found the shell is broken and off (inside parts are exposed) or welding point is broken. Or it may cause unexpected condition.
- *Never jump on and off the product when you are using , it may cause falling and injured
- *Never store the product outdoors , near bath room , or any place where is damp
- *Never use or store the product under direct sunlight , near stove , electric blanket or other heating supply equipment , or it may cause electric shock or fire accident .
- *Never use the product when you found power cord or plug is broken or socket slack , or it may cause electric shock , short circuit or fire accident .
- *Never use the product with two or more people at the same time , keep others away when using this product ,or it may cause unexpected situation or falling accident .
- *Never use the product if user can not express self conscious or can not operate the product by himself / herself . Or it may cause unexpected situation .
- *Keep the product away from water or other liquid , especially the main base . Or it may cause electric shock or fire accident .
- *Never do intense exercise if you don't exercise usually . Do not use it after meal , fatigue , or other uncomfortable state , or it may be harm to your health .
- *This product is only for home use , never use it at school , stadium or other public place ,or it may cause unexpected situations .
- *Never use the product if you are eating or doing other behavior , also never use it after drinking , or it may cause accident or injured .
- *Never take your watch , bracelet , mobile phone and other valuable objects with you to avoid damage , also take off your keys and knife to avoid hurting yourself .
- *Please do check the power cord whether there is needle , garbage or other wet things before using to avoid electric shock , short circuit or fire accident .
- *Never touch the plug with wet hand to avoid electric shock .
- *Please turn the power switch to off position and unplug the plug if do not use it for a period to avoid electricity shock or fire accident caused by insulation deterioration .

Grounding explanation !

- * This product must be grounding , it can greatly reduce the risk of electricity shock when the product is in malfunction .
- *The plug of this product is grounding standard , please use local legal grounding power source

to connect the product .

Dangerous !

* It may cause electricity shock if the product is not grounding properly . please ask professional electrician to check if you are not sure whether the grounding is correct . Never modify the plug if it can not fit your power source , please ask professional electrician to install a proper power source .

*Never use transfer plug , this product must connect to power source with grounding function.

Parameter and Packing List

Parameters		
NO.	Parameter Name	Description
1	Input Voltage	AC220 V/ 50Hz
2	Motor Power	1.00HP
3	Speed Range	1-10km/h
4	Running	360*1050 mm

	Belt Area	
5	Maximum Load	110 kg
6	Expanded Dimension	1250*640*1190mm
7	N.W/G.W	29 / 33 Kg
8	Functions	Speed , Distance, Calorie. P1-P12/ H1-H3

Packing List

NO.	Name	Quantity
1	Base	1 pcs
2	Spare part Set	1 pcs

Spare Parts Set

NO.	Name	Quantity
1	Allen Wrench	1
2	Safety lock	1
3	Silicone Oil	1
4	Manual	1

Installation Instructions

Installation steps of standpipe :

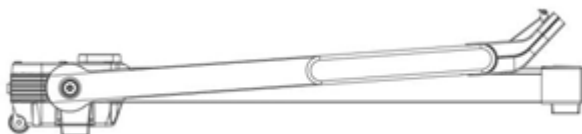

1 . place the product on the floor after taking out the product from packing box and take off the PE bag.

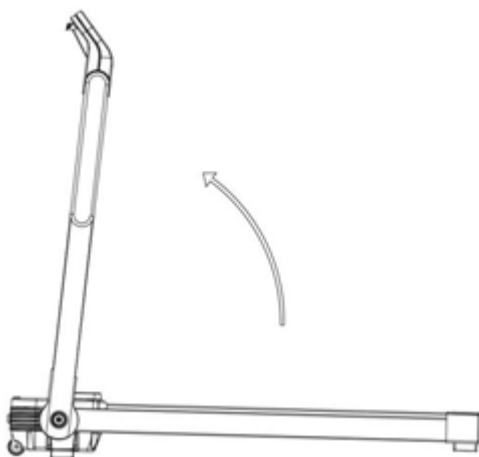

2. Raise the standpipe or Meter Assy and turn it to the direction as the arrow shows , until It stands still .

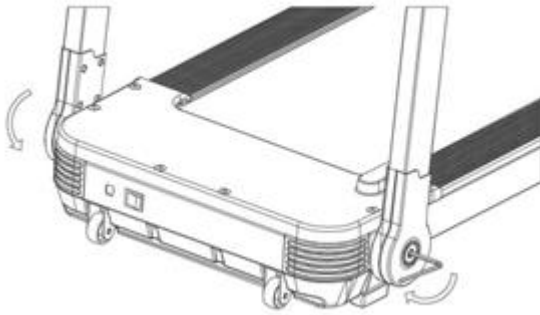

3. Take out the inner hexagon spanner(#6) from spare kit , put one end of the spanner into the screw hole of decorative cover ,tighten the screw in clockwise direction . the same installation method to the other end .(Loosen the screws in anticlockwise direction when dismantlement needed).

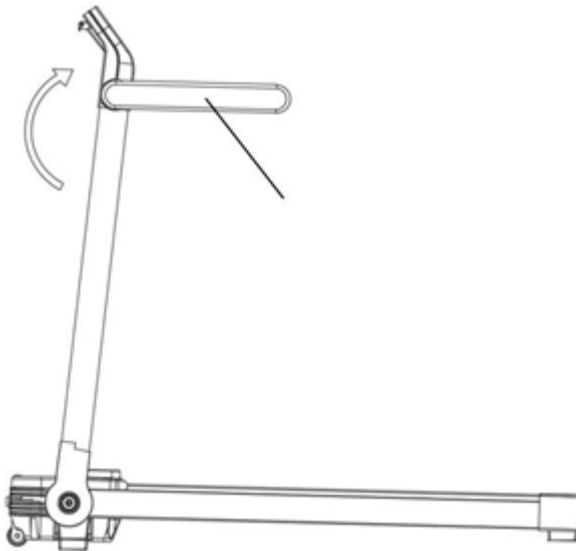

4. Keep the handrails in place as the arrow direction to adjust after the standpipe installation work finished .



5. Place the safety lock on yellow area of the panel.

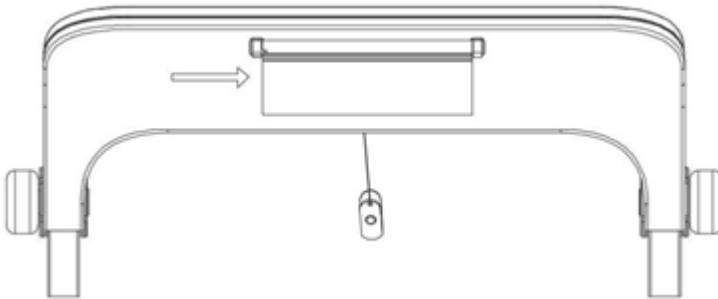

6. Turn the mobile holder upward after pushing the mobile holder to the right (as the arrow shows) until the holder is free from the slot.

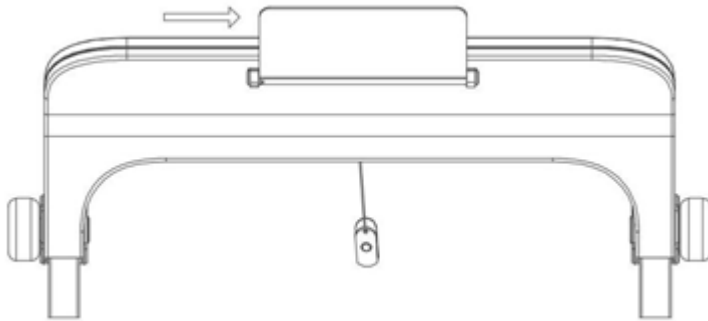

7. The illustration that guides how to use mobile holder correctly (push the holder to the right side until it is free from the slot and turn it downwards when dismantlement needed) .

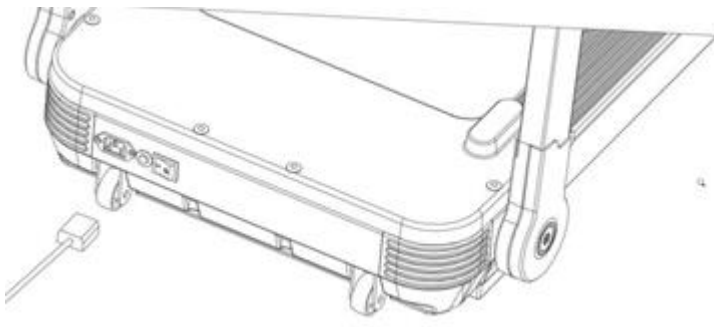

8. Keep the plug in the right socket , Orange light will be on when press the switch to “-” position.

Exercise advices and plan

***Warm up** do warm up exercise for 5-10 minutes before using this product

***Breath** do not hold your breath when you are using this product , try to breathe by nose and coordinate with your movement . you should stop if breath is too hasty .

***Exercise frequency** muscle should rest for 48 hours after exercising

***Intensity** it depends on different individuals , please increase intensity gradually , the fatigue can be cured under the situation .

***Diet** To protect the digestive system , please use this product in 1 hour after meal , also do not take any food in half hour after exercise , Try to not drink not too much water when exercise to reduce visceral burden .

***Stretching Exercises** No matter what speed you will run , stretching exercise is necessary firstly , it can improve muscle activity and reduce the risk of sports injured . So you can follow the guidance below after warming up , 5 times for each pose , and do it again after exercise .

1. Stretch down bend down relax shoulder and back then try to touch your feet ,3 times (Picture 1)

2. Stretch legs sit on a mat , stretch one leg and keep the other to stay balance then try to touch your toes of the straight leg , stay the Pose for 10-15 seconds then repeat to the other leg , 3 times (picture 2)

3. Stand and put your hands on the wall or table, then push your body down and stay 10-15 seconds , 3 times for each leg (picture 3)

4. Ankle joint stretch Stand and hold something to keep balance , then pull one ankle to your buttocks until you feel tense on leg muscle , stay 10-15 seconds , 3 times for each leg (picture 4)

5. Thigh stretch Sit and keep feet against , then pull feet to groin , stay 10-15 seconds and do it for 3 times (picture 5)



Instruction manual

*Brief introduction

It is a easy operating panel , it does not require complicated operation instructions :

Treadmill related : speed

Sports related :distance , calorie , time

Mode : manual mode , auto mode

Manual mode : free adjustable

Auto mode : with default data

*LED digital display

1. TIME
2. DISTANCE
3. SPEED
4. CALORIE

*Keys

Keys display as picture below :

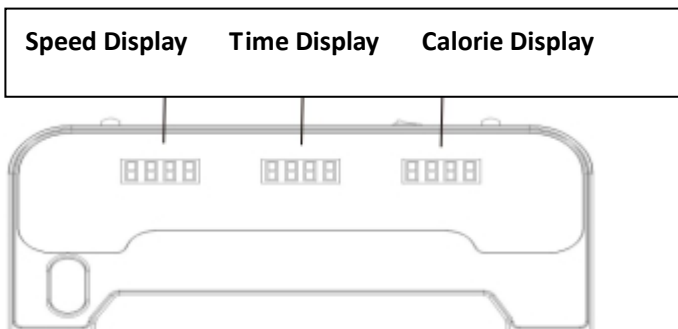

Parameter

1. Voltage : 220V/50HZ
2. Minimum speed : 1 km/h
3. Maximum speed : 10 km /h

4. Minimum working time : 5 minutes , Workout time : 99 minutes in auto mode
5. Minimum Calorie burning :20 Kcal ,Maximum Calorie burning : 999 Kcal in manual mode .

Safety warning

In any case , when safety lock removed , window will display : E07 (it indicates safety lock removed)

Mode

Auto mode :

Before workout , check the electric plug and power switch , Display window shows _ _ _ under standby state , Display window shows 0:00 when press the start key , Press start key again there will be a 3 seconds count down and display will show 1KM . then the display will shows speed , time , distance , calorie in loop . And you can adjust the speed by pressing speed+- key , the maximum speed is 10 km/h.

Manual mode :

Display window shows 0 :00 under standby state , display window will show P1.....P12 when press “p” key , Press “Time +- “ key can adjust workout time , Minimum workout time : 5 minutes , Maximum workout time : 99 minutes . After setting , system will enter Default state : 3 seconds count down to running .

Time Countdown (H1) continue press “P” key , display window will show “H1” enter time countdown workout schedule : Minimum workout time : 5 minutes , maximum workout time : 99 minutes .

Distance Countdown (H2) Continue press “P” key , display window will show ‘H2” enter distance countdown workout schedule : Maximum Distance : 99 km

Calorie Burning Countdown (H3) Continue press “P” key , display window will show “ H3 “ enter Calorie countdown workout schedule : Minimum Kcal burning :20 Kcal , Maximum Kcal burning : 990 Kcal

Maintenance

Lubricating

The running belt must be lubricated with the specialized silicone oil after using for a period.

1. Suggestions

Workout time : less than 3 hours weekly , lubricate it every 5 months

Workout time : 4-7 hours weekly , lubricate it every 2 months

Workout time : over 7 hours weekly , lubricate it monthly

Notice : do not over lubricating , reasonable lubricating can prolong life of treadmill .

2. Methods of lubricating

To check whether your treadmill needs lubricating , you can hold the running belt and put the other hand to touch the bottom center of running belt , if you can feel the wet silicone oil that means it does not need lubricating . if you feel the running belt is very dry that means your treadmill needs a lubricating .

A : How to lubricating (as picture)

B: stop and fold the treadmill

C: Raise the running belt on the base , then try to put the silicone oil pot under the running belt and smear the silicone oil on the belt and both sides of the treadmill , then set 1 Km/h to make sure silicone oil lubricates well , you can step the running belt from left to right to improve the lubricating effect .

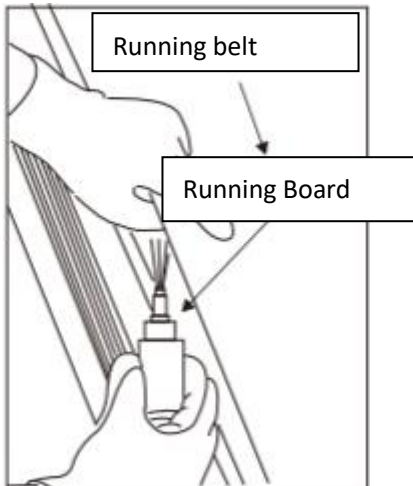

3. Elastic tendency adjustment of running belt

Every treadmill would set the elastic tendency before it leaves factory and after assembly , but it will become loose after using for a period .

Just like it will stuck or slide sometimes , you can turn the adjusting bolt in clockwise direction , semi-circle a time (left and right at the same time) to adjust the running belt . Don't make it too loose or too tight , or the running belt will slide or make motor over load .

4. Running belt deviating .

There are some factors causes this situation :

A: the treadmill is not placed in flat floor

B: User does not step on the centre of the running belt

Just set the treadmill flat and run idly will solve the issue : A.

If the deviating still exists , you can adjust it with 6mm Allen wrench in a quarter turn .Deviating is out of warranty . User can maintain it by the instructions below : Please fix it as soon as you find the problem or it will break the running belt .



If deviating turns to right , then turn

the left screw in counterclockwise direction, turn the right screw in clockwise direction



If deviating turns to left , then turn

the left screw in clockwise direction, turn the right screw in counterclockwise direction

A: Turn the screw in clockwise direction with Allen wrench

B: Adjust the intensity , when the running belt will not slide during load is ok (clean the debris between belt ditch and belt wheels)

Common malfunction and solution

Malfunction	Cause	Solution
Treadmill can not work	unplug	Plug the power cord
	Single wire or power supply broken	Check signal wire
	Switch off	Switch on
Running belt does not move smoothly	Not enough lubricating	Lubricate with silicone oil
	Running belt is too tight	Adjust the intensity of the running belt
E01	Communication failure	Check the lines if connected properly
E02	Motor line fall off	Check motor lines if loosen or fall off
E05	Overcurrent protection	Restart the machine
E07	Safety lock fall off	Place the lock on the yellow area of the panel



001-877-644-9366
customerservice@aosom.com



001-855-537-6088
customerservice@aosom.ca



0044-800-240-4004
enquiries@mhstar.co.uk



0049-(0)40-88307530
service@aosom.de



0033-1-84166106
contact@aosom.fr



0034-931294512
atencioncliente@aosom.es



0039-0249471447
clienti@aosom.it