

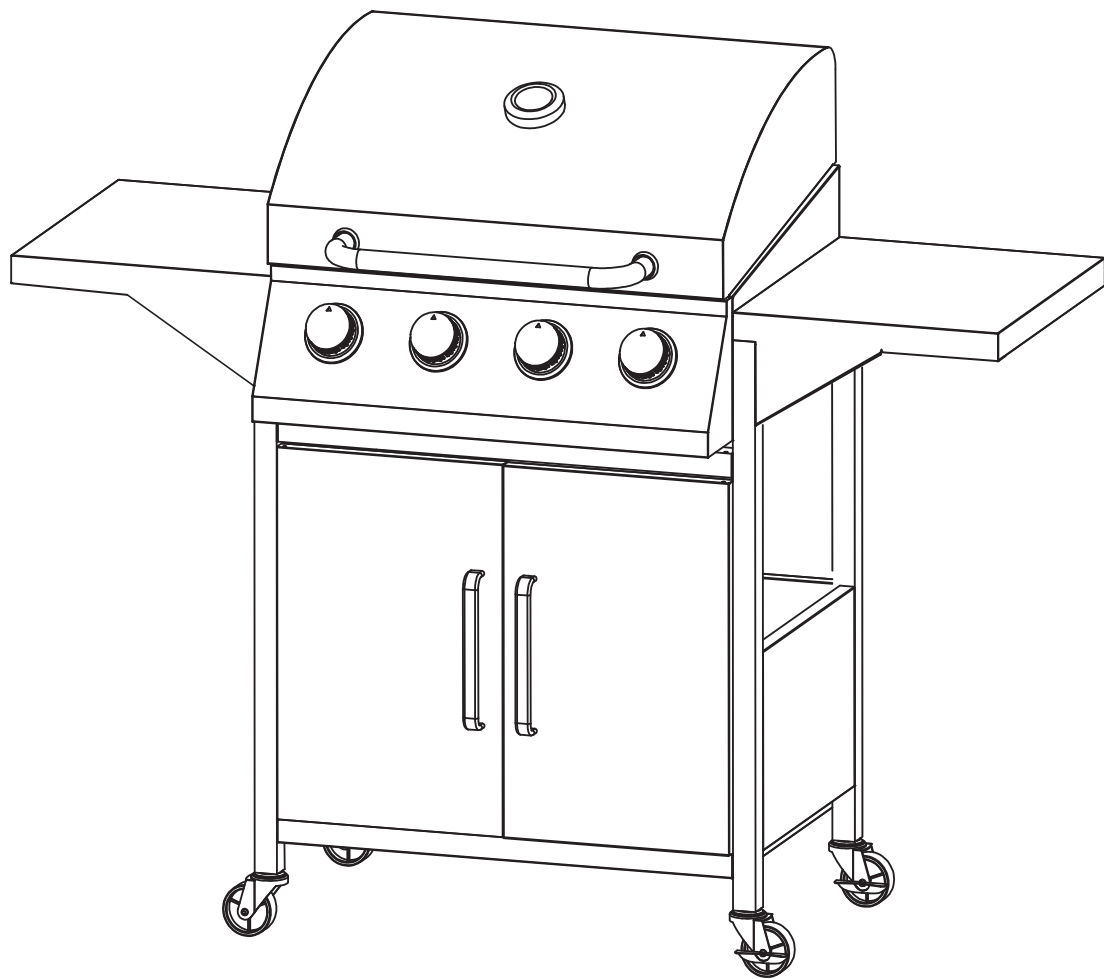

IN231000448V02_UK

846-103V71

YF-01JY04-A



IMPORTANT, RETAIN FOR FUTURE REFERENCE: READ CAREFULLY

ASSEMBLY & INSTRUCTION MANUAL

SAFETY INSTRUCTIONS

1. Read the instruction manual carefully before use and keep it for future reference. Failure to comply with the instructions can result in death, serious injury or property damage.
2. For outdoor use ONLY! Do not use indoors.
3. Do not use below ground level.
4. The accessible parts can get very hot. Keep small children, elderly people and animals away from the gas grill. Grill glove is advised.
5. Do not move the product while it is alight.
6. Turn off the gas supply at the gas cylinder when the grill is not in use or after use.
7. Any modification of the product, misuse or failure to follow the instructions may be dangerous and will void the warranty.
8. Check your gas grill annually for leaks. Check whether the hose connections are tight and leak test them each time you reconnect the gas cylinder.
9. Do not use the gas grill within 1 meter of combustible materials or surfaces.
10. LP gas cylinders should not be placed directly underneath the grill.
11. Open the hood of the grill before lighting.
12. Do not leave the grill unattended when it is lit.
13. Be careful when opening the hood, as the hot steam inside is released upon opening.
14. Do not cover the grill until it has completely cooled down.
15. Do not use aerosols near the grill.
16. Do not store or use petrol or other flammable vapours or liquids in the vicinity of this gas grill or any other appliance.
17. If you smell gas, turn off the gas supply at the gas cylinder; extinguish any open flame; open the hood. If still have it, stop use.

WARINING

- Read the instructions before using the appliance. Follow the steps in the order specified and please observe the safety warnings.
- Failure to observe these instructions can affect or damage the device and other objects and lead to personal injury.
- These instructions are part of the product. They should always be stored with the product and should be passed on to each subsequent user.
- Great care has been taken during production to remove sharp edges but you should handle all components with care to avoid possible injury.
- To avoid injury and damage to property, be sure to follow all warnings and instructions carefully, before every use.
- **NEVER LEAVE A LIT BARBECUE UNATTENDED.**
- If ever in doubt, consult a qualified gas engineer before use.
- As an extra precaution **WHEN LIGHTING FOR THE FIRST TIME ALWAYS TAKE EXTRA CARE.** Keep your head and arms from hanging over the BBQ cooking surface.
- **ALWAYS** make sure the barbecue appliance is completely cool before applying covers.
- In construction of this BBQ use all and only the components provided. Do not modify BBQ or parts. Any modification of the appliance may be dangerous.

- **KEEP THIS APPLIANCE CLEAN** (follow instruction) - To help avoid fat flash fires/ flare ups and therefore possible injury or damage to property, it is vital that this appliance is clean when used.
- Stand your barbecue on a safe. level surface, well away from flammable items such as wooden fences or over-hanging tree branches.
- Protect from the elements and damp.
- Keep children and pets away.
- An adult should always be in charge of the BBQ. **NEVER** leave a hot barbecue unattended.
- Always make sure the barbecue is fully extinguished and completely cool before moving, applying covers (not included) **OR** storing away.
- Do not use indoors - For outdoor use only.
- **CAUTION! NEVER STORE** a barbecue indoors unless it is fully cooled and gas supply cylinder is disconnected.
- Do not use the BBQ on a surface that may be damaged by excessive heat.
- This is a gas appliance. Do not use any other type of fuel / accelerants or lava rock.



- **DO NOT** lean over the barbecue when igniting the gas flame.
- Close the valve on the gas bottle after each use. (Refer to regulator instruction). Also turn off the control knobs (Turn knob fully clockwise).
- Never leave the hot barbecue unattended. If the flame extinguishes, relight immediately or cut off the supply from the gas bottle.
- When connecting the gas bottle, ensure that there are no ignition sources within a 5m radius.

Take special care not to light any naked flames, do not smoke or switch on electric appliance (devices, lights, door bells), etc (spark over possible).

- Before each use, check to ensure that all connections through which gas is supplied are sealed and intact.
- If necessary, ensure that you replace the hose to meet with national requirements. (Always use hose-clips to secure the hose to the regulator and BBQ).
- If the connections for the gas supply are porous or faulty, the barbecue must not be used. This also applies, for example, to hose or fittings that may become blocked, as this can lead to a dangerous flashback.
- Liquid gas is heavier than oxygen. Therefore it settles on the ground and displaces the oxygen at that level.
- Possible consequences:
- Suffocation resulting from the lack of oxygen if the gas concentration is allowed to rise sufficiently.
- Do not use the barbecue unless it's completely assembled and all parts are securely fastened and tightened.
- Do not leave a lit barbecue unattended, especially keep children and pets away from barbecue at all time.
- Do not move the appliance during use.
- Never cover the entire cooking area.
- Never obstruct the ventilation opening of the container compartment.
- Do not use power tools to construct this product.
- Do not over tighten screws or bolts.
- Do not tighten screws until fully assembled.
- Do not sit or stand on the product.
- Do not use this product if parts are missing, damaged or worn.
- Never use scourers, abrasive or chemical cleaners.
- Time to assemble: around 1 hour.

Do's

- **KEEP THIS APPLIANCE CLEAN** (follow instruction) - To help avoid fat flash fires/ flare ups and therefore possible injury or damage to property, it is vital that this appliance is clean when used.
- Stand your barbecue on a safe. level surface, well away from flammable items such as wooden fences or over-hanging tree branches.
- Protect from the elements and damp.
- Keep children and pets away.
- An adult should always be in charge of the BBQ. **NEVER** leave a hot barbecue unattended.
- Always make sure the barbecue is fully extinguished and completely cool before moving, applying covers (not included) OR storing away.

Don'ts

- Do not use indoors - For outdoor use only.
- **CAUTION! NEVER STORE** a barbecue indoors unless it is fully cooled and gas supply cylinder is

disconnected.

- Do not use the BBQ on a surface that may be damaged by excessive heat.
- This is a gas appliance. Do not use any other type of fuel / accelerants or lava rock.



CAUTION

- KEEP OUT OF REACH OF CHILDREN and PETS DURING and AFTER USE.
- Do not store or use petrol or other flammable vapor or liquid in the vicinity.
- This appliance will become very hot during operation - always wear suitably protective heat proof gloves during use.
- **WARNING:** Accessible parts may be very hot. Keep Young children away.
- Turn off the gas supply at the gas container after use.
- **ALWAYS** close and disconnect from main gas supply cylinder after use and for storage.
- **DO NOT MOVE THE APPLIANCE DURING USE.**



DANGER!

- If you smell gas:
 1. Shut off gas supply to appliance.
 2. Extinguish any open flame, avoid using any electrical appliance.
 3. Open lid and ventilate the area.
 4. Check gas connections with soap solution.
 5. If odor still exists, immediately contact your gas supplier or fire department.

ASSEMBLY

- Do not use this product if parts are missing, damaged or worn.
- Never use scourers, abrasive or chemical cleaners.
- When you are ready to start, make sure that you have the right tools, plenty of space and a clean, dry area for assembly.
- Check the pack and make sure you have all the parts listed.
- During assembly children should be kept away from the product due to possible risk of injury.
- Ensure that this product is fully assembled as illustrated before use.
- Check all screws and bolts are tightened regularly.
- Tools not included.
- Please refer to the parts list and assembly diagram as necessary. Assembly of the barbecue involves many large components; it is advisable to have two people assemble the unit.
- Please use protective gloves when assembling this product.
- To avoid losing any small component or hardware, assemble your product on a hard level surface that does not have cracks or openings.
- To avoid damage to soft floor or carpet, do not assemble or move the appliance on soft floor or carpet.
- Follow all steps in order to properly assemble your product.
- Make sure all the plastic protection is removed before assembling.
- Do not force parts together as this can result personal injury or damage to the product.
- When applicable , tighten all hardware connections by hand first, once the step is completed, go back and fully tighten all hardware.

- Please read these instructions carefully before assembly and use.

Caution: Whilst every effort has made in manufacture of your barbecue to remove sharp edge, you should handle all components with care to avoid accidental injury.

Safety and Care Advice

Important! Please read this instructions fully before using the appliance

- Retain these instructions for future reference.
- Use outdoors only.
- Do not use the barbecue or store gas bottles below ground level. LP gas is heavier than air so if a leak occurs the gas will collect at a low level and could ignite in the presence of a flame or spark.
- For use with LPG bottled gas only. A suitable regulator must be used for butane, propane or mixes.
- Remove plastic wrap from any part before lighting.
- Do not use within 1m of any flammable structure or surface. Do not use under any combustible surface.
- LP gas cylinders should never be placed directly underneath the barbecue.
- LP gas cylinders should never be stored or used laid on their side, in the horizontal position. A leak would be very serious and liquid could enter the gas line with serious result.
- Never store gas bottles indoors.
- Do not move the appliance during use.
- Open the barbecue hood before lighting.
- Do not move the barbecue until it has completely cooled after use.
- This barbecue must not be left unattended when lit.
- The hood handle can become very hot. Grip only the centre of the handle. Always use oven gloves when cooking or carrying out any adjustments to the barbecue.
- Use purpose designed barbecue tools with long and heat resistant handles.
- Use caution when opening the hood, as hot steam inside is released upon opening.
- Warning: accessible parts may be very hot. Keep young children away.
- Turn off the gas supply at the gas cylinder after use.
- Never cover a barbecue until it has completely cooled.
- Use this barbecue only on a stable and flat surface.
- Before use this barbecue , perform a leak test. This is the only safe and sure way to detect any gas leaking from joints and connections of the barbecue after assembly.
- Leak test annually, and whenever the gas bottle is removed or replaced.
- Do not store flammable materials near this barbecue.
- Do not use aerosols near this barbecue.
- Failure to follow the manual's instructions could result in serious injury or damage.
- Do not modify the appliance. Modification of this barbecue may be dangerous, is not permitted and will nullify any warranty.
- This appliance must be kept away from flammable materials during use.
- All the parts sealed by the manufacturer or his agent shall not be manipulated by the user.
- If you have any queries regarding these instructions, contact your local dealer.

Safety and Care Advice For Gas Cylinder

Gas and Regulator

- This barbecue can use either propane or butane or propane/ butane mixed LPG (liquid petroleum gas)

bottled gas. Propane bottles, will supply gas all year round, even on cold winter days. Butane bottles will supply sufficient gas in summer, but it may affect the performance of the barbecue and restrict the heat output available from the burners, particularly once the gas temperature starts to fall below +10°C. A spanner may be required to change gas bottles.

- The hose should hang freely with no bends, twisting, tension, folds, or kinks that could obstruct free flow of gas. Always inspect the hose for cuts, cracks, or excessive wear before use.
- Apart from the connection point, no part of the hose should touch any hot barbecue parts. If the hose shows any sign of damage it must be replaced with a hose suitable for use with LP gas which meets the national standards for the country of use.
- A suitable hose must comply with EN16436-1, and the length should not exceed 1.5 metres.
- For optimal performance, we suggest to use a 5-15kg gas bottle. The maximum dimension of the gas bottle is dia 31.5cm and height 58cm.

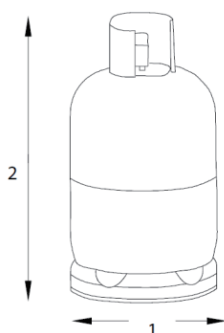

Never mount the gas bottle under the barbecue on the base shelf as this could result in serious injury to the user, other people and/or property. **Always place the gas bottle at the side of the appliance. The gas bottle should be sited as far away from the appliance as possible without straining the hose.** This appliance is only suitable for use with low-pressure butane or propane gas and fitted with the appropriate low-pressure regulator via a flexible hose. The hose should be secured to the regulator and the appliance with hose clips/nut. This barbecue is set to operate a 28-30 mbar regulator with butane gas or a 37mbar regulator with propane gas. Use a suitable regulator certified to EN16129. Please consult your LPG dealer for information regarding a suitable regulator for the gas cylinder.

- Max 9" side cooker is allowed for this appliance.

INSTALLATION

Selecting a Location

This barbecue is for outdoor use only and should be placed in a well-ventilated area, and on a safe and even surface. Never place your barbecue below ground level. Take care to ensure that **the barbecue must be used on an incombustible floor**. The sides of the barbecue should NEVER be closer than 1 metre from any combustible surface, including trees and fences and make sure that there are no heat sources near the barbecue (cigarettes, open flames, spark etc.). Keep this barbecue away from any flammable materials!

Precautions

Do not obstruct any ventilation openings in the barbecue body. Position the gas bottle on level ground

next to the barbecue and safely away from any source of heat. Should you need to install or change the gas bottle, confirm that the barbecue is switched off, and that there are no sources of ignition (cigarettes, open flame, sparks, etc.) near before proceeding.

Fixing a Regulator to the Gas Bottle

Confirm all barbecue control knobs are in the off position. Connect the regulator to the gas bottle according to your regulator and bottle dealer's instructions.

Leak Testing

(Always perform a leak test in a well-ventilated area) Confirm all control knobs are in the off position. Turn the gas on / open the gas control valve on the gas bottle or regulator. Check for leaks by brushing a solution of ½ water and ½ liquid detergent / soap over all the gas system joints, including gas bottle valve connections, hose connections, and regulator connections. NEVER USE AN OPEN FLAME to test for leaks at any time. If bubbles form over any of the joints there is a leak. Turn off the gas supply at the gas bottle. Retighten all joints. Repeat test. If bubbles form again do not use the barbecue and contact your local distributor for assistance. Always wipe the mixed solution (½ water and ½ liquid detergent / soap) from all joints and connections after leak testing.

OPERATION

Warning

- Before proceeding, make certain that you understand the **IMPORTANT INFORMATION** section of this manual.
- Your barbecue is not designed to be used with more than 50% of the cooking area as a solid plate —this includes baking dishes. Full coverage will cause excessive build-up of heat and damage the barbecue. This is not covered by warranty.

Preparation Before Cooking

- To prevent foods from sticking to the cooking surface, please use a long handled brush to apply a light coat of cooking or vegetable oil before each barbecuing session. (Note: When cooking for the first time, paint colours may change slightly as a result. This is normal and should be expected.) During use, the protective coating may come off the cooking surface. This is normal and is not harmful. Line the drip pan with aluminum foil. This will make cleanup easy.

Lighting the Main Burner

1. The lid must be open before lighting.
2. Set all knobs to "Off".
3. Open the gas bottle valve according to operating instruction.
Push in and turn the middle burner knob anti-clockwise until it reaches the ignition sign and a click sound is heard.
4. Then push in and turn the left or the right knob same way until the burner is lit.
5. If the burner does not light, turn all knobs "Off" and repeat Step 4 and 5 after 5minutes.

Lighting the Side Burner

1. **Push in and turn the knob anti-clockwise to "Max" position. If the burner does not light, turn the knob "Off", and repeat process 1.**
2. **Adjust burner control knob for desire cooking setting.**

Application

Grill Cooking

The burners heat up the flame tamer underneath the grill, which in turn heats the food on the grill. The natural food juices produced during cooking fall onto the hot flame tamer below and vaporise. The subsequent rising smoke bastes the food, as it travels upwards, imparting that unique barbecued flavor.

Roasting Hood Cooking

Barbecues equipped with a roasting hood give the option to form an 'oven' for roasting or baking food, such as joints of meat or whole chickens, etc. More even cooking of food will actually be achieved by using the barbecue with the hood down. However, this should only be done with the burners on low.

For best results, place the food you wish to bake or roast on a metal baking tray and set it on one side of the cooking grill.

Turn the burner directly under the food to the OFF position and turn all other burners to a LOW to MEDIUM position.

Close the hood to cook the food 'indirectly'. Avoid lifting the hood unnecessarily as heat is lost every time the hood is opened. If the hood is opened during cooking please allow extra time for the barbecue to regain its temperature and complete the cooking. Use the temperature gauge (if applicable) to monitor the heat of the barbecue.

If the internal heat becomes too high, turn the burners down to the low position. It is not necessary or advisable to have all of the burners on high when the hood is closed.

DO NOT ALLOW YOUR BARBECUE TO OVERHEAT. Take care when opening the hood as hot steam can be released on opening.

Flare-Up Control *Very Important Notice*

Flare-ups occur when meat is barbecued, and its fat and juices fall upon the hot flame tamer. Smoke of course helps give food its barbecued flavour, but it is best to avoid excessive flare-up to prevent food being burned. To control flare-ups, it is ABSOLUTELY ESSENTIAL to trim away excess fat from meat and poultry before grilling, use cooking sauces and marinades sparingly and try to avoid very cheap cuts of meat or meat products as these tend to have a high fat and water content. Also, the burners should always be placed on the low setting during cooking.

When flare-ups do occur, they can usually be extinguished by applying baking soda or salt directly onto the flame tamer. Always protect your hands when handling anything near the cooking surface of the barbecue and take care to protect yourself from the flames.

If a fat fire occurs, please see the instructions given below.

Fat Fires

Empty and clean the drip tray, of food debris after each cooking session. If the barbecue is to be used for large gatherings, it will be necessary to turn off and cool the barbecue every two hours to remove food debris from the drip tray, and clean it out. The time between cleaning may need to be reduced if very fatty foods or cheap meat products are being cooked. Failure to do this may result in a fat fire, which may cause injury and could seriously damage the barbecue.

In the event of a fat fire:

If safe to do so, turn all control knobs to the 'off' position.

Turn off the gas supply at the gas bottle.

Keep everyone at a safe distance from the barbecue and wait until the fire has burnt out.

Do not close the hood or lid of the barbecue.

NEVER DOUSE A BARBECUE WITH WATER. IF AN EXTINGUISHER IS USED, IT SHOULD BE A POWDER TYPE.

DO NOT REMOVE THE DRIP TRAY.

If the fire does not seem to be abating or appears to be worsening, contact your local Fire Brigade for assistance.

End of Cooking Session

After each cooking session, turn the barbecue burners to the “high” position and burn for 5 minutes. This procedure will burn off cooking residue, thus making cleaning easier. Make sure the hood is open during this process.

Turning Off Your Barbecue

When you have finished using your barbecue, turn all the control valves fully clockwise to the “Off” position, then switch off the gas supply at the bottle.

Wait until the barbecue is sufficiently cool before closing the hood or lid.

Care and Maintenance

Flame Tamer

Remove any food residue from the flame tamer surface with a plastic or wooden scraper or brass wire brush. Do not use a steel scraper or wire brush. Clean with hot soapy water and rinse well.

Drip Tray After every use, empty and clean the drip tray of any fat or food particles, using a plastic or wooden scraper if necessary.

Failure to keep it clean, and excessive build up can result in a fat fire. This can be hazardous and severely damage the barbecue. This is not a fault in the barbecue and is therefore not covered by the terms of the warranty. If required, the tray can be washed in hot soapy water.

Barbecue Body

Regularly remove excess grease or fat from the barbecue body using a cloth wrung out in hot soapy water and dry thoroughly. Excess fat and food debris can be removed from inside the body using a soft plastic or wooden scraper. It is not necessary to remove all the grease from the body. If you need to clean fully, use hot soapy water and a cloth, or nylon-bristled brush only. Do not use abrasives. Remove cooking surfaces and burners before full cleaning. Do not immerse the gas controls or manifold in water. Check burner operation after carefully refitting into body.

A stainless steel cleaner may be used on stainless steel parts if required.

Whenever a barbecue is being assembled for the first time or its burners are being cleaned, make sure each gas valve tip goes into the burner venturi tube completely during the assemble or re-assemble process.

Regularly clean your barbecue between uses and especially after extended periods of storage. Ensure the barbecue and its components are sufficiently cool before cleaning. Do not leave the barbecue exposed to outside weather conditions or stored in damp, moist areas.

Never douse the barbecue with water when its surfaces are hot.

Never handle hot parts with unprotected hands.

In order to extend the life and maintain the condition of your barbecue, we strongly recommend that the unit be covered when left outside for any length of time, especially during the winter months. Even when your barbecue is covered for its protection, it must be inspected on a regular basis as damp or condensation can form which may result in damage to the barbecue. It may be necessary to dry the barbecue and the inside of the cover. It is possible for mould to grow on any fat remaining on parts of the barbecue. This should be cleaned off smooth surfaces with hot soapy water.

Any rust that is found that does not come into contact with the food should be treated with a rust inhibitor and painted with barbecue paint or a heat resistant paint. A chrome cleaner may be used on chrome parts if

required. To prevent rusting, wipe chrome plated parts with cooking oil after rinsing and drying.

Cooking Surfaces

When the barbecue has cooled, clean with hot soapy water. To remove any food residue, use a mild cream cleaner on a non-abrasive pad. Do not use scouring pads or powders as they can permanently damage the finish. Rinse well and dry thoroughly. Due to the weight of the cooking surfaces, we do not recommend cleaning in a dishwasher.

It is quite normal for surface rust to be present on the cooking surface. If rust appears between uses or in storage, clean with a soft brass wire brush. Be careful not to damage the cooking surface, re-oil and cure.

Burner

Provided that they are operating correctly, in normal usage, burning off the residue after cooking will keep the burners clean.

The burners should be removed and cleaned annually, or whenever heavy build-up is found, to ensure that there are no signs of blockage (debris, insects) in either the burner portholes or the primary air inlet of the burners. Use a pipe cleaner to clear obstructions.

When refitting the burners, be careful to check that the neck of the burner fits over the valve outlet. It is quite normal for surface rust to be present on the burners. If rust appears between uses or in storage, clean with a soft brass wire brush.

Carbon Monoxide Hazard

Barbecue Hood or Lid

Use a non-abrasive cloth or pad and clean with hot, soapy water. Do not use scouring pads or powders as they can permanently damage the finish.

Trolley

Wipe with a cloth wrung out in hot soapy water and dry.

Fixings

All screws and bolts, etc. should be checked and tightened on a regular basis.

Storage

Ensure the barbecue is properly cooled before covering or storing. Store your barbecue in a cool dry place. It must be inspected on a regular basis as damp or condensation can form which may result in damage to the barbecue. It may be necessary to dry the barbecue and the inside of the cover if used.

Mould can grow under these conditions and should be cleaned and treated if required. Any rust that is found that does not come into contact with the food should be treated with a rust inhibitor and painted with barbecue paint or a heat resistant paint.

Cooking grills should be coated with cooking oil.







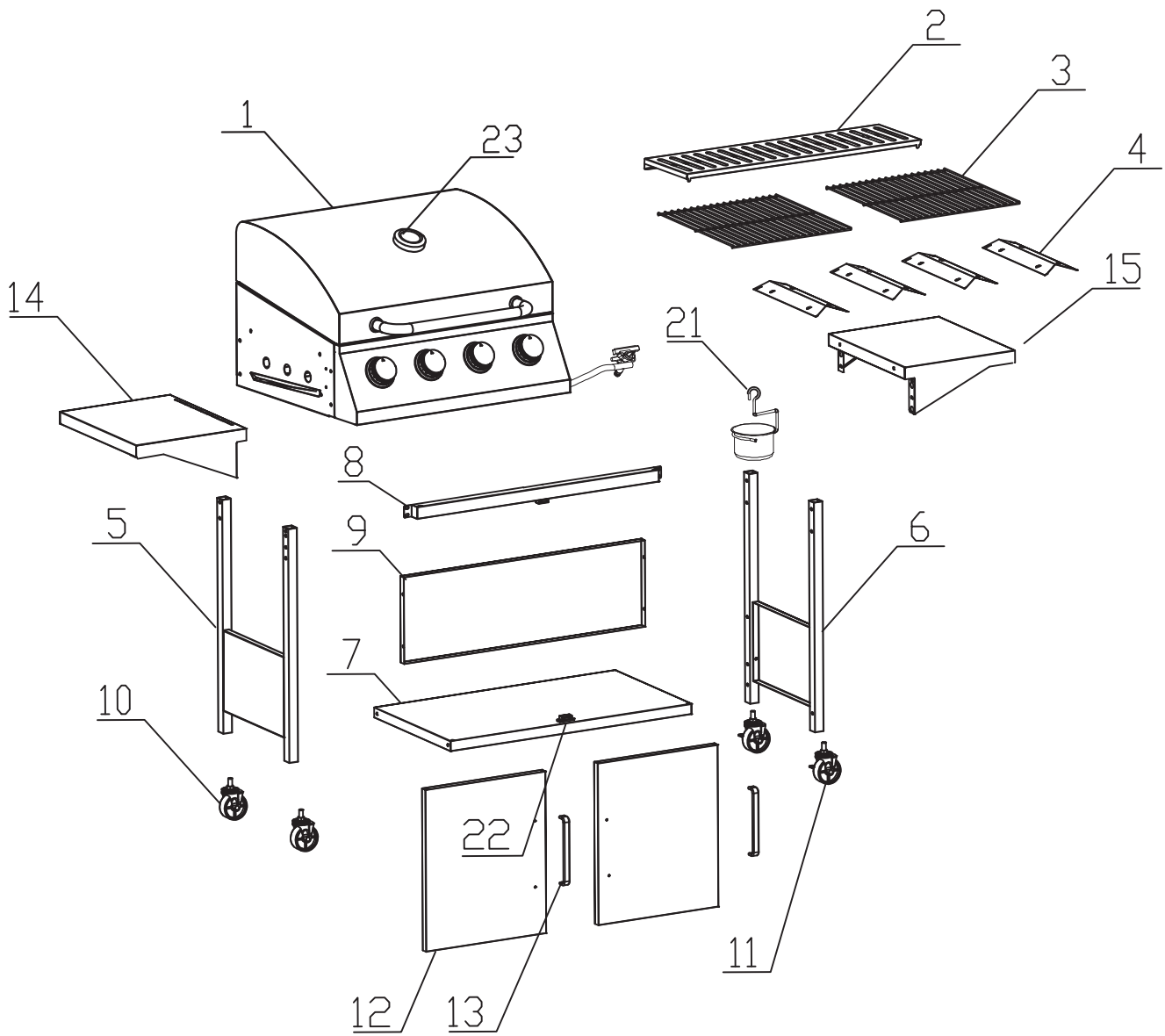









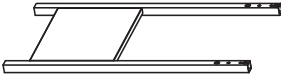
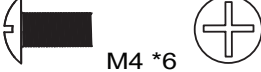

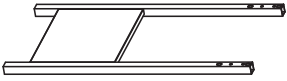



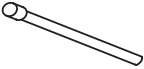

Cover the burners with aluminum foil in order to prevent insects or other debris from obstructing the burner holes.



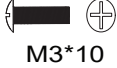

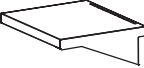
If the barbecue is to be stored indoors, the gas bottle must be disconnected and left outside. The gas bottle should always be stored outside, in a dry, well-ventilated area, away from any sources of heat or ignition. Do not let children tamper with the bottle.

When using the barbecue after extended periods of storage follow the cleaning procedures.



PACKING DETAILS:TOTAL 2 BOXES

PARTS LIST-BOX 1/2					
No.	Pic.	Qty	No.	Pic.	Qty
1		1	21		1
3		2	22		2
4		4	23		1
5		1	A	 M4 *6 	4 +1(spare)
6		1	B	 M5*12 	24 +1(spare)
8		1	C		2
10		2	E		2
11		2	F	 M3	2
13		2	G	 M3*10 	2
14		1	H	 M3*10	2
15		1	J		1

PARTS LIST-BOX 2/2					
No.	Pic.	Qty	No.	Pic.	Qty
2		1	9		1
7		1	12		2

Assembly

Note: Please do not tight the screws and nuts till all assembly steps completed.

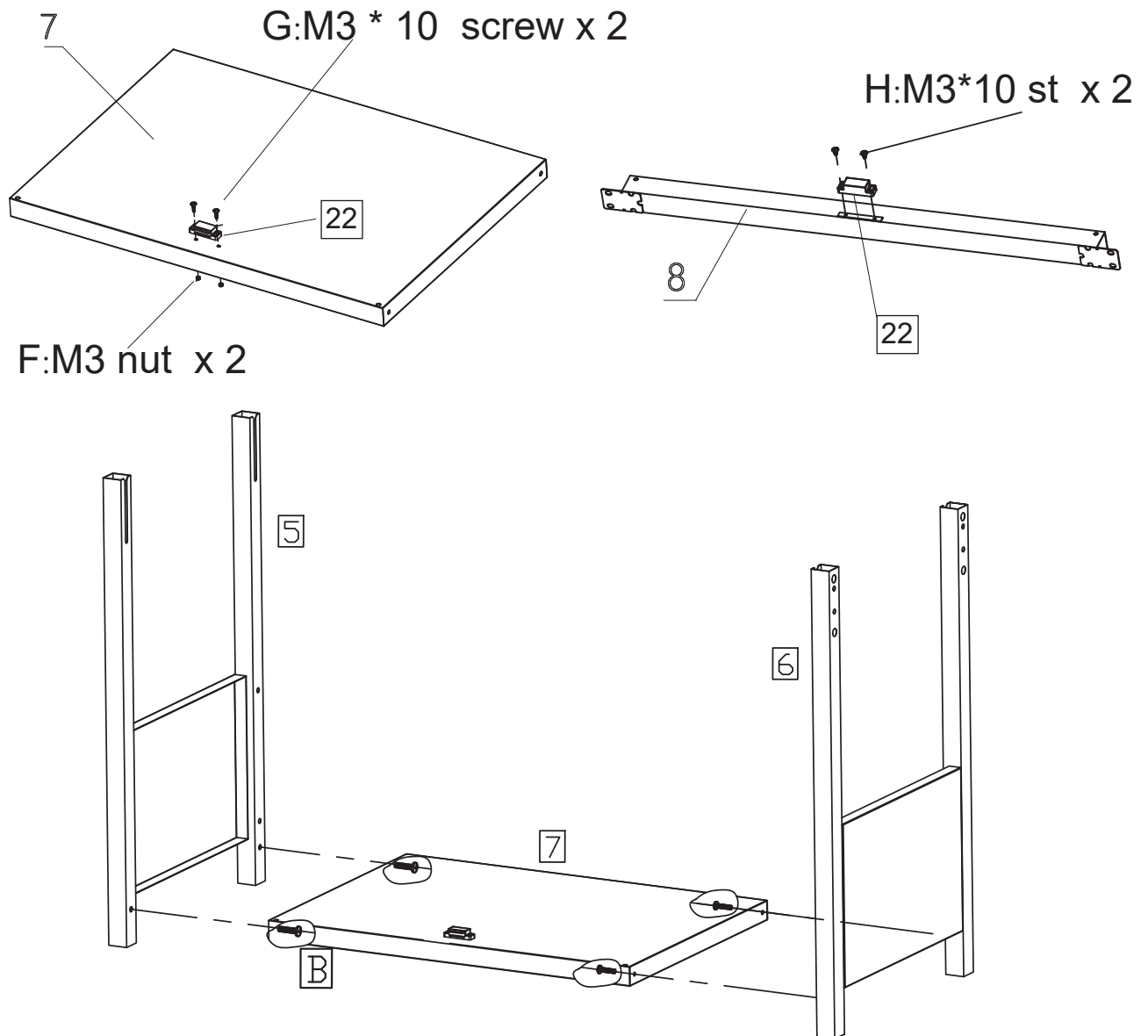

1. Assemble the LH and RH frame(5&6) to bottom shelf (7) with 4pcs M5 screws (B).

Assembly

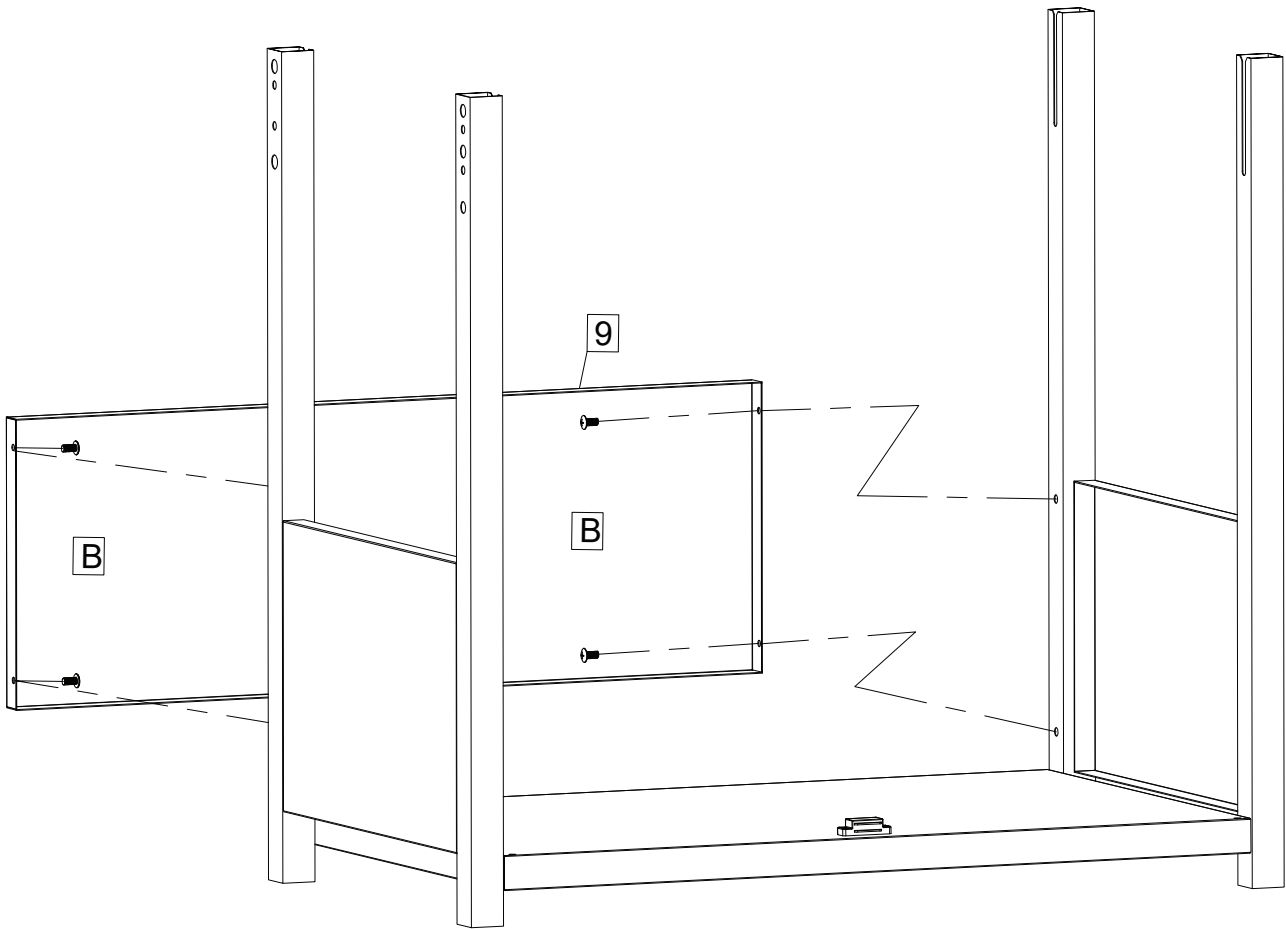

2. Assemble the back shelf (9) to the frames with 4 pcs M5 screws (B).

Assembly

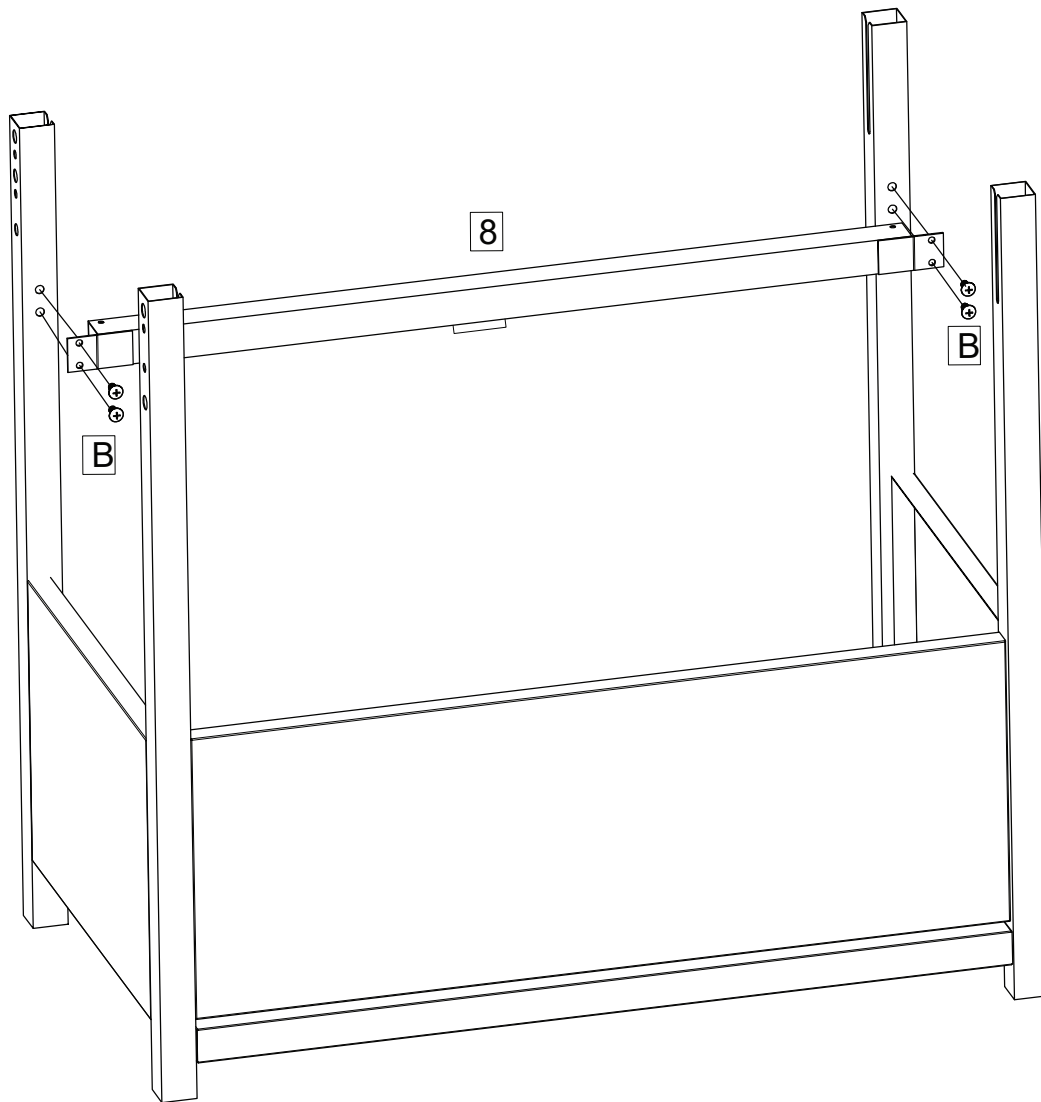

3. Assemble the front beam (8) to the front of frames with 4pcs M5 screws (B).

Assembly

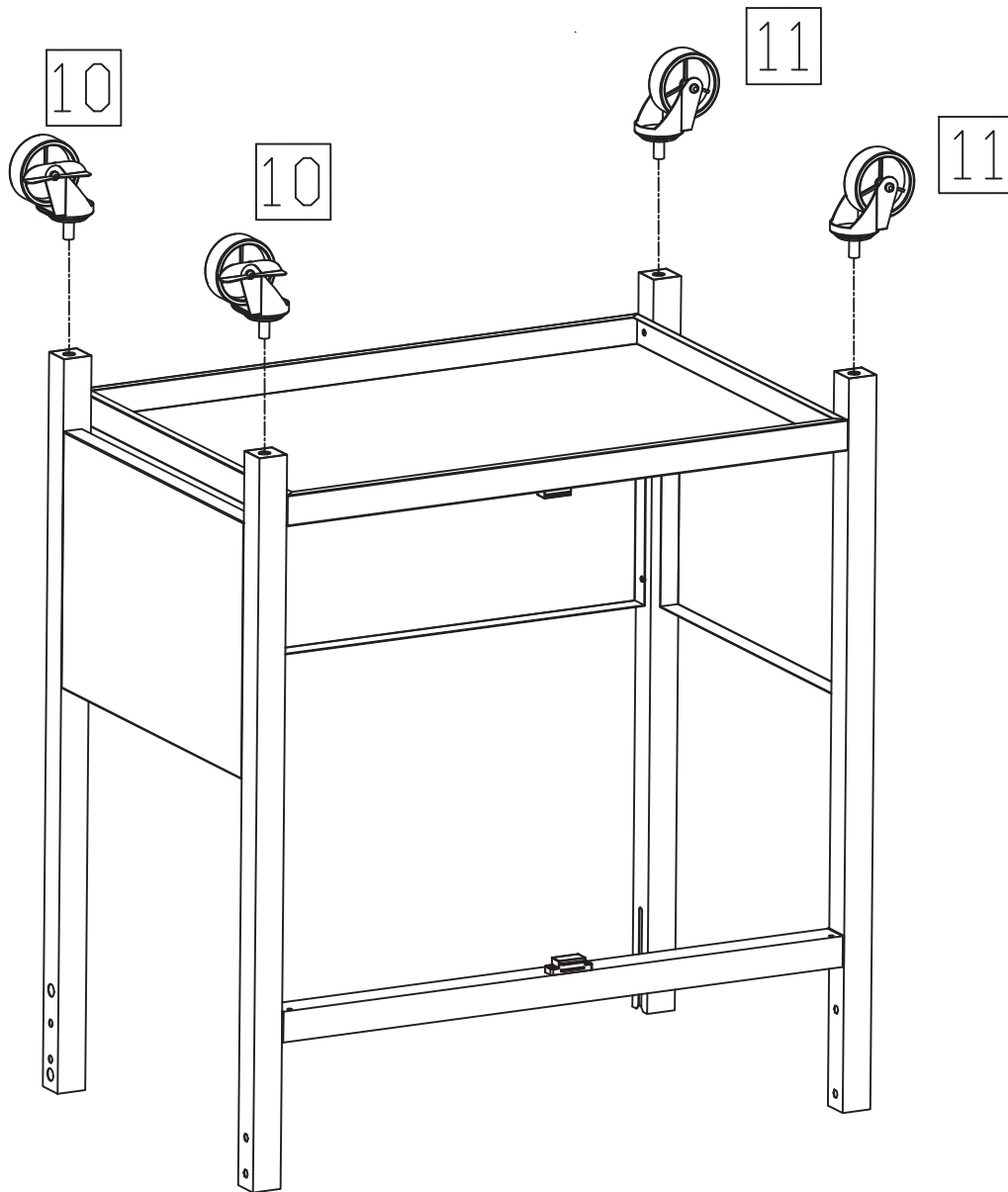

4. Assemble the 4pcs wheels (10&11) to the end of frame legs.
Note: the 2pcs wheels with break (10) are always in the same side.

Assembly

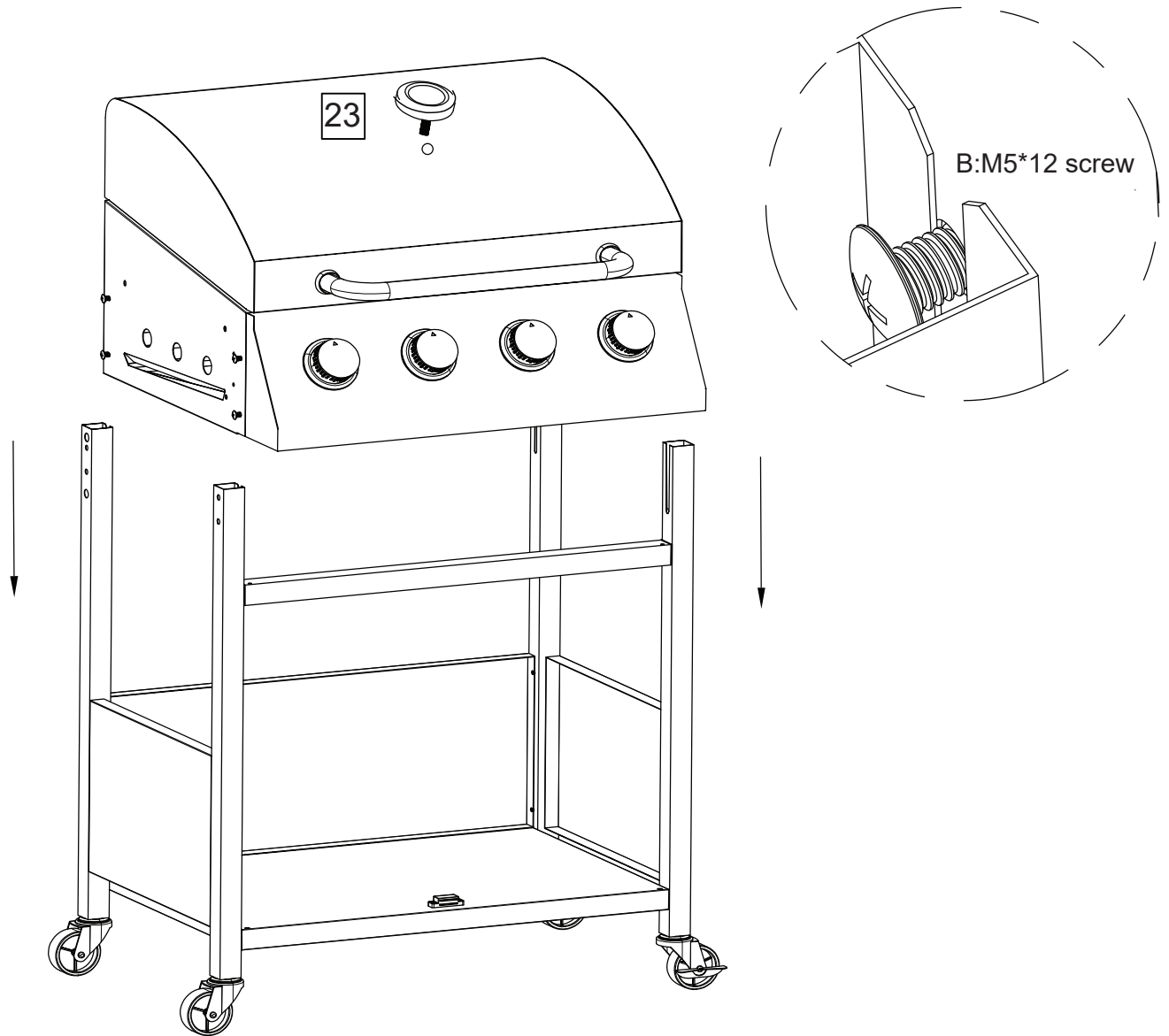

5. The body (1) is slid into the frame legs with 8 pcs pre-assembled M5 screws (See detailed pic.). Tight screws after body slid into position.

Thermometer (23) is fixed to the lid by its own screw.

Note: make sure the 8pcs screws are pre-assembled before sliding.

Assembly

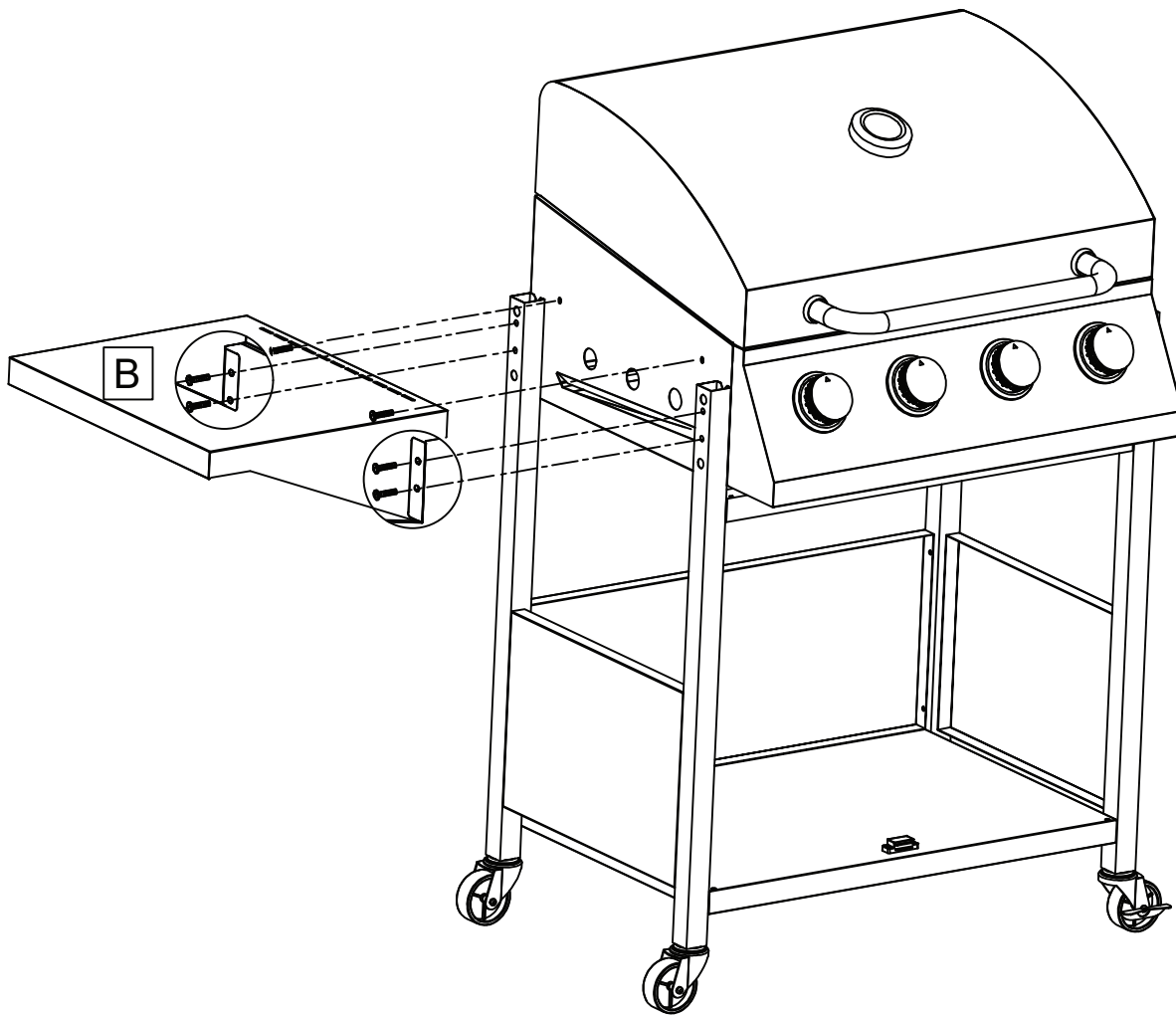

6. LH side shelf (14) is assembled to the body with 6 pcs M5 screws (B).

Assembly

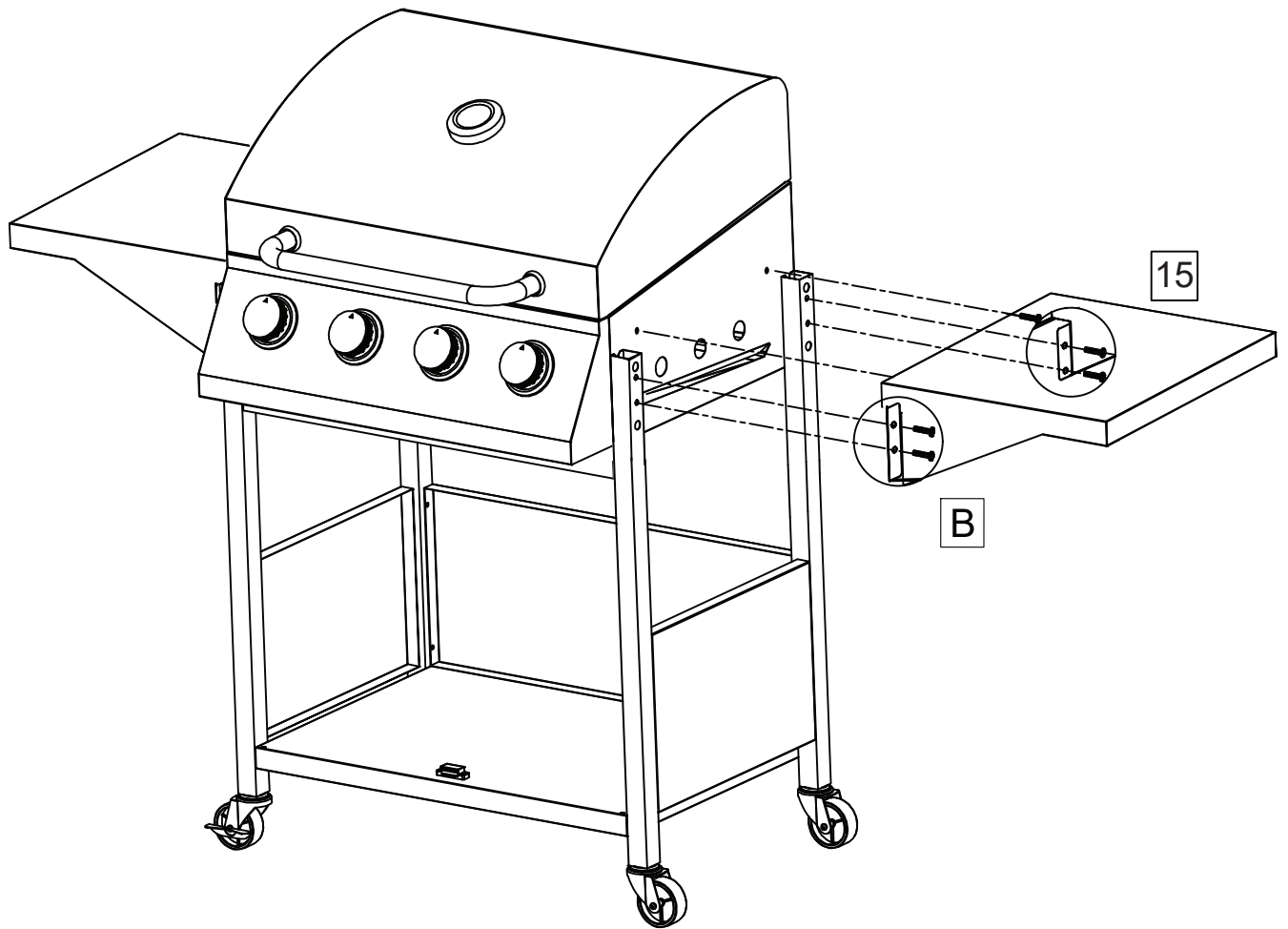

7. RH side shelf (15) is assembled to the body with 6 pcs M5 screws (B).

Assembly

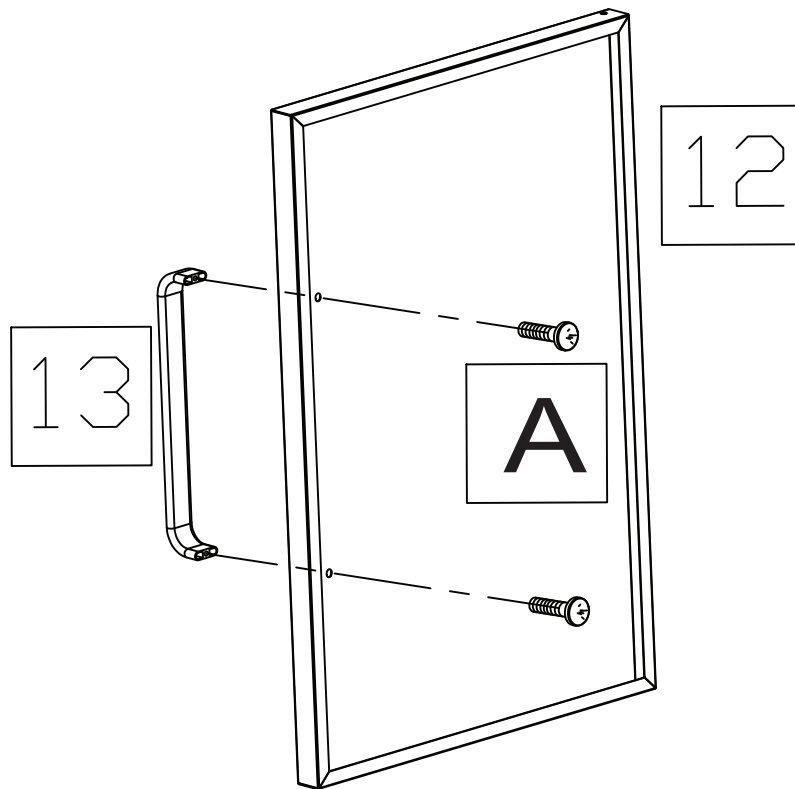

8. Handles (13) are assembled to front doors (12) with 4pcs M4 screws (A). Totally 2 pcs doors.

Assembly

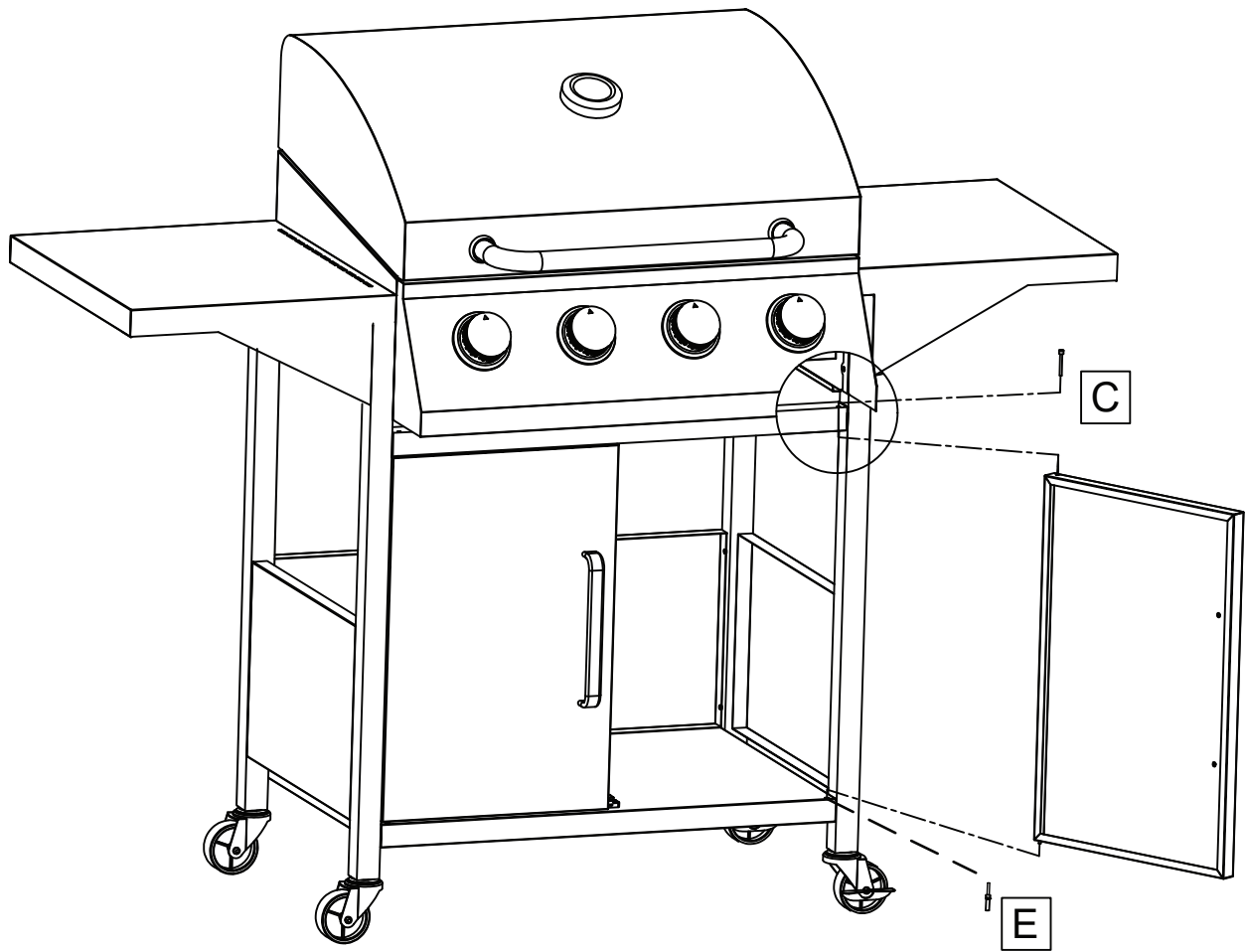

9. Doors are assembled to frames' front legs with top and bottom pins (C&E).

Assembly

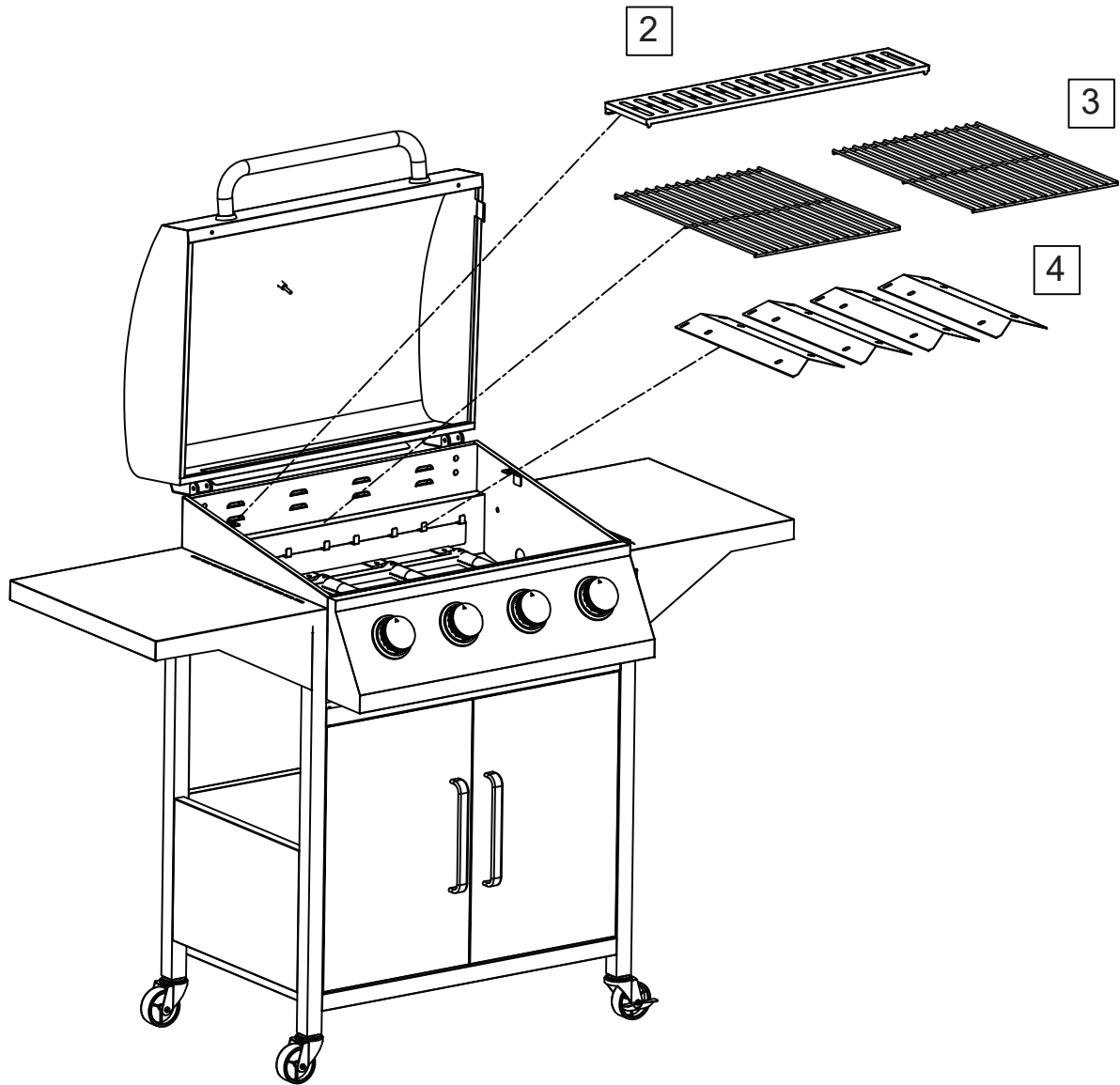

10. Warming grid (2), cooking grids (3) and heat tents (4) are fixed into the body.

Assembly

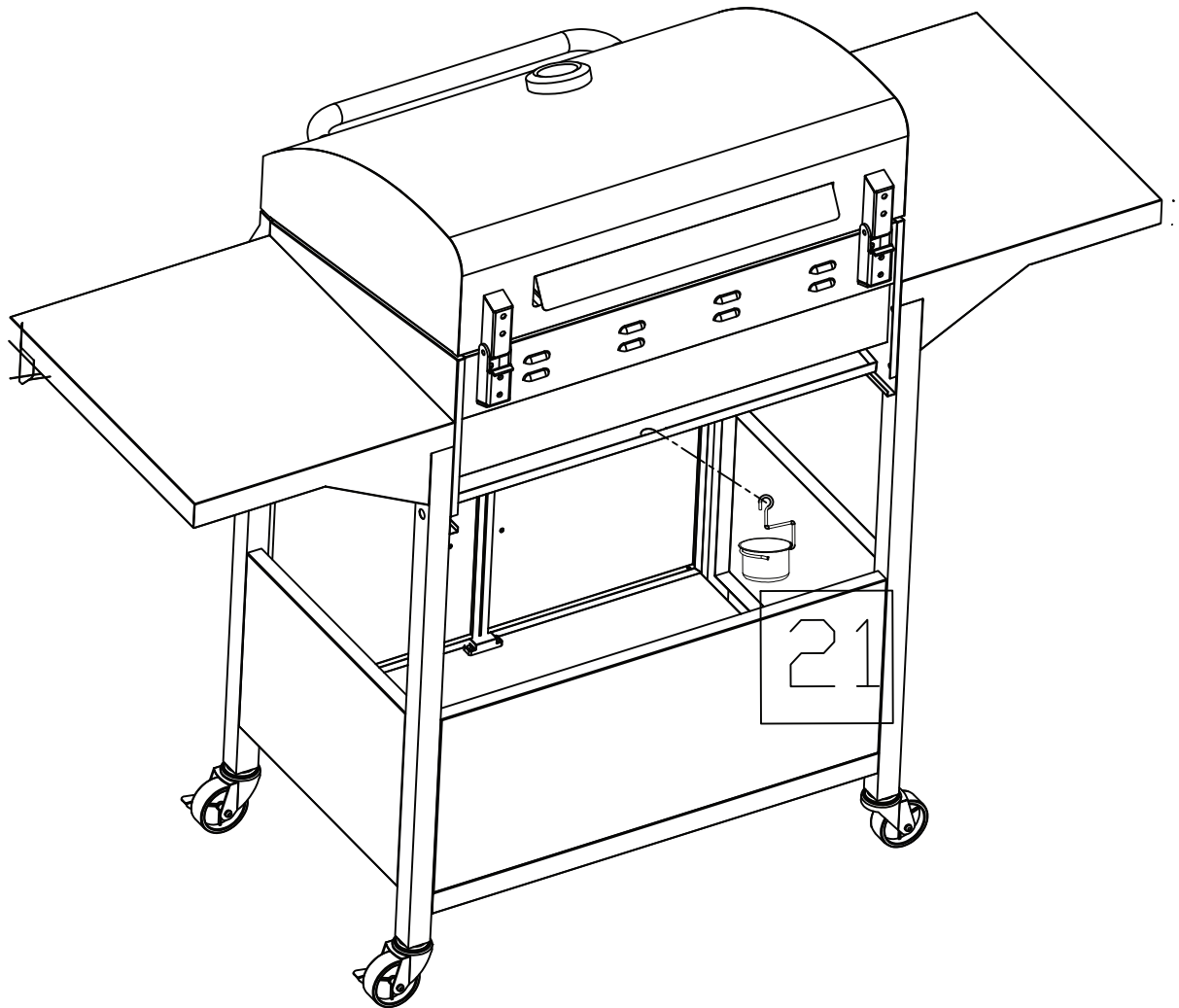

11. Oil cup (21) is assembled to the oil pan.

Assembly

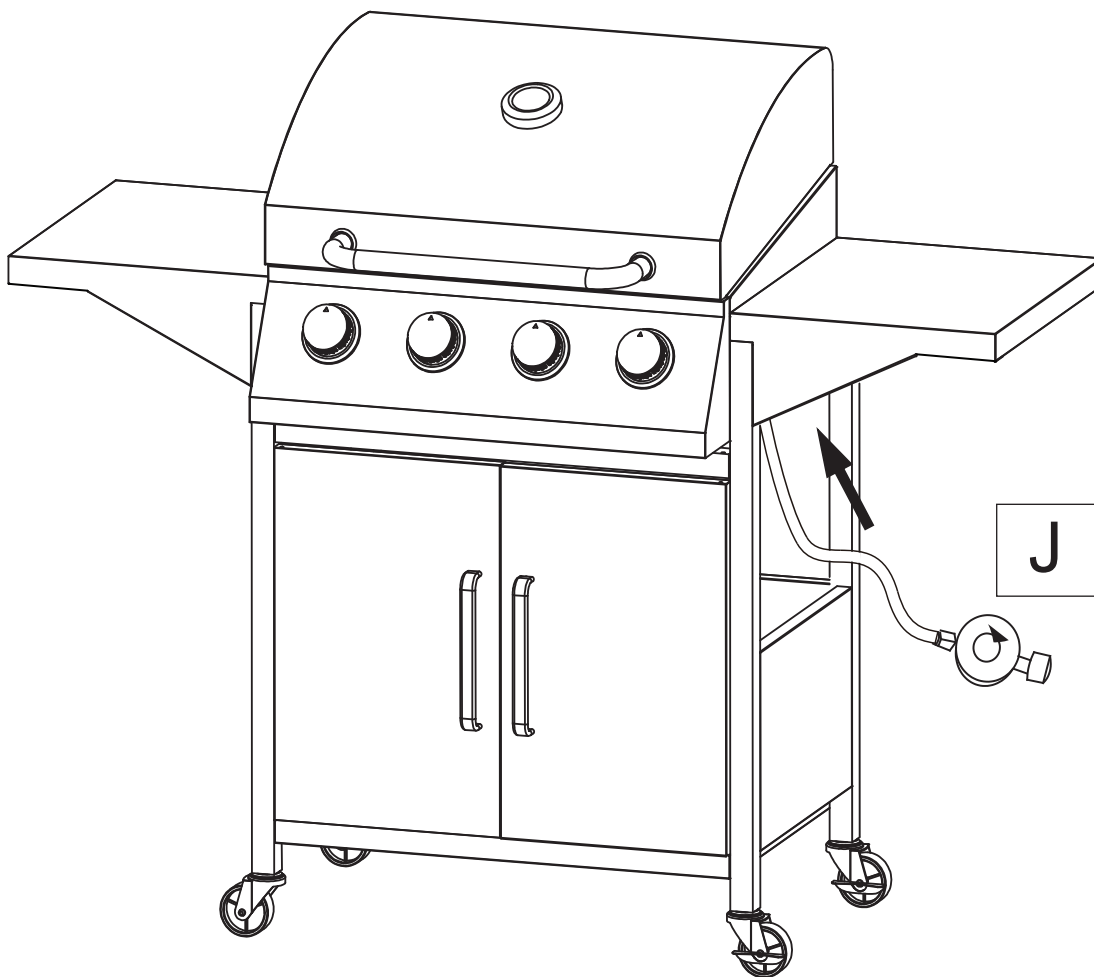

Tight all screws before use
Assembly completed

Model:	YF-01JY04-A (846-103V71)		
PRODUCT	Outdoor gas grill		
Manufacturer: Cixi Weinuo Machinery Manufacturing Co., Ltd. Address: No. 58 Longzhen Ave, Longshan Industrial Zone, Cixi, Ningbo, China	Gas consumption		Butane: 843 g/h Propane: 828 g/h
Dimensions (H X D X W)	132.0*58.0*109.5 cm		
Cooking area (W X D)	59.0*41.5 cm		
Warming area (WXD)	54.5*10.6 cm		
Cooking height (H)	85.0 cm		
Appliance category	I3+ (28-30/37)	I3B/P (30)	I3B/P (37)
Gas type and pressure	Butane at 28-30 mbar propane at 37 mbar	G30 (Butane), G31 (Propane) and their mixtures at 28-30 mbar	G30 (Butane), G31 (Propane) and their mixtures at 37 mbar
Main burner(s) orifice size	φ0.85 mm	φ0.85 mm	φ0.79 mm
Side burner orifice size			
Nominal heat input	Main burner(s): 2.9kW *4= 11.6 kW		
Destination country	IE, CH, CY, CZ, ES, FR, GB, GR, IE, IT, LT, LU, LV, PT, SI, SK, TR	BE, BG, CY, CZ, DK, EE, FI, FR, GB, GR, HR, HU, IT, LT, LU, LV, MT, NL, NO, RO, SE, SI, SK, TR	PL AT, CH, CZ, DE, LU, SK
Pressure regulator type	included for different destination countries (PRESSURE REGULATOR TYPES)		

Use outdoors only!

Read the instructions before using the appliance!

WARNING! Accessible parts may be very hot. Keep yong children away.

WARNING! Do not use spirit or petrol for lighting or re-lighting!



UK

If you have any questions, please contact our customer care center.

Our contact details are below:



0044-800-240-4004



enquiries@mhstar.co.uk

IMPORTER ADDRESS:

MH STAR UK LTD

Unit 27, Perivale Park,

Horsenden lane South

Perivale, UB6 7RH

MADE IN CHINA

ES

Si tiene alguna pregunta, comuníquese con nuestro Centro de Atención al Cliente. Nuestros datos de contacto son los siguientes:



0034-931294512



atencioncliente@aosom.es

IMPORTADOR:

SPANISH AOSOM, S.L.

C/ ROC GROS, N° 15. 08550, ELS HOSTALETS DE BALENYÀ, SPAIN.

B66295775

WWW.AOSOM.ES

ATENCIONCLIENTE@AOSOM.ES

TEL: 931294512

HECHO EN CHINA

FR

Si vous avez la moindre question, veuillez contacter notre centre d'assistance à la clientèle.

Nos coordonnées sont les suivantes:



0033-1-84166106



aosom@mhfrance.fr

Importé par:

MH France

2, rue Maurice Hartmann

92130 Issy-les-Moulineaux

France

Fabriqué en Chine

PT

Se tiver alguma dúvida, por favor contacte o nosso Centro de Atendimento ao Cliente. Os nossos dados de contacto são os seguintes:



0034-931294512



info@aosom.pt.

IMPORTADOR:

SPANISH AOSOM, S.L

C.ROC GROS N.15, 08550. ELS HOSTALETS DE BALENYÀ

TEL: 931294512 (SEG-SEX DAS 7:30H ÀS 16:30H)

INFO@AOSOM.PT

WWW.AOSOM.PT

DE

Wenn Sie Fragen haben, wenden Sie sich bitte an unser Kundendienstzentrum.

Unsere Kontaktdaten stehen unten:



0049-0(40)-88307530



service@aosom.de

ADRESSE DES IMPORTEUR:

MH Handel GmbH

Wendenstraße 309

D-20537 Hamburg

Germany

IN CHINA HERGESTELLT

IT

In caso di dubbio, si prega di contattare il nostro centro assistenza clienti. I nostri dettagli di contatto sono di seguito:



0039-0249471447



clienti@aosom.it

IMPORTATO DA:

AOSOM Italy srl

Centro Direzionale Milanofiori

Strada 1 Palazzo F1

20057 Assago (MI)

P.I.: 08567220960

FATTO IN CINA