

THIS DRAWING MUST NOT BE COPIED OR PASSED TO A THIRD PARTY WITHOUT WRITTEN CONSENT FROM THE MANUFACTURER

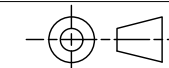

CUSTOMER SIGN:

DATE:

DOUBLE GLAZING SPEC

Outer: 6mm Toughened.
Outer Finishes: Clear
Cavity: 16mm Argon Filled Cavity.
Inner: 8.8mm Laminated.

Description:

Double glazed hermetically sealed glass unit, with thermally broken aluminium ring frame finished to RAL7016.

NBS SPECIFICATION

CAWS
L10 /45 Rooflights
L10/460 Rooflights
Uniclass category
Pr_30_59_72

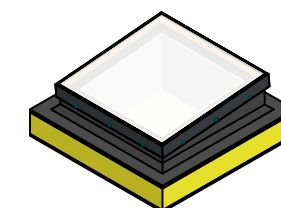

TITLE: Em.Glaze Assembly	
DESCRIPTION: Em.Glaze Economy, Fixed Lid	
PROJECT: Fenestration	
PROJECT NO: P000000	REF NO: Fenestration
PRODUCT: Em.Glaze Manufacture	
PRODUCT CODE: EG	
CUSTOMER NAME: x	
PROJECT ADDRESS: x	
QUANTITY: 1	
DRAWING NO.: Fenestration_EG_B1A_S7_CD_1_1	
DATE: 07/02/2024	CHECKED:
DRAWN: Auto	REVISION: 1
SHEET NO.: 1 of 1	SCALE: DNS
SIZE: A3	UNITS: mm

Detail C

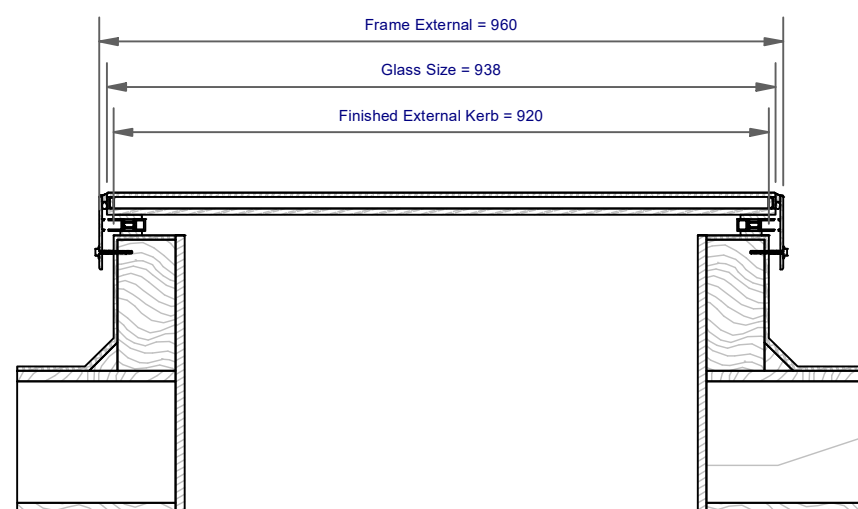
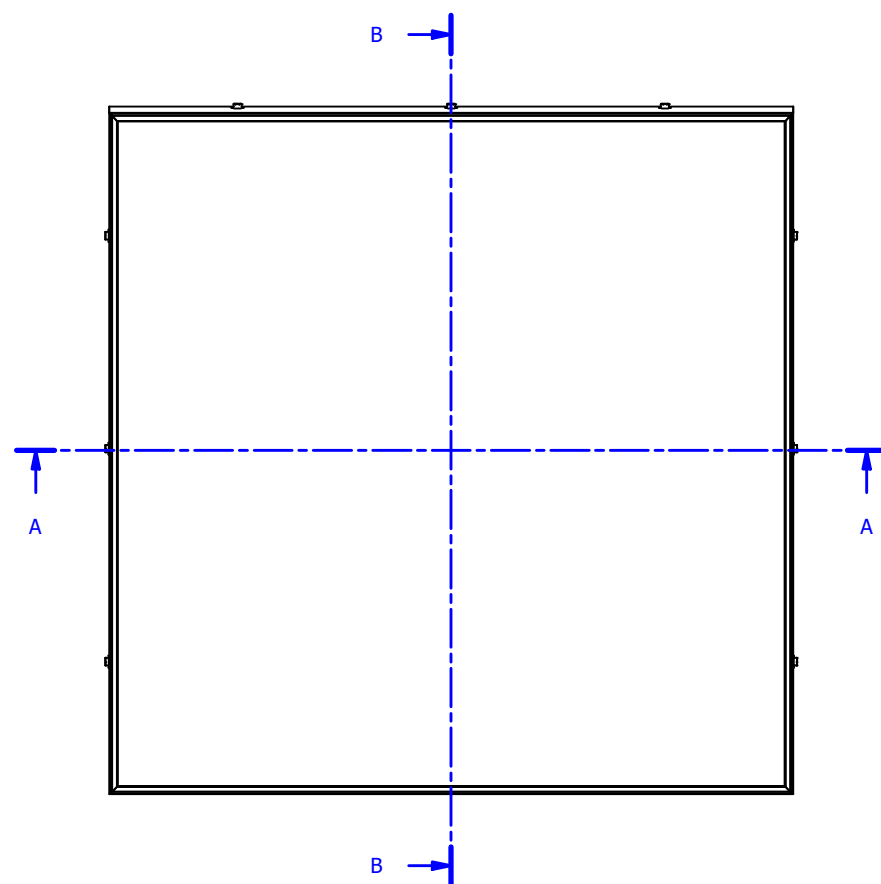
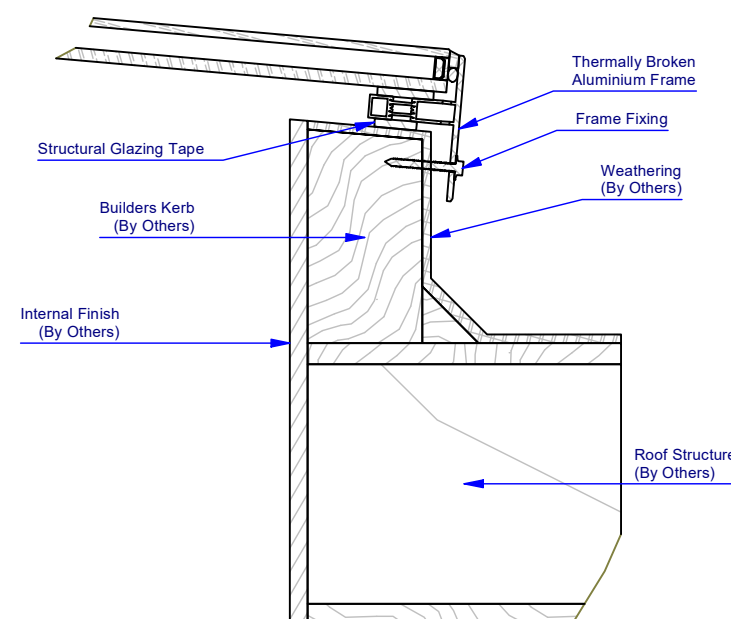

Section A-A

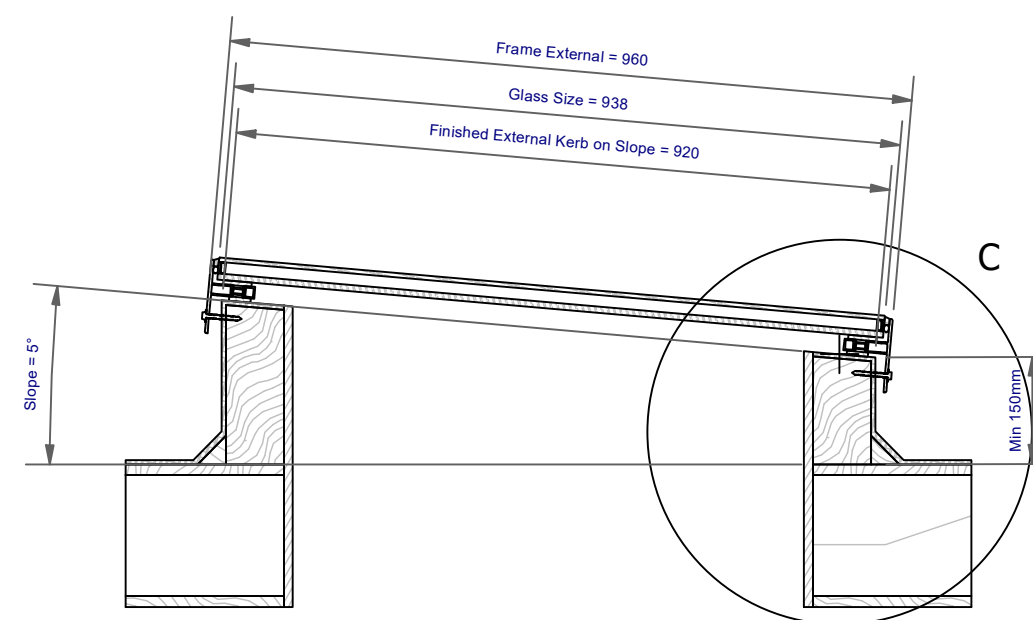

Section B-B

Thermal Stress Note
To provide the highest performance of non fragility and security, the unit incorporates laminated internal panes. For standard (annealed) laminate inner panes, guidance regarding thermal stress fracture risk is available on website or by contacting technical team.
To reduce risk it is recommended to keep curb widths under 120mm, avoid partial shading or rapid internal heating or cooling direct or close to the glass.
If higher risks cannot be mitigated then alternative heat strengthened or toughened glass inner panes should be considered.

CAUTION CDM: Hazard Identification - Handling materials
Manual Handling Operations Regulations (MHOR 1992) sets out a clear ranking of measures for dealing with risks from manual handling. Ensure measures are considered at all times.
Other measures:
• Hand protection (mandatory) to: BS EN 388:1994.
• Wear appropriate PPE required for the task.
• Refer to applicable risk assessment for further details.

Whitesales advise an installation with a minimum pitch of 5° for Rooflight units to minimise water pooling. Whilst the product can be installed flat without detriment to the warrantee. Whitesales cannot be held responsible for any excessive pooling of water to the surface of the Rooflight post installation.



Kerb details shown are indicative only. Detail is designed by others.
It is the responsibility of the curb designer to ensure that the curb is structurally adequate to support the rooflight product.