



www.trendsuk.co.uk

Trends UK Ltd,
Greatworth Hall, Banbury, OX17 2DH, UK
Email: trends@jgdirect.net

Trends Toys Ireland, Ground Floor,
71 Lower Baggot Street, Dublin D02 P593

 **Customer Services:**
+44 (0)1702 208175

Item No. MWH10



Please retain the information in this manual
for future reference.

Contents, colour, designs and decorations
may vary from those shown in the
photographs.

Printed in China.



If at any time in the future you should need to dispose of
this product please note that Waste Electrical products
should not be disposed of with household waste. Please
recycle where facilities exist. Check with your Local
Authority or retailer for recycling advice. (Waste
Electrical and Electronic Equipment Directive, WEEE)

0222 01

**MACHINE
WORKS**

V8 ENGINE 



**OVER
250
PARTS!**

INSTRUCTION MANUAL
FOR THE CONSTRUCTION OF THE V8 ENGINE MODEL

For the AR features please refer to the separate leaflet

AGES 10+

MWH10 Machine Works V8 Engine

Printed in China

Please retain the information in
this manual for future reference.



BUILD YOUR OWN V8 ENGINE

Contents

Introduction	2
Notes and advice	5
Parts list	6
Assembling the engine	12
How an engine works	28
Keeping a car and its engine healthy	34
Reducing pollution and saving on fuel bills	34
Basic engine terms	35
Notes	38

INTRODUCTION

There are many different shapes and sizes of internal combustion engine, from small single-cylinder motorcycle engines, right up to large multi-cylinder engines used in industrial machinery and ships. This kit is designed to represent a car engine, so we'll concentrate on car engines for this introduction.

Production-car engine designs have included single-, two-, three-, four-, five-, six-, eight-, ten-, twelve- and sixteen-cylinder layouts, the most common design being the four-cylinder layout used in most family cars. Both petrol (gasoline) and diesel engines are available, but our model represents a four-stroke petrol (gas) engine. The four-stroke engine cycle is described in more detail at the rear of this manual.

The layout of the cylinders in an engine may be either 'in-line' (in a row, one behind the other), 'V' (two rows of cylinders forming a V-shape), or in a few rare cases, with multi-cylinder engines, 'W' (three rows of cylinders forming a W-shape). Most early engines had 'in-line' cylinders. Generally, the higher the number of cylinders, the more power the engine will produce, and the smoother the engine will run.

The disadvantage of a multi-cylinder engine is its size, which makes it more difficult to fit into the space available in a car. One way of making a multi-cylinder engine more compact is to arrange the cylinders in two rows or 'banks' in a 'V'-shape, which reduces the length and height of the engine. It may also be possible to mount various ancillary components within the 'V' between the cylinder banks, taking up less space. Over the years, V4, V5, V6, V8, V10, V12 and V16 engine designs have been used, but by far the most common design is the V8.

The V8 is a very flexible engine design, and can be compact or very large, depending on its intended use – compact for use in sports cars and racing cars, or larger designs for use in dragsters, boats and even tanks! The first V8 engines appeared at the beginning of the 20th Century in speedboats, aircraft and high-performance road and racing cars, but the first mass-produced V8 car engine, made by Cadillac in the US, appeared in 1914. Today, V8 car engines tend to be reserved for high-performance road and racing cars due to their higher cost and fuel consumption compared to smaller engines.

The main reasons for the V8 engine's popularity are its relatively high power output for its size and weight, its affordability compared to other multi-cylinder engines, the V8's smooth performance and, not least, its sound! A V8 engine runs more smoothly than many engines with fewer cylinders, because a power stroke (see four-stroke cycle explanation at the rear of this manual) takes place at every 90-degree rotation of the crankshaft. In comparison, a power stroke is only produced every 180-degrees in a four cylinder engine, and every 120-degrees in a six cylinder engine. The more frequent power strokes of a V8 engine provide smoother running, putting less stress on the engine. This has the added bonus of improving overall performance and driveability.

On a V8, the cylinders are arranged in two banks of four, and the angle between the two banks varies depending on design, but is usually 90-degrees or less. The most common angles

INTRODUCTION

are 90-degrees, 60-degrees or 45-degrees. The eight pistons and connecting rods in a V8 are all attached to a single crankshaft, but each bank of cylinders has its own cylinder head and valve gear, and so a V8 is rather like two four-cylinder engines joined together.

There are two fundamentally different crankshaft designs used in V8s – 'cross-plane' and 'flat-plane'. Most V8 road-car engines tend to use a cross-plane crankshaft, whereas flat-plane crankshafts only tend to be used in high-performance road-car and racing engines.

Cross-plane crankshafts have the crankpins (the piston/connecting-rod assemblies are attached to the crankpins) arranged so that each crankpin is positioned at 90-degrees to its neighbour(s), in such a way that the layout forms an 'X'-shape when viewed from the end of the crankshaft. On a flat-plane crankshaft, each crankpin effectively has two piston/connecting-rod assemblies attached to it – the two centre crankpins positioned at 180-degrees to the two end crankpins, so that the crankpin layout forms a straight line when viewed from the end of the crankshaft.

A cross-plane engine relies on large counterweights attached to the crankshaft to achieve a perfect balance. This means that the crankshaft will have a large rotating mass and as a result, the engine will be slow-revving and unable to accelerate or slow down quickly. V8s with a cross-plane crankshaft are used in most road-car engines, and in the classic Ford V8 family of road-car/racing engines used in the legendary Ford GT40 and AC Cobra.

Our model uses a flat-plane crankshaft. A flat-plane crankshaft is not perfectly balanced, but the balance problem cannot be solved using counterweights. As a result, the crankshaft is lighter than a cross-plane crankshaft, and so has less inertia, allowing the engine to accelerate quickly and to reach high rpm. For this reason, most V8 racing engines (such as F1-car engines) have flat-plane crankshafts, as vibration is not such an important consideration. However, road-car engines with flat-plane crankshafts are usually fitted with a pair of counter-rotating balancer shafts (one on either side of the crankshaft) to reduce vibration and improve passenger comfort. Flat-plane crankshafts are used in some high-performance sports-car engines such as those built by TVR, Ferrari (all the company's V8 road-car engines) and the McLaren MP4-12C road car.

It's important to explain that this kit has been designed to be straightforward and fun to build, and to provide a practical illustration of the principles of a real V8 engine, but it is not intended to be a replica of any specific real-life engine. The model has a flat-plane crankshaft, with two piston/connecting-rod assemblies connected to each crankpin, but no balancer shafts. The cylinder firing order, 1-5-3-7-4-8-2-6, is that used for several real engines, including Ferrari V8 road-car engines. The 'V'-angle on the model is 90-degrees, and the engine has a single overhead camshaft for each cylinder bank, operating the two valves per cylinder via rockers. The two camshafts are driven from the crankshaft by a single toothed belt. The ignition system uses two distributors, one for each cylinder bank, driven from the rear of each camshaft.

NOTES AND ADVICE

- The front of the engine is the end with the timing belt and fan.
- References to the left or right side of the engine mean the left or right side when viewed from the rear. Cylinders 1-4 are on the right side of the engine and cylinders 5-8 are on the left.
- All parts with the suffix 'A' are used to make cylinders 1-4 and all parts with the suffix 'B' are used to make cylinders 5-8.
- Identify the various parts by looking at the list of components and the corresponding illustrations.
- Use a sharp knife to trim any excess plastic from the components after they have been removed from their carrier frames.
- Take care not to over-tighten the screws as this may permanently damage the plastic.
- Non-rechargeable batteries are not to be recharged.
- Rechargeable batteries are only to be charged under adult supervision.
- Rechargeable batteries are to be removed from the toy before being charged.
- Different types of batteries or new and used batteries are not to be mixed.
- Batteries are to be inserted with the correct polarity.
- Exhausted batteries are to be removed from the toy.
- The supply terminals are not to be short-circuited.

PARTS LIST

Qty.	Part	Part No.	Qty.	Part	Part No.
8	Gudgeon pins	1	1	Water pump back	25
8	Connecting rods	2	1	Water pump front	26
16	Piston halves	3	1	Crankshaft pulley	27
8	Connecting rod bearing caps	4	1	Fan pulley	28
1	Crankshaft	5	1	Fan	29
1	Sump pan	6	1	Clutch cover	30
1	Lower crankcase	7	1	Plenum chamber bottom	31
1	Cylinder block	8	1	Plenum chamber top	32
2	Lower cylinder heads	9A & 9B	1	Inlet manifold	33
2	Small cylinder head plates	11A & 10B	1	Dipstick	34
2	Large cylinder head plates	10A & 11B	2	Exhaust manifold	35A & 35B
16	Valve stems	12	1	Flywheel	
8	Exhaust valves	13	2	Distributors with leads and spark plugs	
8	Inlet valves	14	1	Electric motor unit	
16	Rocker arms	15	1	Base	
2	Upper cylinder head	16A & 16B	2	Washers	
10	Rocker bearing caps	17	2	Rocker shaft, 155 mm long	
8	Cams	(A,B,C,D,E,F,G,H)	2	Camshaft, 215 mm long	
8	Cams	(J,J,K,K,L,L,M,M)	2	Camshaft, 215 mm long	
2	Rocker covers	18A & 18B	1	Fan belt	
1	Crankshaft sprocket	19	1	Timing belt	
2	Camshaft sprocket	20	16	Valve springs	
1	Timing alignment tool	21	108	Screws	
4	Idler pulleys	22	1	Screwdriver	
1	Timing belt cover	23	2	Cylinder head gasket	
1	Timing belt cover back plate	24			

PARTS LIST

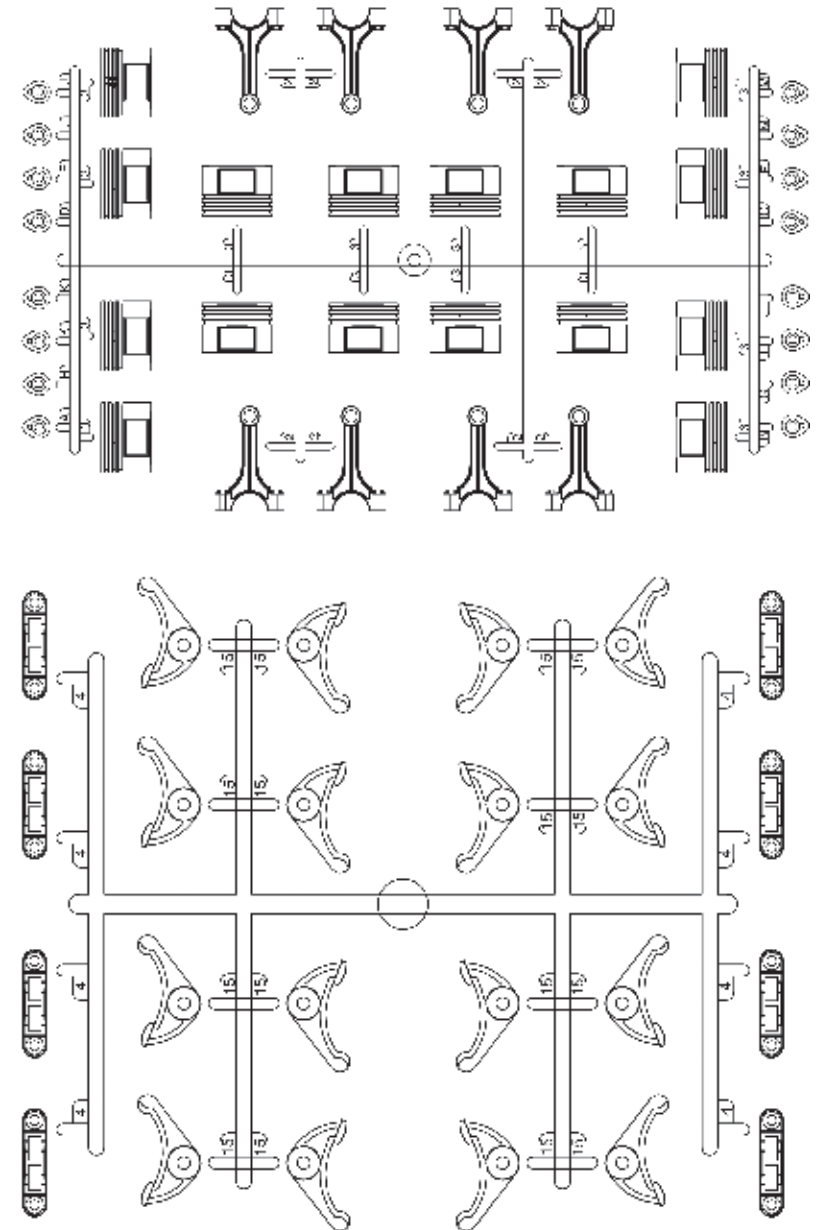

PARTS LIST

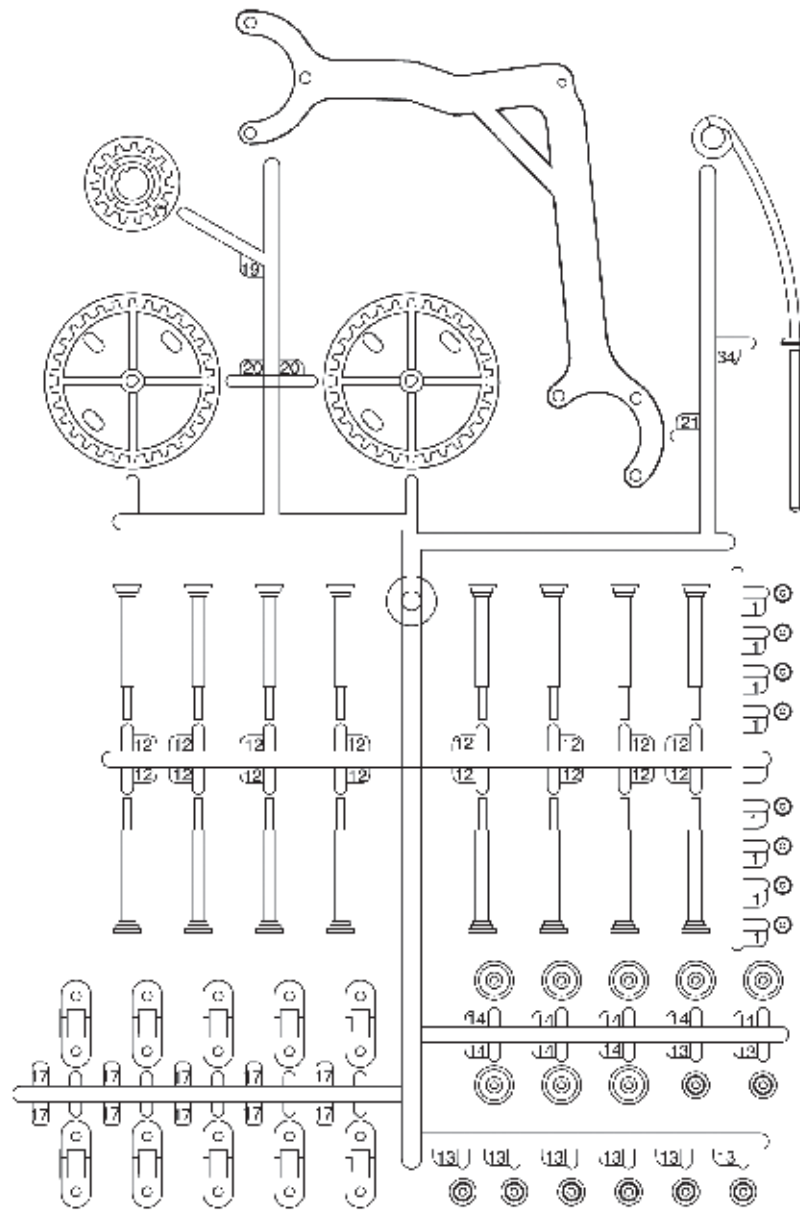

PARTS LIST

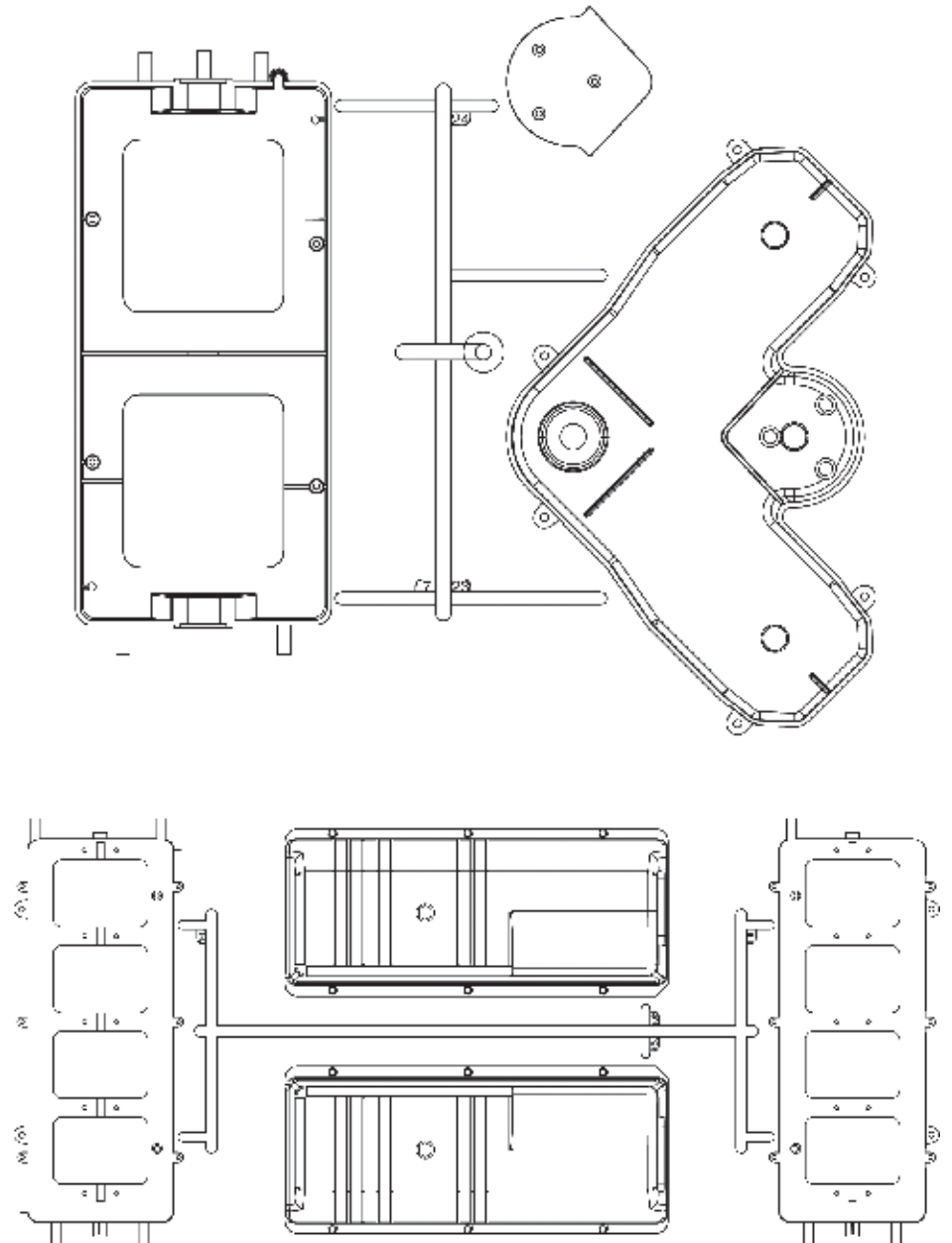

PARTS LIST

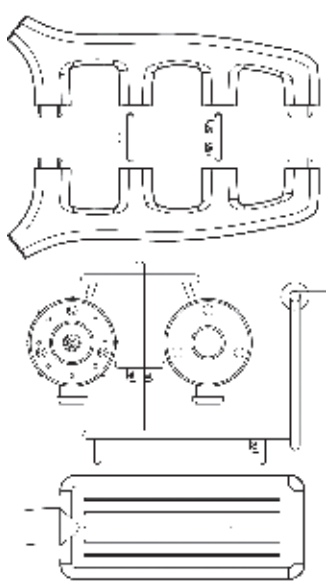
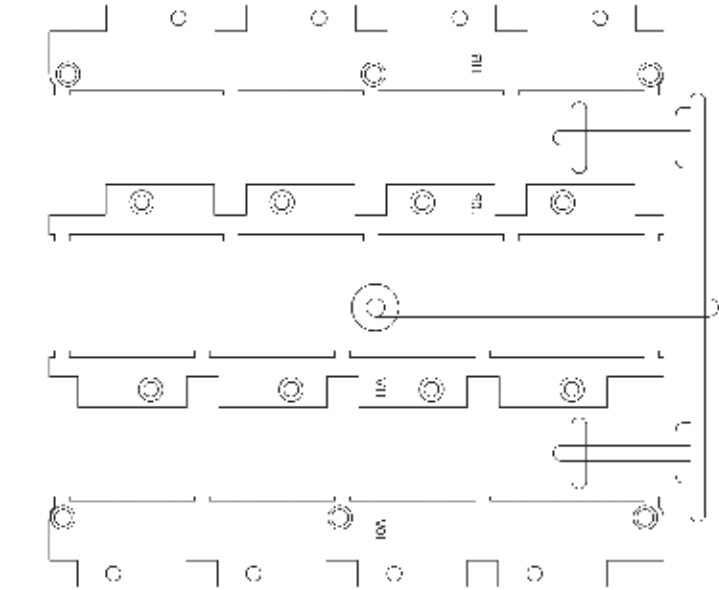

Flywheel



Idler pulley (22)

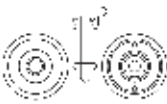

Motor unit



Clutch cover (30)



Distributor

PARTS LIST

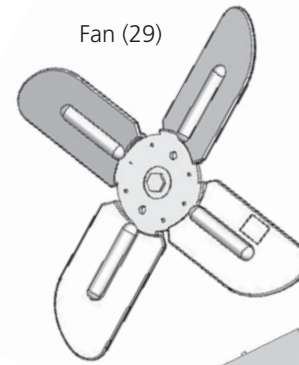

Fan (29)

Inlet manifold (33)

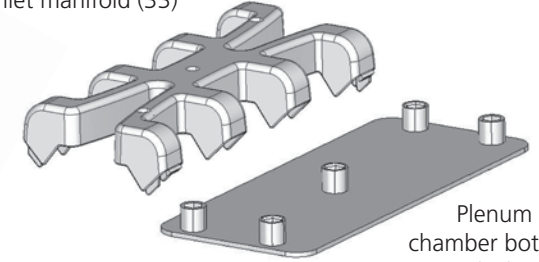

Plenum chamber bottom (31)

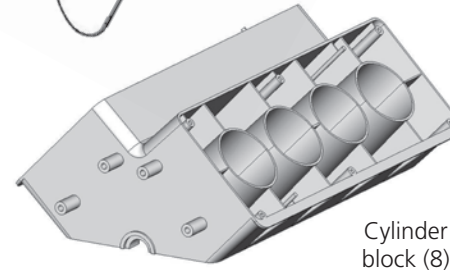

Cylinder block (8)

Lower cylinder head (9A & 9B)

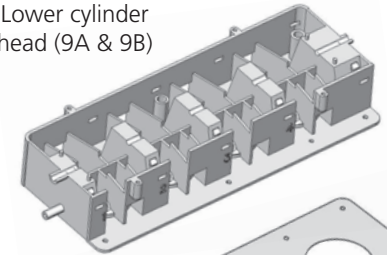

Sump pan (6)

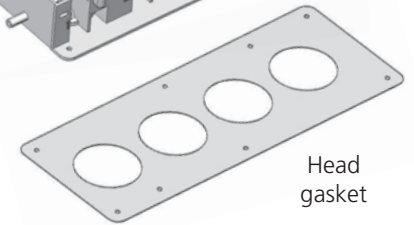
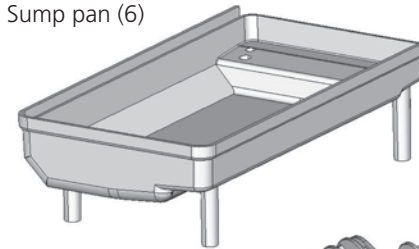

Head gasket

Crankshaft (5)

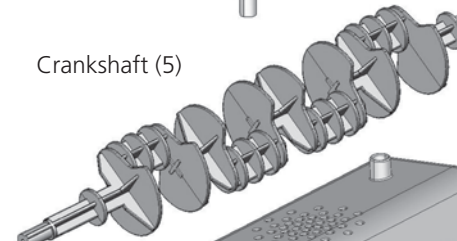

Fan belt

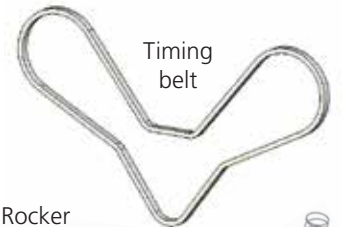

Timing belt

Base

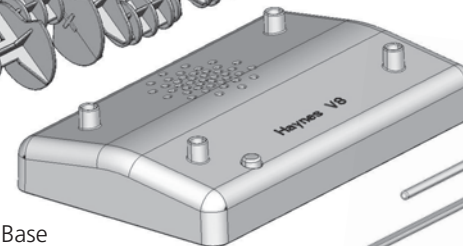

Rocker shaft

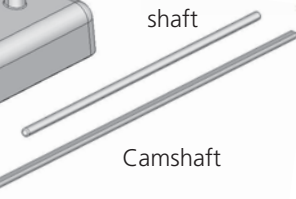

Camshaft

Valve spring

Washer

Screw

ASSEMBLING THE ENGINE

Step 1 - Assemble the pistons and connecting rods

Push a gudgeon (wrist) pin (1) through the small end of a connecting rod (2).

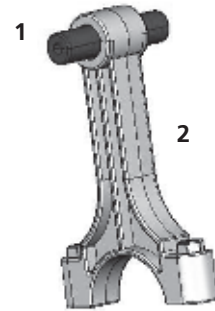

Push two halves of a piston (3) together over the gudgeon (wrist) pin and press together firmly.

Repeat for the other seven piston/rod assemblies.

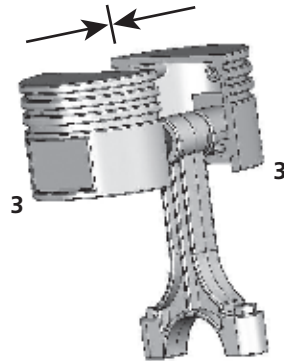

Step 2 - Fit the piston/connecting rod assemblies to crankshaft

The eight connecting rods attach to the crankshaft (5) in the positions shown. In each case, place the connecting rod over the crankshaft, fit a bearing cap (4) and secure with two screws.

Check that the piston/connecting rod assemblies rotate freely around the crankshaft.

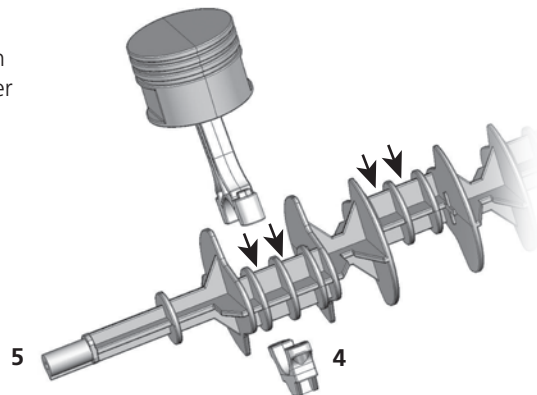

ASSEMBLING THE ENGINE

Step 3 - Fit the lower crankcase to the sump

Place the sump pan (6) over the bottom of the lower crankcase (7) and secure with four screws.

Note: This will only fit one way.

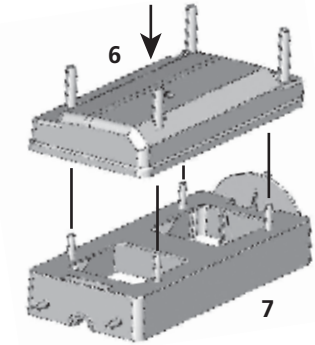

Step 4 - Fit the sump to the base

Fit the base to the sump pan and secure with four screws.

Note: The legs are positioned so that this will only fit one way.

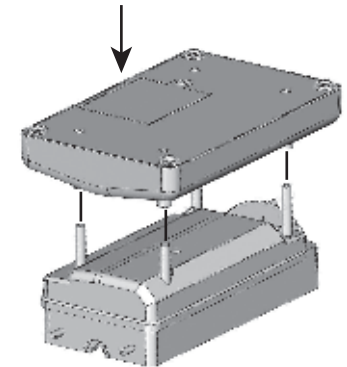

Step 5 - Fit the piston/crankshaft assembly to the cylinder block

Turn the cylinder block (8) upside down. Hold the piston/crankshaft assembly, and starting at one end, gently insert the pistons into the cylinders. You may need to rotate the crankshaft slightly to move the pistons into position. Also note that the two rows of cylinders are offset. The longer (ribbed) end of the crankshaft should be at the end of the block with four studs (the other end has three studs).

Lower the crankshaft until it rests on the bearing surfaces.

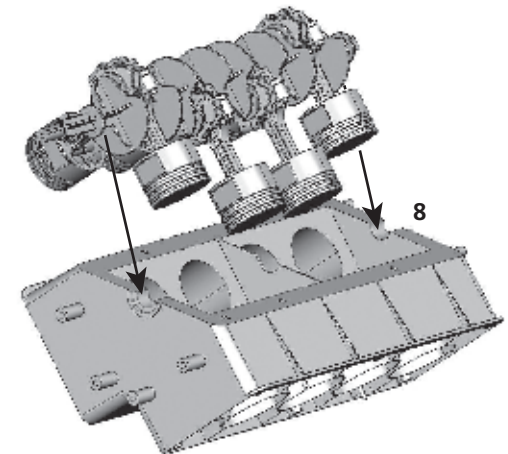

ASSEMBLING THE ENGINE

Step 6 - Fit the cylinder block to the lower crankcase

Turn the cylinder block the right way up, with the crankshaft underneath. Hold the ends of the assembly so the crankshaft stays in position. Fit to the lower crankcase and secure with four screws.

Note: The end of the block with four studs should fit over the end of the lower crankcase that has two studs (see picture).

Gently turn the crankshaft to make sure that it and the pistons move freely.

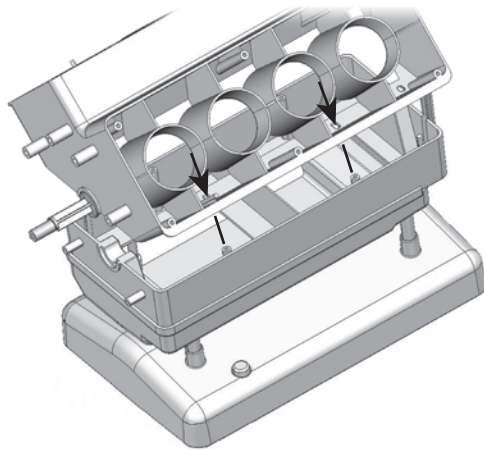

Step 7 - Fit the valves to the lower cylinder heads

Fit two cylinder head plates to each of the lower cylinder heads (9A & 9B). Note that each head uses one narrow plate and one wide plate. The narrow plate fits on the side of the head with the small holes, and the wide plate on the side with the large holes. Each plate has four round studs that face downwards into the head. The plates must be pushed down firmly so they clip into position.

Plates 10A (wide) and 11A (narrow) should be fitted to the cylinder head marked 9A. Plates 10B (narrow) and 11B (wide) should be fitted to cylinder head 9B.

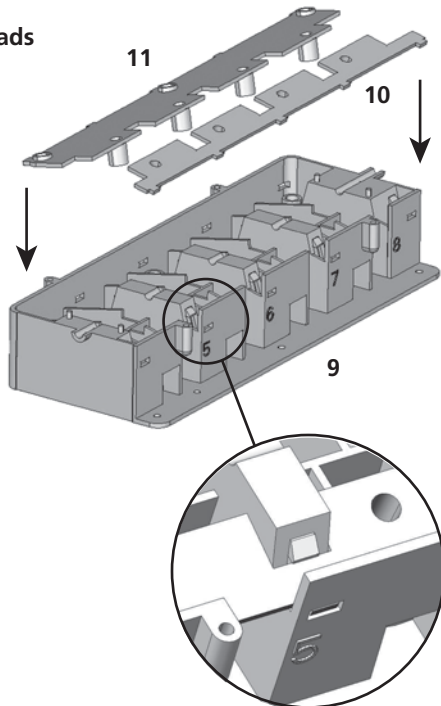

ASSEMBLING THE ENGINE

Remove the 16 valve stems (12), 8 inlet valves (14) and 8 exhaust valves (13) from the carrier frames. Note that the exhaust valves are smaller than the inlet valves. Carefully trim away any excess plastic with a sharp knife.

Fit the exhaust valves to one of the lower cylinder heads. Slide a spring over a valve stem, and then insert the stem into one of the holes in the narrow head plate. Gently push the valve stem, compressing the spring until the end of the stem sticks out the bottom of the head. Carefully push an exhaust valve on to the stem. Note that the end of the valve stem has a step – push the valve until it touches the edge of the step.

DO NOT force the valve – these parts are delicate.

The studs in the wider plate carry the inlet valves. Fit these in the same way as described above for the exhaust valves.

Repeat for the exhaust and inlet valves on the other lower cylinder head. Check that the valves move up and down smoothly.

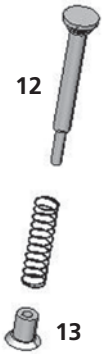
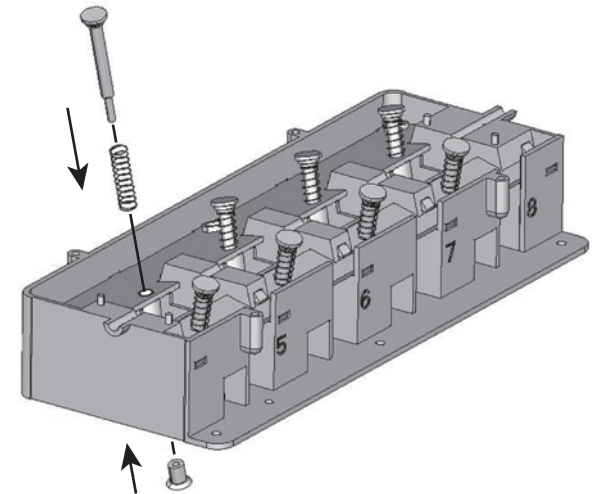

ASSEMBLING THE ENGINE

Step 8 - Fit the rocker arms to the rocker shafts

Remove the sixteen rocker arms (15) from the carrier frame. Slide eight arms on to each of the two, shorter (155 mm) metal rocker shafts exactly as shown in the diagram.

Note: Each successive rocker arm is fitted the opposite way round to the previous arm, and that the right and left rocker assemblies are mirror images. Refer to diagrams below.

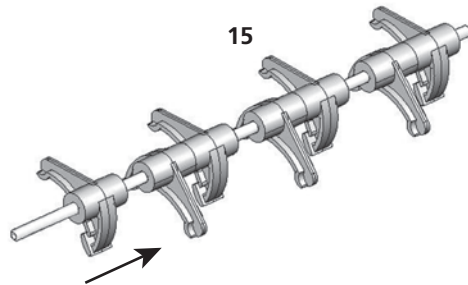

Rockers 'A'

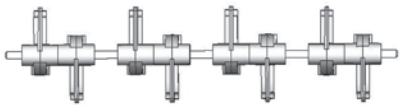

Rockers 'B'

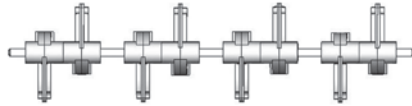

Step 9 - Fit the rocker arm assemblies to upper cylinder heads

Lower the rocker arm assemblies on to the upper cylinder heads (16). Use your fingers to separate the rocker arms into pairs, so they fit into the four holes in the head. Refer to diagram for guidance.

Rockers 'A' should be fitted to upper cylinder head 16A and rockers 'B' to upper cylinder head 16B.

Attach the bearing caps (17) as shown, using two screws for each, and then check that all rocker arms move smoothly.

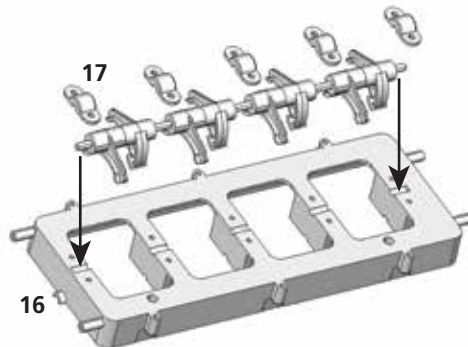

ASSEMBLING THE ENGINE

Step 10 - Fit the cylinder head gaskets

Place the cylinder head gaskets over the cylinder block. There are pegs in the block which match holes in the gasket to ensure correct alignment. Make sure the holes for the pistons in the gasket align with those in the block.

Each gasket will only fit on one half of the block - they are not interchangeable.

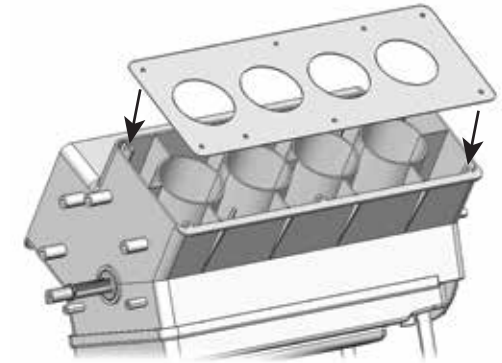

Step 11 - Fit the lower cylinder heads to cylinder block

Fit the lower cylinder heads to the cylinder block. Note that one cylinder head (made from parts all labeled 'A') has the numbers 1-4 engraved on the side and the other (made from parts all labeled 'B') has the numbers 5-8. The pegs in the block fit into holes in the bottom of the heads to ensure correct alignment. The numbers engraved on the side of the blocks should face the outside of the engine. Secure each head with six screws. Refer to diagram.

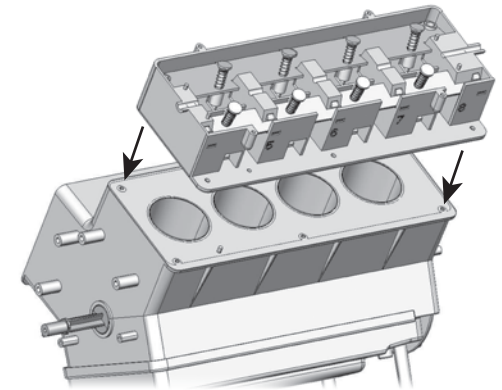

ASSEMBLING THE ENGINE

Step 12 - Assemble the camshafts

Remove the eight cams labeled A–H from the plastic carrier frame. Slide on to one of the camshafts in the order A, B, C, D, etc. Each cam will only fit in one position – there is a flat surface on the inside of each (refer to the enlarged portion of diagram) which matches the flat surface on the camshaft. Please also note the rib on one end of each cam. The cams must be fitted so the ribbed portions all face one way – carefully note the position in the illustration.

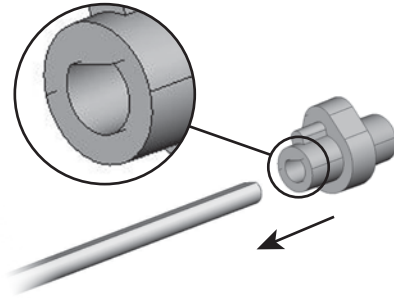

Remove the eight cams labeled J, K, L and M (there are two of each) from the plastic carrier frame. Slide on to the second camshaft in the order JJ, KK, LL and MM. Again, make sure the ribs on the end of the cams all face the same way, as shown in the illustration.

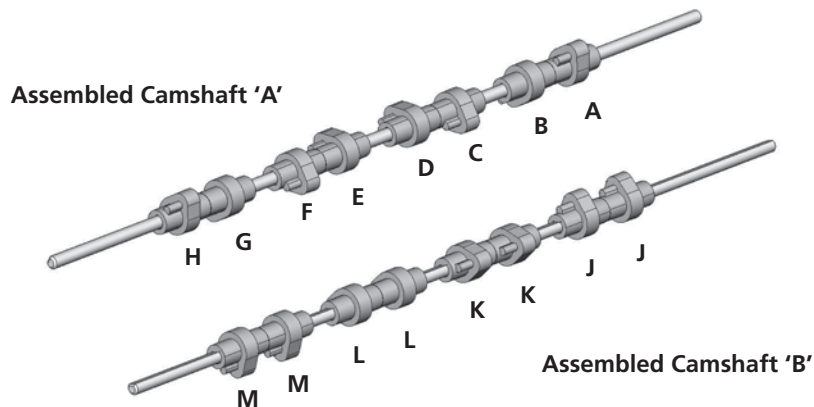

ASSEMBLING THE ENGINE

Step 13 - Fit camshafts to lower cylinder heads

Position the engine so the longer ribbed end of the crankshaft is on your left. Cylinder head 'B' (with the numbers 5-8 on the side) should be nearest to you.

Hold the camshaft with cams A-H (assembled camshaft 'A') with cam H on your left and lower on to the cylinder head furthest away from you ('A', with numbers 1-4 on the side). Use your fingers to separate the cams into pairs, so that each pair fits between the bearings in the head. The camshaft should rest in each of the five bearing surfaces. The ribs on the cams should all point towards the left.

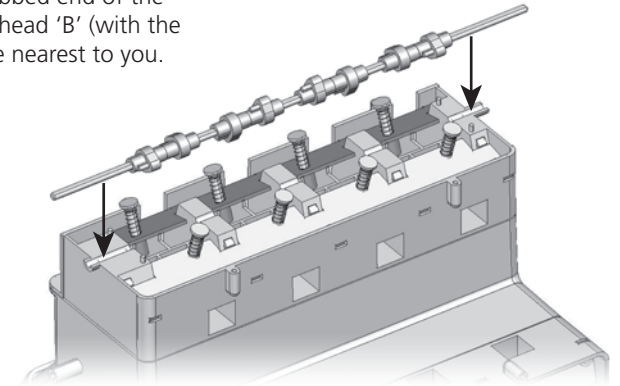

Step 14 - Fit upper cylinder heads to lower cylinder heads

Fit the upper cylinder head assembly 16A to the lower head 9A. Be careful that the longer arms of the rockers match the position of the valves – the ends of the rockers must be positioned over the tops of the valve stems. Note also that one end of the head assembly has two lugs that are more widely spaced. This end should be positioned over the longer, ribbed end of the crankshaft. Secure the head assembly with four screws.

Repeat steps 13 and 14 with the other camshaft. Cam M should be on your left with the ribs all pointing the same way.

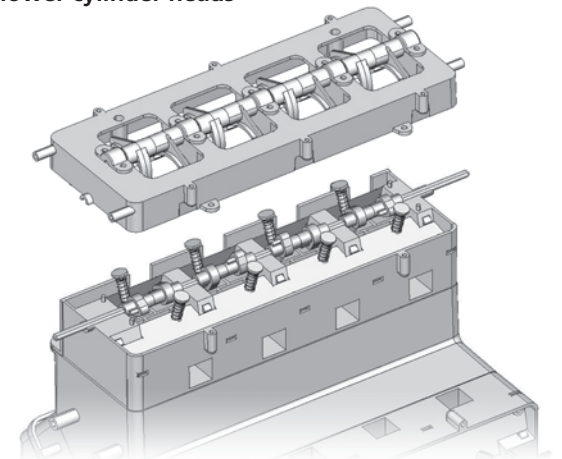

ASSEMBLING THE ENGINE

Step 15 - Fit rocker covers

Fit the rocker covers (18A & 18B) to the tops of the heads using six screws for each rocker cover.

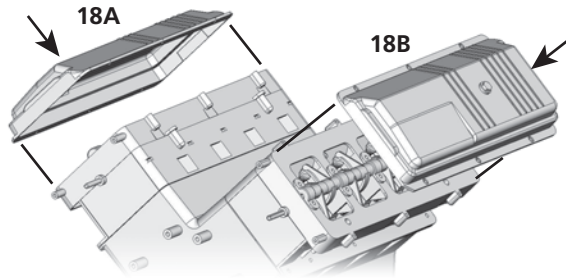

Step 16 - Fit crankshaft sprocket

Push the crankshaft sprocket (19) on to the longer ribbed end of the crankshaft with the toothed side facing away from the engine. There is a slot in the sprocket that matches a rib on the crankshaft; turn the sprocket until it slides on smoothly.

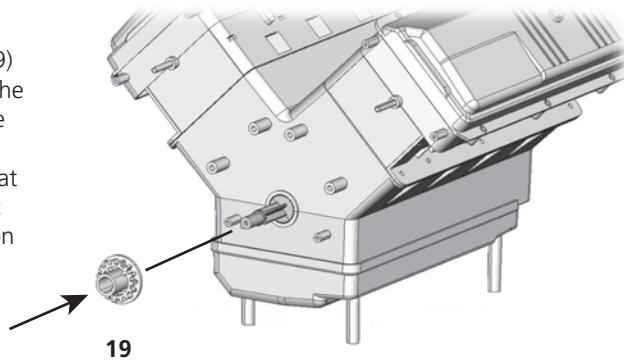

Step 17 - Fit camshaft sprockets

Push the camshaft sprockets (20) on to the ends of the camshafts, again making sure that the toothed sides face away from the engine. The flat in the hole in each sprocket lines up with the flat on the camshafts.

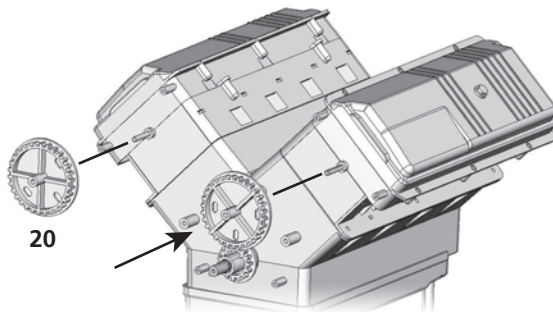

ASSEMBLING THE ENGINE

Step 18 - Fit timing belt and idler pulleys

The next steps are easiest if the engine is held between your legs, with the front of the engine facing upwards.

Rotate the crankshaft until number 4 piston is at top-dead-centre (at its highest position).

Fit the timing tool (21) to the crankshaft and camshaft sprockets. You will need to rotate the camshaft sprockets until the timing tool fits in the holes as shown.

Fit the upper two and right-hand idler pulleys (22). Fit the timing belt to the left-hand camshaft sprocket, and then while maintaining gentle tension, thread under the upper two idler pulleys, around the right-hand camshaft sprocket, and over the right-hand idler pulley. Finally, pass the belt around the crankshaft sprocket (note that the belt passes over the two lugs next to the sprocket), and while pushing the belt upwards, fit the left-hand idler pulley (so the belt passes over it). Carefully put to one side.

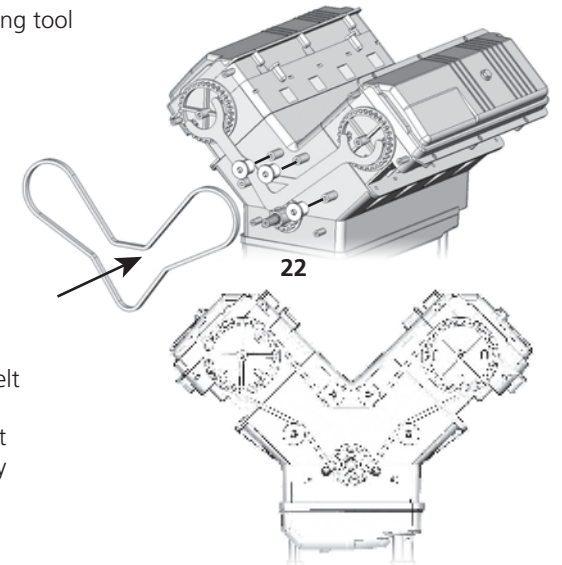
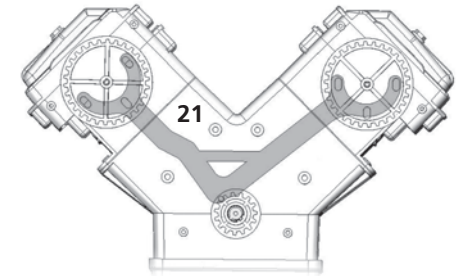

Step 19 - Fit timing belt cover

Push the timing belt cover back plate (24) on to the timing belt cover (23).

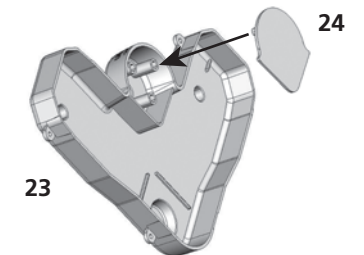

ASSEMBLING THE ENGINE

Step 19 - Fit timing belt cover (continued)

Remove the timing tool, taking care not to dislodge the belt and pulleys. Attach the timing belt cover to the front of the engine and secure with six screws.

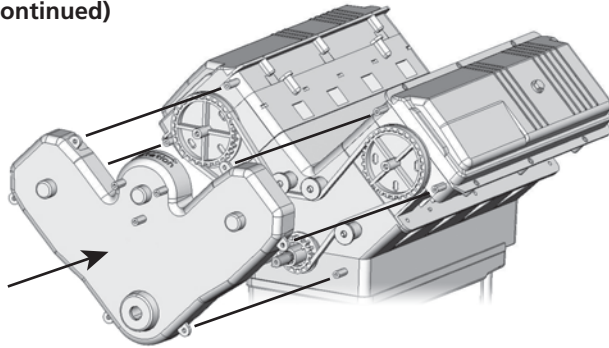

Step 20 - Fit water pump

Assemble the front and back of the water pump (25 & 26), and then fit to the studs on the front of the timing belt cover. Secure with three screws.

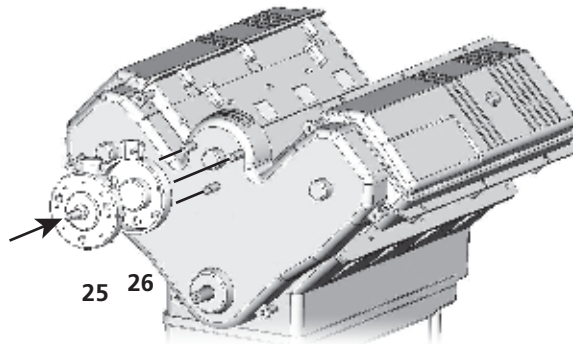

Step 21 - Fit crankshaft pulley

Fit the crankshaft pulley (27) to the end of the crankshaft. The slot in the pulley must line up with the rib on the crankshaft in order to slide into position. Secure the pulley with a single screw and washer.

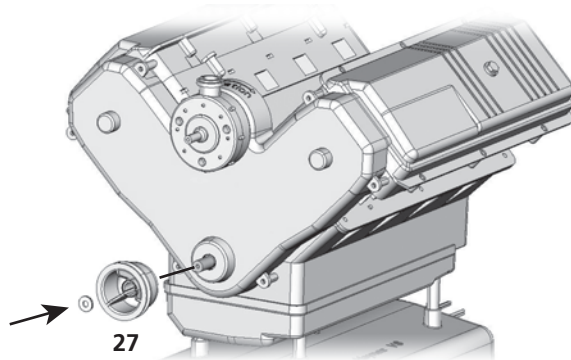

ASSEMBLING THE ENGINE

Step 22 - Fit fan pulley, fan and belt

Fit the fan pulley (28) to the shaft on the front of the water pump. Fix the pulley to the pump using a single screw and washer. Attach the fan (29) to the fan pulley using two screws.

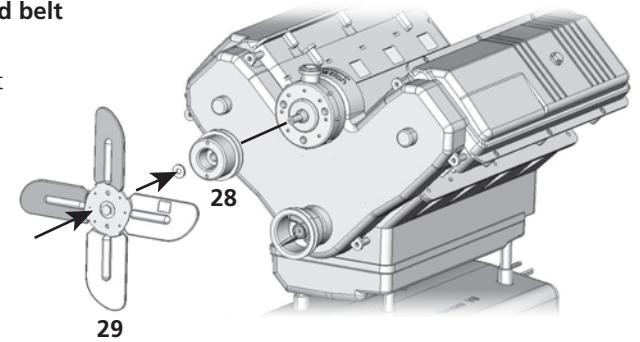

Note: The raised ribs on the fan blades face outwards.

Carefully loop the fan belt over the fan blades so that it rests on the fan belt pulley (the toothed side of the belt should be against the pulley). Pull the other end down and loop it over the crankshaft pulley.

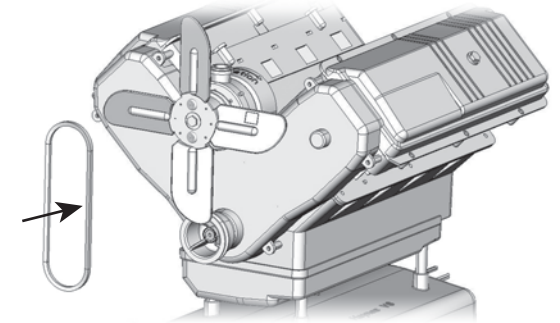

Step 23 - Fit the batteries

Turn the engine upside down. Remove the screw securing the battery compartment cover. Open the compartment and fit 3 AA batteries, taking care to match the + and - markings on the batteries to the markings on the illustration. Replace the cover and turn the engine the right way up.

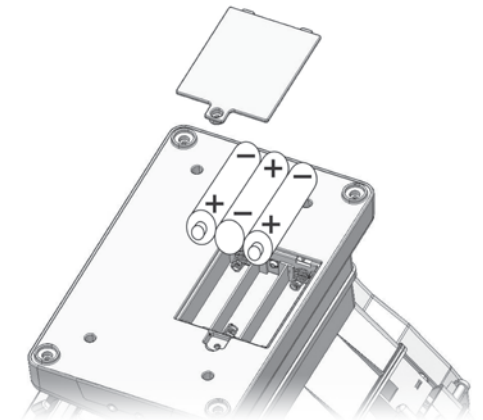

ASSEMBLING THE ENGINE

Step 24 - Fit flywheel

Fit the flywheel to the other end of the crankshaft. The toothed part of the flywheel should be positioned furthest away from the end of the engine.

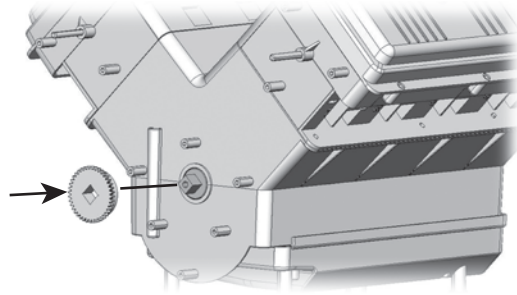

Step 25 - Position pistons

Gently turn the crankshaft by hand so that No 4 piston (see cylinder number markings on outside faces of cylinder heads) moves to its highest position (the "Top-Dead-Centre" or "TDC" position). The flat surface on the camshaft should be facing downwards; if it is facing upwards, continue to rotate the crankshaft until No 4 piston reaches its next TDC position.

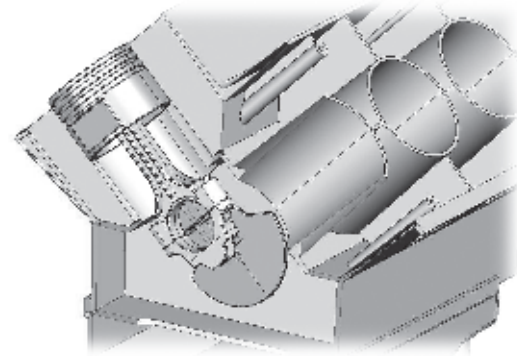

Step 26 - Fit distributors

Fit the distributors to the ends of the camshafts, with the wires positioned at the bottom. One distributor is marked "1-4", which fits to the end of the right-hand cylinder head and the other is marked "5-8", which fits to the end of the left-hand cylinder head. The flat surface in the hole of each distributor fits over the flat surface on the camshafts. Slide the distributors on to the camshafts and rotate until the wires are positioned at the bottom as shown. Insert three screws into the corresponding lugs in the cylinder heads but do not tighten them.

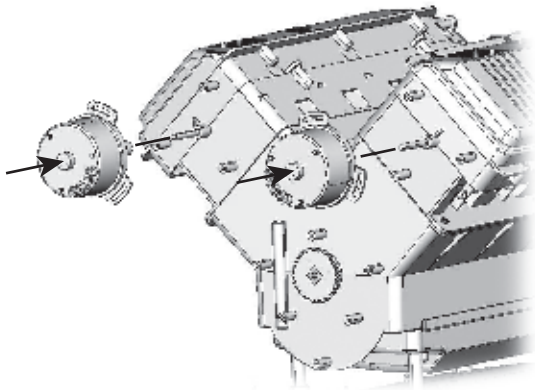

Insert the plug from the distributor wires into the base.

ASSEMBLING THE ENGINE

Step 27 - Adjust ignition timing

Make sure the No 4 piston is still at the top-dead-centre position. Follow the wire from the "4" marked on the distributor to the bulb (spark plug). Adjust the ignition timing as follows: press the red start button on the base and gently turn the "1-4" distributor until the bulb is illuminated. Carefully tighten the three screws to secure the distributor.

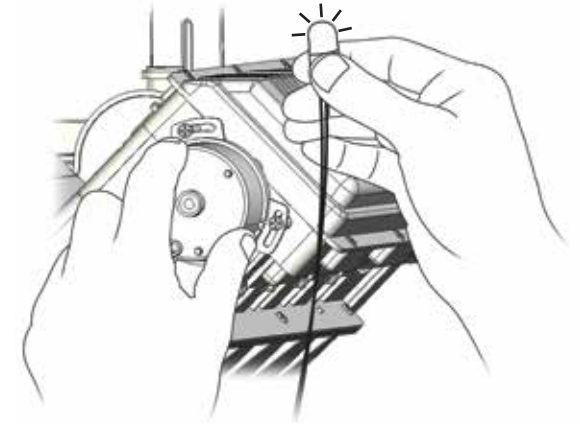

Turn the flywheel anti-clockwise by 90 degrees (a $\frac{1}{4}$ turn) until No 8 piston is at the top-dead-centre position. Using the wire from the "8" marked on the other distributor, press the red start button and then turn the "5-8" distributor until the bulb is illuminated. Carefully tighten the three screws to secure the distributor.

Step 28 - Fit spark plugs

Fit the spark plugs into the corresponding holes in the cylinder heads, following the wires from the markings on the distributor.

Note: The wires are different lengths, with those for cylinders 1 and 8 being the shortest and those for 4 and 5 being the longest.

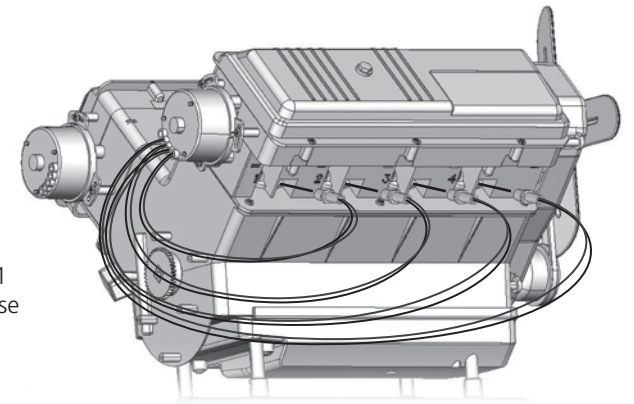

ASSEMBLING THE ENGINE

Step 29 - Fit electric motor

Slide the motor unit into position over the flywheel, making sure that the gears on the motor and flywheel engage. The three mounting holes on the motor unit should line up with the studs on the engine. Secure with three screws.

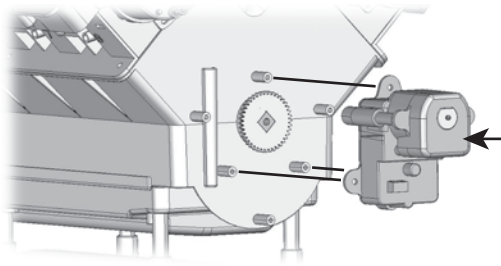

Step 30 - Fit clutch cover

Feed the wire from the motor unit through the hole in the clutch cover (30). Fit the clutch cover to the engine and secure using three screws.

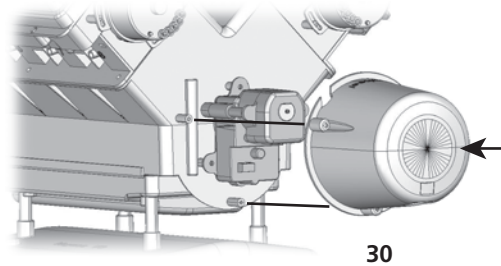

Step 31 - Fit inlet manifold assembly

Assemble the top and bottom parts of the plenum chamber (31 & 32) and then attach to the inlet manifold (33). These parts will only fit together one way – check that the hole in the centre of each part is aligned. Secure with three screws inserted through the underside of the inlet manifold. Push the inlet manifold assembly into the holes in the engine as shown, with the inlet for the plenum facing the rear of the engine.

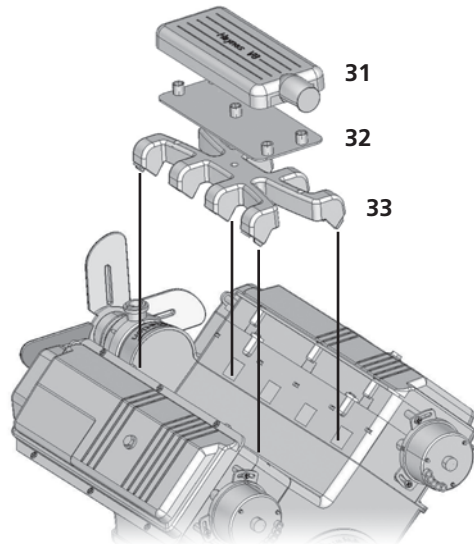

ASSEMBLING THE ENGINE

Step 32 - Fit dipstick

Slide the dipstick (34) into the hole in the engine, next to the clutch cover.

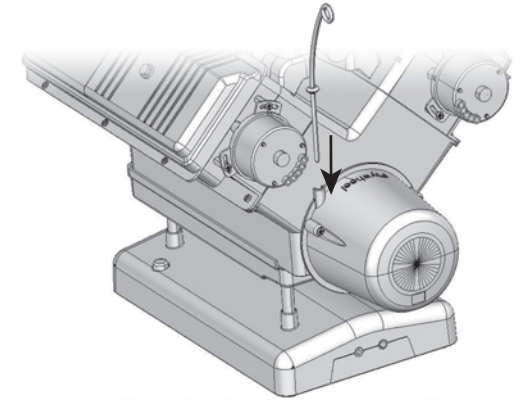

Step 33 - Fit exhaust manifolds

Push the exhaust manifolds (35) into the holes on the outside of each cylinder head, making sure that they face the rear of the engine.

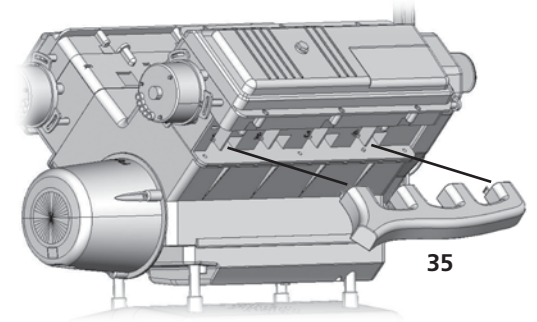

Step 34 - Attach sticker to base

Peel the self adhesive label from its backing and apply to the base as shown.

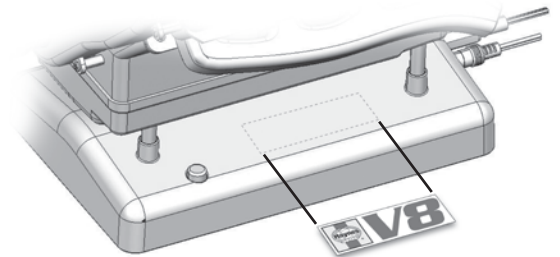

Step 35 - Starting the engine

Plug the motor wire into the base. Press the red "Start" button – the engine will run for approximately 30 seconds.

HOW AN ENGINE WORKS

Basic Principles

To explain how a full-size car engine works, we'll use a simplified version of a real engine - our model engine in fact. You can switch on your finished model as you read this explanation and it will help you to understand how a real engine works.

The crankshaft is called a crankshaft because it is a 'cranked' shaft – the shaft has four cranked sections and the piston/connecting rod assemblies connect to these cranked sections. As the crankshaft turns, the cranked sections rotate around the centreline of the crankshaft and this allows the pistons to move up and down as the crankshaft turns.

When the piston moves down, it pushes the connecting rod down, which pushes against the cranked part of the crankshaft, making the crankshaft rotate. This converts the up-and-down movement of the piston into the turning movement of the crankshaft.

The engine's crankshaft drives the transmission, which includes various different components connected together whose job it is to drive the car's wheels, making the car move.

Now let's look at how the engine works in more detail. We'll look at just one cylinder of the engine. A cylinder is the hollow cylinder inside the engine in which one piston moves up and down. The piston has seals, called piston rings, around its edge, which aren't shown on our model and these seals stop gases passing round the sides of the piston. Our model has eight cylinders.

When you turn the engine to start the car, the starter (a powerful electric motor, powered by the car's battery) turns the crankshaft, moving the pistons up and down.

As a piston moves down from its highest position inside the cylinder (called 'Top Dead Centre' or 'TDC'), a mixture of fuel and air is sucked into the space inside the cylinder above the piston. This is called the **intake** stroke.

The starter continues to turn the crankshaft and, as the piston moves back up towards the top of its cylinder, the fuel/air mixture is compressed (squashed) in the space above the piston. This is called the **compression** stroke.

As the piston reaches its highest point, a spark plug creates a spark above the piston and this spark ignites the fuel/air mixture, causing a small controlled explosion above the piston. The explosion pushes the piston downwards and this is called the **power** stroke.

Once the piston has reached its lowest point, it starts to move back up its cylinder, pushing the burnt gases out through the top of the cylinder. This is called the **exhaust** stroke.

So, the engine has four strokes; intake, compression, power and exhaust, or 'suck', 'squeeze', 'bang' and 'blow' to make it simpler. These four strokes make up the 4-stroke cycle.

HOW AN ENGINE WORKS

The fuel/air mixture flows into the space above the piston, called the combustion chamber. The mixture flows in through a small hole which is opened and closed by the inlet valve. The burnt gas flows out of the cylinder through another hole which is opened and closed by the exhaust valve. The valves are normally held closed by springs, but as the engine turns the valves are pushed open in the correct order by the rocker arms, which are moved by the camshaft. The rocker arm pushes the valve down against its spring and, as the rocker moves up, the spring pushes the valve closed.

4-stroke cycle

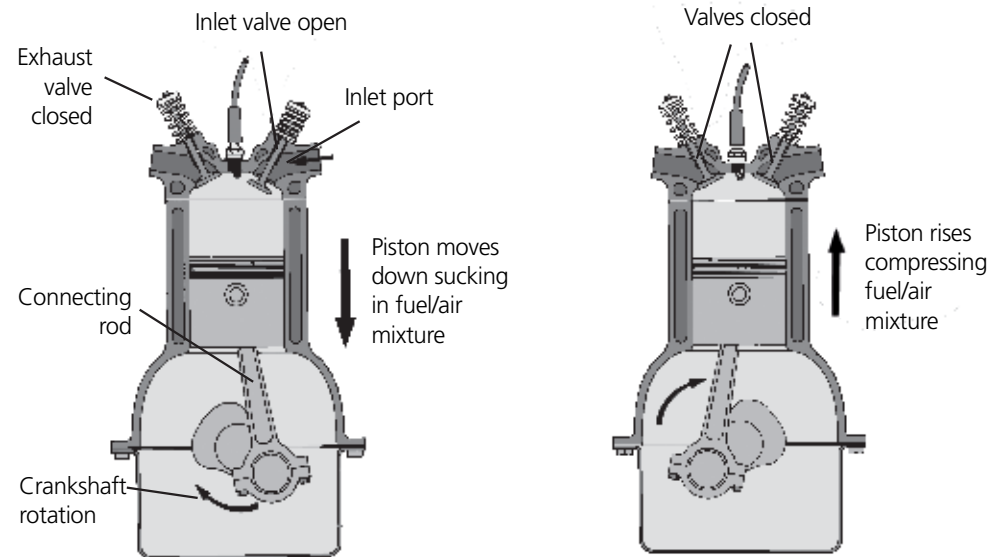

The 1st stroke (intake)

The piston starts off at the top of the cylinder. The exhaust valve is closed and the inlet valve is open. As the crankshaft turns and the piston moves down inside the cylinder, fuel/air mixture is sucked in through the inlet valve. When the piston reaches its lowest point inside the cylinder, the cylinder is filled with fuel/air mixture and the inlet valve closes. This is the end of the intake stroke.

The 2nd stroke (Compression)

At the start of the compression stroke, the piston is at its lowest point inside the cylinder and the inlet and exhaust valves are closed. The crankshaft continues turning and the piston moves upwards. As the piston moves upwards it squeezes (compresses) the fuel/air mixture and this increases the temperature of the mixture very quickly. When the piston reaches its highest point the mixture is fully compressed and this is the end of the compression stroke.

HOW AN ENGINE WORKS

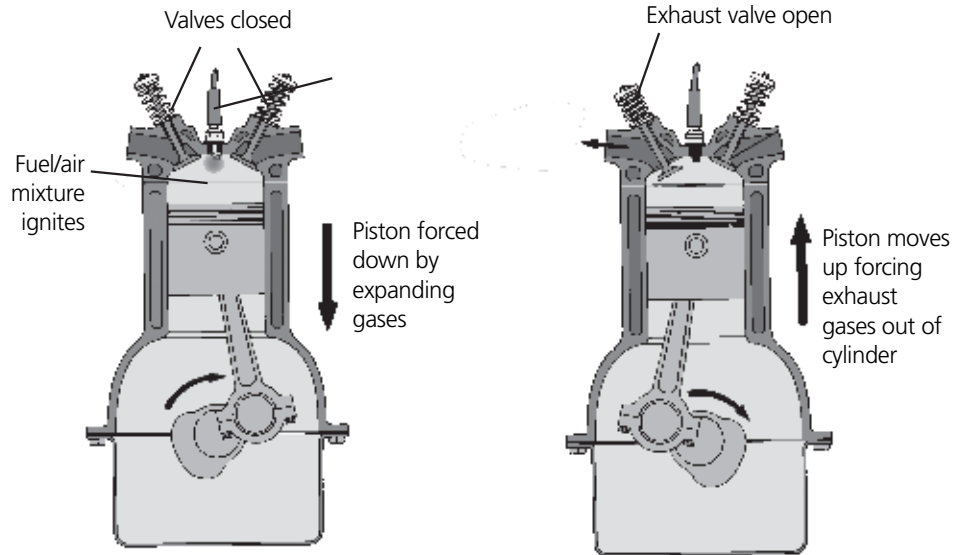

The 3rd stroke (Power)

The very high pressure and temperature inside the combustion chamber cause the fuel/air mixture to break up into very fine particles, like a mist. These are perfect conditions for burning a gas. All that's needed to start the burning (or 'combustion' – a kind of controlled explosion) is a spark. A very high electrical voltage supplied to the spark plug causes a spark to jump across the gap at the end of the spark plug. This ignites the fuel/air mixture and starts the combustion. The force of the controlled explosion and the expanding gases forces the piston downwards, which pushes the crankshaft round. During the power stroke, three things happen to the fuel/air mixture – it ignites, combusts (burns) and expands. The expansion of the gas pushes the piston down, which transfers power to the crankshaft. When the piston reaches its lowest point inside the cylinder this is the end of the power stroke.

The 4th stroke (Exhaust)

As the piston starts to move up inside the cylinder again, the exhaust valve opens to allow the burnt (exhaust) gas to escape from the cylinder and as the piston moves up the cylinder it pushes the gas out through the exhaust valve. As the piston reaches the top of the cylinder the exhaust valve closes, the exhaust stroke ends and the 4-stroke cycle begins again with another intake stroke.

HOW AN ENGINE WORKS

Multi-cylinder engines

So far, we've explained how the engine works by describing what happens in one cylinder. A car engine will actually have more than one cylinder – anything from two (quite rare) to 16 (in the most expensive high-performance cars), as described in the Introduction at the front of this manual. Our model engine has eight cylinders. To make the engine run smoothly, the spark plugs fire in a regular order called the 'firing order' and for our model, the firing order is 1-5-3-7-4-8-2-6. You can see this on the model engine by watching the spark plugs fire – No 1 cylinder is at the rear of the right-hand cylinder bank.

The model engine

You can see how the 4-stroke cycle works by starting your model engine and watching how the components inside move. Watch how the camshaft and rockers move the valves as each piston moves up and down inside its cylinder. If you watch the piston in one cylinder, you should be able to recognise the four strokes – watch the valves and see if you can tell which stroke is which.

Remember that:

- On the intake stroke the piston moves down, the inlet valve is open and the exhaust valve is closed.
- On the compression stroke, the piston moves up and the inlet and exhaust valves are closed.
- On the power stroke, the piston moves down and the inlet and exhaust valves are closed.
- On the exhaust stroke, the piston moves up, the inlet valve is closed and the exhaust valve is open.
- The exhaust valves are on the exhaust-manifold side of each cylinder head, and the inlet valves are on the inlet manifold/plenum chamber side (in the middle of the engine).

You'll notice that all eight cylinders in the model engine are on different 'strokes' – watch how the pistons move as the crankshaft turns and you'll see that the pistons on each cylinder bank move in pairs and, when two of the pistons are at the tops of their cylinders, the other two are at the bottom. Even though two of the pistons may be at the tops of their cylinders, the pistons will be on different strokes – one will be about to move down at the start of its intake stroke and the other will be about to move down at the start of its power stroke. You can tell which piston is about to start its power stroke because the spark plug will fire (the red bulb will light) in the cylinder head above the piston which has just reached the end of its compression stroke and is just about to start its power stroke.

HOW AN ENGINE WORKS

What does the ignition system do?

The ignition system produces the sparks which are used to ignite the fuel/air mixture in an engine (diesel engines don't have an ignition system). The ignition coil changes the low-voltage electricity from the battery into high-voltage electricity which is sent along the HT (High Tension) leads to the spark plugs. The spark plugs are screwed into the cylinder head and produce sparks inside the combustion chambers.

What does the fuel injection system do?

All modern engines are fitted with a fuel injection system.

There are two basic types of fuel injection system, single-point and multi-point. A single-point fuel injection system has a single fuel injector which sprays fuel into the inlet manifold where it's mixed with air before passing through the engine's inlet valves into the cylinders. A multi-point fuel injection system works in exactly the same way, except that a separate fuel injector is used to fuel each cylinder.

What do emissions-control systems do?

When the fuel/air mixture is burnt inside the engine, exhaust gases are produced. The exhaust gases pass through the car's exhaust system out into the atmosphere, causing pollution. These gases are known as exhaust emissions and all engines have emissions-control systems fitted to reduce harmful pollution.

What does an engine management system do?

An engine management system is controlled by an electronic control unit (ECU) which is connected to various sensors and actuators fitted around the engine. The sensors monitor the engine operating conditions and produce electrical signals which are sent to the ECU. The ECU processes all the information from the sensors and is able to tell exactly what conditions the engine is running under. The ECU then sends signals to the ignition, fuel injection and emission control systems to control the engine.

An engine management system allows very fine control of the engine and the ECU makes sure that the engine operates as efficiently and smoothly as possible, which means that it uses less fuel and causes less pollution.

Why does an engine need oil?

Oil is the engine's blood. The engine needs oil for two reasons – to reduce the friction between the moving parts and to help keep the engine cool.

Some of the metal components inside the engine move at a very high speed, very close together, and they rely on a thin film of oil between them to prevent the components from

HOW AN ENGINE WORKS

rubbing together. If the components rub together they will very quickly overheat and seize up, which can wreck the engine.

When the engine is stopped, the oil is stored in a tray called the sump, bolted to the bottom of the cylinder block. When the engine is running, the oil is pumped from the sump to all moving parts of the engine through small passages in the cylinder block and cylinder head. The oil pump is driven by the engine, usually from the crankshaft. As the oil circulates through the engine, it picks up tiny particles of dirt and, as the engine wears, tiny particles of metal, which would eventually damage the engine's moving parts. The oil passes through an oil filter which catches these small particles; the oil filter is one of the most important parts of the engine. Eventually, the oil filter starts to clog up and the oil can't flow through as easily, so it must be changed whenever the engine oil is changed at the recommended service intervals.

The amount of oil inside the engine can be checked using a 'dipstick' – if the oil level is low, it can damage the engine very quickly. If the oil level is checked often and the oil and filter are changed at the recommended intervals, the engine will stay healthy.

Why does the engine have a cooling system?

The cooling system is vital because it stops the engine overheating. It also keeps the engine at the best temperature for it to work efficiently, which means that it will use less fuel and will produce less harmful exhaust emissions.

The coolant is pumped around the passages inside the engine by the coolant (water) pump, collecting heat from the engine components as it flows through. The hot coolant then passes from the engine to the radiator (mounted at the front of the car under the bonnet), where the air is forced through the radiator as the car moves forward cooling the hot coolant. The cooling fan draws cool air over the radiator when the speed of the car is too low (or if the car is stopped), or if the air temperature is too high to give sufficient cooling. The coolant pump is... usually driven by a belt, sometimes by the timing belt and sometimes by a separate auxiliary (or 'fan') belt.

What's the difference between a normal engine and a diesel engine?

Diesel engines use diesel fuel instead of petrol (gasoline), and the biggest difference is the way that the fuel burns. Most engines need a spark plug to ignite the fuel with a spark, but in a diesel engine there's no spark plug, and the fuel ignites by itself due to the high pressure and temperature inside the combustion chamber.

Because diesel engines need a high temperature to ignite the fuel, when they're first started from cold they use 'glow plugs' to heat the fuel/air mixture to a high enough temperature to ignite. Generally, diesel engines use less fuel than petrol engines, and they produce less pollution.

So, now you have a good idea of how an engine works.

KEEPING A CAR AND ITS ENGINE HEALTHY

There are a few simple checks that can be done once a week to keep a car and its engine in good condition. These checks will only take about ten minutes and the handbook that was supplied with the car will explain how to carry these out.

Weekly checklist:

- Check the engine oil level
- Check the engine coolant level
- Check the brake fluid level
- Check the windscreen washer fluid level, and check that the washers and windscreen wipers work
- Check that the wiper blades are in good condition
- Check the tyre pressures and check that the tyres aren't damaged or worn
- Check the power steering fluid level, if the car has power steering

REDUCING POLLUTION AND SAVING ON FUEL BILLS

Using less fuel saves money and also reduces pollution, and it's easy to do both by bearing in mind a few simple points. All the following points increase the amount of fuel used and so increase pollution.

- Towing a trailer or caravan and carrying heavy loads
- Driving the car with a roofbox or roof bars fitted
- Lots of short journeys
- Driving with low tyre pressures

BASIC ENGINE TERMS

Here's a list of common terms connected with a car engine, with simple explanations of what they mean.

Air filter – A paper or foam filter that removes dirt from the air that's sucked into the engine.

Alternator – An electrical generator driven by the engine. It provides electricity for the car's electrical system when the engine's running, and to charge the battery.

Antifreeze – A fluid that's added to water to produce engine coolant. The antifreeze stops the coolant freezing in cold weather and prevents corrosion inside the engine.

Battery – A 'reservoir' that stores electricity. Provides the power to start the engine and power for the electrical systems when the engine is stopped, and is charged by the alternator when the engine's running.

Bearing – A metal or other hard-wearing surface that another part moves against. A bearing is designed to reduce friction and wear and is usually lubricated with oil or grease.

Big-end – The lower end of a **connecting rod** attached to the engine's **crankshaft**. It has a bearing and transmits the movement of the connecting rod to the crankshaft.

Bore – A term used to describe the diameter of a cylinder in an engine.

Breather – An opening or valve that allows air or fumes out of the engine, or fresh air into the engine.

Cam belt – See **Timing Belt**.

Cam follower (tappet) – A component fitted between the **camshaft** and a valve to operate the **valves**.

Camshaft – A rotating shaft driven from the **crankshaft**, with cams that push the valves open.

Catalytic converter – A device fitted in the exhaust system that reduces the amount of

harmful gases released into the atmosphere.

Clutch – A part that allows two separate rotating components to be coupled together smoothly, without the need for either component to stop moving.

Combustion chamber – A shaped area into which the fuel/air mixture is compressed by the **piston** and where the mixture is ignited. The combustion chamber may be in the **cylinder head**, or sometimes in the top of the **piston**.

Compression ratio (CR) – A term to describe the amount by which the fuel/air mixture is compressed as a **piston** moves from the bottom to the top of its travel.

Connecting rod (con rod) – A metal rod in the engine connecting a **piston** to the **crankshaft**. The connecting rod transfers the up-and-down motion of the piston to the crankshaft.

Coolant – A mixture of water and **antifreeze** used in a car's engine cooling system.

Coolant (water) pump – A pump driven by the engine that pumps the coolant around the cooling system.

Cooling fan – Electric or engine-driven fan mounted at the front of the engine compartment and designed to cool the **radiator**.

Crankcase – The area of the **cylinder block** below the **pistons**, which houses the **crankshaft**.

Crankshaft – A cranked metal shaft that changes the up-and-down motion of the **pistons** and **connecting rods** into a rotary motion.

Cylinder – A metal tube in the engine in which a piston slides.

Cylinder block – The main engine casing, which houses the cylinders, crankshaft, pistons and connecting rods.

Cylinder head – The casing at the top of the engine that houses the valves and valve gear. The cylinder head is bolted to the **cylinder block**.

BASIC ENGINE TERMS

Cylinder head gasket – The gasket that makes a seal between the **cylinder head** and the **cylinder block**.

Dipstick – A metal or plastic rod used to check the engine oil level.

Distributor – A device used to distribute the ignition HT circuit current to the individual **spark plugs**.

DOHC – Double Overhead Camshafts. An engine with two **camshafts**, where one operates the inlet **valves**, and the other operates the exhaust valves.

Drivebelt – A belt, usually made from rubber, used to transmit drive between two pulleys or sprockets. Often used to drive the **camshafts** and engine ancillaries.

Emissions – Harmful substances (gases or particles) released into the atmosphere from a car's engine.

Emissions control – A way of reducing the **emissions** released into the atmosphere.

Engine management system – A system which uses an electronic control unit to control the **ignition system** and **fuel injection system**, improving engine efficiency and reducing emissions.

Exhaust manifold – A ducting used for directing the exhaust gases from the engine's **cylinder head** into the exhaust system.

Fan belt – Another term for a drivebelt.

Fault code – An electronic code stored in the memory of an electronic control unit which gives details of a fault detected by the self-diagnostic system. A diagnostic light on the instrument panel will usually come on to indicate a fault.

Firing order – The order in which the **pistons** in the cylinders of an engine reach their **firing points**.

Firing point – The instant at which the fuel/air mixture in the **cylinder** of an engine ignites in the **combustion chamber**.

Flywheel – A heavy metal disc attached to one end of the **crankshaft** in an engine, used to smooth out the power pulses from the **pistons**.

Four-stroke – A term used to describe the four operating strokes of a **piston** in a car engine.

Fuel injection – A method of injecting a measured amount of fuel into an engine.

Fuel injector – A device used to inject fuel into an engine. Some engines use a single fuel injector, whilst some use one fuel injector for each cylinder of the engine.

Gasket – A material used between two surfaces to give a leakproof joint.

Glow plug – An electrical heating device fitted to a **diesel engine** to help the engine start from cold.

Head gasket (cylinder head gasket) – A gasket fitted to provide a leakproof seal between an engine's **cylinder block** and **cylinder head**.

Ignition coil – An electrical coil that generates the high voltage needed in a petrol (gasoline) engine **ignition system** to fire the **spark plugs**.

Ignition system – The electrical system that controls the spark used to ignite the fuel/air mixture in a petrol engine.

Ignition timing – A measure of the instant in the **cylinder** firing cycle at which the ignition spark (provided by the **spark plug**) happens in a petrol (gasoline) engine.

Inlet manifold – A ducting, usually made of metal or plastic, which directs the air, or fuel/air mixture into the engine's **cylinder head**.

Mixture – The fuel/air mixture burnt by an engine to produce power.

Oil filter – A renewable filter that removes dirt from engine oil.

BASIC ENGINE TERMS

Oxygen sensor (lambda sensor) – Provides information on the amount of oxygen in the exhaust gases. Used to enable the **engine management system** to control the fuel/air mixture.

Piston – Cylindrical component which slides in a close-fitting **cylinder**. The pistons in an engine compress the fuel/air mixture, transmit power to the **crankshaft** through the **connecting rods**, and push the burnt gases out through the exhaust **valves**.

Piston ring – A hardened metal ring that fits in a groove running around a **piston**. The piston ring ensures a gas-tight seal between the piston and the cylinder.

Radiator – A cooling device, usually positioned at the front of the car, through which the hot coolant is passed. As the car moves forward, the airflow cools the coolant in the radiator.

Rocker arm – A lever used in an engine's **valve**-operating mechanism which rocks on a pivot, with one end moved up and down by the **camshaft** and the other end operating a valve.

Spark plug – A device that provides the spark in a petrol (gasoline) engine's **combustion chamber** to ignite the fuel/air mixture.

Starter motor – An electric motor used to start the engine.

Stroke – The total distance travelled by a single piston in a **cylinder** when it moves from the bottom to the top of the cylinder.

Sump – The main reservoir for the engine oil. Bolted to the bottom of the engine.

Tappet – See **Cam follower**.

Timing belt (**cam belt**) – Toothed drivebelt, used to transmit drive from the **crankshaft** to the **camshaft**.

Thermostat – A device that helps the engine to warm up by stopping the coolant from flowing through the **radiator** until a certain temperature is reached.

Top Dead Centre (TDC) – The exact point when a piston is at the top of its **stroke**.

Turbocharger – A device that forces air into the engine. This pushes more fuel/air mixture into the engine and increases the engine's power.

Twin-cam – Abbreviation for twin overhead **camshafts** – see **DOHC**.

Valve – A device that opens and closes to stop or allow gas or liquid to flow.

Valve Clearance – The clearance between the top of a **valve** and the **camshaft**.

Valve lifter – See **Cam follower**.

16-valve – A term used to describe a four-cylinder engine with four **valves** in each cylinder, usually two exhaust and two inlet valves.

Vee-engine – An engine design where the **cylinders** are arranged in two rows, forming a 'V' when viewed from one end. For example, a V8 has two rows of four cylinders each.

NOTES:

NOTES:

NOTES: