

# USER MANUAL



**Model: BD/BOH/10**

Sealed Battery Operated Multi-Sensor Smoke Alarm with 10 Year Life



## INTRODUCTION

BD/BOH/10 is an Multi-Sensor Smoke Alarm which is designed to operate as a standalone unit.

## SPECIFICATION

<b>Power Supply:</b>	Non-Replaceable Lithium Battery
<b>Temperature Ambient:</b>	0°C to 40°C
<b>Detection Type:</b>	Optical Smoke, Fixed Heat Thermistor
<b>Humidity Ambient:</b>	10% to 90% (non-condensing)
<b>Alarm Sound Level:</b>	85 Decibels at 3m
<b>Max Operational Life:</b>	10 Years
<b>Approved by BSI to:</b>	BS EN 14604:2005, BS 5446-2:2003
<b>Associate Standard:</b>	BS 5839-6:2019 GRADE F1

# DIAGRAM

**Fig.1 Back View**

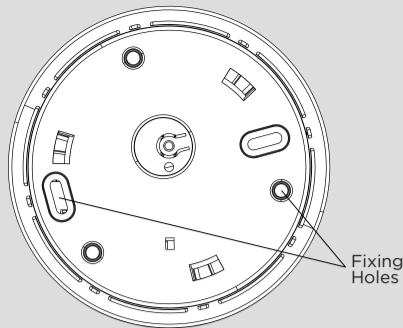

**Fig.2 Front View**  
Alarm unit: Ø 121mm

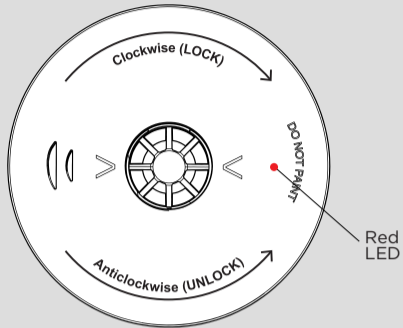

**Fig.3 Side View**

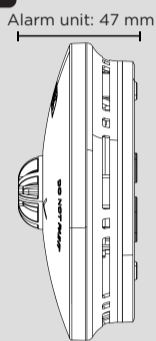

**Fig.4 Installed View**

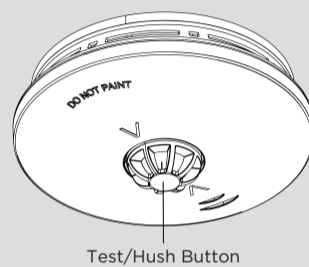

# POSITIONING OF THE ALARM

- A properly designed early warning fire system ensures the alarm is given before the escape routes become blocked with smoke.
- If your dwelling is on a single storey, for minimum protection you should fit an alarm in a corridor or hallway between the sleeping and living areas (incl. Kitchens). Place it as near to the living areas as possible and ensure the audible alarm can be heard when the bedrooms are occupied. See **Figure 7** for examples.
- If your dwelling is multi-storey, for minimum protection one alarm should be fitted at the bottom of the staircase with further alarms fitted on each upstairs landing. This includes basements but excludes crawl spaces and unfinished attics. See **Figure 7** for examples.

**NOTE:** For maximum protection, an alarm should be fitted in every room (except the bathroom). This alarm contains a smoke sensor and a heat sensor, it should be installed in accordance with the smoke alarm guidance in **Figure 7**. This alarm is suitable for open-plan Living/Kitchen/Dining areas but should be installed on the Living/Dining side to eradicate false activations. Having a heat alarm only in this area will increase response time if a fire occurs.

### Ceiling Mounting

- As hot smoke rises and spreads out, it is advisable to mount on a ceiling in a central position. Avoid areas where there is no air circulation. E.g. corners of rooms and keep away from items which may prevent the free flow of air. Place the unit at least 300 mm from any light fitting or decorative object which might obstruct smoke entering the alarm. Keep at least 300 mm away from walls. See **Figure 5**.

### Wall Mounting

- Do not mount tight into the corners. Put the top edge of your smoke alarm between 150 and 300mm below the ceiling. Keep at least 300mm from room corners. See **Figure 5**.

### On a Sloping Ceiling

- In areas with sloping or peaked ceilings install your alarm in accordance with **Figure 6** because "dead air" at the apex may prevent smoke from reaching the unit.

**Fig.6 Positioning the smoke/heat alarm**

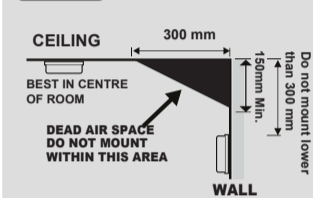

**Fig.7**

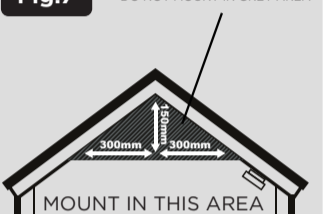

**Fig.8**

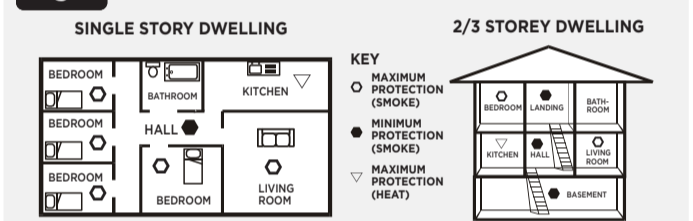

KH 792788  
KH 792789  
BS EN14604:2005  
BS 5446-2:2003

## AVOID THESE LOCATIONS

- Situations where the temperature may fall below 0°C or rise above 40°C for extended periods.
- Humid areas such as **BATHROOMS, KITCHENS, SHOWER ROOMS** where the relative humidity may exceed 90% as vapour will cause false alarms.
- Near a **DECORATIVE OBJECT, DOOR, LIGHT FITTING, WINDOW MOULDING** etc., that may prevent smoke entering the alarm.
- Fume filled environments such as **GARAGES**, exhaust gases may cause false alarms.
- Adjacent to or directly above hot components such as **RADIATORS** or **WALL VENTS** that can affect the direction of air currents.
- In **VERY DUSTY OR DIRTY** environments such as workshops.
- Locate alarm at least 1.5m and route wiring at least 1m away from **FLUORESCENT LIGHT FITTINGS** as electrical 'noise' and/or flickering may affect the alarm. Do not wire into same circuit as fluorescent lights or dimmers.
- Do not locate in **INSECT INFECTED AREAS**, insects and contamination on the alarm sensor can increase its response time.

## INSTALLATION

### Important Safety Notices:

- This alarm should be installed by a competent person.
- The Battery is Non-Replaceable, any attempt to replace the battery may cause electric shock and/or explosion.
- Do not attempt to open the alarm under **ANY** circumstances.

## MOUNTING

Before installing the alarm, it is crucial to thoroughly review the provided instructions. The alarm is composed of two parts: the mount base assembly and the alarm unit. It is recommended to keep the alarm unit protected by a plastic dust cover; and separate it until the building commissioning phase. This phase usually involves activities like sanding, preparing for painting, actual painting, and floor laying.

### Please follow these steps to mount the fire alarm:

- Choose a suitable location on the ceiling that complies with section **POSITIONING OF THE ALARM**.
- Separate the mounting base from the alarm head.
- Locate the mounting plate on the ceiling in its exact final position and mark the location of the screw holes.
- Using a 5mm drill bit, drill the hole locations. Be vigilant of any electrical wiring or pipework in the area.
- Insert the provided wall plugs into the holes and screw the mounting plate to the ceiling. **DO NOT OVER TIGHTEN**.

## DUST COVER

The fire alarm is enclosed in a plastic dust cover for the following reasons:

- To provide protection for the alarm unit from dust during the building construction phase.

Keep the alarm head, while in the dust cover, separate until the building commission phase to prevent dust accumulation and battery degradation.

During the commissioning process, it is necessary to remove the dust cover and securely attach the alarm unit to the mounting base.

## COMMISSIONING

### STEPS TO ACTIVATE THE FIRE ALARM:

- Remove the alarm unit from the dust cover.
- Fill out the 'Date of Installation' label located on the side of the alarm.
- Align the fixing points on the head unit with the plastic lugs on the mounting base.
- Rotate the alarm head Clockwise until it turns no further. The battery activates when twisting into the mounting base.  
**Note:** The battery will activate once the alarm unit is inserted into the mounting base. It is designed to provide a 10-year lifespan during regular operation.
- The alarm is now securely attached to the mounting base, a red flashing **LED** will illuminate every 40-60 seconds to signal normal operation. If any other sequence of flashing **LEDs** occur, refer to the **INDICATION AND ACTION** section of this manual.
- Press and **HOLD** the test button for up to 5 seconds, the alarm will sound within this period.  
**Note:** After the Test/Hush button has been pressed, wait 10 minutes before any additional testing is conducted to avoid any abnormal responses as the smoke alarm is less sensitive to smoke during this period.

### WARNING

In case you encounter frequent false alarms, we recommend relocating the device away from any potential fume sources. If the alarm continues to trigger false alarms even when there is no smoke present, it might require maintenance or cleaning.

## OPERATION

This alarm has a built-in feature to detect the power source. In normal operation, to the guidelines and specification in this instruction manual, the alarm will last for 10 years from the installation date.

The alarm must be replaced after 10 years, sensitive electronic components used within smoke alarms may become less effective after this time.

**WARNING: THIS ALARM IS POWERED BY AN INTERNAL SEALED LITHIUM BATTERY AND CANNOT BE CONNECTED TO ANY OTHER POWER SOURCE.**

## TESTING

It is recommended that you test your alarm once a week to ensure the alarm is working correctly. Push and hold the test button for approximately 5 seconds. A loud pulsating alarm should sound and a **RED** indicator light (**LED**) will flash at the same time.

**WARNING:** Never use an open flame of any type to test your alarm.

**WARNING:** Do not apply excessive force on the "HUSH/TEST" button this may damage the smoke alarm and may void the warranty.

### Featured LED and Alarm Signal



#### Fire Warning Signal

The smoke alarm will sound a loud alarm (85 dB) and the red **LED** will flash rapidly. This will continue until the air is cleared



#### Standby

The red **LED** flashes once every 40-60 seconds to indicate the Cycle smoke alarm and battery are functioning correctly.



#### Memory Function

If one of the alarm indicators (**RED LED**) is flashing every 4 seconds, it indicates that a smoke alarm has previously been activated.



#### Low Battery

The smoke alarm indicates a low battery by flashing the red **LED** once and emitting a chirp every 40-60 seconds.

## HUSH OR SILENCE FUNCTION

- This fire alarm has a built-in Hush or Silence feature incorporated into the Test/Hush button. If cooking or other non-hazardous sources cause the alarm to sound, it can be temporarily silenced by pressing the Test/Hush button for 1 second. The alarm will then enter a dormant period for 10 minutes. After the 10 minute dormant period, the fire alarm will resume normal operation.

**Note:** After the Test/Hush button has been pressed, wait 10 minutes before any additional testing is conducted to avoid any abnormal responses as the smoke alarm is less sensitive to smoke during this period.

- This fire alarm has a self-diagnosis. If the alarm detects the battery is low and/or an internal fault, it will chirp. This alarm can be temporarily silenced by holding the Test/Hush button for 1 second. The alarm will not chirp for 10 hours but the alarm will continue to function. It is recommended to replace the alarm as soon as possible after this period of time.

**Note:** Silence will not affect the basic fire warning functions of a smoke alarm. During the silenced period, if the smoke alarm detects any smoke, it will still emit a fire signal

Fig.10



**WARNING: IF THERE IS ANY QUESTION AS TO THE CAUSE OF AN ALARM IT SHOULD BE ASSUMED THAT THE ALARM IS DUE TO AN ACTUAL FIRE AND THE DWELLING SHOULD BE EVACUATED IMMEDIATELY.**

## IMPORTANT SAFEGUARDS

Installation of your alarm is only one step in your safety plan. Other important steps should be taken to further improve your safety:

- Install the alarm properly, following this instruction leaflet
- Test your alarm weekly
- Do not smoke in bed
- Keep matches & lighters away from children
- Store flammable materials in a proper manner and never use them near naked flames or sparks
- Maintain emergency equipment such as fire extinguishers, escape ladders etc and ensure all occupants know how to use them correctly.
- Plan an escape route/s from your building in advance and ensure all occupants are aware of them. Re-enforce this awareness periodically throughout the year. See below planning:
- Create a floor plan that identifies all doors and windows, as well as at least two escape routes from each room. Note that for second-storey houses, rope or chainladders may be necessary.
- Hold a family meeting to discuss and review your escape plan, ensuring that each member understands what to do in case of a fire.
- Designate a predetermined location outside of your home where all family members can meet in the event of a fire.
- Ensure that everyone is familiar with the sound of the smoke alarm and conduct regular practice drills of leaving the home when it goes off.
- Conduct fire drills at least every six months, including night-time drills.
- Practicing your escape plan allows you to test its effectiveness before an actual emergency. It is crucial that every member of the household is aware of the plan, as they may need to act quickly and independently in the event of an emergency.

## IN CASE OF FIRE

Developing and practicing a plan of escape is essential for ensuring the safety of your household in the event of a fire. When the fire alarm sounds, it is crucial that you follow the steps outlined below:

- Evacuate the building immediately using your pre-determined escape plan. Time is crucial, so do not waste time getting dressed or retrieving valuables.
- While exiting, check the surface of internal doors before opening them. If the door feels hot or smoke is seeping through cracks, do not open it. Instead, use an alternative exit. If the door feels cool, gently open it, placing your shoulder against it, and be prepared to swiftly close it if heat or smoke rush in.
- If the air is smoky, stay close to the floor and try to breathe shallowly through a damp cloth if available.
- Once outside, proceed to your designated meeting point and ensure that all family members are present.
- Call the Fire and Rescue Services from a neighbour's home, not from your own.
- Do not re-enter your home until officials confirm that it is safe to do so. For additional information on fire safety, please contact your local Fire and Rescue Services.

## MAINTENANCE, REPAIRS AND SERVICE

To ensure your fire alarm is properly maintained, repaired, and serviced, it is crucial to follow the appropriate guidelines. Please review the information provided below:

### Maintenance:

To optimise performance, it is advised to conduct a monthly inspection of your alarm. Check for any accumulation of dirt, dust, or insects. You can use a vacuum cleaner or a soft brush to gently remove any debris. Additionally, wiping the alarm with a damp cloth will help deter insects. After cleaning, always test the fire alarm to confirm it is functioning correctly.

### Repairs / Servicing:

If you encounter a defective fire alarm, it is important not to attempt any repairs yourself. The unit does not contain parts that can be serviced by the user. Instead, it is recommended to seek professional assistance for replacement or servicing.

**Contact:** customerservices@hispec.co.uk for further advice.

### DISPOSAL

#### DO NOT ATTEMPT TO DISPOSE OF THE ALARM IN A FIRE

This Alarm should be disposed of at your local recycling centre, for further advice on safe disposal of Alarms contact your local authority.

## LIMITATION OF SMOKE ALARMS

It is important to note the limitations of smoke alarms and consider the following points:

- Smoke alarms can only detect smoke if it reaches the device. This means that fires originating in areas far away from the alarm, such as chimneys, walls, roofs, or other floors of the building, may not be detected.
- If the smoke alarm is located outside of the bedrooms or on a different floor, it may not wake up individuals who are deep sleepers. To enhance safety, it is recommended to install a smoke alarm in each bedroom for added protection.
- Although smoke alarms provide early warning of a fire and can save lives, they should not be seen as a substitute for having an insurance policy in place.
- Standard smoke alarms do not effectively alert individuals who have hearing impairments. For those with hearing impairments, it is advised to use specialised devices such as Red Strobe Lights and Vibrating Pads to ensure everyone in the building is alerted during a fire emergency.
- By being aware of these limitations, individuals can take proactive measures to optimise the effectiveness of their smoke alarms and prioritise their safety by taking appropriate precautions against the risks of fire.

### INDICATION AND ACTION

If you notice any signals from the fire alarm and you're unsure about its state, consult the provided table below for the "LED Indicator" and "sounder" of your heat alarm. This table will assist you in identifying the current status of the alarm and the necessary steps to take.

Should you need additional help, we suggest contacting our technical support for any inquiries. The contact details can be found in this manual.

STATUS	LED INDICATOR	SOUNDER	ACTION REQUIRED
Standby Mode	Red LED 1 flash every 40-60 sec	None	Fire alarm in standby condition, powered by internal sealed battery power.
Fire Alarm Mode	Red LED flashing rapidly until fire clear	Chirping rapidly until smoke is clear	Fire alarm detects fire. See section - "In case of fire"
Test Mode	Red LED flashing rapidly (flash pattern sync with the sounder)	Chirping rapidly (chirp pattern sync with the Red LED)	Release test button to cease test mode.
Low Battery Warning	Red LED 1 flash every 40-60 sec	1 short chirp every 40-60 seconds (Chirp pattern sync with the Red LED)	The battery is low. Check Section - "Maintenance, Repairs, and Service" for further details.
Memory Function	Red LED 1 flash every 4 seconds, lasting 72 hours	None	This indication will last for 72 hours. Then, it will automatically resume to standby mode. No action required.
Unit Fault	Red LED 2 short flashes every 40-60 seconds	2 short chirps every 40-60 seconds (Chirp pattern sync with the Red LED)	The alarm unit is faulty. Check Section - "Maintenance, Repairs, and Service" for further instruction.

## GUARANTEE

### WARNING: DO NOT ATTEMPT TO OPEN THE HOUSING.

This alarm is in guarantee under normal use and service for a period of 5 years (excluding battery) from date of purchase. The company will not be obligated to repair or replace parts which are found to be in need of repair because of misuse, damage or alterations present after the date of purchase. If the alarm is proven to be faulty, within the guarantee period, it must be returned to where it was purchased, carefully packaged, with the fault clearly stated along with proof of purchase. The liability of the company arising from the sale of this alarm shall not in any case exceed the cost of replacement of alarm and in no case shall the company be liable for consequential loss or damages resulting from the failure of the alarm.

HISPEC Electrical Products Ltd., Chorley, Lancs, England 25 Technical Documentation Held by Manufacturer	HISPEC Electrical Products Ltd., Chorley, Lancs, England 25 Technical Documentation Held by Manufacturer
<b>BS EN14604:2005 + AC:2008</b> <b>Smoke Alarm Devices: BD/BOH/10</b>	
<b>Fire Safety</b>	
Nominal activation conditions/ sensitivity, response delay (response time) and performance under fire condition	Vibration resistance <b>PASS</b>
Operational reliability	Humidity resistance <b>PASS</b>
Tolerance to voltage supply	Corrosion resistance <b>PASS</b>
Response delay and temperature resistance	Electrical stability <b>PASS</b>
<b>Heat Alarm Devices: BD/BOH/10</b>	<b>Heat Alarm Devices: BD/BOH/10</b>

HISPEC ELECTRICAL PRODUCTS LTD. SHALL HAVE NO LIABILITY FOR ANY PERSONAL INJURY OR PROPERTY DAMAGE, OR ANY SPECIAL INCIDENTAL, CONTINGENT OR CONSEQUENTIAL DAMAGE OF ANY KIND RESULTING FROM A FIRE. THE EXCLUSIVE REMEDY FOR BREACH OF THE LIMITED WARRANTY CONTAINED HEREIN IS THE REPAIR OR REPLACEMENT OF THE DETECTIVE PRODUCT AT HISPEC ELECTRICAL PRODUCTS LTD. IN NO CIRCUMSTANCES WITHOUT EXCEPTION, SHALL HISPEC ELECTRICAL PRODUCTS LTD.'S LIABILITY, UNDER ANY OTHER REMEDY PRESCRIBED OR OTHERWISE BY LAW, EXCEEDS THE PURCHASE PRICE OF THE INDIVIDUAL ALARM. YOUR ALARM IS NOT A SUBSTITUTE FOR PROPERTY, DISABILITY, LIFE OR OTHER INSURANCE OF ANY KIND. APPROPRIATE COVERAGE IS YOUR RESPONSIBILITY. CONSULT YOUR INSURANCE AGENT. "Black & Decker" and BLACK+DECKER™ and the Black & Decker® and BLACK+DECKER™ logos are registered trademarks of The Black & Decker Corporation and are used under licence by HISPEC Electrical Products Ltd. All rights reserved."

Waste electrical products should not be disposed of with normal household waste. Please recycle where facilities exist. Check with your Local Authority or retailer for recycling advice. New regulation will encourage the recycling of Waste from Electrical and Electronic Equipment (European "WEEE Directive" effective August 2005).



Information regarding substances of very high concern (SVHC) according to the Regulation 1907/2006/EC (REACH)

This product contains Lead element, CAS Number: 7439-92-1

**UK:** HISPEC Electrical Products Ltd, Unit 21, Drumhead Road, Chorley North Business Park, Chorley, PR6 7BX  
**T:** 01257 262 197

**EU:** HISPEC Electrical Products Ltd, Dublin, Ireland, D02 Y940

[www.blackanddecker.co.uk](http://www.blackanddecker.co.uk)

This does not affect your statutory rights. This alarm is only suitable for residential dwellings and is not suitable for commercial or industrial use.