

PRODUCT FEATURES:

- **Interconnectable:** Link with other fire alarms for full home protection
- **Mains Powered:** Reliable operation with no frequent battery changes
- **Replaceable Backup Battery:** Stays active during power outages
- **Fast Fix Base Included:** For quick and easy installation
- **Heat Detection:** The Thermistor sensor detects heat from fires
- **Test & Hush:** Simple testing and nuisance alarm control
- **Durable Build:** Long lasting, high quality, fire retardant ABS construction
- **Insect Proof:** Reduced False Alarms



DESCRIPTION:

The **Black + Decker Heat Alarm** is a complete mains powered unit. This alarm can interconnect with up to 20 units. This also comes with our Fast Fix base for easy installation. Installed with a 9V battery backup, this alarm also features a test button, a loud 85dB alarm, a low battery warning indicator and an advanced thermistor sensor.

TECHNICAL SPECIFICATION:

Ambient Operating Temperature:	0°C - 40°C
Power Consumption (In Alarm):	≤40mA
Power Consumption (Standby):	≤10µA
Ambient Operating Humidity:	0. to 90%
Power Source:	220-240v AC 50Hz
Housing Material:	Fire Retardant ABS
Electrical Class:	Class II
Min/Max Cable CSA:	0.75mm ² to 1.5mm ²
Backup Power Source:	9V Battery
Weight:	178g
Grade of Alarm:	D2
Alarm Sounder Level:	85dB at 3 metres
Approved To:	BS 5446-2:2003
Designed For Installation To:	BS 5839-6:2019
Max Interconnected Units:	20
Max Hardwire Interconnect Distance:	150m
Backup Battery Life (No Mains):	30 Days
Storage Temperature:	-10° to 50°
Storage Humidity:	0-90%RH (non-condensing)

**All information is subject to change and should be verified before any critical action.*



KITCHEN HEAT ALARM

MAINS POWERED WITH REPLACEABLE BATTERY BACKUP

LINE DRAWINGS:

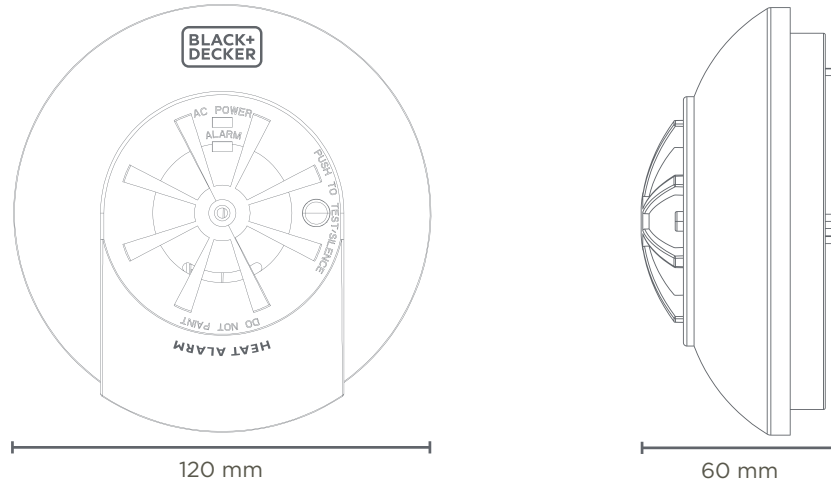

INSTALLATION LOCATIONS:



KM 792789
BS 5446-2:2003

**All information is subject to change and should be verified before any critical action.*

