

GOLBAL PROCUREMENT AND MARKETING LIMITED

TYLER DESK

Assembly instruction- Please keep for future reference

DESTYLGRY

BSD1001

BSD1002

BSD1003

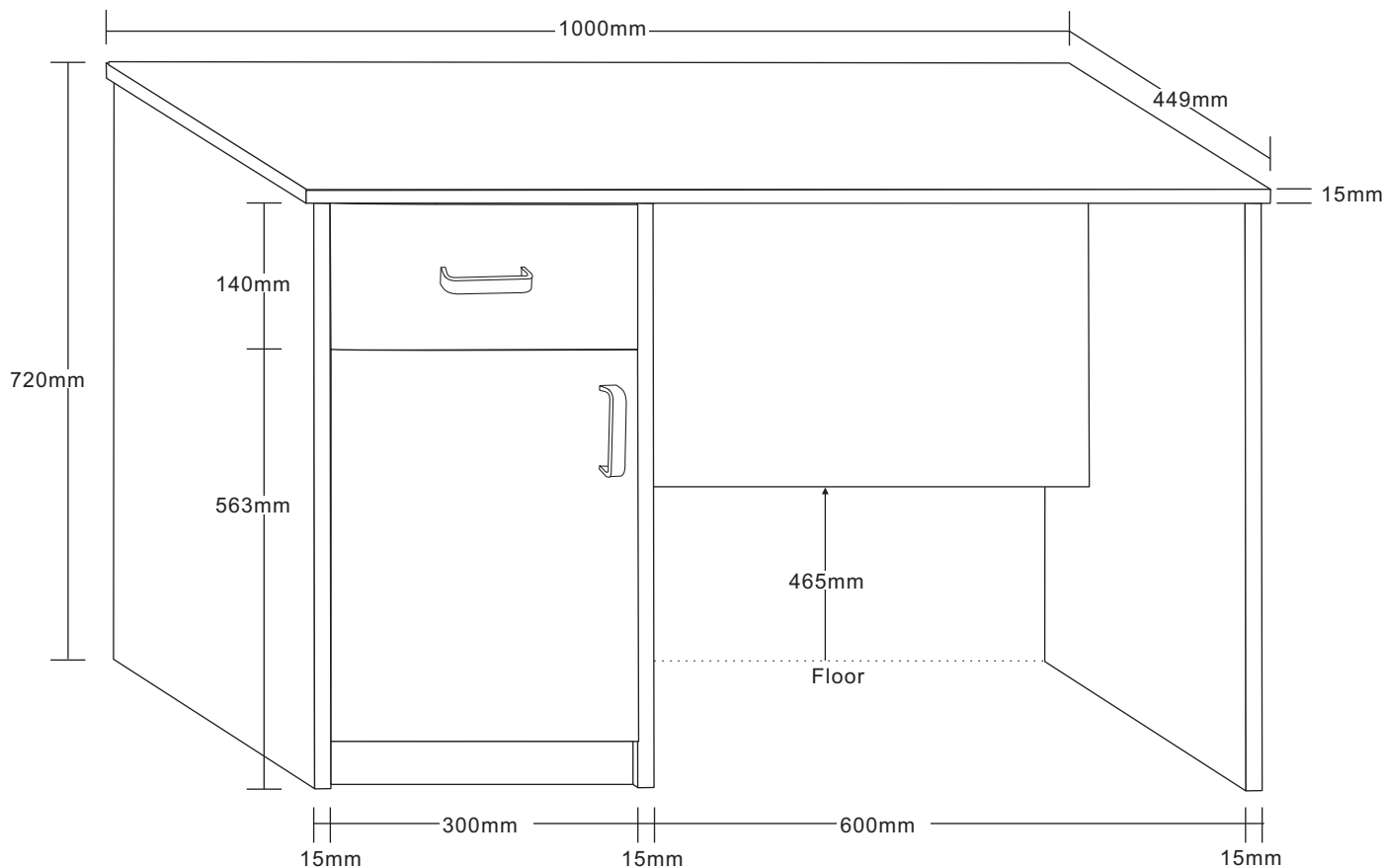

Dimensions	No. People	Assembly Time	OW#
Width: 100 cm Depth: 45 cm Height: 72 cm		90 mins (approx)	DESTYLGRY BSD1001 BSD1002 BSD1003

thank you

For purchasing this
GPM Limited
product

Important

- PLEASE READ THESE INSTRUCTION FULLY BEFORE STARTING ASSEMBLY.
- PLEASE DO NOT THROW THE PACKAGING AWAY UNTIL YOU ARE SATISFIED WITH PURCHASE, GOODS NEED TO BE RETURNED IN ORIGINAL PACKAGING.

If you need help or have damaged or missing parts, please email aftersales@gpmfurniture.co.uk

⚠ Safety and Care Advice

Important-Please read these instructions fully before starting assembly

- Check you have all the components and tools listed on pages 2,3 and 4.
- Remove all fittings from the plastic bags and separate them into their groups.
- Keep children and animals away from the work area, small parts could choke if swallowed.
- Make sure you have enough space to lay out the parts before starting.
- Do not stand or put weight on the product, this could cause damage.
- Assemble the item as close to its final position (in the same room) as possible.
- Assemble on a soft, level surface to avoid damaging the unit or your floor.
- We do not recommend the use of power drill/drivers for inserting screw, as this could damage the unit. only use hand screwdrivers.
- Dispose of all packaging carefully and responsibly.



Care and Maintenance

- Only clean using a damp cloth and mild detergent, do not use bleach or abrasive cleaners.
- From time to time check that there are no loose screws on this unit.
- This product should not be discarded with household waste. Take to your local authority waste disposal centre.

If you are unhappy with the product and wish to return it, please following the retailer's returns procedure.

Components - Panels

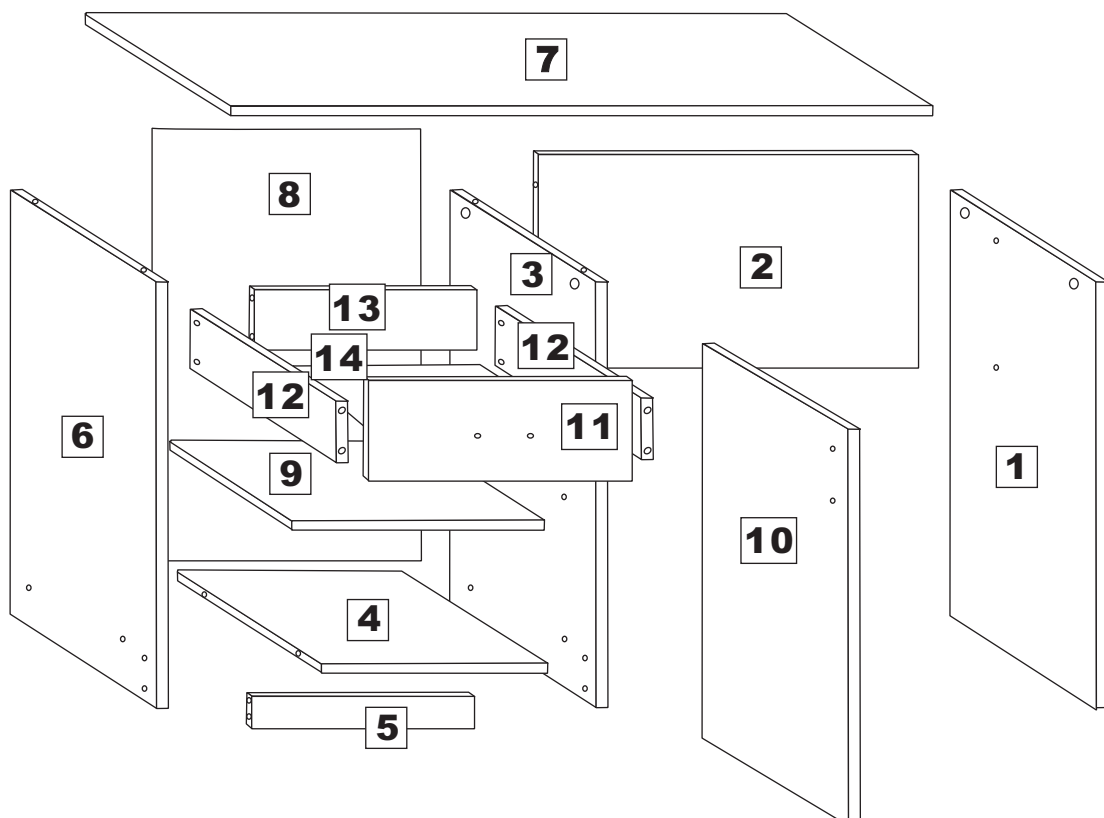











Components - Fixings

If you have damaged or missing components,
email: aftersales@gpmfurniture.co.uk

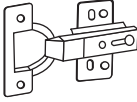
Please check that you have all the components listed below before constructing your item.

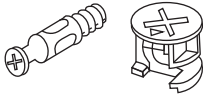
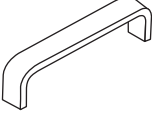
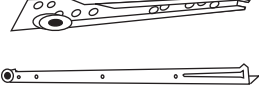
Note: The quantities below are the correct amount to complete the assembly. In some cases more fittings may be supplied than are required.

<p>(A)</p>  <p>JCBC M6 X 40mm X 10</p>	<p>(B)</p>  <p>M4 X 32mm X 4</p>	<p>(C)</p>  <p>M3.5 X 14mm X 24</p>	<p>(D)</p>  <p>Button Head 18mm X 4</p>
<p>(E)</p>  <p>Nail X 20</p>	<p>(F)</p>  <p>Metal Shelf Support X 5</p>	<p>(G)</p>  <p>Hinges X 2</p>	<p>(H)</p>  <p>Dowel (M8X25) X 2</p>
<p>(I)</p>  <p>Leg Pin X 6</p>	<p>(J)</p>  <p>Bolt Nut MiniFit set X 8</p>	<p>(K)</p>  <p>Handle X 2</p>	<p>(L)</p>  <p>Drawer Slide 14" X 1 set</p>
<p>(M)</p>  <p>Allen Key X 1</p>			

Tools Required (Not Provided)



Ruler - Use this to measure your screws (mm)

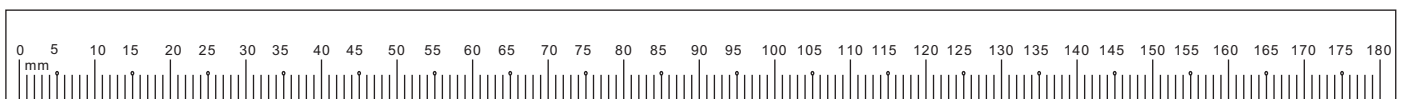

Important-Please read these instructions fully before starting assembly

If you need help or have damaged or missing parts, please email aftersales@gpmfurniture.co.uk

Assembly Instructions

If you have damaged or missing components,
email: aftersales@gpmfurniture.co.uk

Step 1

Attach drawer slide rail **L** to Panel boards **3** & **6** with screw **C** using a screw driver onto the specific pre-drilled pilot holes as shown below.

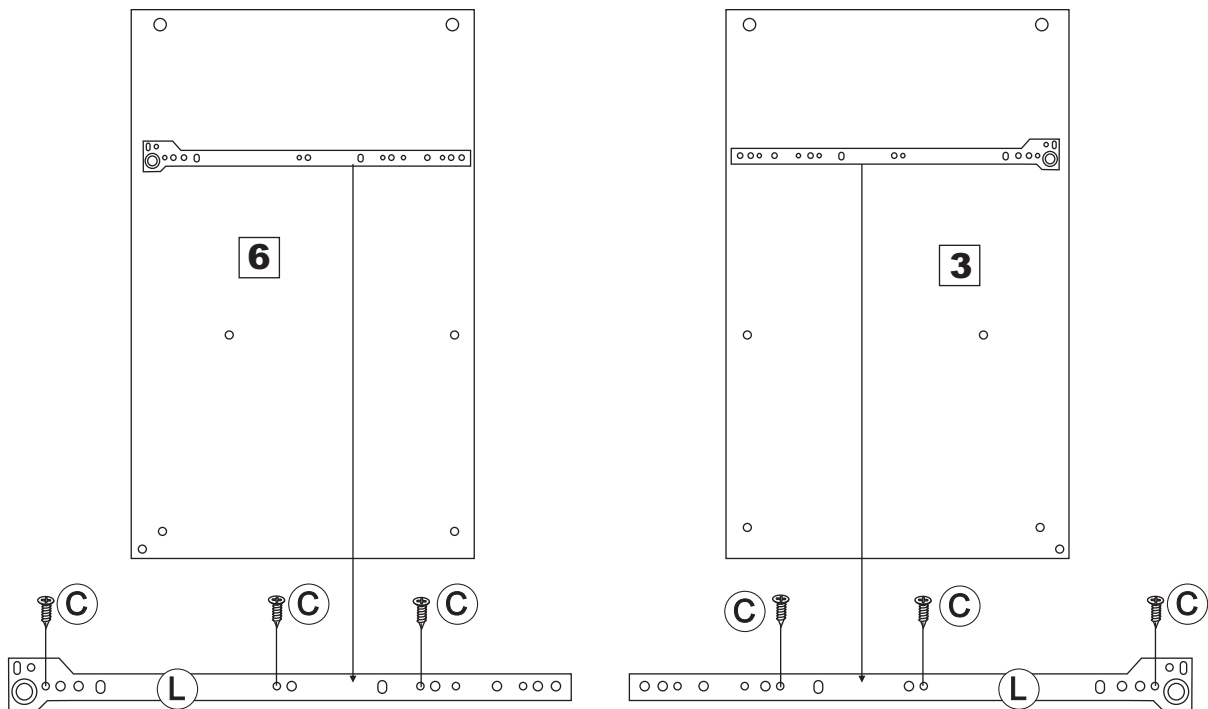

Step 2a

Step 2

Attach Minifit Nut **J** into the pre-drilled holes on panel **1**, **3**, **6** & **7**.

Attach Minifit Bolt **J** using screw driver to panel **7**

Attach Shelf support **F** using a small hammer into the predrilled holes on Panel **3** & **6** as shown.

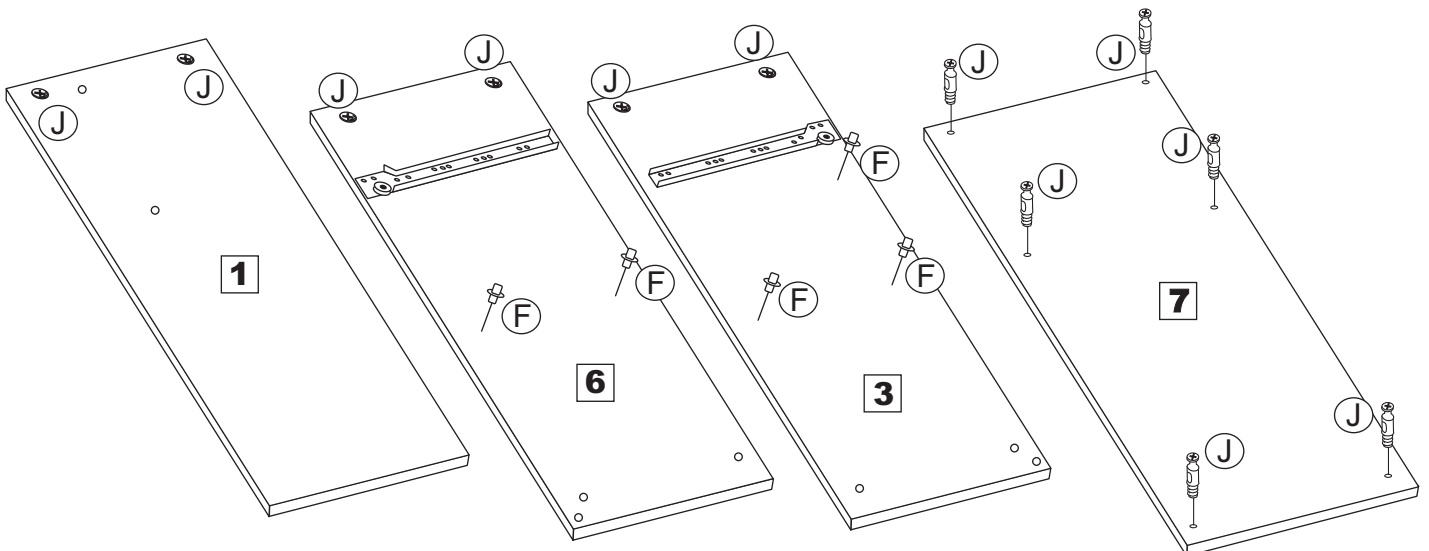

Step 2b

Attach minifit bolt **J** using a screw driver to Drawer front panel **11**

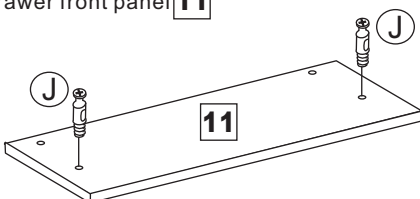

Step 2c

Attach Dowel **H** and Minifit Nut **J** to Drawer side panel **12**, as shown.

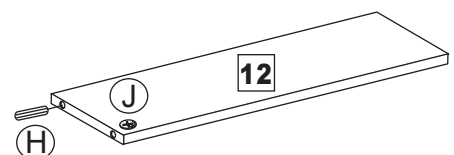

Step 3

Step 3a

Attach Handle (K) to drawer front panel (11) with (D) bolt using a screw driver.

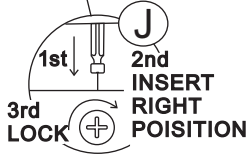
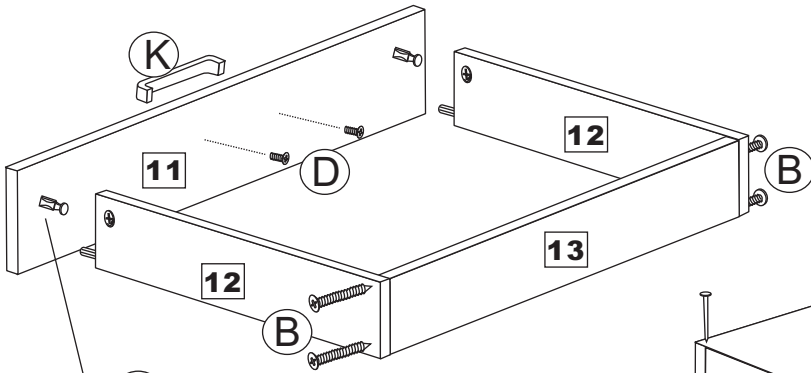

Step 3b

Secure the Side panel (12) to Front panel (11) with minifit as shown
Secure the drawer back panel (13) with Screw (B) using a screw driver.

Step 3c

Attach base board (14) with nail (E) to the drawer base using a small hammer.

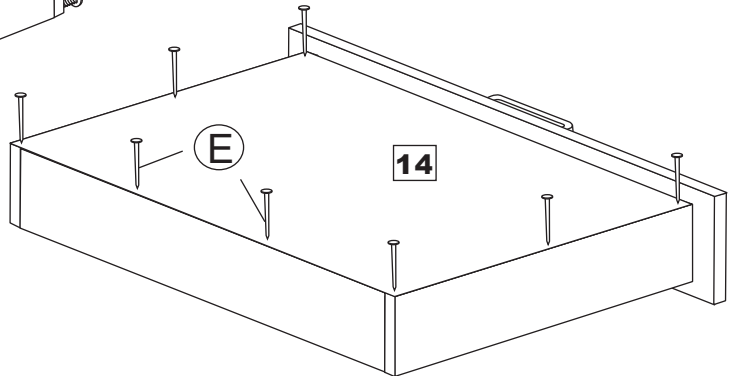

Step 4

Attach drawer slide rail (L) to drawer base with screw (C) and tighten with screw driver.

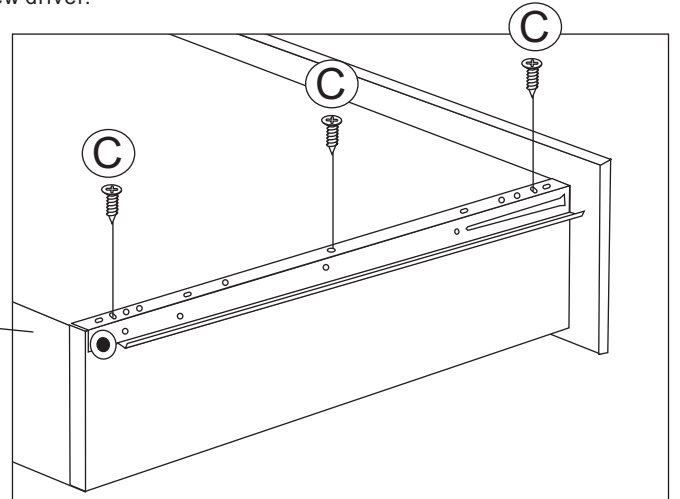
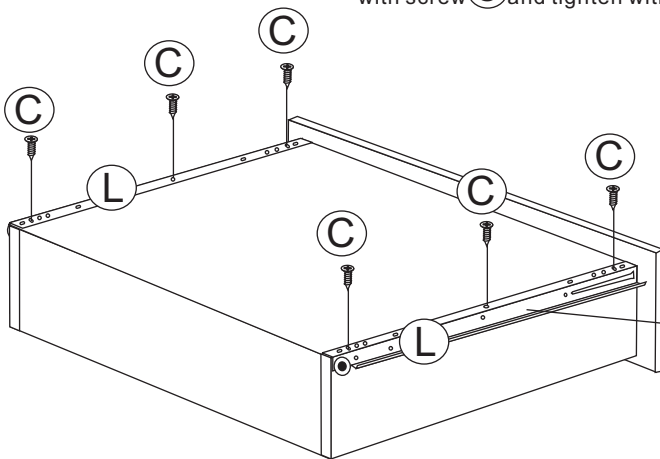

Step 5

Attach Panel (1), (2) & (3) with Screw (A) using Allen key to tighten.

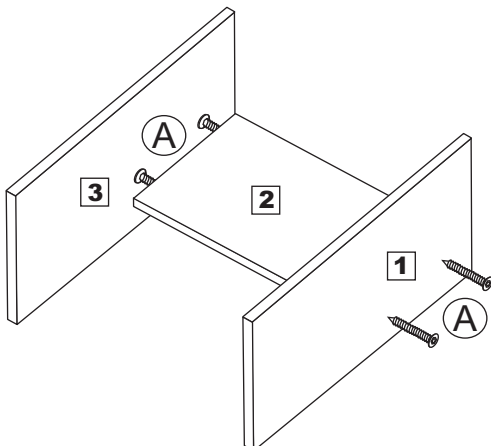

Step 6

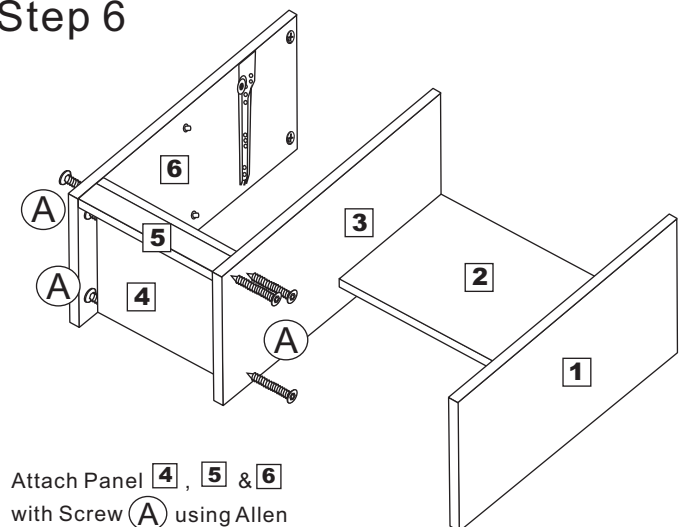

Attach Panel (4), (5) & (6) with Screw (A) using Allen key to tighten.

Step 7

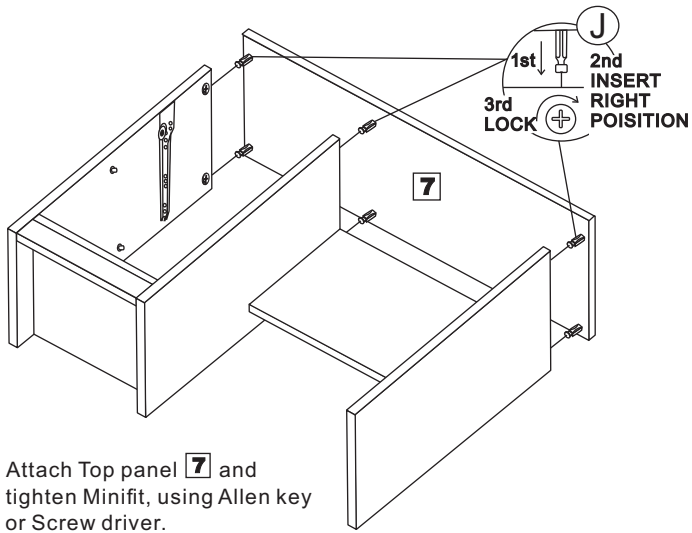

Attach Top panel **7** and tighten Minifit, using Allen key or Screw driver.

Step 8

Step 8a Attach Back Panel **8** with Nail **E** using a hammer.

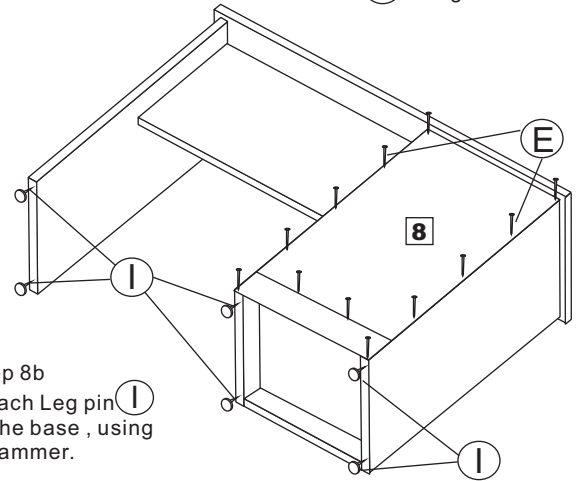

Step 8b Attach Leg pin **I** to the base, using a hammer.

Step 9

Step 9a Install Hinges **G** with Screw **C** and tighten using a Screw driver.

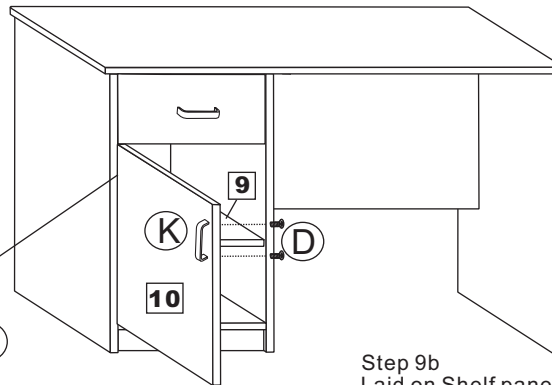
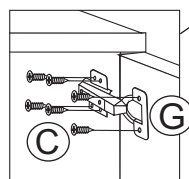

Step 9b Laid on Shelf panel **9**

Step 9c Attach Handle **K** to door panel **10** with Bolt **D** using a Screw driver.

Assembly Complete

